

A
EC
C
D
E
F
G
H
I
J
K
L
M
N
O
P

SECTION **EC**

ENGINE CONTROL SYSTEM

CONTENTS

VQ37VHR

<p>BASIC INSPECTION 9</p> <p>DIAGNOSIS AND REPAIR WORKFLOW 9</p> <p style="padding-left: 20px;">Work Flow9</p> <p style="padding-left: 20px;">Diagnostic Work Sheet 12</p> <p>INSPECTION AND ADJUSTMENT13</p> <p>BASIC INSPECTION13</p> <p style="padding-left: 20px;">BASIC INSPECTION : Special Repair Requirement 13</p> <p>ADDITIONAL SERVICE WHEN REPLACING CONTROL UNIT (ECM) 16</p> <p style="padding-left: 20px;">ADDITIONAL SERVICE WHEN REPLACING CONTROL UNIT (ECM) : Description 16</p> <p style="padding-left: 20px;">ADDITIONAL SERVICE WHEN REPLACING CONTROL UNIT (ECM) : Special Repair Requirement 16</p> <p>ADDITIONAL SERVICE WHEN REPLACING CONTROL UNIT (VVEL CONTROL MODULE) 17</p> <p style="padding-left: 20px;">ADDITIONAL SERVICE WHEN REPLACING CONTROL UNIT (VVEL CONTROL MODULE) : Description 17</p> <p style="padding-left: 20px;">ADDITIONAL SERVICE WHEN REPLACING CONTROL UNIT (VVEL CONTROL MODULE) : Special Repair Requirement 17</p> <p>IDLE SPEED17</p> <p style="padding-left: 20px;">IDLE SPEED : Description 17</p> <p style="padding-left: 20px;">IDLE SPEED : Special Repair Requirement 17</p> <p>IGNITION TIMING 17</p> <p style="padding-left: 20px;">IGNITION TIMING : Description 17</p> <p style="padding-left: 20px;">IGNITION TIMING : Special Repair Requirement... 17</p> <p>VIN REGISTRATION 18</p> <p style="padding-left: 20px;">VIN REGISTRATION : Description 18</p> <p style="padding-left: 20px;">VIN REGISTRATION : Special Repair Requirement 18</p>	<p>ACCELERATOR PEDAL RELEASED POSITION LEARNING18</p> <p style="padding-left: 20px;">ACCELERATOR PEDAL RELEASED POSITION LEARNING : Description18</p> <p style="padding-left: 20px;">ACCELERATOR PEDAL RELEASED POSITION LEARNING : Special Repair Requirement18</p> <p>THROTTLE VALVE CLOSED POSITION LEARNING18</p> <p style="padding-left: 20px;">THROTTLE VALVE CLOSED POSITION LEARNING : Description18</p> <p style="padding-left: 20px;">THROTTLE VALVE CLOSED POSITION LEARNING : Special Repair Requirement18</p> <p>IDLE AIR VOLUME LEARNING19</p> <p style="padding-left: 20px;">IDLE AIR VOLUME LEARNING : Description19</p> <p style="padding-left: 20px;">IDLE AIR VOLUME LEARNING : Special Repair Requirement19</p> <p>VVEL CONTROL SHAFT POSITION SENSOR ADJUSTMENT20</p> <p style="padding-left: 20px;">VVEL CONTROL SHAFT POSITION SENSOR ADJUSTMENT : Description21</p> <p style="padding-left: 20px;">VVEL CONTROL SHAFT POSITION SENSOR ADJUSTMENT : Special Repair Requirement21</p> <p>MIXTURE RATIO SELF-LEARNING VALUE CLEAR22</p> <p style="padding-left: 20px;">MIXTURE RATIO SELF-LEARNING VALUE CLEAR : Description22</p> <p style="padding-left: 20px;">MIXTURE RATIO SELF-LEARNING VALUE CLEAR : Special Repair Requirement22</p> <p>SYSTEM DESCRIPTION24</p> <p>ENGINE CONTROL SYSTEM24</p> <p style="padding-left: 20px;">System Diagram24</p> <p style="padding-left: 20px;">System Description25</p> <p style="padding-left: 20px;">Component Parts Location25</p> <p style="padding-left: 20px;">Component Description32</p> <p>MULTIPOINT FUEL INJECTION SYSTEM34</p>
---	---

System Diagram	34	Component Function Check	132
System Description	34	Diagnosis Procedure	133
Component Parts Location	37	POWER SUPPLY AND GROUND CIRCUIT ...	140
Component Description	43	Diagnosis Procedure	140
ELECTRIC IGNITION SYSTEM	45	POWER SUPPLY AND GROUND CIRCUIT	
System Diagram	45	(VVEL CONTROL MODULE)	143
System Description	45	Diagnosis Procedure	143
Component Parts Location	46	U0101 CAN COMM CIRCUIT	145
Component Description	52	Description	145
AIR CONDITIONING CUT CONTROL	54	DTC Logic	145
System Diagram	54	Diagnosis Procedure	145
System Description	54	U0113, U1003 CAN COMM CIRCUIT	146
Component Parts Location	55	Description	146
Component Description	61	DTC Logic	146
AUTOMATIC SPEED CONTROL DEVICE		Diagnosis Procedure	146
(ASCD)	62	U0164 CAN COMM CIRCUIT	148
System Diagram	62	Description	148
System Description	62	DTC Logic	148
Component Parts Location	64	Diagnosis Procedure	148
Component Description	70	U1001 CAN COMM CIRCUIT	149
CAN COMMUNICATION	71	Description	149
System Description	71	DTC Logic	149
COOLING FAN CONTROL	72	Diagnosis Procedure	149
System Diagram	72	U1024 CAN COMM CIRCUIT	150
System Description	72	Description	150
Component Parts Location	73	DTC Logic	150
Component Description	79	Diagnosis Procedure	150
EVAPORATIVE EMISSION SYSTEM	80	P0011, P0021 IVT CONTROL	152
System Diagram	80	DTC Logic	152
System Description	80	Diagnosis Procedure	153
Component Parts Location	83	Component Inspection	154
Component Description	89	P0031, P0032, P0051, P0052 A/F SENSOR 1	
INTAKE VALVE TIMING CONTROL	91	HEATER	156
System Diagram	91	Description	156
System Description	91	DTC Logic	156
Component Parts Location	92	Diagnosis Procedure	157
Component Description	98	Component Inspection	158
VVEL SYSTEM	99	P0037, P0038, P0057, P0058 HO2S2 HEAT-	
System Diagram	99	ER	159
System Description	99	Description	159
Component Parts Location	100	DTC Logic	159
Component Description	106	Diagnosis Procedure	160
ON BOARD DIAGNOSTIC (OBD) SYSTEM ..	107	Component Inspection	161
Diagnosis Description	107	P0075, P0081 IVT CONTROL SOLENOID	
CONSULT-III Function	120	VALVE	162
Diagnosis Tool Function	129	Description	162
DTC/CIRCUIT DIAGNOSIS	132	DTC Logic	162
TROUBLE DIAGNOSIS - SPECIFICATION		Diagnosis Procedure	162
VALUE	132	Component Inspection	163
Description	132		

P0101, P010B MAF SENSOR	165	P0130, P0150 A/F SENSOR 1	201	A
Description	165	Description	201	
DTC Logic	165	DTC Logic	201	
Component Function Check	167	Component Function Check	203	
Diagnosis Procedure	167	Diagnosis Procedure	203	EC
Component Inspection	169			
P0102, P0103, P010C, P010D MAF SENSOR	172	P0131, P0151 A/F SENSOR 1	205	
Description	172	Description	205	C
DTC Logic	172	DTC Logic	205	
Diagnosis Procedure	173	Diagnosis Procedure	206	
Component Inspection	174			
P010A MANIFOLD ABSOLUTE PRESSURE SENSOR	178	P0132, P0152 A/F SENSOR 1	208	D
Description	178	Description	208	
DTC Logic	178	DTC Logic	208	E
Diagnosis Procedure	178	Diagnosis Procedure	209	
Component Inspection	179	P0133, P0153 A/F SENSOR 1	211	F
P0112, P0113 IAT SENSOR	182	Description	211	
Description	182	DTC Logic	211	
DTC Logic	182	Diagnosis Procedure	213	
Diagnosis Procedure	183	P0137, P0157 HO2S2	216	G
Component Inspection	183	Description	216	
P0116 ECT SENSOR	185	DTC Logic	216	H
Description	185	Component Function Check	217	
DTC Logic	185	Diagnosis Procedure	218	
Diagnosis Procedure	186	Component Inspection	220	
Component Inspection	186	P0138, P0158 HO2S2	222	I
P0117, P0118 ECT SENSOR	187	Description	222	
Description	187	DTC Logic	222	J
DTC Logic	187	Component Function Check	224	
Diagnosis Procedure	188	Diagnosis Procedure	225	
Component Inspection	188	Component Inspection	227	
P0122, P0123, P0227, P0228 TP SENSOR	190	P0139, P0159 HO2S2	230	K
Description	190	Description	230	
DTC Logic	190	DTC Logic	230	L
Diagnosis Procedure	191	Component Function Check	231	
Component Inspection	192	Diagnosis Procedure	232	
Special Repair Requirement	192	Component Inspection	234	
P0125 ECT SENSOR	194	P0171, P0174 FUEL INJECTION SYSTEM FUNCTION	236	M
Description	194	DTC Logic	236	
DTC Logic	194	Diagnosis Procedure	237	N
Diagnosis Procedure	195	P0172, P0175 FUEL INJECTION SYSTEM FUNCTION	240	O
Component Inspection	195	DTC Logic	240	
P0127 IAT SENSOR	197	Diagnosis Procedure	241	
Description	197	P0181 FTT SENSOR	244	P
DTC Logic	197	Description	244	
Diagnosis Procedure	198	DTC Logic	244	
Component Inspection	198	Diagnosis Procedure	245	
P0128 THERMOSTAT FUNCTION	199	Component Inspection	246	
DTC Logic	199	P0182, P0183 FTT SENSOR	247	
Diagnosis Procedure	199	Description	247	
Component Inspection	200	DTC Logic	247	

Diagnosis Procedure	247	P0443 EVAP CANISTER PURGE VOLUME CONTROL SOLENOID VALVE	293
Component Inspection	249	Description	293
P0196 EOT SENSOR	250	DTC Logic	293
Description	250	Diagnosis Procedure	294
DTC Logic	250	Component Inspection	296
Diagnosis Procedure	251	P0444, P0445 EVAP CANISTER PURGE VOLUME CONTROL SOLENOID VALVE	298
Component Inspection	252	Description	298
P0197, P0198 EOT SENSOR	253	DTC Logic	298
Description	253	Diagnosis Procedure	298
DTC Logic	253	Component Inspection	300
Diagnosis Procedure	254	P0447 EVAP CANISTER VENT CONTROL VALVE	301
Component Inspection	254	Description	301
P0222, P0223, P2132, P2133 TP SENSOR ...	256	DTC Logic	301
Description	256	Diagnosis Procedure	301
DTC Logic	256	Component Inspection	303
Diagnosis Procedure	257	P0448 EVAP CANISTER VENT CONTROL VALVE	305
Component Inspection	258	Description	305
Special Repair Requirement	258	DTC Logic	305
P0300, P0301, P0302, P0303, P0304, P0305, P0306 MISFIRE	260	Diagnosis Procedure	306
DTC Logic	260	Component Inspection	307
Diagnosis Procedure	261	P0451 EVAP CONTROL SYSTEM PRESSURE SENSOR	309
P0327, P0328, P0332, P0333 KS	266	Description	309
Description	266	DTC Logic	309
DTC Logic	266	Diagnosis Procedure	309
Diagnosis Procedure	266	Component Inspection	311
Component Inspection	267	P0452 EVAP CONTROL SYSTEM PRESSURE SENSOR	312
P0335 CKP SENSOR (POS)	269	Description	312
Description	269	DTC Logic	312
DTC Logic	269	Diagnosis Procedure	313
Diagnosis Procedure	270	Component Inspection	315
Component Inspection	272	P0453 EVAP CONTROL SYSTEM PRESSURE SENSOR	317
P0340, P0345 CMP SENSOR (PHASE)	273	Description	317
Description	273	DTC Logic	317
DTC Logic	273	Diagnosis Procedure	318
Diagnosis Procedure	274	Component Inspection	321
Component Inspection	275	P0455 EVAP CONTROL SYSTEM	323
P0420, P0430 THREE WAY CATALYST FUNCTION	277	DTC Logic	323
DTC Logic	277	Diagnosis Procedure	325
Component Function Check	278	Component Inspection	327
Diagnosis Procedure	279	P0456 EVAP CONTROL SYSTEM	329
P0441 EVAP CONTROL SYSTEM	282	DTC Logic	329
DTC Logic	282	Component Function Check	331
Component Function Check	283	Diagnosis Procedure	331
Diagnosis Procedure	284	Component Inspection	335
P0442 EVAP CONTROL SYSTEM	287		
DTC Logic	287		
Diagnosis Procedure	288		
Component Inspection	292		

P0460 FUEL LEVEL SENSOR	336	Description	363	A
Description	336	DTC Logic	363	
DTC Logic	336	Diagnosis Procedure	363	
Diagnosis Procedure	336			
P0461 FUEL LEVEL SENSOR	338	P0643 SENSOR POWER SUPPLY	364	EC
Description	338	DTC Logic	364	
DTC Logic	338	Diagnosis Procedure	364	
Component Function Check	338			
Diagnosis Procedure	339	P0850 PNP SWITCH	367	C
		Description	367	
P0462, P0463 FUEL LEVEL SENSOR	340	DTC Logic	367	
Description	340	Component Function Check	368	D
DTC Logic	340	Diagnosis Procedure	368	
Diagnosis Procedure	340			
P0500 VSS	342	P100A, P100B VVEL SYSTEM	371	E
Description	342	DTC Logic	371	
DTC Logic	342	Diagnosis Procedure	371	
Component Function Check	343	Component Inspection (VVEL ACTUATOR MO-		F
Diagnosis Procedure	343	TOR)	373	
		Component Inspection (VVEL ACTUATOR SUB		
P0506 ISC SYSTEM	344	ASSEMBLY)	373	
Description	344	Special Repair Requirement	374	G
DTC Logic	344			
Diagnosis Procedure	344	P1087, P1088 VVEL SYSTEM	375	H
		DTC Logic	375	
P0507 ISC SYSTEM	346			
Description	346	P1089, P1092 VVEL CONTROL SHAFT PO-		
DTC Logic	346	SITION SENSOR	376	I
Diagnosis Procedure	346	Description	376	
		DTC Logic	376	
P0524 ENGINE OIL PRESSURE	348	Diagnosis Procedure	376	
DTC Logic	348	Special Repair Requirement	378	J
Diagnosis Procedure	349			
Component Inspection	350	P1090, P1093 VVEL ACTUATOR MOTOR	380	K
		Description	380	
P0550 PSP SENSOR	351	DTC Logic	380	
Description	351	Diagnosis Procedure	380	
DTC Logic	351	Component Inspection (VVEL ACTUATOR MO-		L
Diagnosis Procedure	351	TOR)	382	
Component Inspection	352	Component Inspection (VVEL ACTUATOR SUB		
		ASSEMBLY)	382	
P0555 BRAKE BOOSTER PRESSURE SEN-		Special Repair Requirement	383	M
SOR	354			
Description	354	P1091 VVEL ACTUATOR MOTOR RELAY ...	384	N
DTC Logic	354	Description	384	
Diagnosis Procedure	354	DTC Logic	384	
Component Inspection	357	Diagnosis Procedure	384	
		Component Inspection	386	
P0603 ECM POWER SUPPLY	359			O
Description	359	P1148, P1168 CLOSED LOOP CONTROL	387	
DTC Logic	359	DTC Logic	387	
Diagnosis Procedure	359			
P0605 ECM	361	P1211 TCS CONTROL UNIT	388	P
Description	361	Description	388	
DTC Logic	361	DTC Logic	388	
Diagnosis Procedure	362	Diagnosis Procedure	388	
P0607 ECM	363			
		P1212 TCS COMMUNICATION LINE	389	
		Description	389	
		DTC Logic	389	
		Diagnosis Procedure	389	

P1217 ENGINE OVER TEMPERATURE	390	Diagnosis Procedure	414
DTC Logic	390	Component Inspection	416
Component Function Check	390		
Diagnosis Procedure	391		
P1225, P1234 TP SENSOR	394	P1551, P1552 BATTERY CURRENT SEN-	SOR
Description	394	Description	417
DTC Logic	394	DTC Logic	417
Diagnosis Procedure	394	Diagnosis Procedure	417
Special Repair Requirement	395	Component Inspection	419
P1226, P1235 TP SENSOR	396	P1553 BATTERY CURRENT SENSOR	420
Description	396	Description	420
DTC Logic	396	DTC Logic	420
Diagnosis Procedure	396	Diagnosis Procedure	420
Special Repair Requirement	397	Component Inspection	422
P1233, P2101 ELECTRIC THROTTLE CON-		P1554 BATTERY CURRENT SENSOR	423
TROL FUNCTION	398	Description	423
Description	398	DTC Logic	423
DTC Logic	398	Component Function Check	423
Diagnosis Procedure	398	Diagnosis Procedure	424
Component Inspection	401	Component Inspection	425
Special Repair Requirement	401	P1564 ASCD STEERING SWITCH	427
P1236, P2118 THROTTLE CONTROL MO-		Description	427
TOR	402	DTC Logic	427
Description	402	Diagnosis Procedure	427
DTC Logic	402	Component Inspection	429
Diagnosis Procedure	402	P1564 ICC STEERING SWITCH	430
Component Inspection	403	Description	430
Special Repair Requirement	404	DTC Logic	430
P1238, P2119 ELECTRIC THROTTLE CON-		Diagnosis Procedure	430
TROL ACTUATOR	405	Component Inspection	432
Description	405	P1568 ICC FUNCTION	433
DTC Logic	405	DTC Logic	433
Diagnosis Procedure	406	Diagnosis Procedure	433
Special Repair Requirement	406	P1572 ASCD BRAKE SWITCH	434
P1239, P2135 TP SENSOR	407	Description	434
Description	407	DTC Logic	434
DTC Logic	407	Diagnosis Procedure	435
Diagnosis Procedure	407	Component Inspection (ASCD Brake Switch)	439
Component Inspection	409	Component Inspection (ASCD Clutch Switch)	440
Special Repair Requirement	409	Component Inspection (Stop Lamp Switch)	440
P1290, P2100, P2103 THROTTLE CONTROL		P1572 ICC BRAKE SWITCH	441
MOTOR RELAY	410	Description	441
Description	410	DTC Logic	441
DTC Logic	410	Diagnosis Procedure	442
Diagnosis Procedure	410	Component Inspection (ICC Brake Switch)	446
P1421 COLD START CONTROL	412	Component Inspection (ICC Clutch Switch)	447
Description	412	Component Inspection (Stop Lamp Switch)	447
DTC Logic	412	Component Inspection (ICC Brake Hold Relay) ..	448
Diagnosis Procedure	412	P1574 ASCD VEHICLE SPEED SENSOR	449
P1550 BATTERY CURRENT SENSOR	414	Description	449
Description	414	DTC Logic	449
DTC Logic	414	Diagnosis Procedure	449

P1574 ICC VEHICLE SPEED SENSOR	451	Component Function Check	485	A
Description	451	Diagnosis Procedure	485	
DTC Logic	451			
Diagnosis Procedure	451			
P1606 VVEL CONTROL MODULE	453	COOLING FAN	486	EC
Description	453	Description	486	
DTC Logic	453	Component Function Check	486	
Diagnosis Procedure	453	Diagnosis Procedure	486	
		Component Inspection (Cooling Fan Motor)	488	C
		Component Inspection (Cooling Fan Relay)	489	
P1607 VVEL CONTROL MODULE	455	ELECTRICAL LOAD SIGNAL	490	D
Description	455	Description	490	
DTC Logic	455	Component Function Check	490	
Diagnosis Procedure	455	Diagnosis Procedure	490	
P1608 VVEL SENSOR POWER SUPPLY	457	FUEL INJECTOR	492	E
DTC Logic	457	Description	492	
Diagnosis Procedure	457	Component Function Check	492	
Special Repair Requirement	458	Diagnosis Procedure	492	F
		Component Inspection	494	
P1805 BRAKE SWITCH	460	FUEL PUMP	495	G
Description	460	Description	495	
DTC Logic	460	Component Function Check	495	
Diagnosis Procedure	460	Diagnosis Procedure	495	
Component Inspection (Stop Lamp Switch)	461	Component Inspection	497	H
P2122, P2123 APP SENSOR	463	ICC BRAKE SWITCH	498	I
Description	463	Description	498	
DTC Logic	463	Component Function Check	498	
Diagnosis Procedure	463	Diagnosis Procedure	498	
Component Inspection	465	Component Inspection (ICC Brake Switch)	501	J
Special Repair Requirement	465	Component Inspection (ICC Clutch Switch)	501	
P2127, P2128 APP SENSOR	467	IGNITION SIGNAL	503	K
Description	467	Description	503	
DTC Logic	467	Component Function Check	503	
Diagnosis Procedure	468	Diagnosis Procedure	503	
Component Inspection	470	Component Inspection (Ignition Coil with Power Transistor)	506	L
Special Repair Requirement	470	Component Inspection (Condenser)	507	
P2138 APP SENSOR	471	MALFUNCTION INDICATOR LAMP	508	M
Description	471	Description	508	
DTC Logic	471	Component Function Check	508	
Diagnosis Procedure	472	Diagnosis Procedure	508	
Component Inspection	474			
Special Repair Requirement	475	ON BOARD REFUELING VAPOR RECOVERY (ORVR)	509	O
P2A00, P2A03 A/F SENSOR 1	476	Description	509	
Description	476	Component Function Check	509	
DTC Logic	476	Diagnosis Procedure	509	
Diagnosis Procedure	477	Component Inspection	512	P
ASCD BRAKE SWITCH	480	POSITIVE CRANKCASE VENTILATION	514	
Description	480	Description	514	
Component Function Check	480	Component Inspection	514	
Diagnosis Procedure	480			
Component Inspection (ASCD Brake Switch)	483	REFRIGERANT PRESSURE SENSOR	516	
Component Inspection (ASCD Clutch Switch)	483	Description	516	
ASCD INDICATOR	485	Component Function Check	516	
Description	485			

Diagnosis Procedure	516	On Board Diagnostic (OBD) System of Engine and A/T	601
ECU DIAGNOSIS INFORMATION	518	General Precautions	601
ECM	518	PREPARATION	605
Reference Value	518	PREPARATION	605
Wiring Diagram - ENGINE CONTROL SYSTEM ..	534	Special Service Tools	605
Fail safe	553	Commercial Service Tools	605
DTC Inspection Priority Chart	555	PERIODIC MAINTENANCE	607
DTC Index	557	FUEL PRESSURE	607
How to Set SRT Code	561	Inspection	607
Test Value and Test Limit	564	EVAP LEAK CHECK	608
VVEL CONTROL MODULE	571	Inspection	608
Reference Value	571	REMOVAL AND INSTALLATION	610
Wiring Diagram - ENGINE CONTROL SYSTEM ..	575	EVAP CANISTER	610
SYMPTOM DIAGNOSIS	595	Exploded View	610
ENGINE CONTROL SYSTEM SYMPTOMS ..	595	Removal and Installation	610
Symptom Table	595	Inspection	611
NORMAL OPERATING CONDITION	599	SERVICE DATA AND SPECIFICATIONS (SDS)	612
Description	599	SERVICE DATA AND SPECIFICATIONS (SDS)	612
PRECAUTION	600	Idle Speed	612
PRECAUTIONS	600	Ignition Timing	612
Precaution for Supplemental Restraint System (SRS) "AIR BAG" and "SEAT BELT PRE-TEN- SIONER"	600	Calculated Load Value	612
Precaution for Procedure without Cowl Top Cover.	600	Mass Air Flow Sensor	612
Precautions For Xenon Headlamp Service	600		

DIAGNOSIS AND REPAIR WORKFLOW

< BASIC INSPECTION >

[VQ37VHR]

BASIC INSPECTION

DIAGNOSIS AND REPAIR WORKFLOW

Work Flow

INFOID:000000005151619

OVERALL SEQUENCE

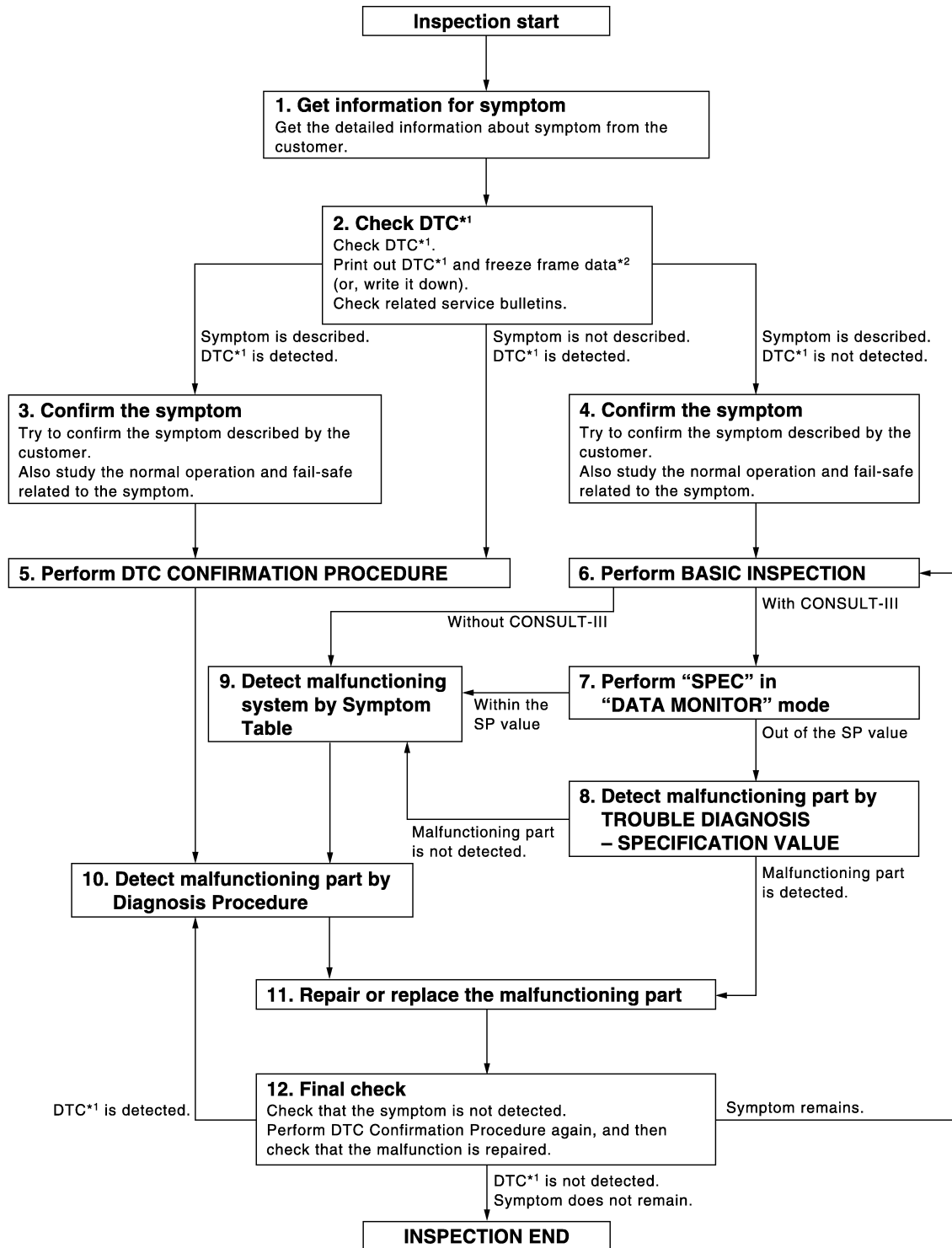

*1: Include 1st trip DTC.

*2: Include 1st trip freeze frame data.

JMBIA1416GB

DETAILED FLOW

DIAGNOSIS AND REPAIR WORKFLOW

[VQ37VHR]

< BASIC INSPECTION >

1. GET INFORMATION FOR SYMPTOM

Get the detailed information from the customer about the symptom (the condition and the environment when the incident/malfunction occurred) using the "Diagnostic Work Sheet". (Refer to [EC-12, "Diagnostic Work Sheet"](#).)

>> GO TO 2.

2. CHECK DTC

1. Check DTC.
2. Perform the following procedure if DTC is displayed.
 - Record DTC and freeze frame data. (Print them out with CONSULT-III or GST.)
 - Erase DTC. (Refer to [EC-107, "Diagnosis Description"](#).)
 - Study the relationship between the cause detected by DTC and the symptom described by the customer. (Symptom Table is useful. Refer to [EC-595, "Symptom Table"](#).)
3. Check related service bulletins for information.

Are any symptoms described and any DTCs detected?

Symptom is described, DTC is detected>>GO TO 3.

Symptom is described, DTC is not detected>>GO TO 4.

Symptom is not described, DTC is detected>>GO TO 5.

3. CONFIRM THE SYMPTOM

Try to confirm the symptom described by the customer (except MIL ON).

Also study the normal operation and fail-safe related to the symptom. Refer to [EC-599, "Description"](#) and [EC-553, "Fail safe"](#).

Diagnosis Work Sheet is useful to verify the incident.

Verify relation between the symptom and the condition when the symptom is detected.

>> GO TO 5.

4. CONFIRM THE SYMPTOM

Try to confirm the symptom described by the customer.

Also study the normal operation and fail-safe related to the symptom. Refer to [EC-599, "Description"](#) and [EC-553, "Fail safe"](#).

Diagnosis Work Sheet is useful to verify the incident.

Verify relation between the symptom and the condition when the symptom is detected.

>> GO TO 6.

5. PERFORM DTC CONFIRMATION PROCEDURE

Perform DTC CONFIRMATION PROCEDURE for the displayed DTC, and then make sure that DTC is detected again.

If two or more DTCs are detected, refer to [EC-555, "DTC Inspection Priority Chart"](#) and determine trouble diagnosis order.

NOTE:

- Freeze frame data is useful if the DTC is not detected.
- Perform Component Function Check if DTC CONFIRMATION PROCEDURE is not included on Service Manual. This simplified check procedure is an effective alternative though DTC cannot be detected during this check.
 - If the result of Component Function Check is NG, it is the same as the detection of DTC by DTC CONFIRMATION PROCEDURE.

Is DTC detected?

YES >> GO TO 10.

NO >> Check according to [GI-36, "Intermittent Incident"](#).

6. PERFORM BASIC INSPECTION

Perform [EC-13, "BASIC INSPECTION : Special Repair Requirement"](#).

Do you have CONSULT-III?

DIAGNOSIS AND REPAIR WORKFLOW

[VQ37VHR]

< BASIC INSPECTION >

- YES >> GO TO 7.
- NO >> GO TO 9.

7. PERFORM SPEC IN DATA MONITOR MODE

With CONSULT-III

Make sure that "MAS A/F SE-B1", "MAS A/F SE-B2", "B/FUEL SCHDL", "A/F ALPHA-B1" and "A/F ALPHA-B2" are within the SP value using CONSULT-III "SPEC" in "DATA MONITOR" mode. Refer to [EC-132. "Component Function Check"](#).

Is the measurement value within the SP value?

- YES >> GO TO 9.
- NO >> GO TO 8.

8. DETECT MALFUNCTIONING PART BY TROUBLE DIAGNOSIS - SPECIFICATION VALUE

Detect malfunctioning part according to [EC-133. "Diagnosis Procedure"](#).

Is a malfunctioning part detected?

- YES >> GO TO 11.
- NO >> GO TO 9.

9. DETECT MALFUNCTIONING SYSTEM BY SYMPTOM TABLE

Detect malfunctioning system according to [EC-595. "Symptom Table"](#) based on the confirmed symptom in step 4, and determine the trouble diagnosis order based on possible causes and symptoms.

>> GO TO 10.

10. DETECT MALFUNCTIONING PART BY DIAGNOSIS PROCEDURE

Inspect according to Diagnosis Procedure of the system.

NOTE:

The Diagnosis Procedure in EC section described based on open circuit inspection. A short circuit inspection is also required for the circuit check in the Diagnosis Procedure. For details, refer to [GI-39. "Circuit Inspection"](#).

Is a malfunctioning part detected?

- YES >> GO TO 11.
- NO >> Monitor input data from related sensors or check voltage of related ECM terminals using CONSULT-III. Refer to [EC-518. "Reference Value"](#).

11. REPAIR OR REPLACE THE MALFUNCTIONING PART

1. Repair or replace the malfunctioning part.
2. Reconnect parts or connectors disconnected during Diagnosis Procedure again after repair and replacement.
3. Check DTC. If DTC is displayed, erase it. Refer to [EC-107. "Diagnosis Description"](#).

>> GO TO 12.

12. FINAL CHECK

When DTC was detected in step 2, perform DTC CONFIRMATION PROCEDURE or Component Function Check again, and then make sure that the malfunction have been completely repaired.

When symptom was described from the customer, refer to confirmed symptom in step 3 or 4, and make sure that the symptom is not detected.

Is DTC detected and does symptom remain?

- YES-1 >> DTC is detected: GO TO 10.
- YES-2 >> Symptom remains: GO TO 6.
- NO >> Before returning the vehicle to the customer, always erase unnecessary DTC in ECM and TCM (Transmission Control Module). (Refer to [EC-107. "Diagnosis Description"](#).) If the completion of SRT is needed, drive vehicle under the specific driving pattern. Refer to [EC-561. "How to Set SRT Code"](#).

DIAGNOSIS AND REPAIR WORKFLOW

< BASIC INSPECTION >

[VQ37VHR]

Diagnostic Work Sheet

INFOID:000000005151620

DESCRIPTION

There are many operating conditions that lead to the malfunction of engine components. A good grasp of such conditions can make troubleshooting faster and more accurate.

In general, each customer feels differently about an incident. It is important to fully understand the symptoms or conditions for a customer complaint.

Utilize a diagnostic worksheet like the WORKSHEET SAMPLE below in order to organize all the information for troubleshooting.

Some conditions may cause the MIL to illuminate steady or blink and DTC to be detected. Examples:

- Vehicle ran out of fuel, which caused the engine to misfire.
- Fuel filler cap was left off or incorrectly screwed on, allowing fuel to evaporate into the atmosphere.

KEY POINTS

- WHAT** Vehicle & engine model
WHEN Date, Frequencies
WHERE..... Road conditions
HOW Operating conditions,
 Weather conditions,
 Symptoms

SEF907L

WORKSHEET SAMPLE

Customer name MR/MS		Model & Year	VIN
Engine #		Trans.	Mileage
Incident Date		Manuf. Date	In Service Date
Fuel and fuel filler cap		<input type="checkbox"/> Vehicle ran out of fuel causing misfire <input type="checkbox"/> Fuel filler cap was left off or incorrectly screwed on.	
Symptoms	<input type="checkbox"/> Startability	<input type="checkbox"/> Impossible to start <input type="checkbox"/> No combustion <input type="checkbox"/> Partial combustion <input type="checkbox"/> Partial combustion affected by throttle position <input type="checkbox"/> Partial combustion NOT affected by throttle position <input type="checkbox"/> Possible but hard to start <input type="checkbox"/> Others []	
	<input type="checkbox"/> Idling	<input type="checkbox"/> No fast idle <input type="checkbox"/> Unstable <input type="checkbox"/> High idle <input type="checkbox"/> Low idle <input type="checkbox"/> Others []	
	<input type="checkbox"/> Driveability	<input type="checkbox"/> Stumble <input type="checkbox"/> Surge <input type="checkbox"/> Knock <input type="checkbox"/> Lack of power <input type="checkbox"/> Intake backfire <input type="checkbox"/> Exhaust backfire <input type="checkbox"/> Others []	
	<input type="checkbox"/> Engine stall	<input type="checkbox"/> At the time of start <input type="checkbox"/> While idling <input type="checkbox"/> While accelerating <input type="checkbox"/> While decelerating <input type="checkbox"/> Just after stopping <input type="checkbox"/> While loading	
Incident occurrence		<input type="checkbox"/> Just after delivery <input type="checkbox"/> Recently <input type="checkbox"/> In the morning <input type="checkbox"/> At night <input type="checkbox"/> In the daytime	
Frequency		<input type="checkbox"/> All the time <input type="checkbox"/> Under certain conditions <input type="checkbox"/> Sometimes	
Weather conditions		<input type="checkbox"/> Not affected	
	Weather	<input type="checkbox"/> Fine <input type="checkbox"/> Raining <input type="checkbox"/> Snowing <input type="checkbox"/> Others []	
	Temperature	<input type="checkbox"/> Hot <input type="checkbox"/> Warm <input type="checkbox"/> Cool <input type="checkbox"/> Cold <input type="checkbox"/> Humid °F	
Engine conditions		<input type="checkbox"/> Cold <input type="checkbox"/> During warm-up <input type="checkbox"/> After warm-up Engine speed _____ <div style="display: flex; justify-content: space-between; width: 200px; margin: 0 auto;"> 0 2,000 4,000 6,000 8,000 rpm </div>	
Road conditions		<input type="checkbox"/> In town <input type="checkbox"/> In suburbs <input type="checkbox"/> Highway <input type="checkbox"/> Off road (up/down)	
Driving conditions		<input type="checkbox"/> Not affected <input type="checkbox"/> At starting <input type="checkbox"/> While idling <input type="checkbox"/> At racing <input type="checkbox"/> While accelerating <input type="checkbox"/> While cruising <input type="checkbox"/> While decelerating <input type="checkbox"/> While turning (RH/LH) Vehicle speed _____ <div style="display: flex; justify-content: space-between; width: 200px; margin: 0 auto;"> 0 10 20 30 40 50 60 MPH </div>	
Malfunction indicator lamp		<input type="checkbox"/> Turned on <input type="checkbox"/> Not turned on	

MTBL0017

INSPECTION AND ADJUSTMENT

BASIC INSPECTION

BASIC INSPECTION : Special Repair Requirement

INFOID:000000005151621

A

EC

1.INSPECTION START

1. Check service records for any recent repairs that may indicate a related malfunction, or a current need for scheduled maintenance.
2. Open engine hood and check the following:
 - Harness connectors for improper connections
 - Wiring harness for improper connections, pinches and cut
 - Vacuum hoses for splits, kinks and improper connections
 - Hoses and ducts for leaks
 - Air cleaner clogging
 - Gasket
3. Confirm that electrical or mechanical loads are not applied.
 - Headlamp switch is OFF.
 - Air conditioner switch is OFF.
 - Rear window defogger switch is OFF.
 - Steering wheel is in the straight-ahead position, etc.
4. Start engine and warm it up until engine coolant temperature indicator points the middle of gauge.
Ensure engine stays below 1,000 rpm.

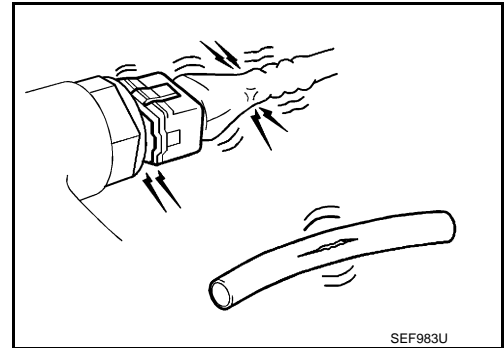

C

D

E

F

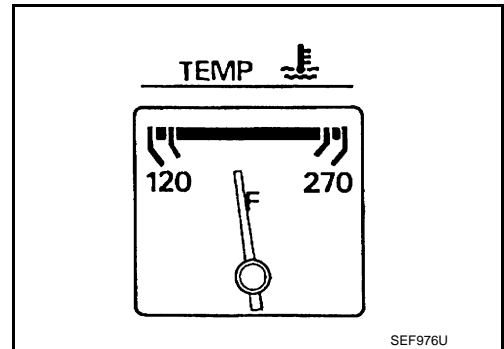

G

H

I

J

5. Run engine at about 2,000 rpm for about 2 minutes under no load.
6. Make sure that no DTC is displayed with CONSULT-III or GST.

Are any DTCs detected?

YES >> GO TO 2.

NO >> GO TO 3.

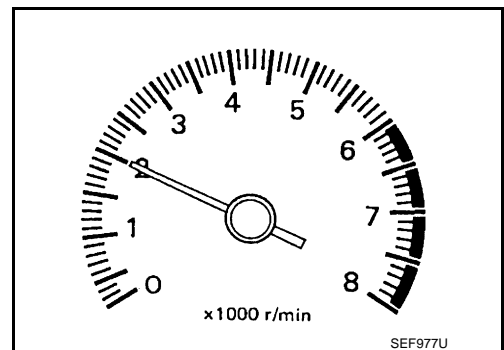

K

L

M

2.REPAIR OR REPLACE

Repair or replace components as necessary according to corresponding Diagnosis Procedure.

>> GO TO 3

3.CHECK IDLE SPEED

1. Run engine at about 2,000 rpm for about 2 minutes under no load.

N

O

P

INSPECTION AND ADJUSTMENT

[VQ37VHR]

< BASIC INSPECTION >

- Rev engine (2,000 to 3,000 rpm) two or three times under no load, then run engine at idle speed for about 1 minute.
- Check idle speed.
For procedure, refer to [EC-17, "IDLE SPEED : Special Repair Requirement"](#).
For specification, refer to [EC-612, "Idle Speed"](#).

Is the inspection result normal?

- YES >> GO TO 10.
NO >> GO TO 4.

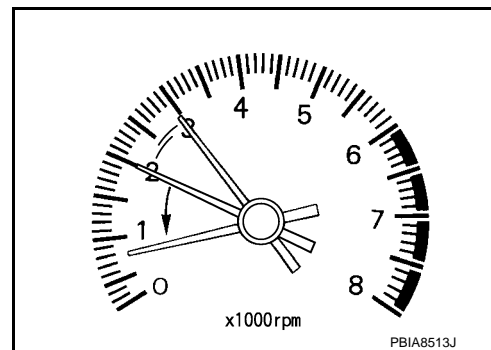

4.PERFORM ACCELERATOR PEDAL RELEASED POSITION LEARNING

- Stop engine.
- Perform [EC-18, "ACCELERATOR PEDAL RELEASED POSITION LEARNING : Special Repair Requirement"](#).

>> GO TO 5.

5.PERFORM THROTTLE VALVE CLOSED POSITION LEARNING

Perform [EC-18, "THROTTLE VALVE CLOSED POSITION LEARNING : Special Repair Requirement"](#).

>> GO TO 6.

6.PERFORM IDLE AIR VOLUME LEARNING

Perform [EC-19, "IDLE AIR VOLUME LEARNING : Special Repair Requirement"](#).

Is Idle Air Volume Learning carried out successfully?

- YES >> GO TO 7.
NO >> Follow the instruction of Idle Air Volume Learning. Then GO TO 4.

7.CHECK IDLE SPEED AGAIN

- Start engine and warm it up to normal operating temperature.
- Check idle speed.
For procedure, refer to [EC-17, "IDLE SPEED : Special Repair Requirement"](#).
For specification, refer to [EC-612, "Idle Speed"](#).

Is the inspection result normal?

- YES >> GO TO 10.
NO >> GO TO 8.

8.DETECT MALFUNCTIONING PART

Check the Following.

- Check camshaft position sensor (PHASE) and circuit. Refer to [EC-275, "Component Inspection"](#).
- Check crankshaft position sensor (POS) and circuit. Refer to [EC-272, "Component Inspection"](#).

Is the inspection result normal?

- YES >> GO TO 9.
NO >> Repair or replace. Then GO TO 4.

9.CHECK ECM FUNCTION

- Substitute with a non-malfunctioning ECM to check ECM function. (ECM may be the cause of the incident, although this is rare.)
- Perform initialization of IVIS (NATS) system and registration of all IVIS (NATS) ignition key IDs. Refer to [EC-16, "ADDITIONAL SERVICE WHEN REPLACING CONTROL UNIT \(ECM\) : Special Repair Requirement"](#).

>> GO TO 4.

10.CHECK IGNITION TIMING

- Run engine at idle.

INSPECTION AND ADJUSTMENT

[VQ37VHR]

< BASIC INSPECTION >

2. Check ignition timing with a timing light.

A :Timing indicator

For procedure, refer to [EC-17, "IGNITION TIMING : Special Repair Requirement"](#).

For specification, refer to [EC-612, "Ignition Timing"](#).

Is the inspection result normal?

- YES >> GO TO 19.
NO >> GO TO 11.

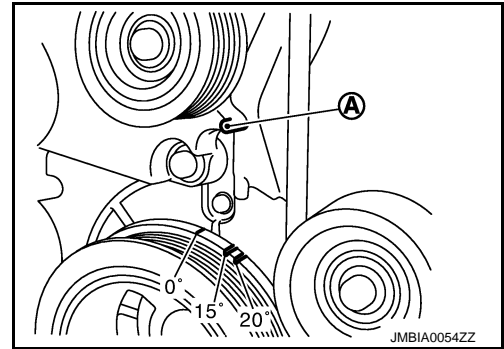

11.PERFORM ACCELERATOR PEDAL RELEASED POSITION LEARNING

1. Stop engine.
2. Perform [EC-18, "ACCELERATOR PEDAL RELEASED POSITION LEARNING : Special Repair Requirement"](#).

>> GO TO 12.

12.PERFORM THROTTLE VALVE CLOSED POSITION LEARNING

Perform [EC-18, "THROTTLE VALVE CLOSED POSITION LEARNING : Special Repair Requirement"](#).

>> GO TO 13.

13.PERFORM IDLE AIR VOLUME LEARNING

Perform [EC-19, "IDLE AIR VOLUME LEARNING : Special Repair Requirement"](#).

Is Idle Air Volume Learning carried out successfully?

- YES >> GO TO 14.
NO >> Follow the instruction of Idle Air Volume Learning. Then GO TO 4.

14.CHECK IDLE SPEED AGAIN

1. Start engine and warm it up to normal operating temperature.
2. Check idle speed.
For procedure, refer to [EC-17, "IDLE SPEED : Special Repair Requirement"](#).
For specification, refer to [EC-612, "Idle Speed"](#).

Is the inspection result normal?

- YES >> GO TO 15.
NO >> GO TO 17.

15.CHECK IGNITION TIMING AGAIN

1. Run engine at idle.
2. Check ignition timing with a timing light.

A :Timing indicator

For procedure, refer to [EC-17, "IGNITION TIMING : Special Repair Requirement"](#).

For specification, refer to [EC-612, "Ignition Timing"](#).

Is the inspection result normal?

- YES >> GO TO 19.
NO >> GO TO 16.

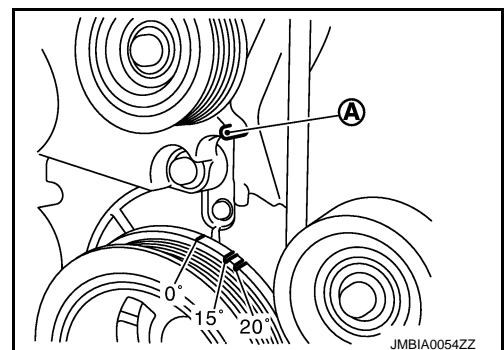

16.CHECK TIMING CHAIN INSTALLATION

Check timing chain installation. Refer to [EM-50, "Removal and Installation"](#).

Is the inspection result normal?

- YES >> GO TO 17.
NO >> Repair the timing chain installation. Then GO TO 4.

INSPECTION AND ADJUSTMENT

[VQ37VHR]

< BASIC INSPECTION >

17. DETECT MALFUNCTIONING PART

Check the following.

- Check camshaft position sensor (PHASE) and circuit. Refer to [EC-275, "Component Inspection"](#).
- Check crankshaft position sensor (POS) and circuit. Refer to [EC-272, "Component Inspection"](#).

Is the inspection result normal?

YES >> GO TO 18.

NO >> Repair or replace. Then GO TO 4.

18. CHECK ECM FUNCTION

1. Substitute with a non-malfunctioning ECM to check ECM function. (ECM may be the cause of the incident, although this is rare.)
2. Perform initialization of IVIS (NATS) system and registration of all IVIS (NATS) ignition key IDs. Refer to [SEC-8, "ECM RE-COMMUNICATING FUNCTION : Special Repair Requirement"](#).

>> GO TO 4.

19. INSPECTION END

If ECM is replaced during this BASIC INSPECTION procedure, go to [EC-16, "ADDITIONAL SERVICE WHEN REPLACING CONTROL UNIT \(ECM\) : Special Repair Requirement"](#).

>> INSPECTION END

ADDITIONAL SERVICE WHEN REPLACING CONTROL UNIT (ECM)

ADDITIONAL SERVICE WHEN REPLACING CONTROL UNIT (ECM) : Description

INFOID:000000005151622

When replacing ECM, the following procedure must be performed.

ADDITIONAL SERVICE WHEN REPLACING CONTROL UNIT (ECM) : Special Repair Requirement

INFOID:000000005151623

1. PERFORM INITIALIZATION OF IVIS (NATS) SYSTEM AND REGISTRATION OF ALL IVIS (NATS) IGNITION KEY IDS

Refer to [SEC-8, "ECM RE-COMMUNICATING FUNCTION : Special Repair Requirement"](#).

>> GO TO 2.

2. PERFORM VIN REGISTRATION

Refer to [EC-18, "VIN REGISTRATION : Special Repair Requirement"](#).

>> GO TO 3.

3. PERFORM ACCELERATOR PEDAL RELEASED POSITION LEARNING

Refer to [EC-18, "ACCELERATOR PEDAL RELEASED POSITION LEARNING : Special Repair Requirement"](#).

>> GO TO 4.

4. PERFORM THROTTLE VALVE CLOSED POSITION LEARNING

Refer to [EC-18, "THROTTLE VALVE CLOSED POSITION LEARNING : Special Repair Requirement"](#).

>> GO TO 5.

5. PERFORM IDLE AIR VOLUME LEARNING

Refer to [EC-19, "IDLE AIR VOLUME LEARNING : Special Repair Requirement"](#).

INSPECTION AND ADJUSTMENT

< BASIC INSPECTION >

[VQ37VHR]

>> END

ADDITIONAL SERVICE WHEN REPLACING CONTROL UNIT (VVEL CONTROL MODULE)

ADDITIONAL SERVICE WHEN REPLACING CONTROL UNIT (VVEL CONTROL MODULE) : Description

INFOID:000000005151624

When replacing VVEL control module, the following procedure must be performed.

ADDITIONAL SERVICE WHEN REPLACING CONTROL UNIT (VVEL CONTROL MODULE) : Special Repair Requirement

INFOID:000000005151625

1.PERFORM IDLE AIR VOLUME LEARNING

Refer to [EC-19. "IDLE AIR VOLUME LEARNING : Special Repair Requirement"](#).

>> END

IDLE SPEED

IDLE SPEED : Description

INFOID:000000005151626

This describes how to check the idle speed. For the actual procedure, follow the instructions in "BASIC INSPECTION".

IDLE SPEED : Special Repair Requirement

INFOID:000000005151627

1.CHECK IDLE SPEED

With CONSULT-III

Check idle speed in "DATA MONITOR" mode with CONSULT-III.

With GST

Check idle speed with Service \$01 of GST.

>> INSPECTION END

IGNITION TIMING

IGNITION TIMING : Description

INFOID:000000005151628

This describes how to check the ignition timing. For the actual procedure, follow the instructions in "BASIC INSPECTION".

IGNITION TIMING : Special Repair Requirement

INFOID:000000005151629

1.CHECK IGNITION TIMING

1. Attach timing light to loop wire as shown.

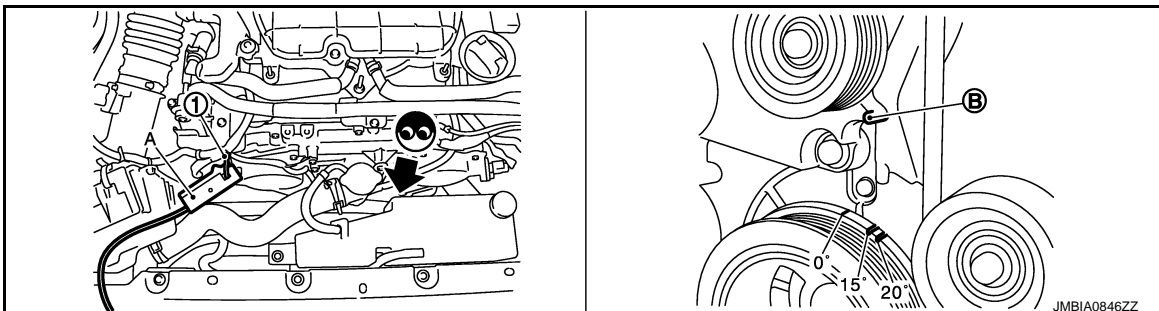

1. Loop wire

A. Timing light

B. Timing indicator

< BASIC INSPECTION >

2. Check ignition timing.

>> INSPECTION END

VIN REGISTRATION

VIN REGISTRATION : Description

INFOID:000000005151630

VIN Registration is an operation to registering VIN in ECM. It must be performed each time ECM is replaced.

NOTE:

Accurate VIN which is registered in ECM may be required for Inspection & Maintenance (I/M).

VIN REGISTRATION : Special Repair Requirement

INFOID:000000005151631

1. CHECK VIN

Check the VIN of the vehicle and note it. Refer to [GI-18. "Information About Identification or Model Code"](#).

>> GO TO 2.

2. PERFORM VIN REGISTRATION

 **With CONSULT-III**

1. Turn ignition switch ON and engine stopped.
2. Select "VIN REGISTRATION" in "WORK SUPPORT" mode.
3. Follow the instruction of CONSULT-III display.

>> END

ACCELERATOR PEDAL RELEASED POSITION LEARNING

ACCELERATOR PEDAL RELEASED POSITION LEARNING : Description

INFOID:000000005151632

Accelerator Pedal Released Position Learning is a function of ECM to learn the fully released position of the accelerator pedal by monitoring the accelerator pedal position sensor output signal. It must be performed each time the harness connector of the accelerator pedal position sensor or ECM is disconnected.

ACCELERATOR PEDAL RELEASED POSITION LEARNING : Special Repair Requirement

INFOID:000000005151633

1. START

1. Make sure that accelerator pedal is fully released.
2. Turn ignition switch ON and wait at least 2 seconds.
3. Turn ignition switch OFF and wait at least 10 seconds.
4. Turn ignition switch ON and wait at least 2 seconds.
5. Turn ignition switch OFF and wait at least 10 seconds.

>> END

THROTTLE VALVE CLOSED POSITION LEARNING

THROTTLE VALVE CLOSED POSITION LEARNING : Description

INFOID:000000005151634

Throttle Valve Closed Position Learning is a function of ECM to learn the fully closed position of the throttle valve by monitoring the throttle position sensor output signal. It must be performed each time harness connector of electric throttle control actuator or ECM is disconnected.

THROTTLE VALVE CLOSED POSITION LEARNING : Special Repair Requirement

INFOID:000000005151635

1. START

1. Make sure that accelerator pedal is fully released.

< BASIC INSPECTION >

2. Turn ignition switch ON.
3. Turn ignition switch OFF and wait at least 10 seconds.
Make sure that throttle valve moves during above 10 seconds by confirming the operating sound.

>> END

IDLE AIR VOLUME LEARNING

IDLE AIR VOLUME LEARNING : Description

INFOID:000000005151636

Idle Air Volume Learning is a function of ECM to learn the idle air volume that keeps engine idle speed within the specific range. It must be performed under the following conditions:

- Each time electric throttle control actuator or ECM is replaced.
- Each time VVEL actuator sub assembly or VVEL control module is replaced.
- Idle speed or ignition timing is out of specification.

IDLE AIR VOLUME LEARNING : Special Repair Requirement

INFOID:000000005151637

1. PRECONDITIONING

Make sure that all of the following conditions are satisfied.

Learning will be cancelled if any of the following conditions are missed for even a moment.

- Battery voltage: More than 12.9 V (At idle)
- Engine coolant temperature: 70 - 105°C (158 - 221°F)
- PNP switch: ON
- Electric load switch: OFF
(Air conditioner, headlamp, rear window defogger)
On vehicles equipped with daytime light systems, if the parking brake is applied before the engine is started the headlamp will not be illuminated.
- Steering wheel: Neutral (Straight-ahead position)
- Vehicle speed: Stopped
- Transmission: Warmed-up
 - A/T models
 - With CONSULT-III: Drive vehicle until "ATF TEMP SE 1" in "DATA MONITOR" mode of "A/T" system indicates less than 0.9V.
 - Without CONSULT-III: Drive vehicle for 10 minutes.
 - M/T models
 - Drive vehicle for 10 minutes.

Do you have CONSULT-III?

- YES >> GO TO 2.
NO >> GO TO 3.

2. PERFORM IDLE AIR VOLUME LEARNING

 With CONSULT-III

1. Perform Accelerator Pedal Released Position Learning. Refer to [EC-18, "ACCELERATOR PEDAL RELEASED POSITION LEARNING : Special Repair Requirement"](#).
2. Perform Throttle Valve Closed Position Learning. [EC-18, "THROTTLE VALVE CLOSED POSITION LEARNING : Special Repair Requirement"](#).
3. Start engine and warm it up to normal operating temperature.
4. Select "IDLE AIR VOL LEARN" in "WORK SUPPORT" mode.
5. Touch "START" and wait 20 seconds.

Is "CMPLT" displayed on CONSULT-III screen?

- YES >> GO TO 4.
NO >> GO TO 5.

3. PERFORM IDLE AIR VOLUME LEARNING

 Without CONSULT-III**NOTE:**

- It is better to count the time accurately with a clock.
- It is impossible to switch the diagnostic mode when an accelerator pedal position sensor circuit has a malfunction.

INSPECTION AND ADJUSTMENT

[VQ37VHR]

< BASIC INSPECTION >

1. Perform Accelerator Pedal Released Position Learning. Refer to [EC-18. "ACCELERATOR PEDAL RELEASED POSITION LEARNING : Special Repair Requirement"](#).
2. Perform Throttle Valve Closed Position Learning. [EC-18. "THROTTLE VALVE CLOSED POSITION LEARNING : Special Repair Requirement"](#).
3. Start engine and warm it up to normal operating temperature.
4. Turn ignition switch OFF and wait at least 10 seconds.
5. Confirm that accelerator pedal is fully released, turn ignition switch ON and wait 3 seconds.
6. Repeat the following procedure quickly five times within 5 seconds.
 - Fully depress the accelerator pedal.
 - Fully release the accelerator pedal.
7. Wait 7 seconds, fully depress the accelerator pedal for approx. 20 seconds until the MIL stops blinking and illuminates.
8. Fully release the accelerator pedal within 3 seconds after the MIL illuminates.
9. Start engine and let it idle.
10. Wait 20 seconds.

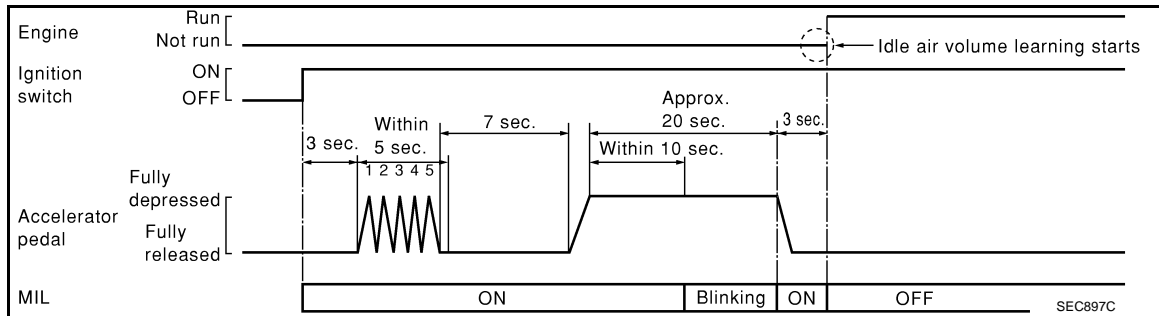

>> GO TO 4.

4. CHECK IDLE SPEED AND IGNITION TIMING

1. Start engine and warm it up to normal operating temperature.
2. Let it idle for 20 seconds.
3. Rev up the engine two or three times and make sure that idle speed and ignition timing are within the specifications. Refer to [EC-612. "Idle Speed"](#) and [EC-612. "Ignition Timing"](#).

Is the inspection result normal?

YES >> INSPECTION END

NO >> GO TO 5.

5. DETECT MALFUNCTIONING PART-I

Check the following

- Check that throttle valve is fully closed.
- Check PCV valve operation.
- Check that downstream of throttle valve is free from air leakage.

Is the inspection result normal?

YES >> GO TO 6.

NO >> Repair or replace malfunctioning part.

6. DETECT MALFUNCTIONING PART-II

Engine component parts and their installation condition are questionable. Check and eliminate the cause of the incident.

It is useful to perform "TROUBLE DIAGNOSIS - SPECIFICATION VALUE". Refer to [EC-132. "Description"](#).

If any of the following conditions occur after the engine has started, eliminate the cause of the incident and perform Idle Air Volume Learning again:

- Engine stalls.
- Erroneous idle.

>> INSPECTION END

VVEL CONTROL SHAFT POSITION SENSOR ADJUSTMENT

INSPECTION AND ADJUSTMENT

< BASIC INSPECTION >

[VQ37VHR]

VVEL CONTROL SHAFT POSITION SENSOR ADJUSTMENT : Description

INFOID:000000005151638

VVEL control shaft position sensor adjustment is an operation to adjust the initial position angle that is the basis for the VVEL control shaft position sensor.

It must be performed each time VVEL actuator sub assembly is replaced.

CAUTION:

- It must be performed only on the replaced bank side.
- It must not be performed except when VVEL actuator sub assembly is replaced. If by any chance the adjustment is performed, replace VVEL actuator sub assembly.

VVEL CONTROL SHAFT POSITION SENSOR ADJUSTMENT : Special Repair Requirement

INFOID:000000005151639

1. START

Do you have CONSULT-III?

Do you have CONSULT-III?

YES >> GO TO 2.

NO >> GO TO 3.

2. PERFORM VVEL CONTROL SHAFT POSITION SENSOR ADJUSTMENT

With CONSULT-III

1. Turn ignition switch ON.
2. Select "VVEL POS SEN ADJ PREP" in "WORK SUPPORT" mode with CONSULT-III.
3. Touch "Start" and wait a few seconds.
4. Make sure the "CMPLT" is displayed on CONSULT-III screen.
5. Select "VVEL POSITION SEN- B1" or "VVEL POSITION SEN- B2" in "DATA MONITOR" mode with CONSULT-III.
6. Loosen the VVEL control shaft position sensor mounting bolt (1).
7. Turn the VVEL control shaft position sensor (2) right and left while monitoring the output voltage of "VVEL POSITION SEN- B1" or "VVEL POSITION SEN- B2" and adjust the output voltage to be within the standard value.

Voltage : 500 ± 48 mV

8. Tighten the VVEL control shaft position sensor mounting bolt.

 **: 7.0 N•m (0.71 kg-m, 62 in-lb)**

9. Reconfirm that the output voltage of "VVEL POSITION SEN- B1" or "VVEL POSITION SEN- B2" is within the standard value.

Voltage : 500 ± 48 mV

NOTE:

If it varies from the standard value after the bolt is tightened, perform steps 6 to 8 again.

10. Turn ignition switch OFF and wait at least 10 seconds.
11. Start engine and warm it up to normal operating temperature.
12. Turn ignition switch OFF and wait at least 10 seconds.
13. Perform idle air volume learning. Refer to [EC-19. "IDLE AIR VOLUME LEARNING : Special Repair Requirement"](#).

>> INSPECTION END

3. PERFORM VVEL CONTROL SHAFT POSITION SENSOR ADJUSTMENT

Without CONSULT-III

1. Disconnect VVEL control shaft position sensor harness connector.
2. Remove VVEL actuator motor relay.
3. Turn ignition switch ON, wait at least 5 seconds and then turn OFF.

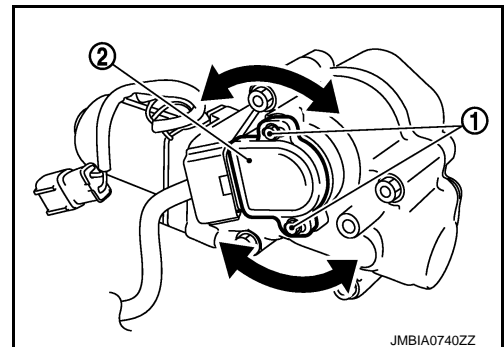

INSPECTION AND ADJUSTMENT

[VQ37VHR]

< BASIC INSPECTION >

4. Reconnect all harness connectors disconnected.
5. Install VVEL actuator motor relay.
6. Turn ignition switch ON and wait at least 5 seconds.
7. Loosen the VVEL control shaft position sensor mounting bolt (1).
8. Turn the VVEL control shaft position sensor (2) right and left while monitoring the output voltage between the VVEL control module terminals with a tester and adjust the output voltage to be within the standard value.

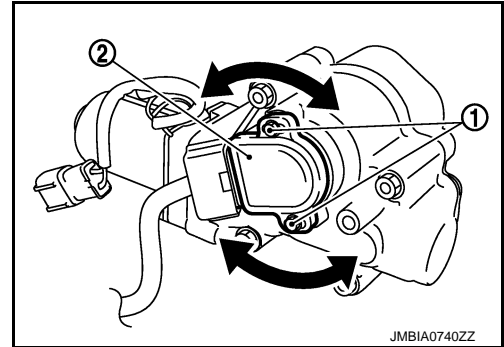

VVEL control module				Voltage
Bank	Connector	+	-	
		Terminal	Terminal	
1	E15	3	4	500 ± 48 mV
2		5	6	

9. Tighten the VVEL control shaft position sensor mounting bolt.



: 7.0 N•m (0.71 kg-m, 62 in-lb)

10. Reconfirm that the output voltage of VVEL control shaft position sensor is within the standard value.

VVEL control module				Voltage
Bank	Connector	+	-	
		Terminal	Terminal	
1	E15	3	4	500 ± 48 mV
2		5	6	

NOTE:

If it varies from the standard value after the bolt is tightened, perform steps 7 to 9 again.

11. Turn ignition switch OFF and wait at least 10 seconds.
12. Start engine and warm it up to normal operating temperature.
13. Turn ignition switch OFF and wait at least 10 seconds.
14. Perform idle air volume learning. Refer to [EC-19, "IDLE AIR VOLUME LEARNING : Special Repair Requirement"](#).

>> INSPECTION END

MIXTURE RATIO SELF-LEARNING VALUE CLEAR

MIXTURE RATIO SELF-LEARNING VALUE CLEAR : Description

INFOID:000000005151640

This describes how to erase the mixture ratio self-learning value. For the actual procedure, follow the instructions in "Diagnosis Procedure".

MIXTURE RATIO SELF-LEARNING VALUE CLEAR : Special Repair Requirement

INFOID:000000005151641

1.START

With CONSULT-III

1. Start engine and warm it up to normal operating temperature.
2. Select "SELF-LEARNING CONT" in "WORK SUPPORT" mode with CONSULT-III.

INSPECTION AND ADJUSTMENT

[VQ37VHR]

< BASIC INSPECTION >

3. Clear mixture ratio self-learning value by touching "CLEAR".

With GST

1. Start engine and warm it up to normal operating temperature.
2. Turn ignition switch OFF.
3. Disconnect mass air flow sensor (bank 1) harness connector.
4. Restart engine and let it idle for at least 5 seconds.
5. Stop engine and reconnect mass air flow sensor (bank 1) harness connector.
6. Select Service \$03 with GST. Make sure DTC P0102 is detected.
7. Select Service \$04 with GST to erase the DTC P0102.

>> END

A

EC

C

D

E

F

G

H

I

J

K

L

M

N

O

P

SYSTEM DESCRIPTION

ENGINE CONTROL SYSTEM

System Diagram

INFOID:000000005151642

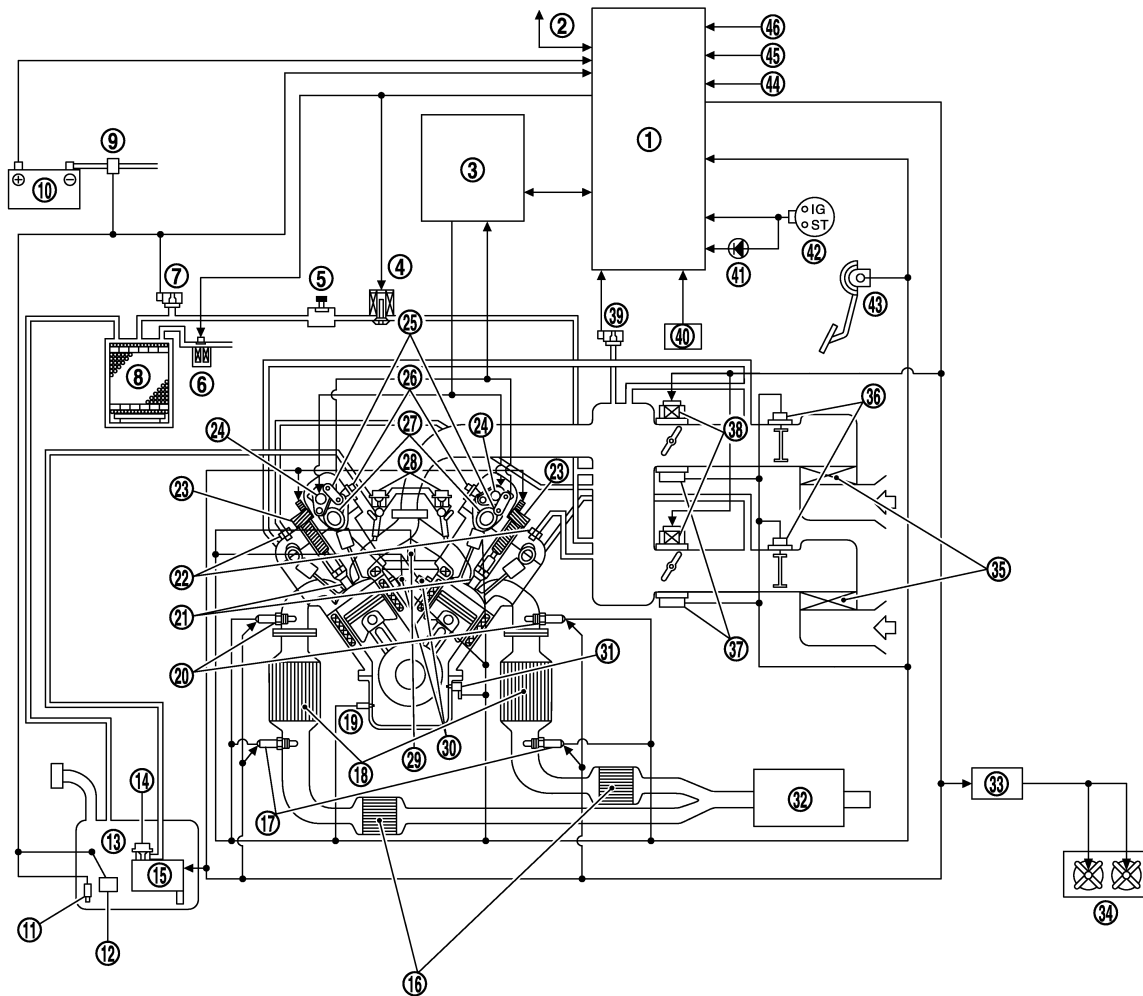

JMBIA2007ZZ

- | | | |
|--|---|-------------------------------------|
| 1. ECM | 2. Can communication | 3. VVEL control module |
| 4. EVAP canister purge volume control solenoid valve | 5. EVAP service port | 6. EVAP canister vent control valve |
| 7. EVAP control system pressure sensor | 8. EVAP canister | 9. Battery current sensor |
| 10. Battery | 11. Fuel tank temperature sensor | 12. Fuel level sensor |
| 13. Fuel tank | 14. Fuel pressure regulator | 15. Fuel pump |
| 16. Three way catalyst 2 | 17. Heated oxygen sensor 2 | 18. Three way catalyst 1 |
| 19. Engine oil temperature sensor | 20. A/F sensor 1 | 21. Spark plug |
| 22. PCV valve | 23. Ignition coil (with power transistor) | 24. VVEL actuator motor |

ENGINE CONTROL SYSTEM

[VQ37VHR]

< SYSTEM DESCRIPTION >

- | | | |
|--|--|---|
| 25. VVEL control shaft position sensor | 26. Intake valve timing control solenoid valve | 27. Camshaft position sensor (PHASE) |
| 28. Fuel damper | 29. Engine coolant temperature sensor | 30. Knock sensor |
| 31. Crankshaft position sensor (POS) | 32. Muffler | 33. Cooling fan control module |
| 34. Cooling fan | 35. Air cleaner | 36. Mass air flow sensor [with intake air temperature sensor(bank 1)] |
| 37. Electric throttle control actuator | 38. Throttle position sensor | 39. Manifold absolute pressure (MAP) sensor |
| 40. Brake booster pressure sensor | 41. MIL | 42. Ignition switch |
| 43. Accelerator pedal position sensor | 44. Power steering pressure sensor | 45. Refrigerant pressure sensor |
| 46. PNP signal | | |

A

EC

C

D

System Description

INFOID:000000005151643

ECM performs various controls such as fuel injection control and ignition timing control.

E

Component Parts Location

INFOID:000000005151644

F

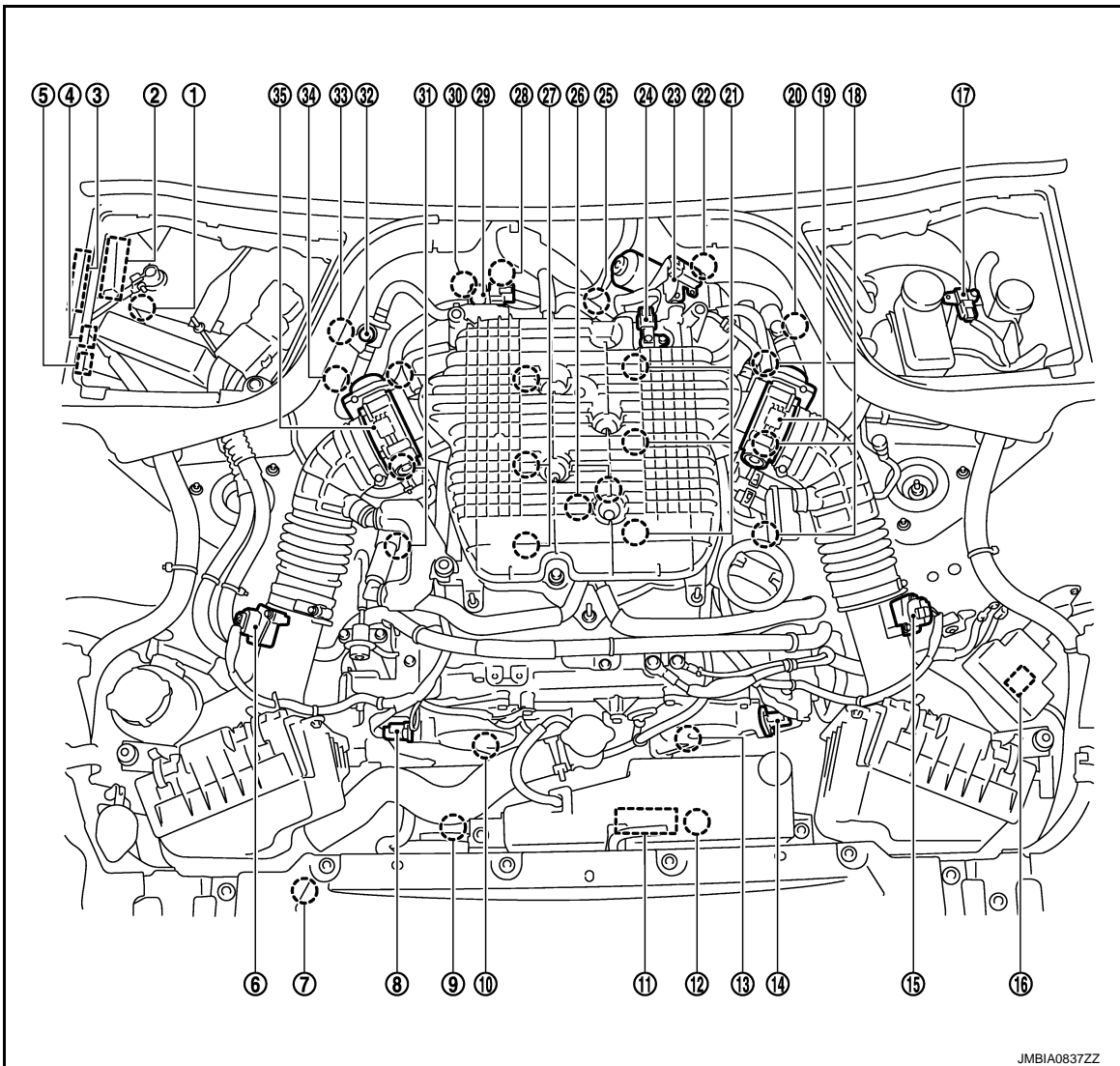

G

H

I

J

K

L

M

N

O

P

- | | | |
|---------------------------|------------------------------|---|
| 1. Battery current sensor | 2. IPDM E/R | 3. VVEL control module |
| 4. Cooling fan relay | 5. VVEL actuator motor relay | 6. Mass air flow sensor (with intake air temperature sensor) (bank 1) |

ENGINE CONTROL SYSTEM

[VQ37VHR]

< SYSTEM DESCRIPTION >

- | | | |
|---|---|---|
| 7. Refrigerant pressure sensor | 8. Camshaft position sensor (PHASE) (bank 1) | 9. Cooling fan motor-2 |
| 10. Intake valve timing control solenoid valve (bank 1) | 11. Cooling fan control module | 12. Cooling fan motor-1 |
| 13. Intake valve timing control solenoid valve (bank 2) | 14. Camshaft position sensor (PHASE) (bank 2) | 15. Mass air flow sensor (bank 2) |
| 16. ICC brake hold relay (ICC models) | 17. Brake booster pressure sensor | 18. Ignition coil (with power transistor and spark plug) (bank 2) |
| 19. Electric throttle control actuator (bank 2) | 20. A/F sensor 1 (bank 2) | 21. Fuel injector (bank 2) |
| 22. VVEL control shaft position sensor (bank 2) | 23. VVEL actuator motor (bank 2) | 24. Manifold absolute pressure (MAP) sensor |
| 25. Engine coolant temperature sensor | 26. Knock sensor | 27. Fuel injector (bank 1) |
| 28. VVEL actuator motor (bank 1) | 29. EVAP canister purge volume control solenoid valve | 30. VVEL control shaft position sensor (bank 1) |
| 31. Ignition coil (with power transistor and spark plug) (bank 1) | 32. EVAP service port | 33. A/F sensor 1 (bank 1) |
| 34. Crankshaft position sensor (POS) | 35. Electric throttle control actuator (bank 1) | |

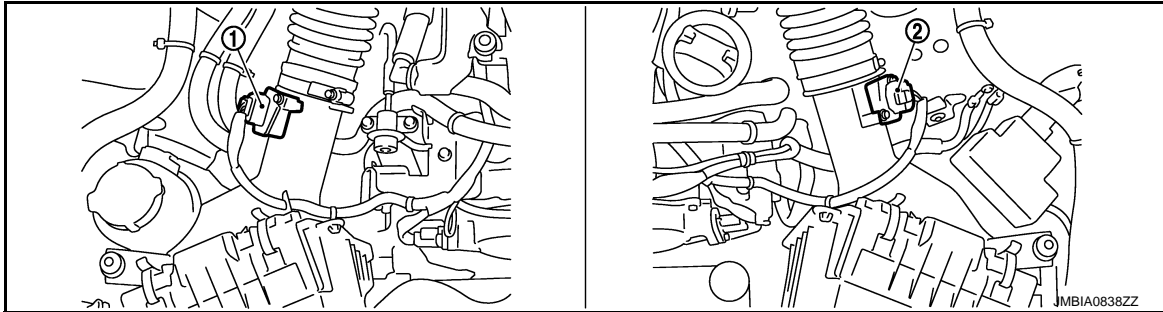

1. Mass air flow sensor (with intake air temperature sensor) (bank 1) 2. Mass air flow sensor (bank 2)

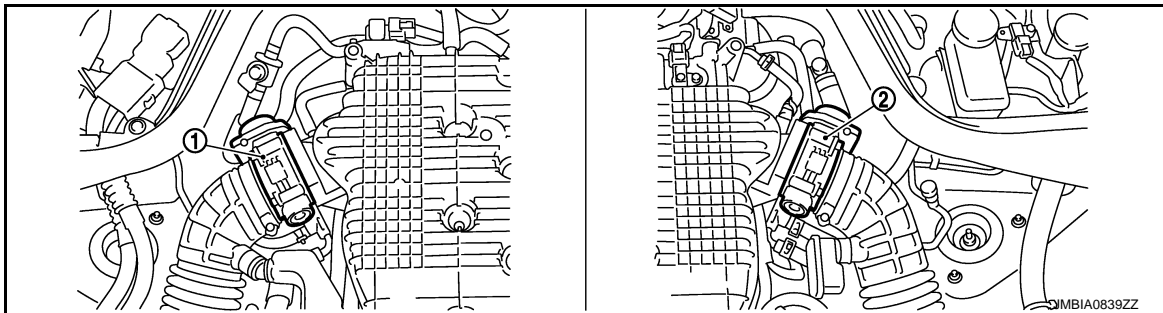

1. Electric throttle control actuator (bank 1) 2. Electric throttle control actuator (bank 2)

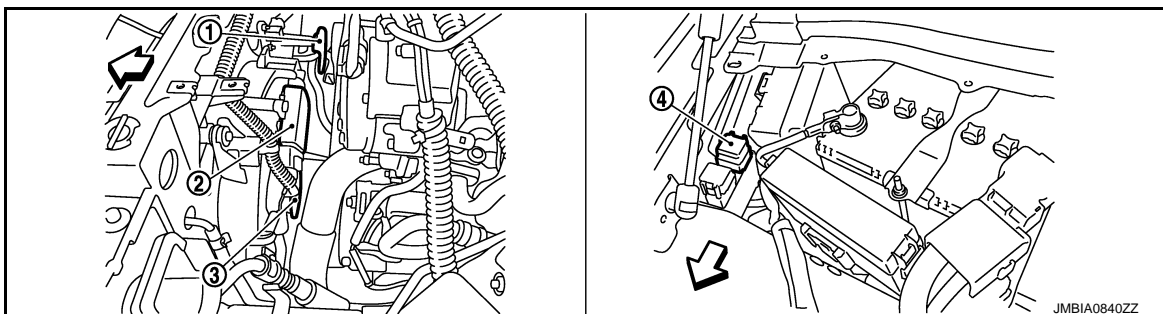

ENGINE CONTROL SYSTEM

< SYSTEM DESCRIPTION >

[VQ37VHR]

←: Vehicle front

1. Cooling fan motor-2
2. Cooling fan control module
3. Cooling fan motor-1
4. Cooling fan relay

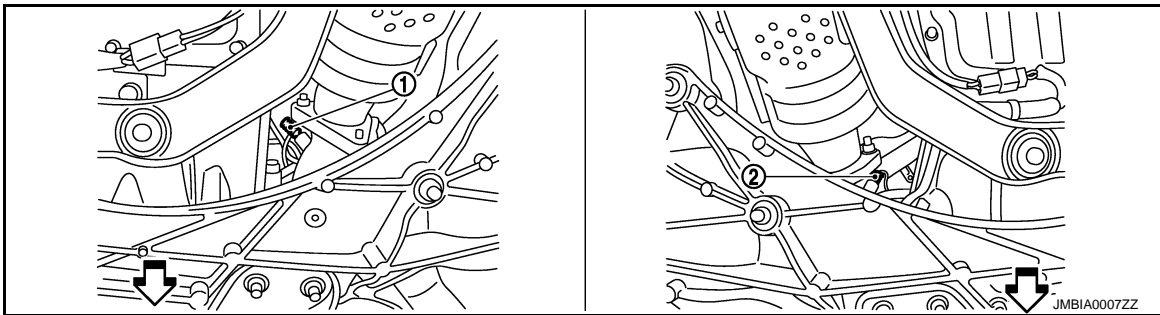
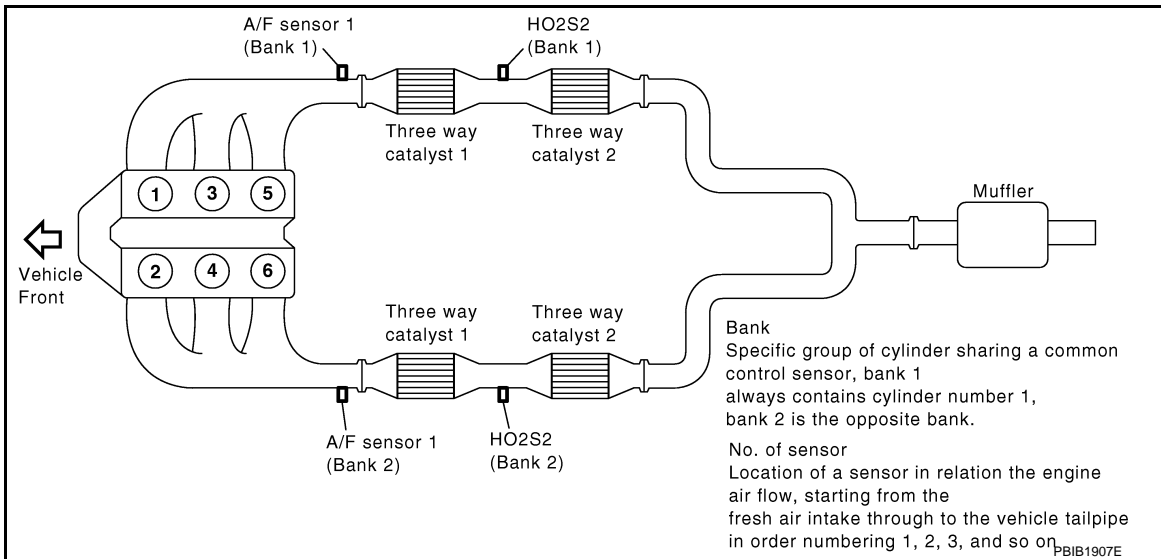

←: Vehicle front

1. A/F sensor 1 (bank 1)
2. A/F sensor 1 (bank 2)

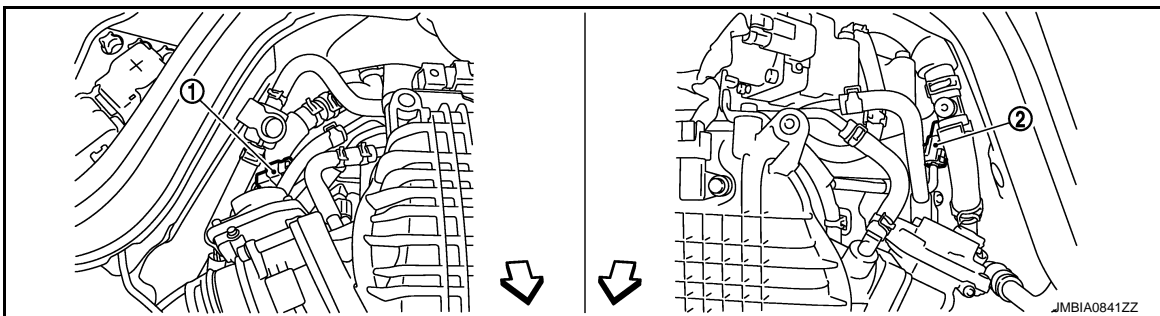

←: Vehicle front

1. A/F sensor 1 (bank 1) harness connector
2. A/F sensor 1 (bank 2) harness connector

ENGINE CONTROL SYSTEM

< SYSTEM DESCRIPTION >

[VQ37VHR]

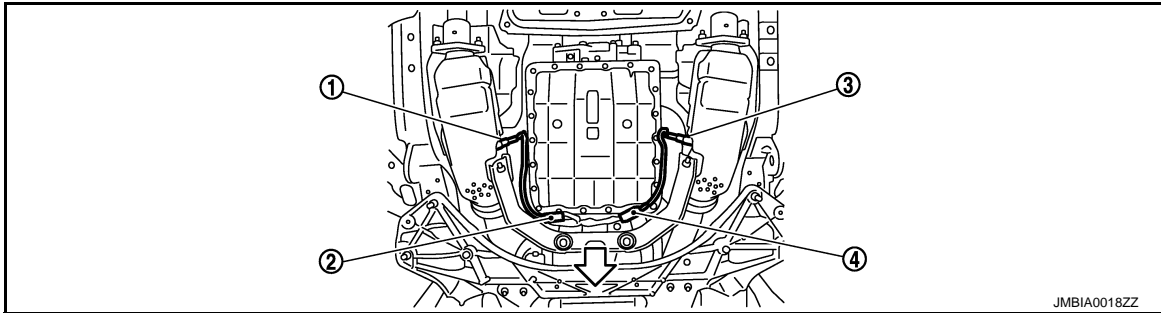

⇐ : Vehicle front

1. Heated oxygen sensor 2 (bank 2)
2. Heated oxygen sensor 2 (bank 2) harness connector
3. Heated oxygen sensor 2 (bank 1)
4. Heated oxygen sensor 2 (bank 1) harness connector

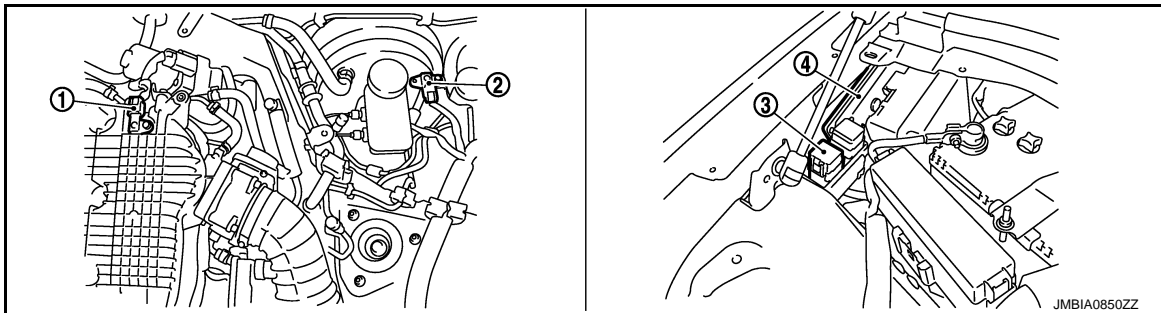

1. Manifold absolute pressure (MAP) sensor
2. Brake booster pressure sensor
3. VVEL actuator motor relay sensor
4. VVEL control module



⇐ : Vehicle front

1. VVEL control shaft position sensor (bank 1)
2. VVEL actuator motor (bank 1)
3. VVEL actuator motor (bank 2)
4. VVEL control shaft position sensor (bank 2)

ENGINE CONTROL SYSTEM

< SYSTEM DESCRIPTION >

[VQ37VHR]

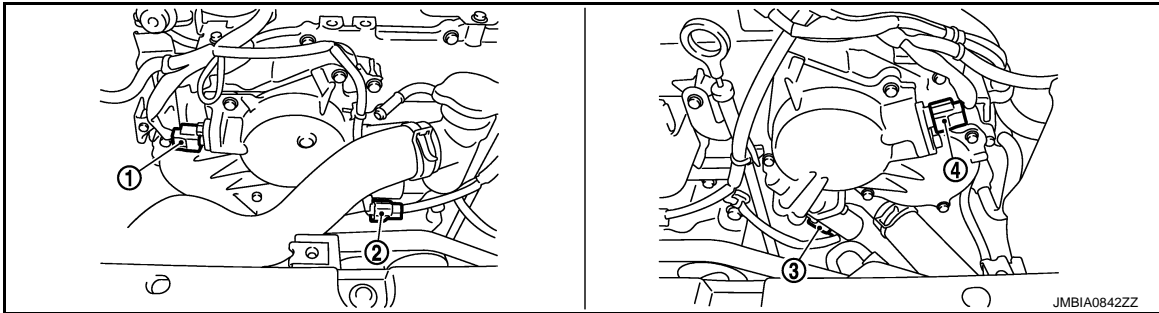

- | | | |
|--|--|--|
| 1. Camshaft position sensor (PHASE) (bank 1) | 2. Intake valve timing control solenoid valve (bank 1) harness connector | 3. Intake valve timing control solenoid valve (bank 2) harness connector |
| 4. Camshaft position sensor (PHASE) (bank 2) | | |

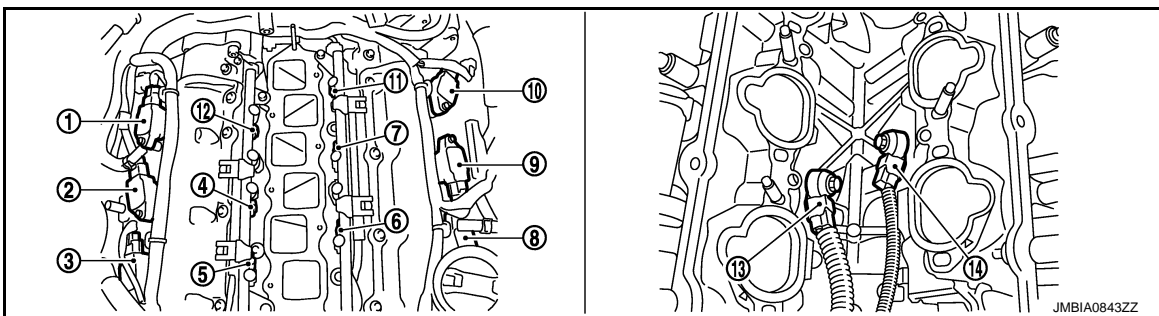

- | | | |
|--|---|---|
| 1. Ignition coil No.5 (with power transistor) | 2. Ignition coil No.3 (with power transistor) | 3. Ignition coil No.1 (with power transistor) |
| 4. Fuel injector No.3 | 5. Fuel injector No.1 | 6. Fuel injector No.2 |
| 7. Fuel injector No.4 | 8. Ignition coil No.2 (with power transistor) | 9. Ignition coil No.4 (with power transistor) |
| 10. Ignition coil No.6 (with power transistor) | 11. Fuel injector No.6 | 12. Fuel injector No.5 |
| 13. Knock sensor (bank 1) | 14. Knock sensor (bank 2) | |

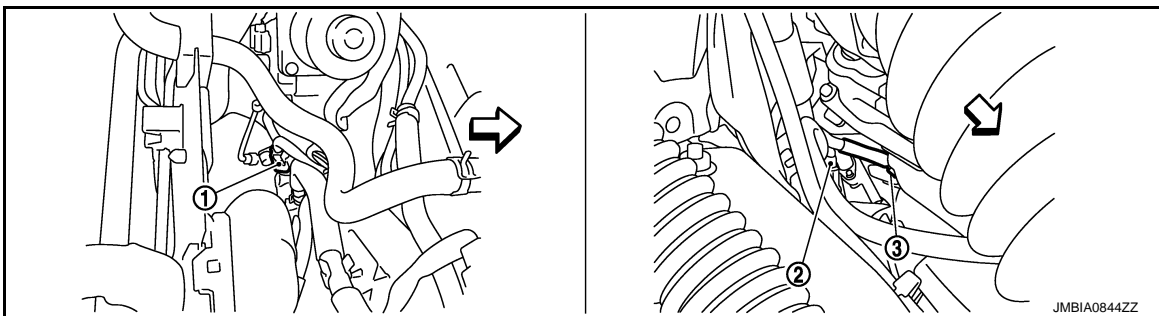

← : Vehicle front

- | | | |
|--------------------------------------|--------------------------|-------------------------------------|
| 1. Engine coolant temperature sensor | 2. A/F sensor 1 (bank 1) | 3. Crankshaft position sensor (POS) |
|--------------------------------------|--------------------------|-------------------------------------|

A
EC
C
D
E
F
G
H
I
J
K
L
M
N
O
P

ENGINE CONTROL SYSTEM

< SYSTEM DESCRIPTION >

[VQ37VHR]

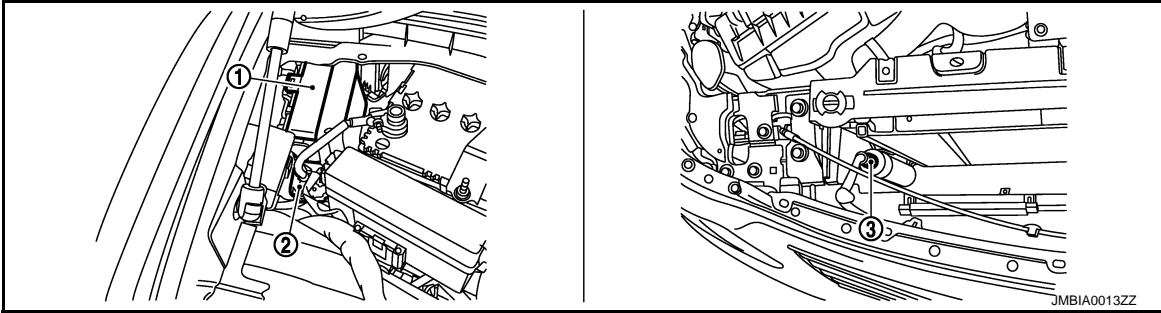

1. IPDM E/R 2. Battery current sensor 3. Refrigerant pressure sensor

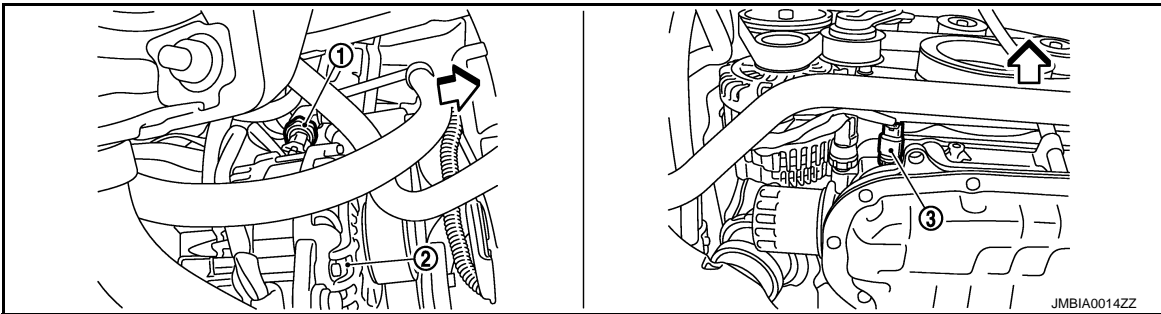

↙ : Vehicle front

1. Power steering pressure sensor 2. Alternator 3. Engine oil temperature sensor

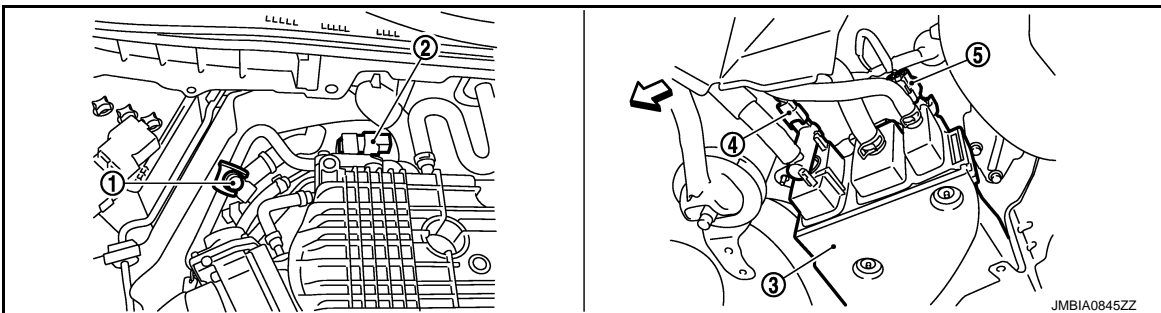

↙ : Vehicle front

1. EVAP service port 2. EVAP canister purge volume control 3. EVAP canister solenoid valve
4. EVAP canister vent control valve 5. EVAP control system pressure sensor

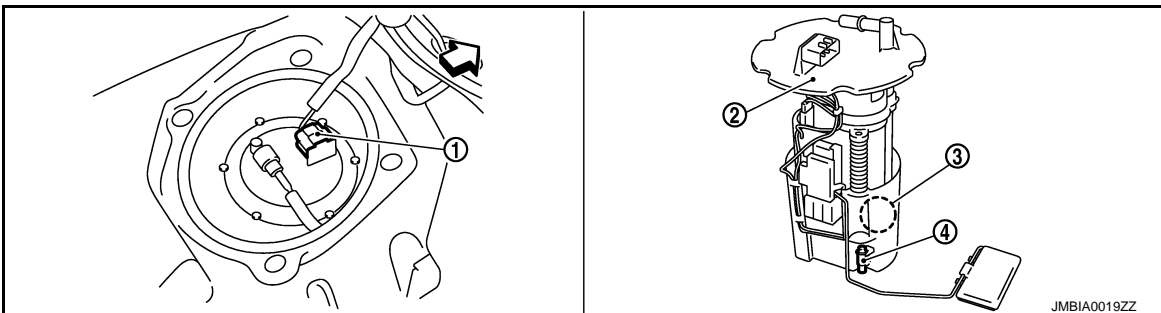

ENGINE CONTROL SYSTEM

< SYSTEM DESCRIPTION >

[VQ37VHR]

↶: Vehicle front

1. Fuel level sensor unit and fuel pump
2. Fuel level sensor unit and fuel pump
3. Fuel pressure regulator harness connector
4. Fuel tank temperature sensor



1. Accelerator pedal position sensor
2. ECM

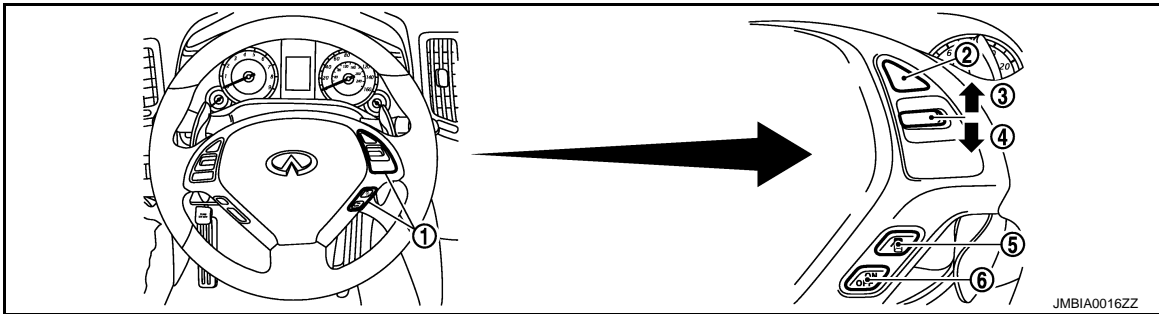

1. ICC steering switch
2. CANCEL switch
3. RESUME/ACCELERATE switch
4. SET/COAST switch
5. DISTANCE switch
6. MAIN switch

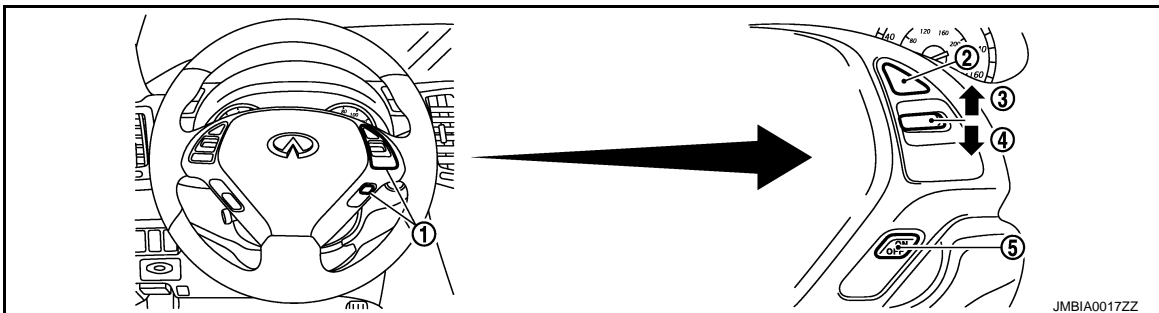

1. ASCD steering switch
2. CANCEL switch
3. RESUME/ACCELERATE switch
4. SET/COAST switch
5. MAIN switch

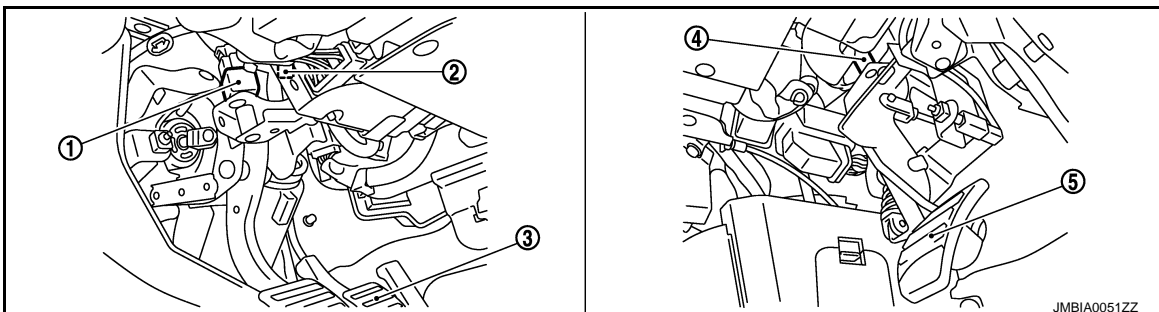

A
EC
C
D
E
F
G
H
I
J
K
L
M
N
O
P

ENGINE CONTROL SYSTEM

[VQ37VHR]

< SYSTEM DESCRIPTION >

1. Stop lamp switch
2. ASCD brake switch (ASCD models) 3. Brake pedal
ICC brake switch (ICC models)
4. ASCD clutch switch (ASCD models) 5. Clutch pedal
ICC clutch switch (ICC models)

Component Description

INFOID:000000005151645

Component	Reference
A/F sensor 1	EC-201, "Description"
A/F sensor 1 heater	EC-156, "Description"
Accelerator pedal position sensor	EC-463, "Description"
ASCD brake switch	EC-434, "Description"
ASCD steering switch	EC-427, "Description"
Battery current sensor	EC-414, "Description"
Brake booster pressure sensor	EC-354, "Description"
Camshaft position sensor (PHASE)	EC-273, "Description"
Cooling fan control module	EC-486, "Description"
Cooling fan motor	EC-486, "Description"
Crankshaft position sensor (POS)	EC-269, "Description"
Electric throttle control actuator	EC-405, "Description"
Engine coolant temperature sensor	EC-187, "Description"
Engine oil temperature sensor	EC-250, "Description"
EVAP canister purge volume control solenoid valve	EC-293, "Description"
EVAP canister vent control valve	EC-301, "Description"
EVAP control system pressure sensor	EC-309, "Description"
Fuel injector	EC-492, "Description"
Fuel level sensor	EC-336, "Description"
Fuel pump	EC-495, "Description"
Fuel tank temperature sensor	EC-244, "Description"
Heated oxygen sensor 2	EC-216, "Description"
Heated oxygen sensor 2 heater	EC-159, "Description"
ICC brake switch	EC-441, "Description"
ICC steering switch	EC-430, "Description"
Ignition signal	EC-503, "Description"
Intake air temperature sensor	EC-182, "Description"
Intake valve timing control solenoid valve	EC-162, "Description"
Knock sensor	EC-266, "Description"
Manifold absolute pressure (MAP) sensor	EC-178, "Description"
Mass air flow sensor	EC-165, "Description"
Park/neutral position switch (M/T) TCM (A/T)	EC-367, "Description"
PCV valve	EC-514, "Description"
Power steering pressure sensor	EC-351, "Description"
Refrigerant pressure sensor	EC-516, "Description"
Stop lamp switch	EC-460, "Description"
Throttle control motor	EC-402, "Description"

ENGINE CONTROL SYSTEM

< SYSTEM DESCRIPTION >

[VQ37VHR]

Component	Reference
Throttle control motor relay	EC-410. "Description"
Throttle position sensor	EC-190. "Description"
VVEL actuator motor	EC-380. "Description"
VVEL actuator motor relay	EC-384. "Description"
VVEL control module	EC-453. "Description"
VVEL control shaft position sensor	EC-376. "Description"

A

EC

C

D

E

F

G

H

I

J

K

L

M

N

O

P

MULTIPOINT FUEL INJECTION SYSTEM

< SYSTEM DESCRIPTION >

[VQ37VHR]

MULTIPOINT FUEL INJECTION SYSTEM

System Diagram

INFOID:000000005151646

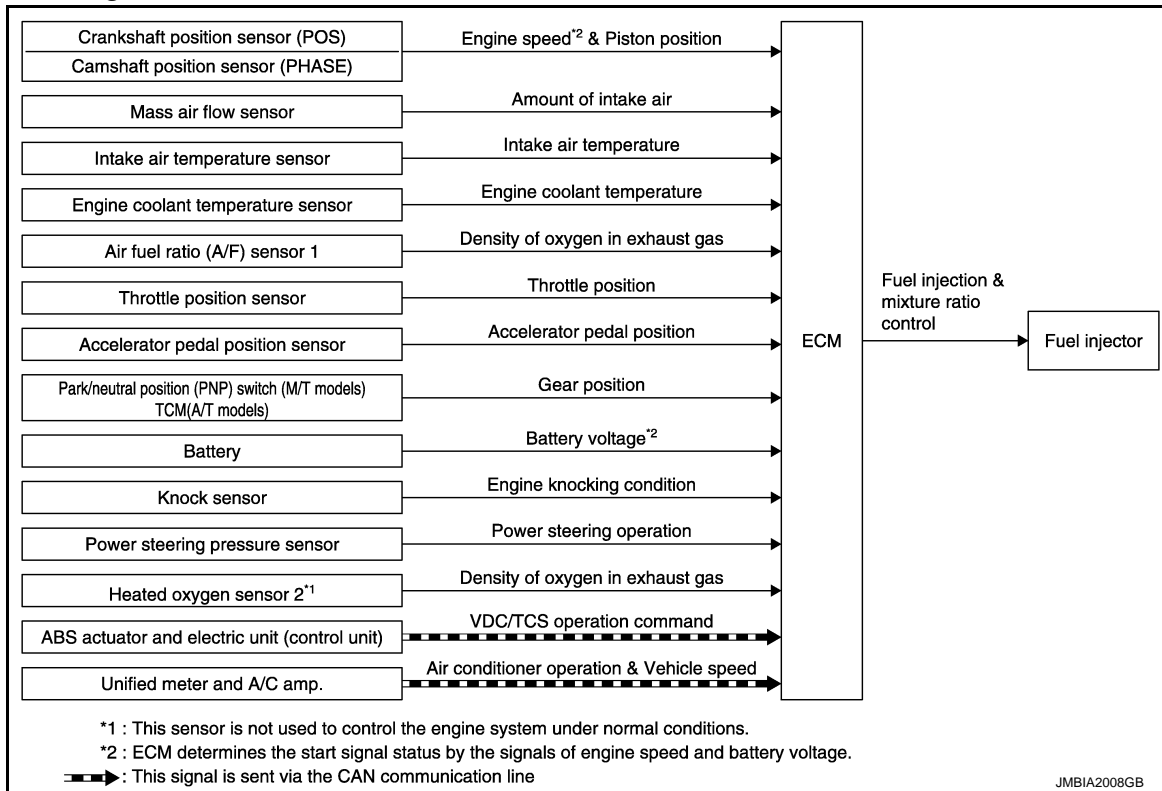

System Description

INFOID:000000005151647

INPUT/OUTPUT SIGNAL CHART

Sensor	Input signal to ECM	ECM function	Actuator
Crankshaft position sensor (POS)	Engine speed ^{*3}	Fuel injection & mixture ratio control	Fuel injector
Camshaft position sensor (PHASE)	Piston position		
Mass air flow sensor	Amount of intake air		
Intake air temperature sensor	Intake air temperature		
Engine coolant temperature sensor	Engine coolant temperature		
Air fuel ratio (A/F) sensor 1	Density of oxygen in exhaust gas		
Throttle position sensor	Throttle position		
Accelerator pedal position sensor	Accelerator pedal position		
Park/neutral position (PNP) switch (M/T models) TCM (A/T models)	Gear position		
Battery	Battery voltage ^{*3}		
Knock sensor	Engine knocking condition		
Power steering pressure sensor	Power steering operation		
Heated oxygen sensor 2 ^{*1}	Density of oxygen in exhaust gas		
ABS actuator and electric unit (control unit) ^{*2}	VDC/TCS operation command		
Unified meter and A/C amp.	Air conditioner operation ^{*2}		
	Vehicle speed ^{*2}		

*1: This sensor is not used to control the engine system under normal conditions.

MULTIPOINT FUEL INJECTION SYSTEM

[VQ37VHR]

< SYSTEM DESCRIPTION >

*2: This signal is sent to the ECM via the CAN communication line.

*3: ECM determines the start signal status by the signals of engine speed and battery voltage.

SYSTEM DESCRIPTION

The amount of fuel injected from the fuel injector is determined by the ECM. The ECM controls the length of time the valve remains open (injection pulse duration). The amount of fuel injected is a program value in the ECM memory. The program value is preset by engine operating conditions. These conditions are determined by input signals (for engine speed and intake air) from the crankshaft position sensor (POS), camshaft position sensor (PHASE) and the mass air flow sensor.

VARIOUS FUEL INJECTION INCREASE/DECREASE COMPENSATION

In addition, the amount of fuel injected is compensated to improve engine performance under various operating conditions as listed below.

<Fuel increase>

- During warm-up
- When starting the engine
- During acceleration
- Hot-engine operation
- When selector lever is changed from N to D (A/T models)
- High-load, high-speed operation

<Fuel decrease>

- During deceleration
- During high engine speed operation

MIXTURE RATIO FEEDBACK CONTROL (CLOSED LOOP CONTROL)

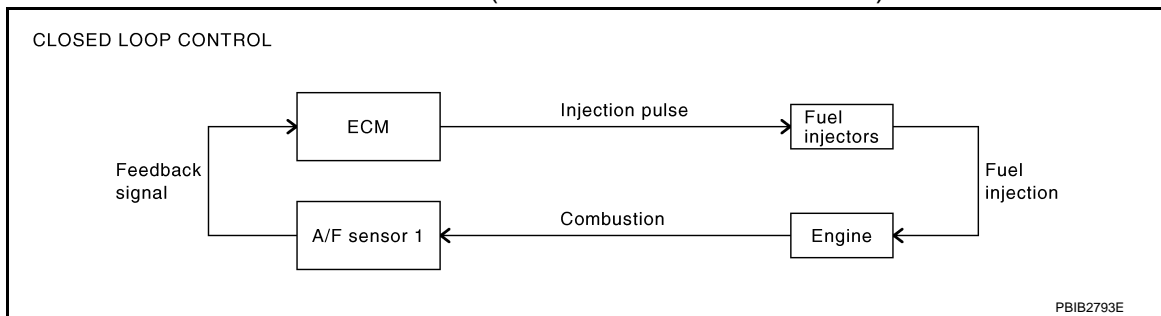

The mixture ratio feedback system provides the best air-fuel mixture ratio for driveability and emission control. The three way catalyst 1 can better reduce CO, HC and NOx emissions. This system uses A/F sensor 1 in the exhaust manifold to monitor whether the engine operation is rich or lean. The ECM adjusts the injection pulse width according to the sensor voltage signal. For more information about A/F sensor 1, refer to [EC-201, "Description"](#). This maintains the mixture ratio within the range of stoichiometric (ideal air-fuel mixture). This stage is referred to as the closed loop control condition.

Heated oxygen sensor 2 is located downstream of the three way catalyst 1. Even if the switching characteristics of A/F sensor 1 shift, the air-fuel ratio is controlled to stoichiometric by the signal from heated oxygen sensor 2.

• Open Loop Control

The open loop system condition refers to when the ECM detects any of the following conditions. Feedback control stops in order to maintain stabilized fuel combustion.

- Deceleration and acceleration
- High-load, high-speed operation
- Malfunction of A/F sensor 1 or its circuit
- Insufficient activation of A/F sensor 1 at low engine coolant temperature
- High engine coolant temperature
- During warm-up
- After shifting from N to D (A/T models)
- When starting the engine

MIXTURE RATIO SELF-LEARNING CONTROL

The mixture ratio feedback control system monitors the mixture ratio signal transmitted from A/F sensor 1. This feedback signal is then sent to the ECM. The ECM controls the basic mixture ratio as close to the theoretical mixture ratio as possible. However, the basic mixture ratio is not necessarily controlled as originally

MULTIPOINT FUEL INJECTION SYSTEM

[VQ37VHR]

< SYSTEM DESCRIPTION >

designed. Both manufacturing differences (i.e., mass air flow sensor hot wire) and characteristic changes during operation (i.e., fuel injector clogging) directly affect mixture ratio. Accordingly, the difference between the basic and theoretical mixture ratios is monitored in this system. This is then computed in terms of "injection pulse duration" to automatically compensate for the difference between the two ratios.

"Fuel trim" refers to the feedback compensation value compared against the basic injection duration. Fuel trim includes short-term fuel trim and long-term fuel trim.

"Short-term fuel trim" is the short-term fuel compensation used to maintain the mixture ratio at its theoretical value. The signal from A/F sensor 1 indicates whether the mixture ratio is RICH or LEAN compared to the theoretical value. The signal then triggers a reduction in fuel volume if the mixture ratio is rich, and an increase in fuel volume if it is lean.

"Long-term fuel trim" is overall fuel compensation carried out over time to compensate for continual deviation of the short-term fuel trim from the central value. Continual deviation will occur due to individual engine differences, wear over time and changes in the usage environment.

FUEL INJECTION TIMING

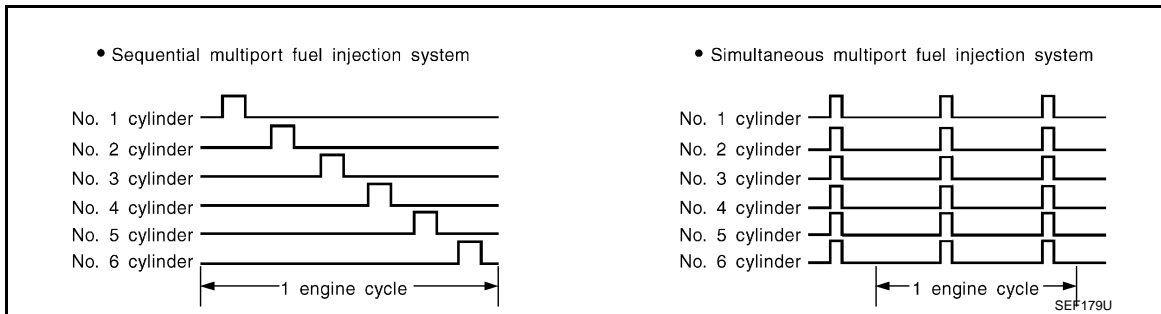

Two types of systems are used.

- **Sequential Multiport Fuel Injection System**
Fuel is injected into each cylinder during each engine cycle according to the firing order. This system is used when the engine is running.
- **Simultaneous Multiport Fuel Injection System**
Fuel is injected simultaneously into all six cylinders twice each engine cycle. In other words, pulse signals of the same width are simultaneously transmitted from the ECM.
The six injectors will then receive the signals two times for each engine cycle.
This system is used when the engine is being started and/or if the fail-safe system (CPU) is operating.

FUEL SHUT-OFF

Fuel to each cylinder is cut off during deceleration, operation of the engine at excessively high speeds or operation of the vehicle at excessively high speeds.

MULTIPOINT FUEL INJECTION SYSTEM

< SYSTEM DESCRIPTION >

[VQ37VHR]

Component Parts Location

INFOID:000000005151648

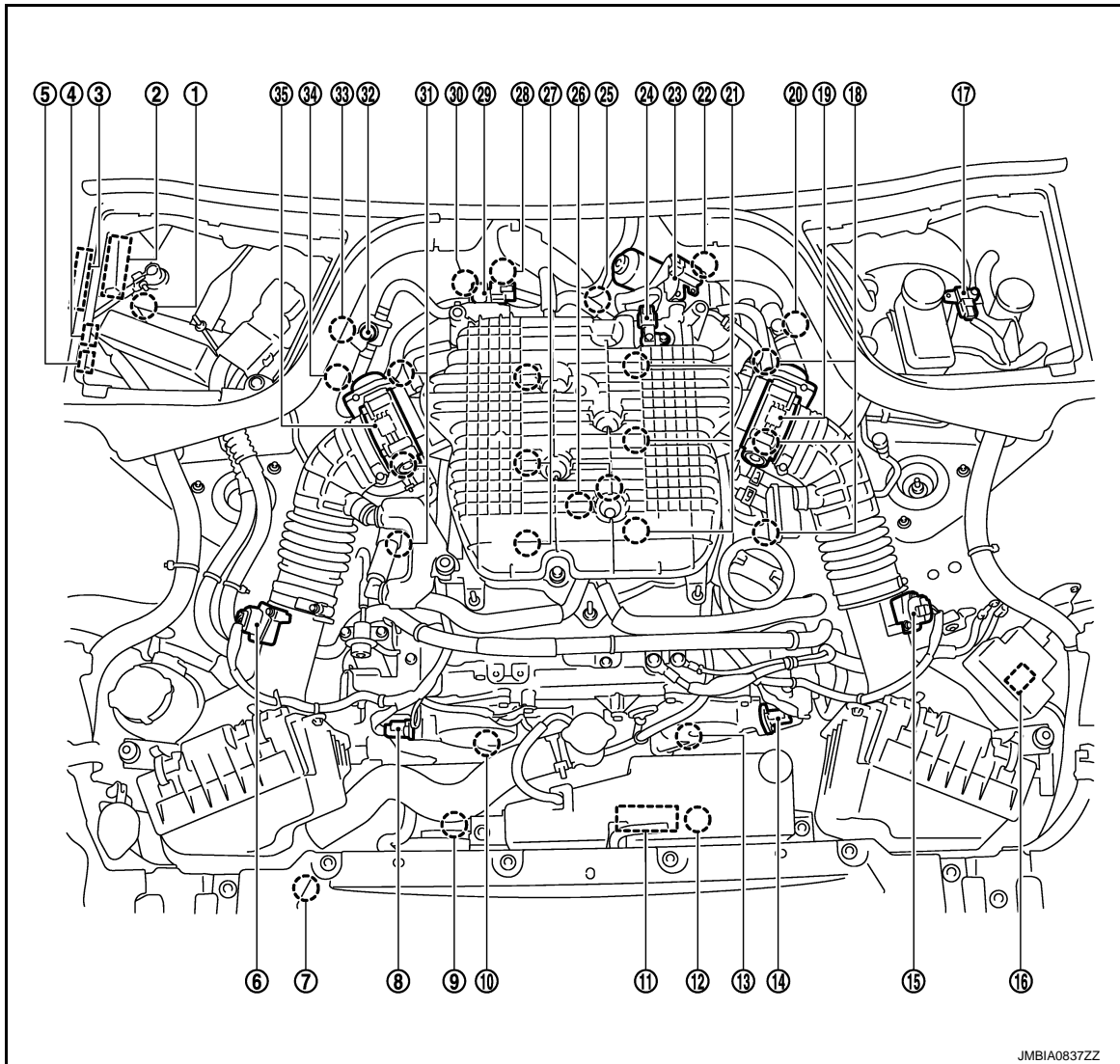

- | | | |
|---|---|---|
| 1. Battery current sensor | 2. IPDM E/R | 3. VVEL control module |
| 4. Cooling fan relay | 5. VVEL actuator motor relay | 6. Mass air flow sensor (with intake air temperature sensor) (bank 1) |
| 7. Refrigerant pressure sensor | 8. Camshaft position sensor (PHASE) (bank 1) | 9. Cooling fan motor-2 |
| 10. Intake valve timing control solenoid valve (bank 1) | 11. Cooling fan control module | 12. Cooling fan motor-1 |
| 13. Intake valve timing control solenoid valve (bank 2) | 14. Camshaft position sensor (PHASE) (bank 2) | 15. Mass air flow sensor (bank 2) |
| 16. ICC brake hold relay (ICC models) | 17. Brake booster pressure sensor | 18. Ignition coil (with power transistor and spark plug) (bank 2) |
| 19. Electric throttle control actuator (bank 2) | 20. A/F sensor 1 (bank 2) | 21. Fuel injector (bank 2) |
| 22. VVEL control shaft position sensor (bank 2) | 23. VVEL actuator motor (bank 2) | 24. Manifold absolute pressure (MAP) sensor |
| 25. Engine coolant temperature sensor | 26. Knock sensor | 27. Fuel injector (bank 1) |
| 28. VVEL actuator motor (bank 1) | 29. EVAP canister purge volume control solenoid valve | 30. VVEL control shaft position sensor (bank 1) |

MULTIPOINT FUEL INJECTION SYSTEM

[VQ37VHR]

< SYSTEM DESCRIPTION >

- | | | |
|---|---|---------------------------|
| 31. Ignition coil (with power transistor and spark plug (bank 1)) | 32. EVAP service port | 33. A/F sensor 1 (bank 1) |
| 34. Crankshaft position sensor (POS) | 35. Electric throttle control actuator (bank 1) | |

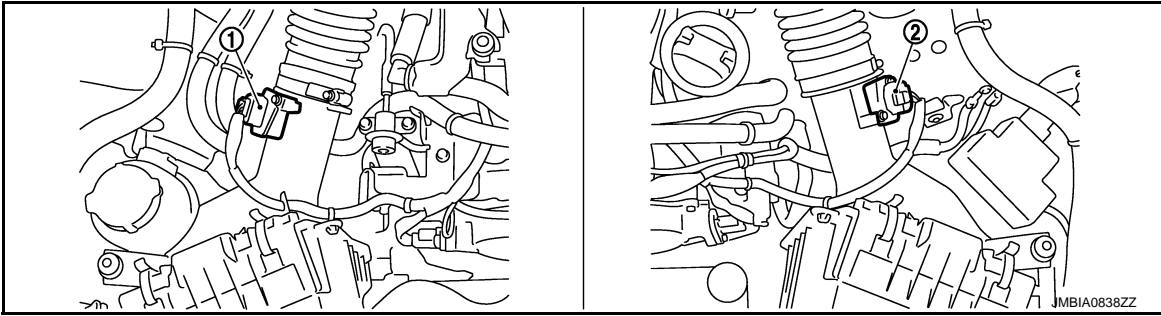

- | | |
|---|----------------------------------|
| 1. Mass air flow sensor (with intake air temperature sensor) (bank 1) | 2. Mass air flow sensor (bank 2) |
|---|----------------------------------|

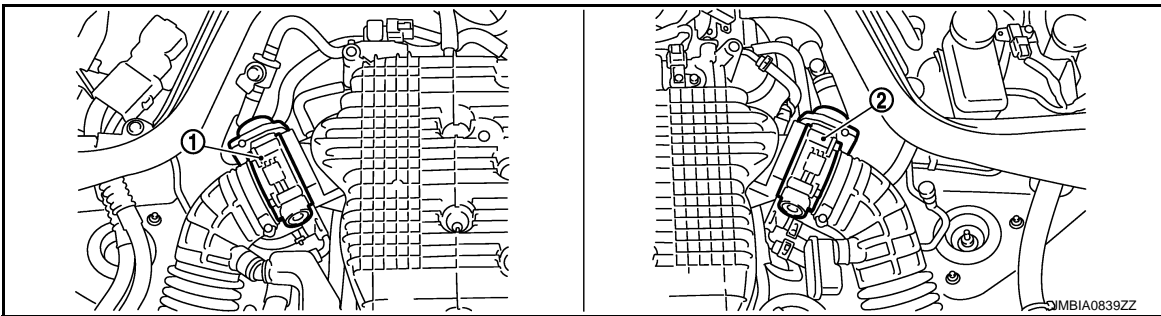

- | | |
|--|--|
| 1. Electric throttle control actuator (bank 1) | 2. Electric throttle control actuator (bank 2) |
|--|--|

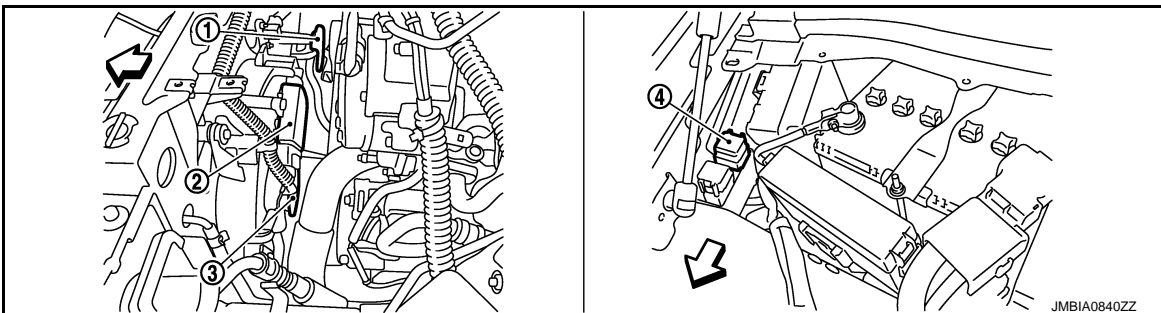

↖ : Vehicle front

- | | | |
|------------------------|-------------------------------|------------------------|
| 1. Cooling fan motor-2 | 2. Cooling fan control module | 3. Cooling fan motor-1 |
| 4. Cooling fan relay | | |

MULTIPOINT FUEL INJECTION SYSTEM

< SYSTEM DESCRIPTION >

[VQ37VHR]

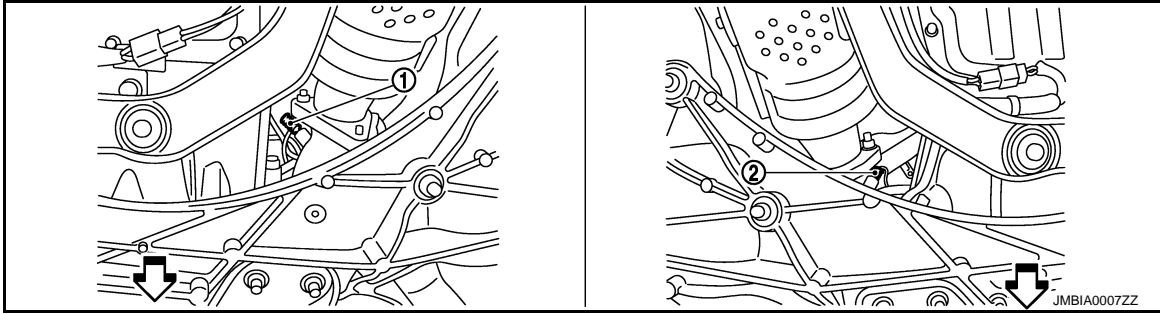
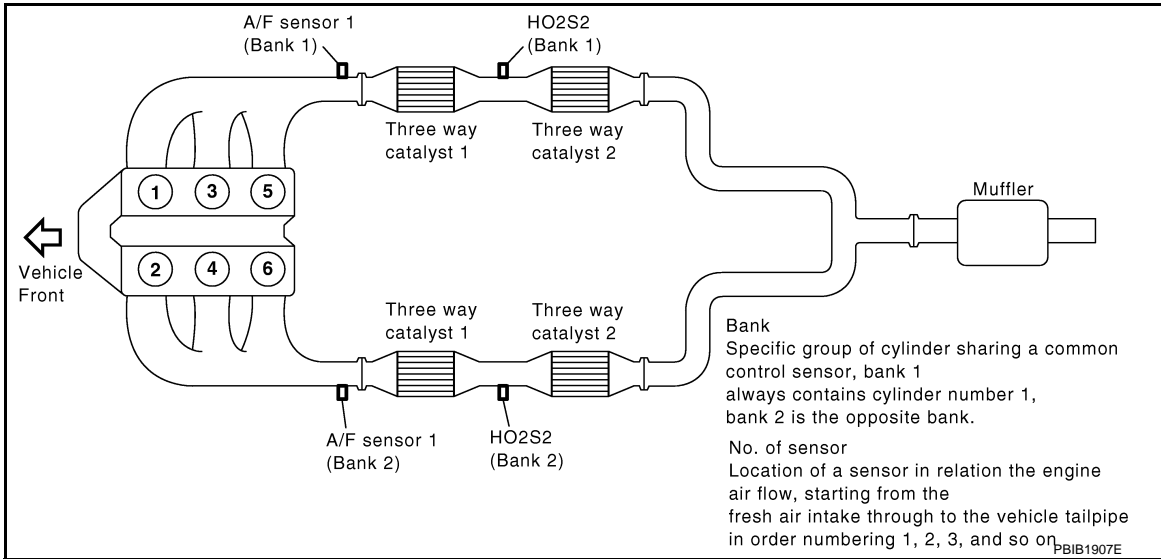

↔: Vehicle front

1. A/F sensor 1 (bank 1)
2. A/F sensor 1 (bank 2)

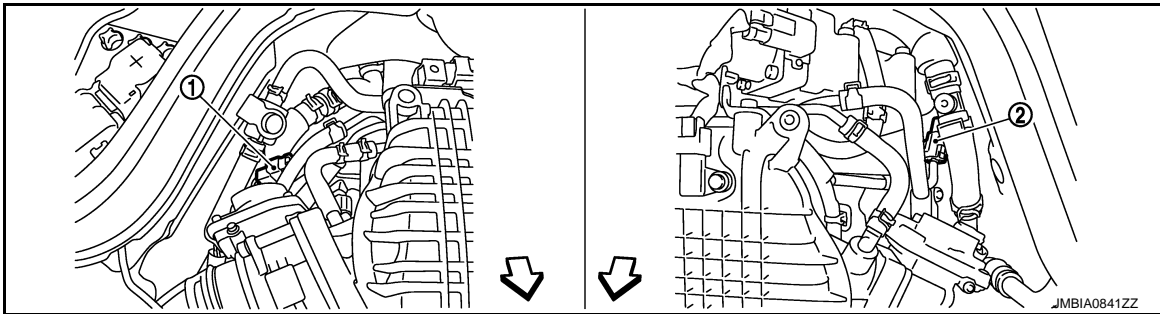

↔: Vehicle front

1. A/F sensor 1 (bank 1) harness connector
2. A/F sensor 1 (bank 2) harness connector

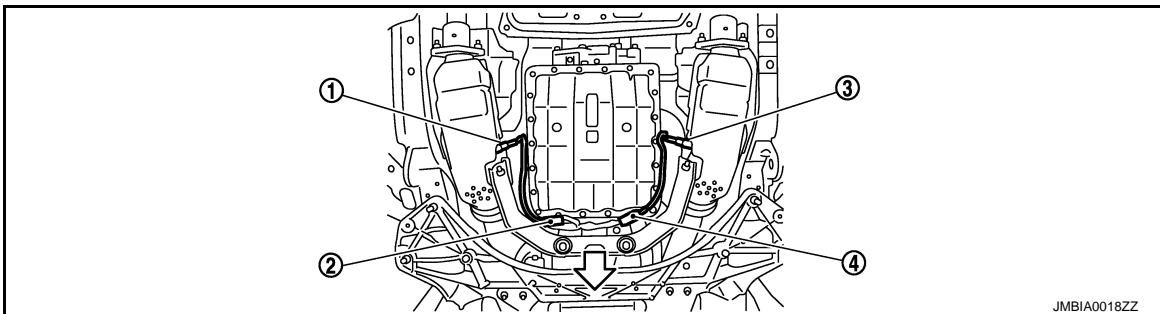

MULTIPOINT FUEL INJECTION SYSTEM

[VQ37VHR]

< SYSTEM DESCRIPTION >

↙ : Vehicle front

1. Heated oxygen sensor 2 (bank 2)
2. Heated oxygen sensor 2 (bank 2) harness connector
3. Heated oxygen sensor 2 (bank 1)
4. Heated oxygen sensor 2 (bank 1) harness connector

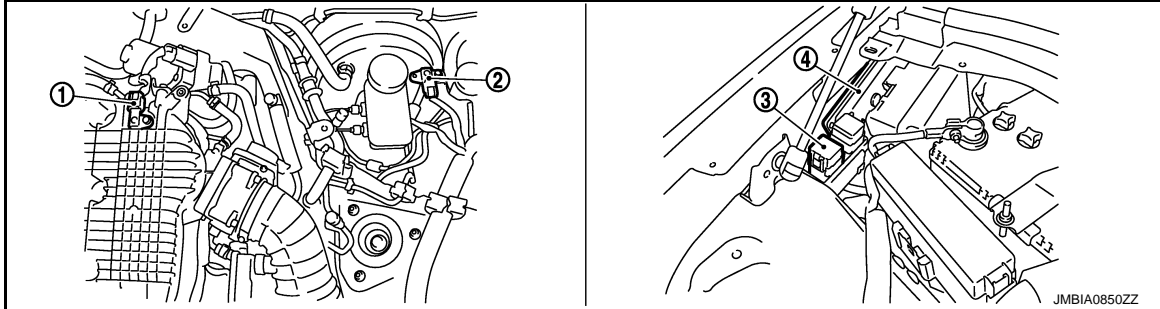

1. Manifold absolute pressure (MAP) sensor
2. Brake booster pressure sensor
3. VVEL actuator motor relay
4. VVEL control module



↙ : Vehicle front

1. VVEL control shaft position sensor (bank 1)
2. VVEL actuator motor (bank 1)
3. VVEL actuator motor (bank 2)
4. VVEL control shaft position sensor (bank 2)

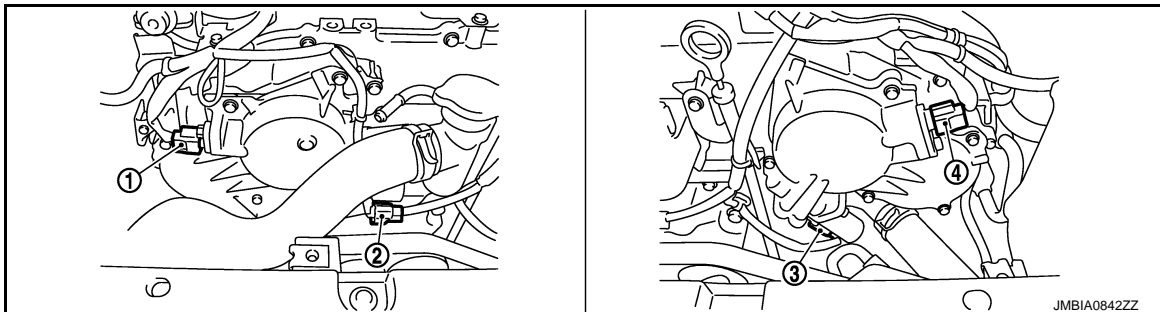

1. Camshaft position sensor (PHASE) (bank 1)
2. Intake valve timing control solenoid valve (bank 1) harness connector
3. Intake valve timing control solenoid valve (bank 2) harness connector
4. Camshaft position sensor (PHASE) (bank 2)

MULTIPOINT FUEL INJECTION SYSTEM

< SYSTEM DESCRIPTION >

[VQ37VHR]

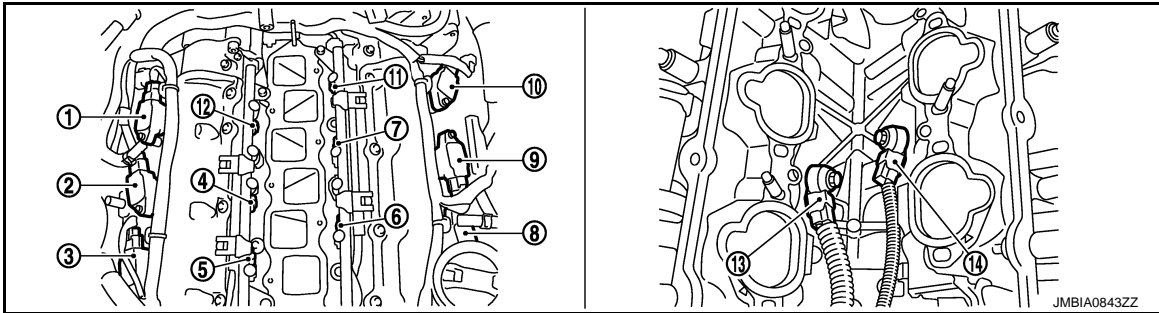

- | | | |
|--|---|---|
| 1. Ignition coil No.5 (with power transistor) | 2. Ignition coil No.3 (with power transistor) | 3. Ignition coil No.1 (with power transistor) |
| 4. Fuel injector No.3 | 5. Fuel injector No.1 | 6. Fuel injector No.2 |
| 7. Fuel injector No.4 | 8. Ignition coil No.2 (with power transistor) | 9. Ignition coil No.4 (with power transistor) |
| 10. Ignition coil No.6 (with power transistor) | 11. Fuel injector No.6 | 12. Fuel injector No.5 |
| 13. Knock sensor (bank 1) | 14. Knock sensor (bank 2) | |

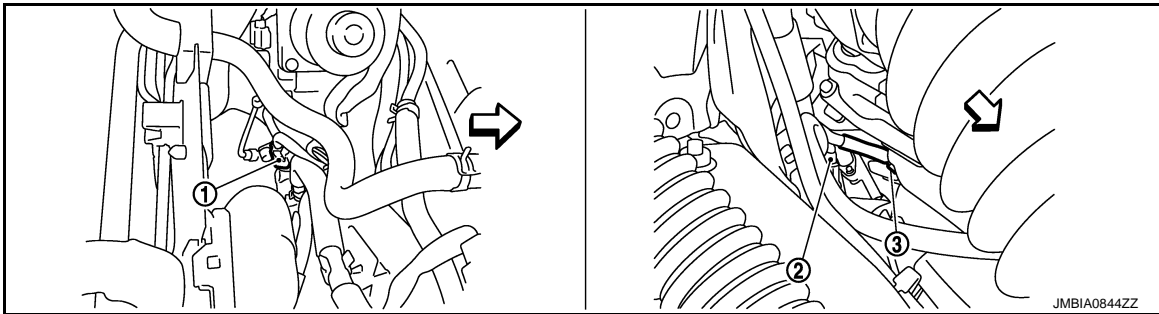

↔ : Vehicle front

- | | | |
|--------------------------------------|--------------------------|-------------------------------------|
| 1. Engine coolant temperature sensor | 2. A/F sensor 1 (bank 1) | 3. Crankshaft position sensor (POS) |
|--------------------------------------|--------------------------|-------------------------------------|

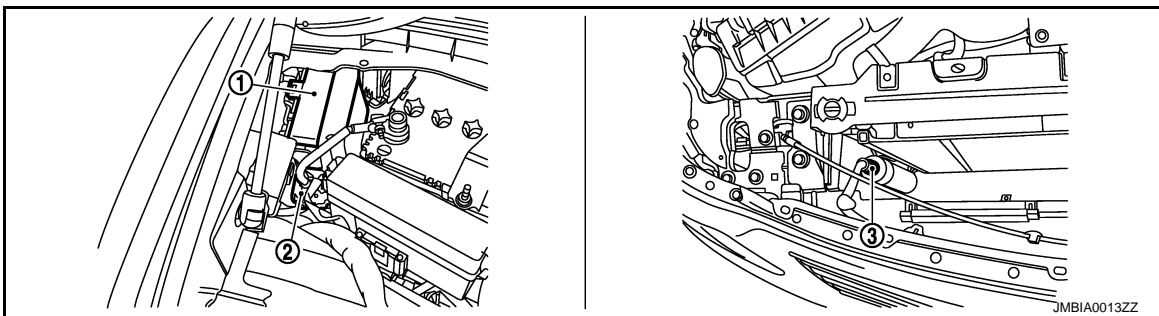

- | | | |
|-------------|---------------------------|--------------------------------|
| 1. IPDM E/R | 2. Battery current sensor | 3. Refrigerant pressure sensor |
|-------------|---------------------------|--------------------------------|

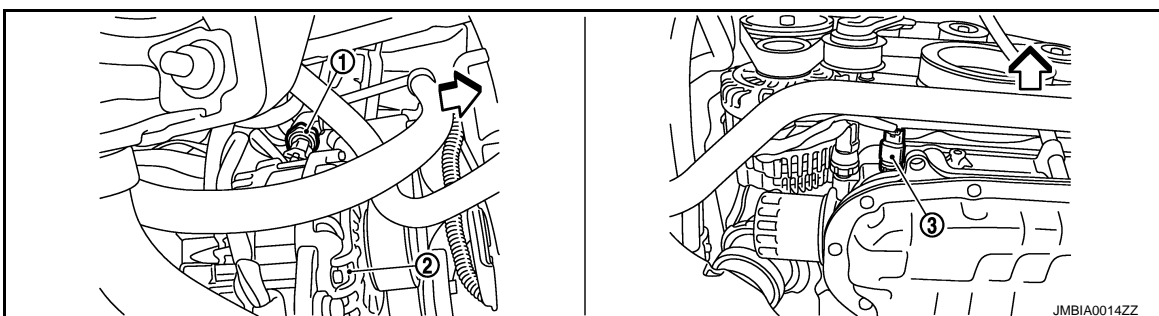

A
EC
C
D
E
F
G
H
I
J
K
L
M
N
O
P

MULTIPOINT FUEL INJECTION SYSTEM

[VQ37VHR]

< SYSTEM DESCRIPTION >

↶ : Vehicle front

1. Power steering pressure sensor 2. Alternator 3. Engine oil temperature sensor

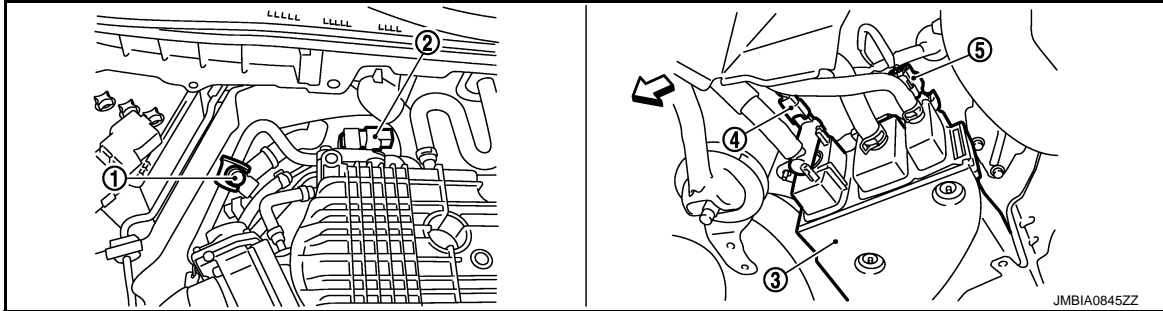

↶ : Vehicle front

1. EVAP service port 2. EVAP canister purge volume control 3. EVAP canister solenoid valve
4. EVAP canister vent control valve 5. EVAP control system pressure sensor

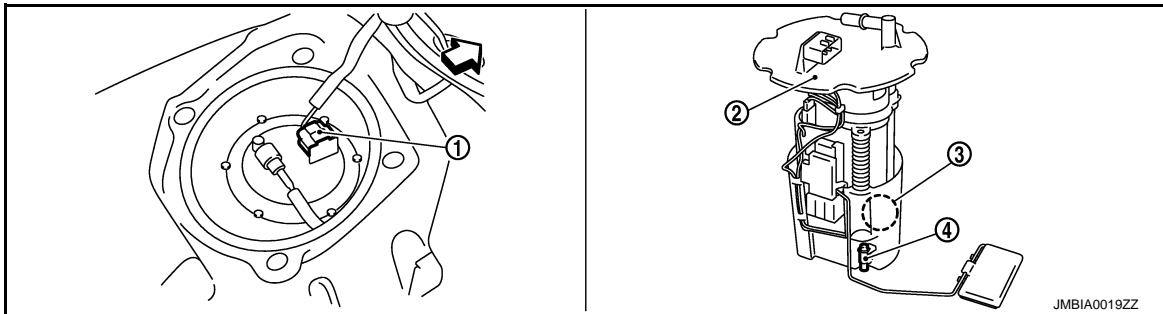

↶ : Vehicle front

1. Fuel level sensor unit and fuel pump 2. Fuel level sensor unit and fuel pump 3. Fuel pressure regulator harness connector
4. Fuel tank temperature sensor

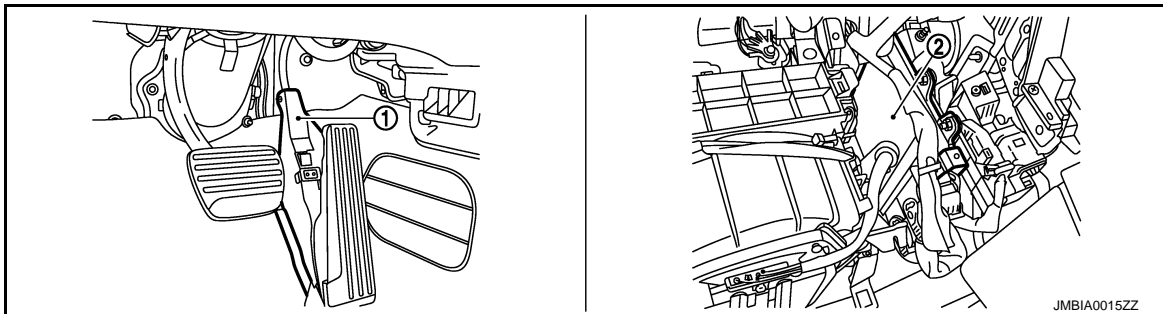

1. Accelerator pedal position sensor 2. ECM

MULTIPOINT FUEL INJECTION SYSTEM

< SYSTEM DESCRIPTION >

[VQ37VHR]

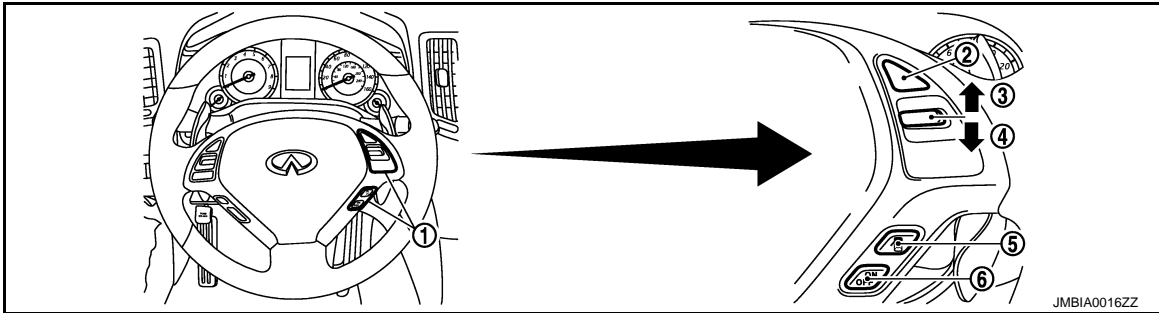

- | | | |
|------------------------|--------------------|-----------------------------|
| 1. ICC steering switch | 2. CANCEL switch | 3. RESUME/ACCELERATE switch |
| 4. SET/COAST switch | 5. DISTANCE switch | 6. MAIN switch |

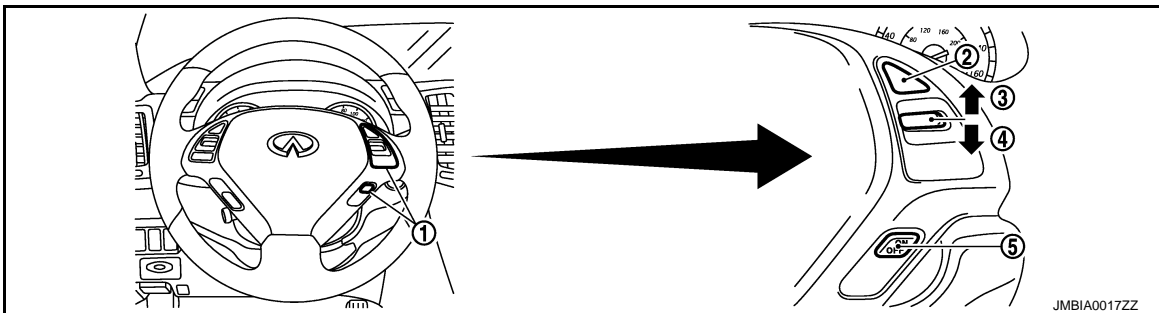

- | | | |
|-------------------------|------------------|-----------------------------|
| 1. ASCD steering switch | 2. CANCEL switch | 3. RESUME/ACCELERATE switch |
| 4. SET/COAST switch | 5. MAIN switch | |

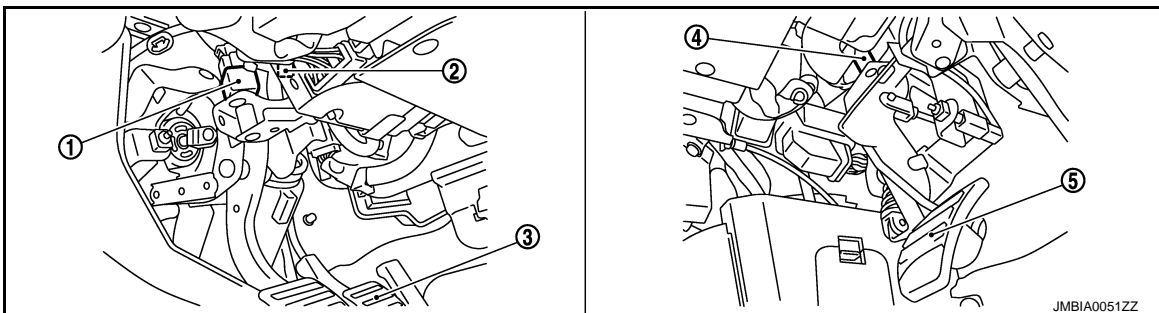

- | | | |
|---|---|----------------|
| 1. Stop lamp switch | 2. ASCD brake switch (ASCD models)
ICC brake switch (ICC models) | 3. Brake pedal |
| 4. ASCD clutch switch (ASCD models)
ICC clutch switch (ICC models) | 5. Clutch pedal | |

Component Description

INFOID:000000005151649

Component	Reference
A/F sensor 1	EC-201, "Description"
Accelerator pedal position sensor	EC-463, "Description"
Camshaft position sensor (PHASE)	EC-273, "Description"
Crankshaft position sensor (POS)	EC-269, "Description"
Engine coolant temperature sensor	EC-187, "Description"
Fuel injector	EC-492, "Description"
Heated oxygen sensor 2	EC-216, "Description"

MULTIPOINT FUEL INJECTION SYSTEM

[VQ37VHR]

< SYSTEM DESCRIPTION >

Component	Reference
Intake air temperature sensor	EC-182, "Description"
Knock sensor	EC-266, "Description"
Mass air flow sensor	EC-165, "Description"
Park/neutral position switch (M/T) TCM (A/T)	EC-367, "Description"
Power steering pressure sensor	EC-351, "Description"
Throttle position sensor	EC-190, "Description"

ELECTRIC IGNITION SYSTEM

< SYSTEM DESCRIPTION >

[VQ37VHR]

ELECTRIC IGNITION SYSTEM

System Diagram

INFOID:000000005151650

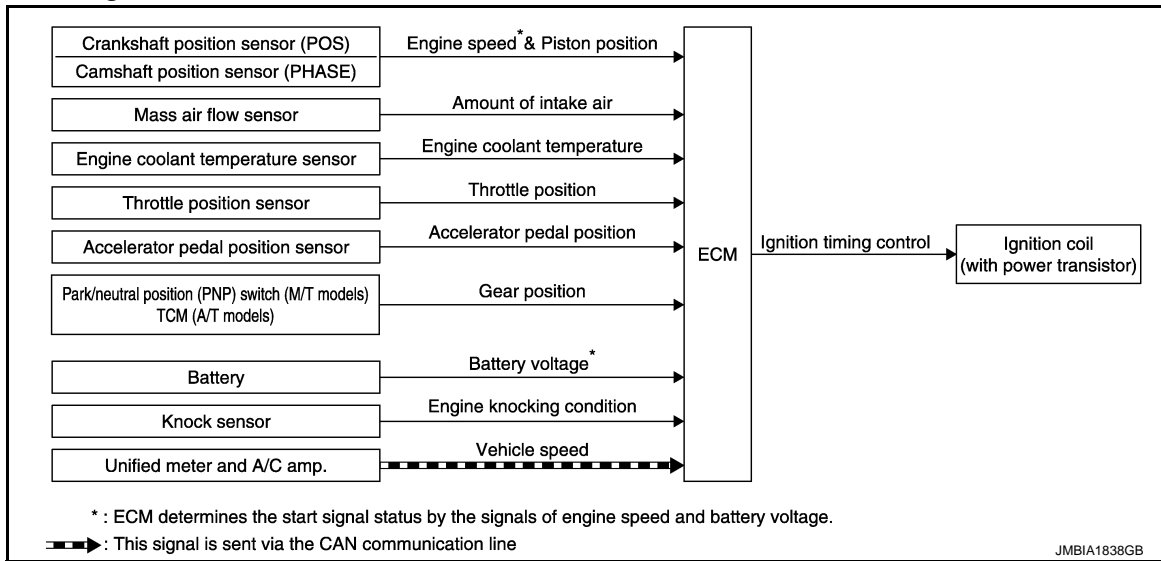

System Description

INFOID:000000005151651

INPUT/OUTPUT SIGNAL CHART

Sensor	Input Signal to ECM	ECM function	Actuator
Crankshaft position sensor (POS)	Engine speed* ² Piston position	Ignition timing control	Ignition coil (with power transistor)
Camshaft position sensor (PHASE)			
Mass air flow sensor	Amount of intake air		
Engine coolant temperature sensor	Engine coolant temperature		
Throttle position sensor	Throttle position		
Accelerator pedal position sensor	Accelerator pedal position		
Park/neutral position (PNP) switch (M/T models) TCM (A/T models)	Gear position		
Battery	Battery voltage* ²		
Knock sensor	Engine knocking		
Unified meter and A/C amp.	Vehicle speed* ¹		

*1: This signal is sent to the ECM via the CAN communication line.

*2: ECM determines the start signal status by the signals of engine speed and battery voltage.

SYSTEM DESCRIPTION

Ignition order: 1 - 2 - 3 - 4 - 5 - 6

The ignition timing is controlled by the ECM to maintain the best air-fuel ratio for every running condition of the engine. The ignition timing data is stored in the ECM.

The ECM receives information such as the injection pulse width and camshaft position sensor (PHASE) signal. Computing this information, ignition signals are transmitted to the power transistor.

During the following conditions, the ignition timing is revised by the ECM according to the other data stored in the ECM.

- At starting
- During warm-up
- At idle
- At low battery voltage
- During acceleration

The knock sensor retard system is designed only for emergencies. The basic ignition timing is programmed within the anti-knocking zone, if recommended fuel is used under dry conditions. The retard system does not

ELECTRIC IGNITION SYSTEM

[VQ37VHR]

< SYSTEM DESCRIPTION >

operate under normal driving conditions. If engine knocking occurs, the knock sensor monitors the condition. The signal is transmitted to the ECM. The ECM retards the ignition timing to eliminate the knocking condition.

Component Parts Location

INFOID:000000005151652

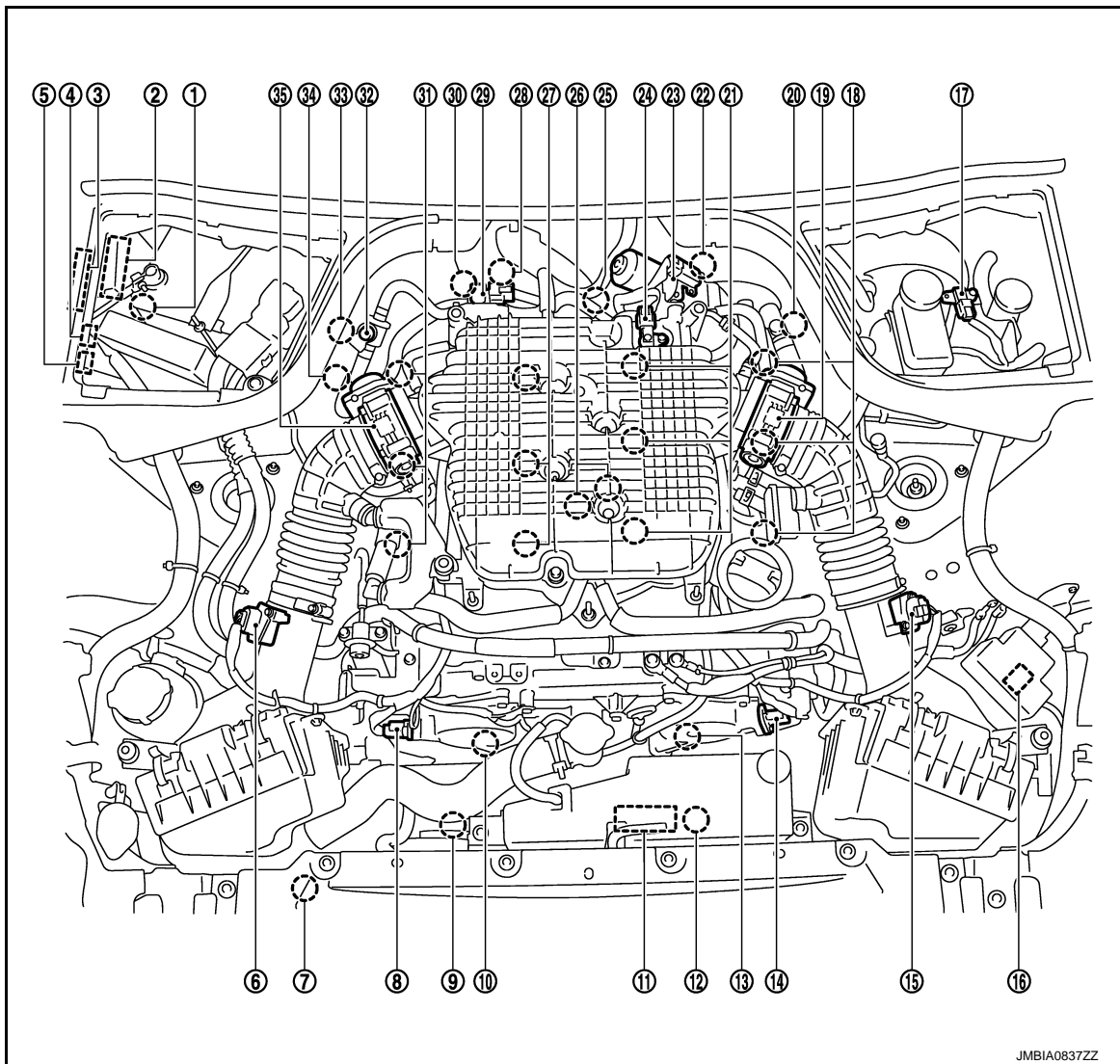

- | | | |
|---|---|---|
| 1. Battery current sensor | 2. IPDM E/R | 3. VVEL control module |
| 4. Cooling fan relay | 5. VVEL actuator motor relay | 6. Mass air flow sensor (with intake air temperature sensor) (bank 1) |
| 7. Refrigerant pressure sensor | 8. Camshaft position sensor (PHASE) (bank 1) | 9. Cooling fan motor-2 |
| 10. Intake valve timing control solenoid valve (bank 1) | 11. Cooling fan control module | 12. Cooling fan motor-1 |
| 13. Intake valve timing control solenoid valve (bank 2) | 14. Camshaft position sensor (PHASE) (bank 2) | 15. Mass air flow sensor (bank 2) |
| 16. ICC brake hold relay (ICC models) | 17. Brake booster pressure sensor | 18. Ignition coil (with power transistor) and spark plug (bank 2) |
| 19. Electric throttle control actuator (bank 2) | 20. A/F sensor 1 (bank 2) | 21. Fuel injector (bank 2) |
| 22. VVEL control shaft position sensor (bank 2) | 23. VVEL actuator motor (bank 2) | 24. Manifold absolute pressure (MAP) sensor |
| 25. Engine coolant temperature sensor | 26. Knock sensor | 27. Fuel injector (bank 1) |
| 28. VVEL actuator motor (bank 1) | 29. EVAP canister purge volume control solenoid valve | 30. VVEL control shaft position sensor (bank 1) |

ELECTRIC IGNITION SYSTEM

[VQ37VHR]

< SYSTEM DESCRIPTION >

- | | | |
|---|---|---------------------------|
| 31. Ignition coil (with power transistor and spark plug (bank 1)) | 32. EVAP service port | 33. A/F sensor 1 (bank 1) |
| 34. Crankshaft position sensor (POS) | 35. Electric throttle control actuator (bank 1) | |

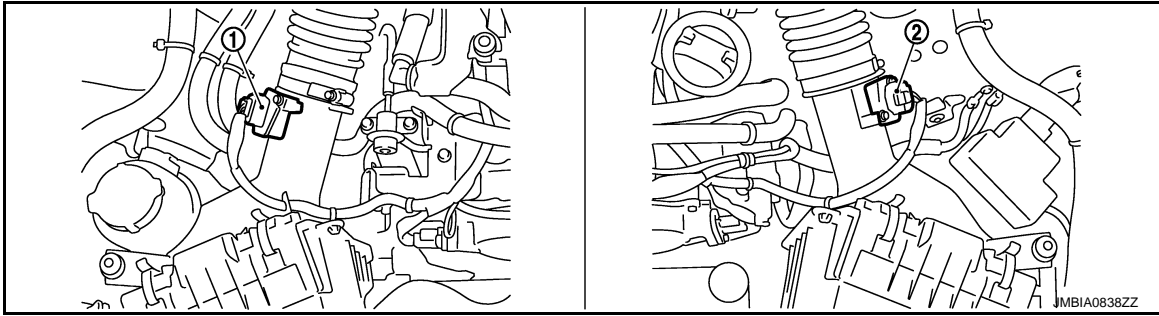

- | | |
|---|----------------------------------|
| 1. Mass air flow sensor (with intake air temperature sensor) (bank 1) | 2. Mass air flow sensor (bank 2) |
|---|----------------------------------|

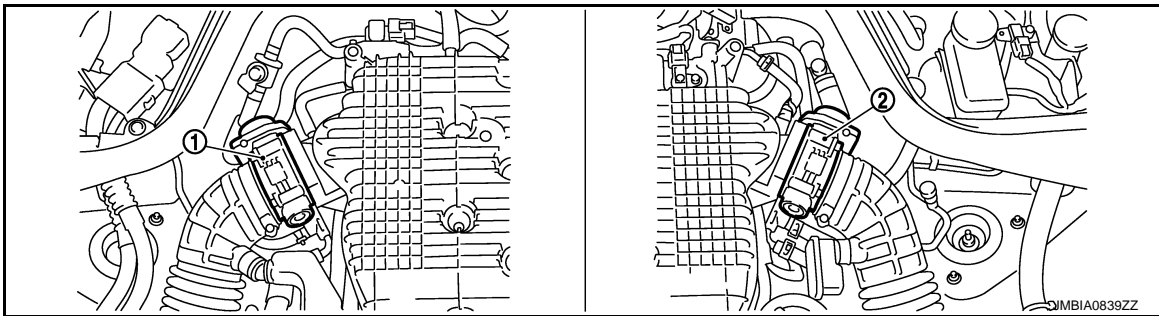

- | | |
|--|--|
| 1. Electric throttle control actuator (bank 1) | 2. Electric throttle control actuator (bank 2) |
|--|--|

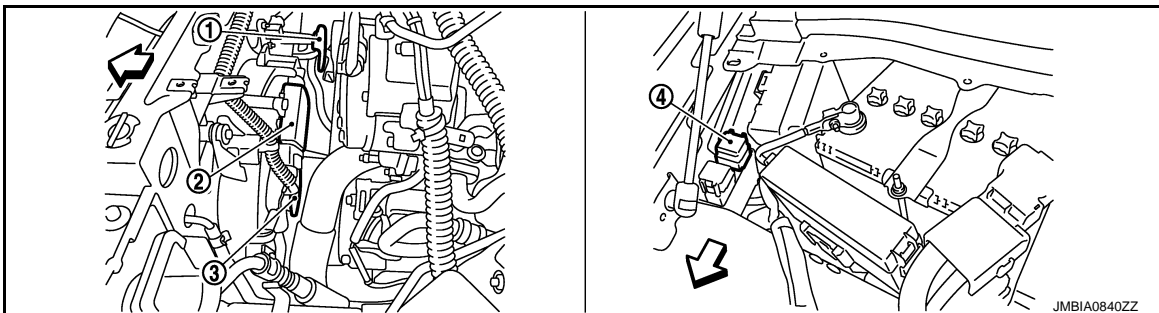

↔ : Vehicle front

- | | | |
|------------------------|-------------------------------|------------------------|
| 1. Cooling fan motor-2 | 2. Cooling fan control module | 3. Cooling fan motor-1 |
| 4. Cooling fan relay | | |

A
EC
C
D
E
F
G
H
I
J
K
L
M
N
O
P

ELECTRIC IGNITION SYSTEM

< SYSTEM DESCRIPTION >

[VQ37VHR]

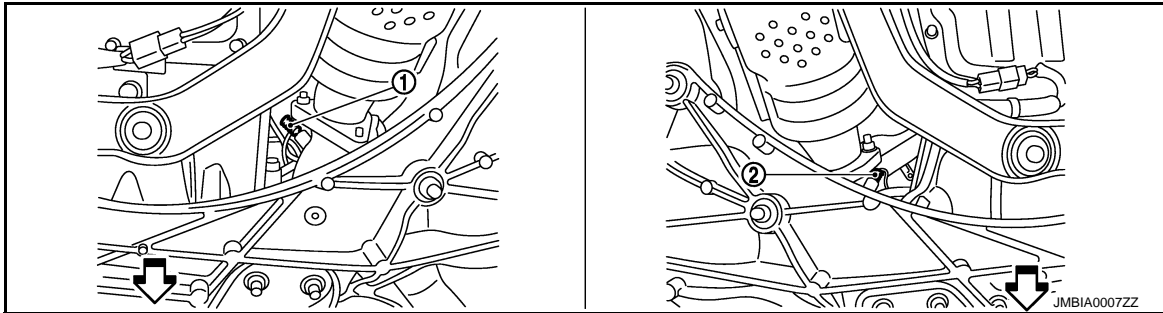
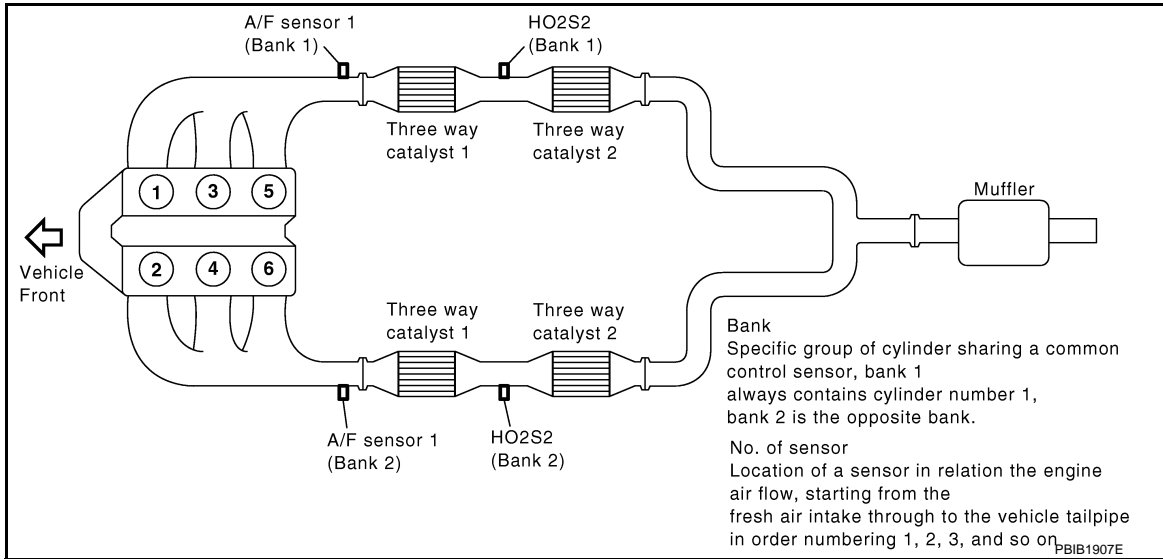

← : Vehicle front

1. A/F sensor 1 (bank 1)
2. A/F sensor 1 (bank 2)

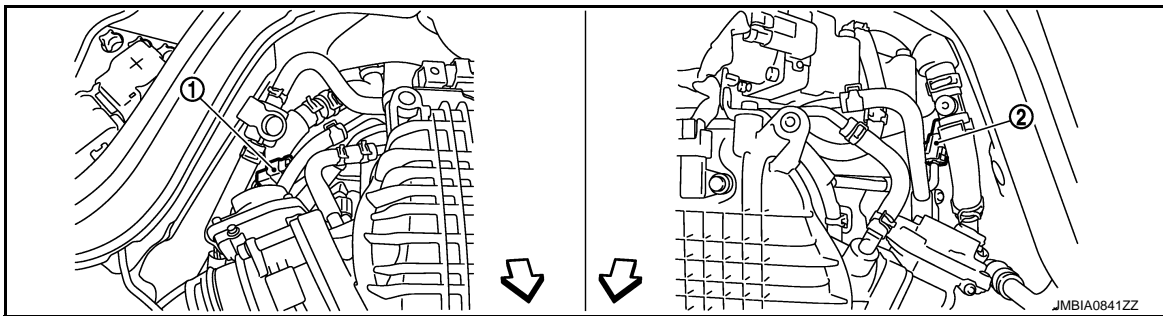

← : Vehicle front

1. A/F sensor 1 (bank 1) harness connector
2. A/F sensor 1 (bank 2) harness connector

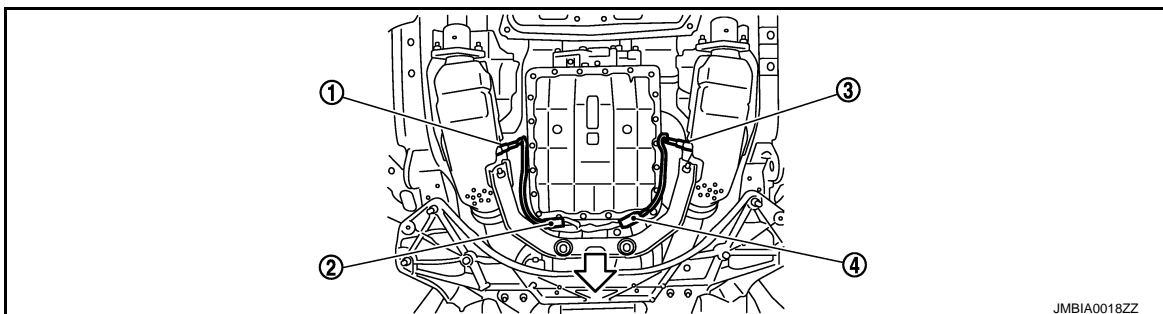

ELECTRIC IGNITION SYSTEM

[VQ37VHR]

< SYSTEM DESCRIPTION >

↩: Vehicle front

1. Heated oxygen sensor 2 (bank 2)
2. Heated oxygen sensor 2 (bank 2) harness connector
3. Heated oxygen sensor 2 (bank 1)
4. Heated oxygen sensor 2 (bank 1) harness connector

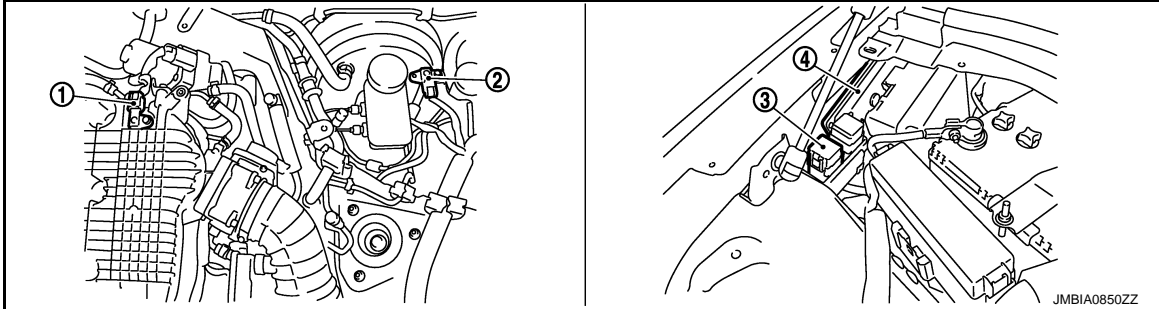

1. Manifold absolute pressure (MAP) sensor
2. Brake booster pressure sensor
3. VVEL actuator motor relay
4. VVEL control module



↩: Vehicle front

1. VVEL control shaft position sensor (bank 1)
2. VVEL actuator motor (bank 1)
3. VVEL actuator motor (bank 2)
4. VVEL control shaft position sensor (bank 2)

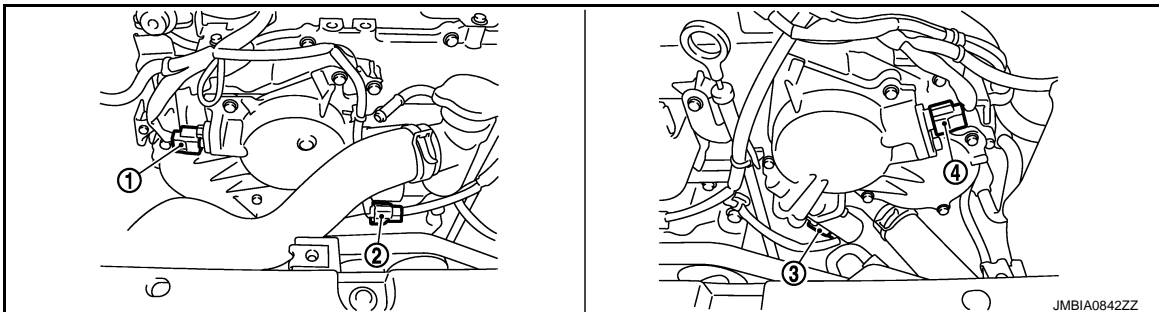

1. Camshaft position sensor (PHASE) (bank 1)
2. Intake valve timing control solenoid valve (bank 1) harness connector
3. Intake valve timing control solenoid valve (bank 2) harness connector
4. Camshaft position sensor (PHASE) (bank 2)

A
EC
C
D
E
F
G
H
I
J
K
L
M
N
O
P

ELECTRIC IGNITION SYSTEM

< SYSTEM DESCRIPTION >

[VQ37VHR]

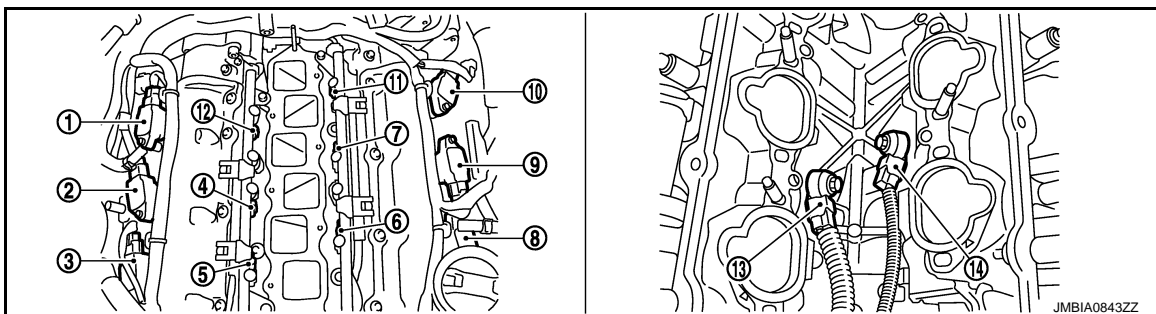

- | | | |
|--|---|---|
| 1. Ignition coil No.5 (with power transistor) | 2. Ignition coil No.3 (with power transistor) | 3. Ignition coil No.1 (with power transistor) |
| 4. Fuel injector No.3 | 5. Fuel injector No.1 | 6. Fuel injector No.2 |
| 7. Fuel injector No.4 | 8. Ignition coil No.2 (with power transistor) | 9. Ignition coil No.4 (with power transistor) |
| 10. Ignition coil No.6 (with power transistor) | 11. Fuel injector No.6 | 12. Fuel injector No.5 |
| 13. Knock sensor (bank 1) | 14. Knock sensor (bank 2) | |

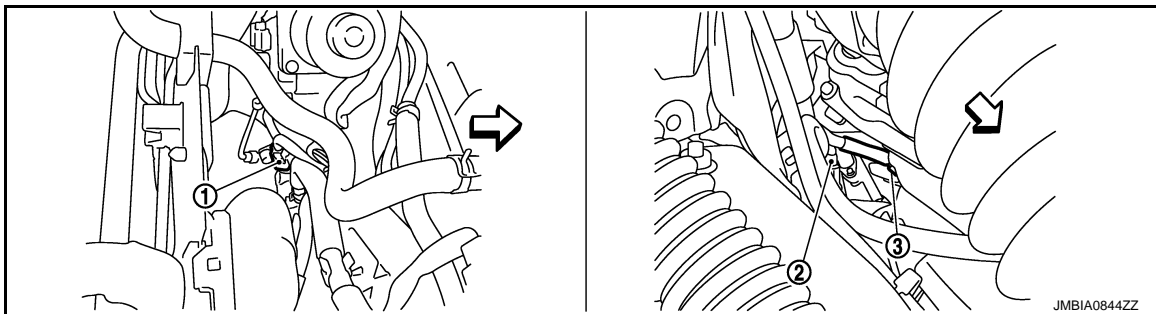

↶ : Vehicle front

- | | | |
|--------------------------------------|--------------------------|-------------------------------------|
| 1. Engine coolant temperature sensor | 2. A/F sensor 1 (bank 1) | 3. Crankshaft position sensor (POS) |
|--------------------------------------|--------------------------|-------------------------------------|

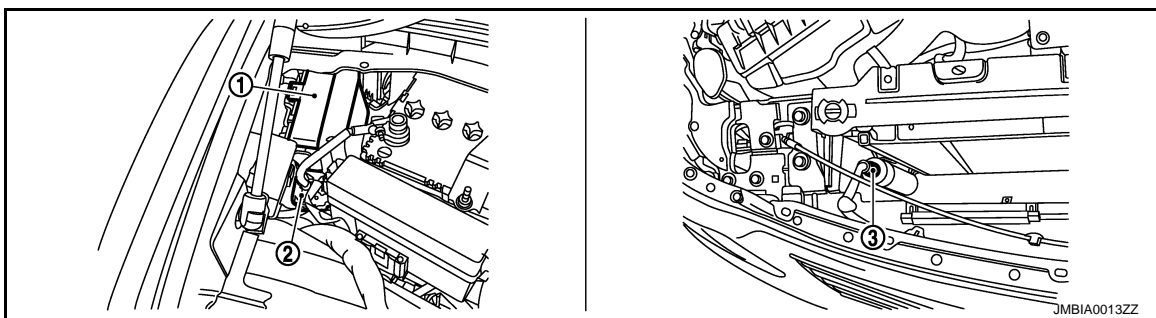

- | | | |
|-------------|---------------------------|--------------------------------|
| 1. IPDM E/R | 2. Battery current sensor | 3. Refrigerant pressure sensor |
|-------------|---------------------------|--------------------------------|

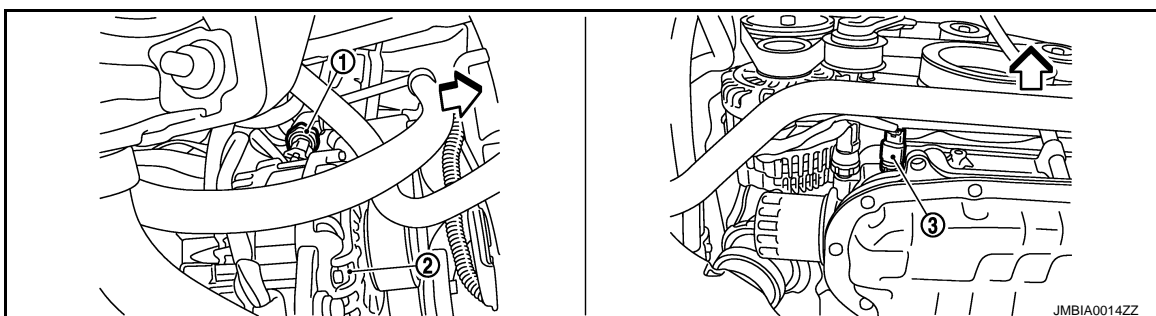

ELECTRIC IGNITION SYSTEM

[VQ37VHR]

< SYSTEM DESCRIPTION >

↖: Vehicle front

1. Power steering pressure sensor 2. Alternator 3. Engine oil temperature sensor

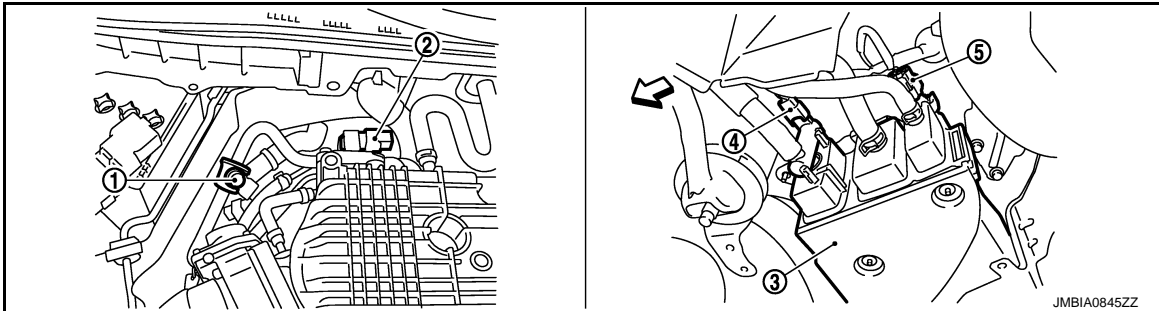

↖: Vehicle front

1. EVAP service port 2. EVAP canister purge volume control 3. EVAP canister solenoid valve
 4. EVAP canister vent control valve 5. EVAP control system pressure sensor

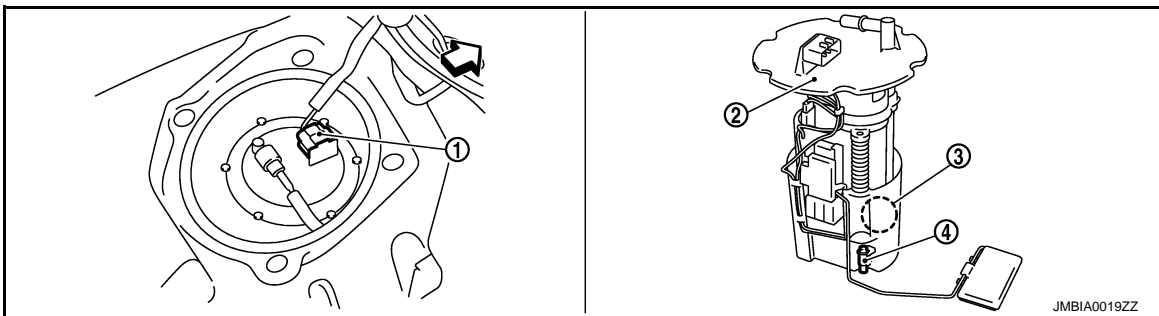

↖: Vehicle front

1. Fuel level sensor unit and fuel pump harness connector 2. Fuel level sensor unit and fuel pump 3. Fuel pressure regulator
 4. Fuel tank temperature sensor

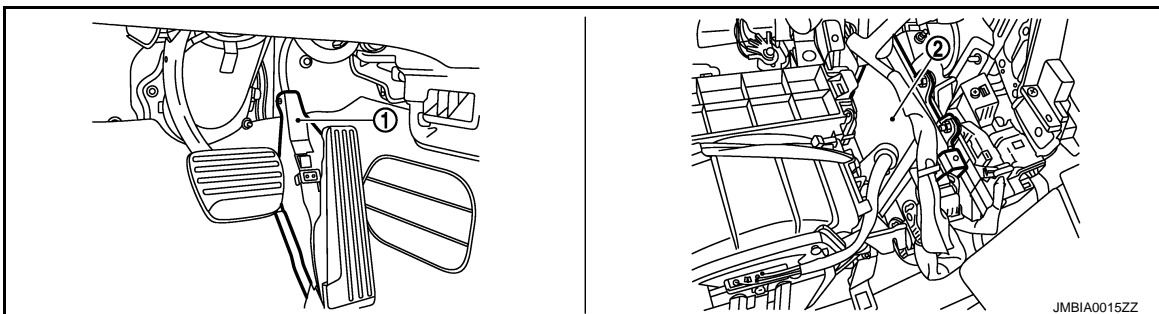

1. Accelerator pedal position sensor 2. ECM

A
 EC
 C
 D
 E
 F
 G
 H
 I
 J
 K
 L
 M
 N
 O
 P

ELECTRIC IGNITION SYSTEM

< SYSTEM DESCRIPTION >

[VQ37VHR]

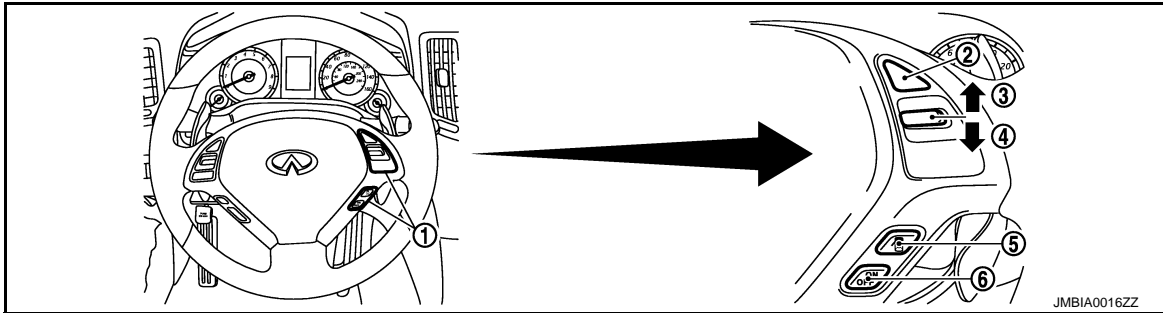

- 1. ICC steering switch
- 2. CANCEL switch
- 3. RESUME/ACCELERATE switch
- 4. SET/COAST switch
- 5. DISTANCE switch
- 6. MAIN switch

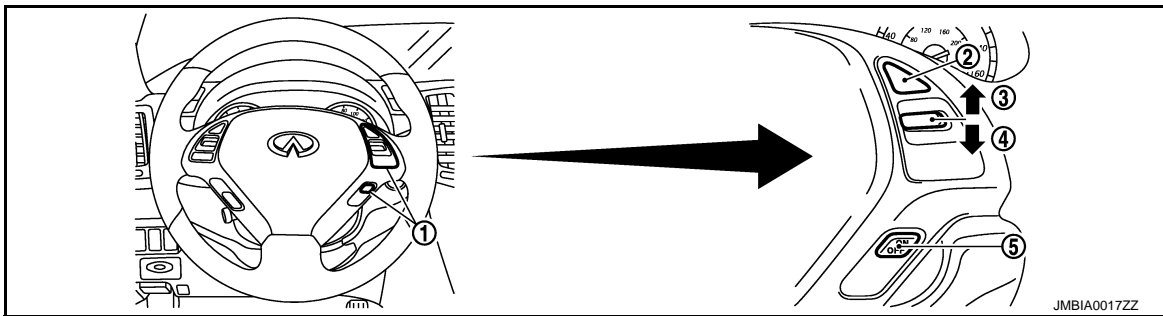

- 1. ASCD steering switch
- 2. CANCEL switch
- 3. RESUME/ACCELERATE switch
- 4. SET/COAST switch
- 5. MAIN switch

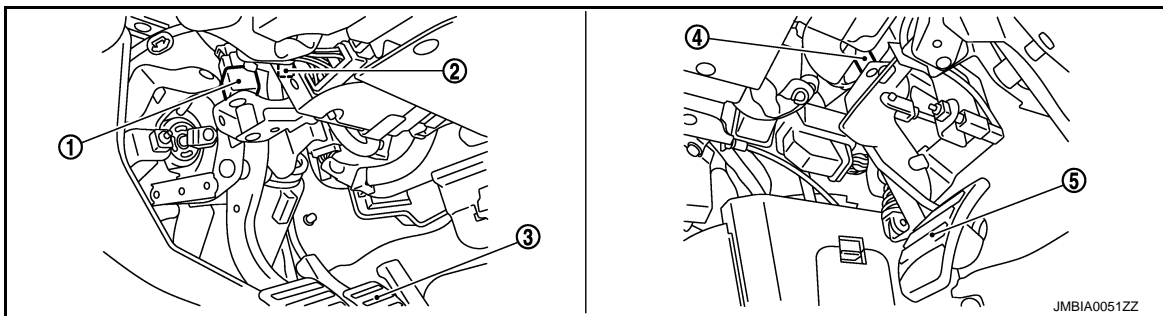

- 1. Stop lamp switch
- 2. ASCD brake switch (ASCD models) / ICC brake switch (ICC models)
- 3. Brake pedal
- 4. ASCD clutch switch (ASCD models) / ICC clutch switch (ICC models)
- 5. Clutch pedal

Component Description

INFOID:000000005151653

Component	Reference
Accelerator pedal position sensor	EC-463. "Description"
Camshaft position sensor (PHASE)	EC-273. "Description"
Crankshaft position sensor (POS)	EC-269. "Description"
Engine coolant temperature sensor	EC-187. "Description"
Ignition signal	EC-503. "Description"
Knock sensor	EC-266. "Description"
Mass air flow sensor	EC-165. "Description"

ELECTRIC IGNITION SYSTEM

< SYSTEM DESCRIPTION >

[VQ37VHR]

Component	Reference
Park/neutral position switch (M/T) TCM (A/T)	EC-367, "Description"
Throttle position sensor	EC-190, "Description"

A

EC

C

D

E

F

G

H

I

J

K

L

M

N

O

P

AIR CONDITIONING CUT CONTROL

< SYSTEM DESCRIPTION >

[VQ37VHR]

AIR CONDITIONING CUT CONTROL

System Diagram

INFOID:000000005151654

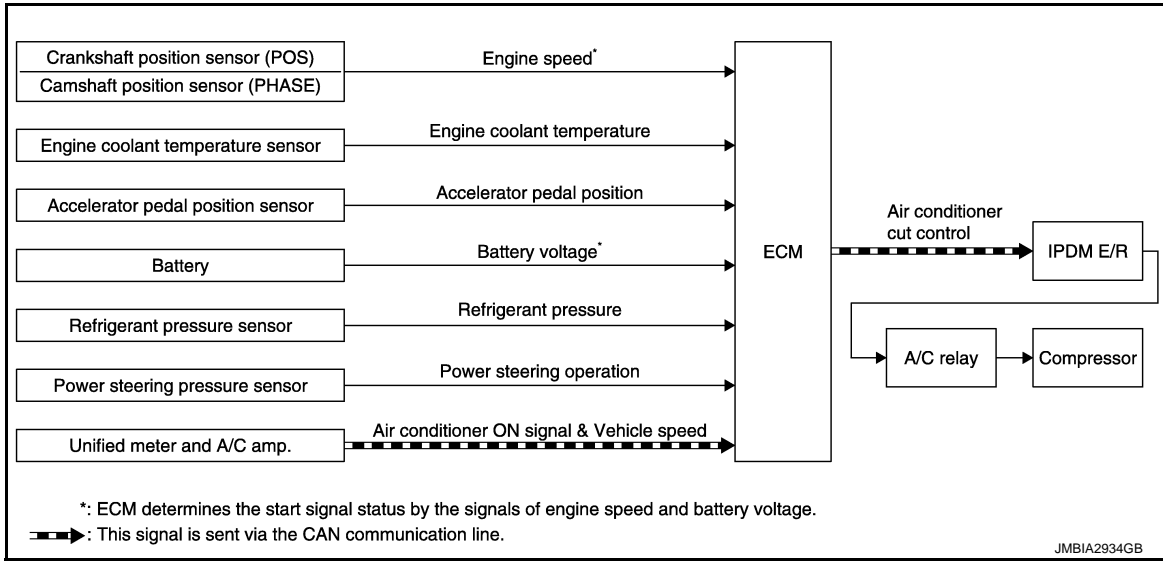

System Description

INFOID:000000005151655

INPUT/OUTPUT SIGNAL CHART

Sensor	Input Signal to ECM	ECM function	Actuator
Crankshaft position sensor (POS) Camshaft position sensor (PHASE)	Engine speed*2	Air conditioner cut control	IPDM E/R ↓ A/C relay ↓ Compressor
Engine coolant temperature sensor	Engine coolant temperature		
Accelerator pedal position sensor	Accelerator pedal position		
Battery	Battery voltage*2		
Refrigerant pressure sensor	Refrigerant pressure		
Power steering pressure sensor	Power steering operation		
Unified meter and A/C amp.	Air conditioner ON signal*1		
	Vehicle speed*1		

*1: This signal is sent to the ECM via the CAN communication line.

*2: ECM determines the start signal status by the signals of engine speed and battery voltage.

SYSTEM DESCRIPTION

This system improves engine operation when the air conditioner is used. Under the following conditions, the air conditioner is turned off.

- When the accelerator pedal is fully depressed
- When cranking the engine
- At high engine speeds
- When the engine coolant temperature becomes excessively high
- When operating power steering during low engine speed or low vehicle speed
- When engine speed is excessively low
- When refrigerant pressure is excessively low or high

AIR CONDITIONING CUT CONTROL

< SYSTEM DESCRIPTION >

[VQ37VHR]

Component Parts Location

INFOID:000000005151656

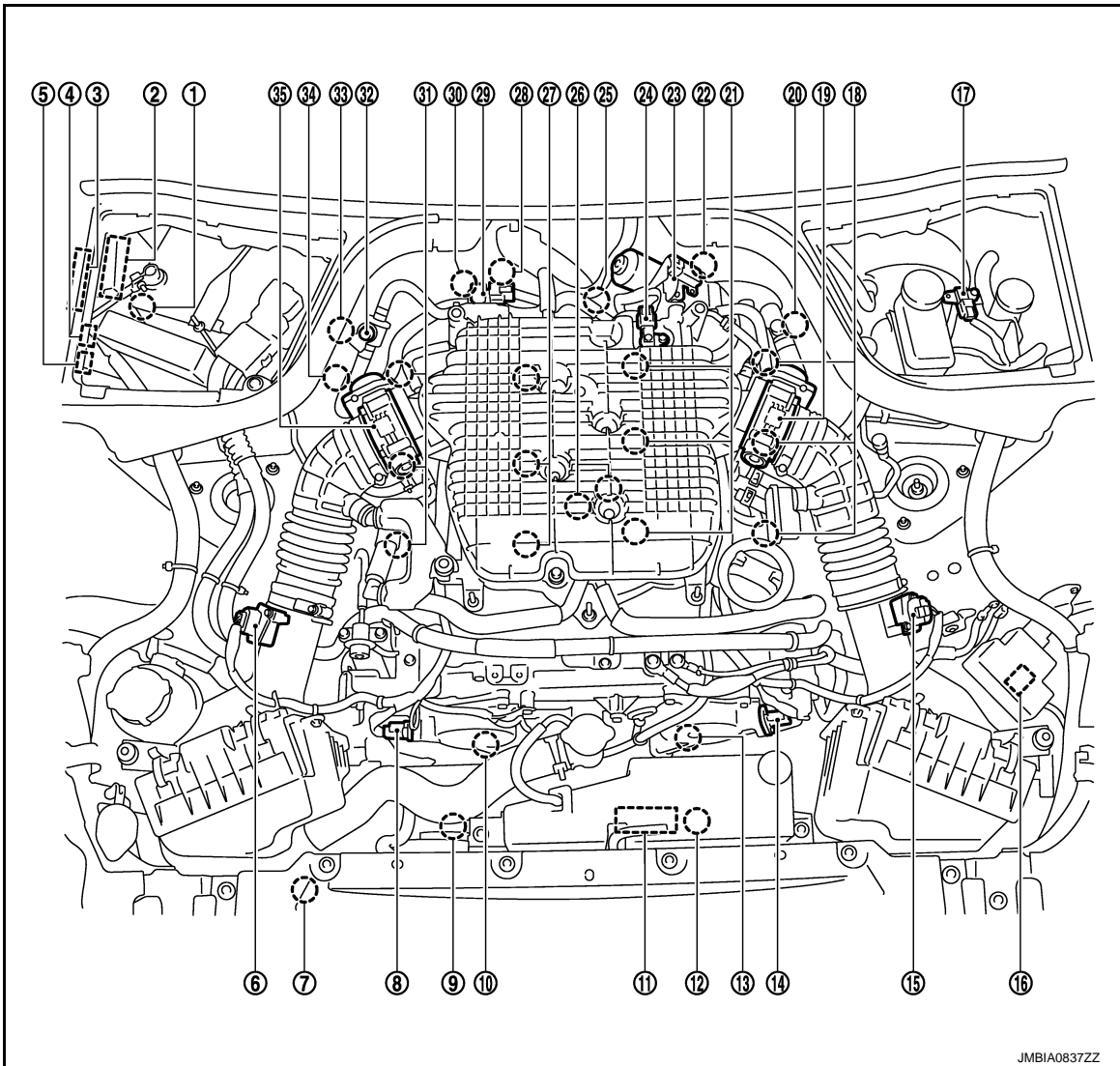

- | | | |
|---|---|---|
| 1. Battery current sensor | 2. IPDM E/R | 3. VVEL control module |
| 4. Cooling fan relay | 5. VVEL actuator motor relay | 6. Mass air flow sensor (with intake air temperature sensor) (bank 1) |
| 7. Refrigerant pressure sensor | 8. Camshaft position sensor (PHASE) (bank 1) | 9. Cooling fan motor-2 |
| 10. Intake valve timing control solenoid valve (bank 1) | 11. Cooling fan control module | 12. Cooling fan motor-1 |
| 13. Intake valve timing control solenoid valve (bank 2) | 14. Camshaft position sensor (PHASE) (bank 2) | 15. Mass air flow sensor (bank 2) |
| 16. ICC brake hold relay (ICC models) | 17. Brake booster pressure sensor | 18. Ignition coil (with power transistor and spark plug) (bank 2) |
| 19. Electric throttle control actuator (bank 2) | 20. A/F sensor 1 (bank 2) | 21. Fuel injector (bank 2) |
| 22. VVEL control shaft position sensor (bank 2) | 23. VVEL actuator motor (bank 2) | 24. Manifold absolute pressure (MAP) sensor |
| 25. Engine coolant temperature sensor | 26. Knock sensor | 27. Fuel injector (bank 1) |
| 28. VVEL actuator motor (bank 1) | 29. EVAP canister purge volume control solenoid valve | 30. VVEL control shaft position sensor (bank 1) |

AIR CONDITIONING CUT CONTROL

[VQ37VHR]

< SYSTEM DESCRIPTION >

- | | | |
|---|---|---------------------------|
| 31. Ignition coil (with power transistor and spark plug (bank 1)) | 32. EVAP service port | 33. A/F sensor 1 (bank 1) |
| 34. Crankshaft position sensor (POS) | 35. Electric throttle control actuator (bank 1) | |

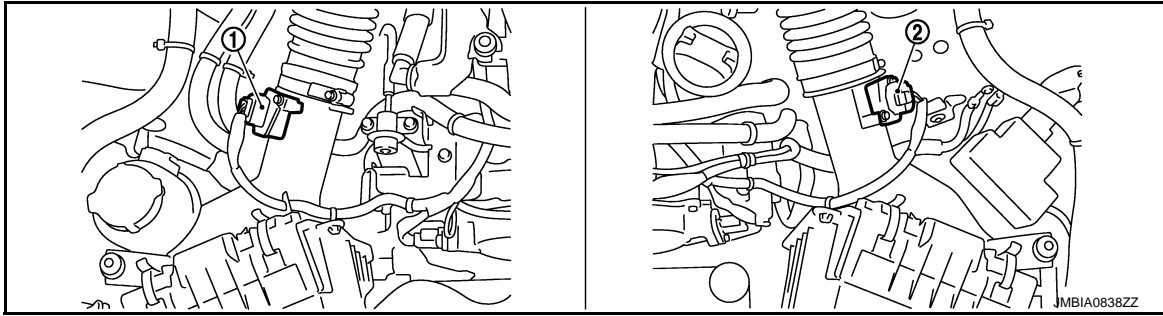

- | | |
|---|----------------------------------|
| 1. Mass air flow sensor (with intake air temperature sensor) (bank 1) | 2. Mass air flow sensor (bank 2) |
|---|----------------------------------|

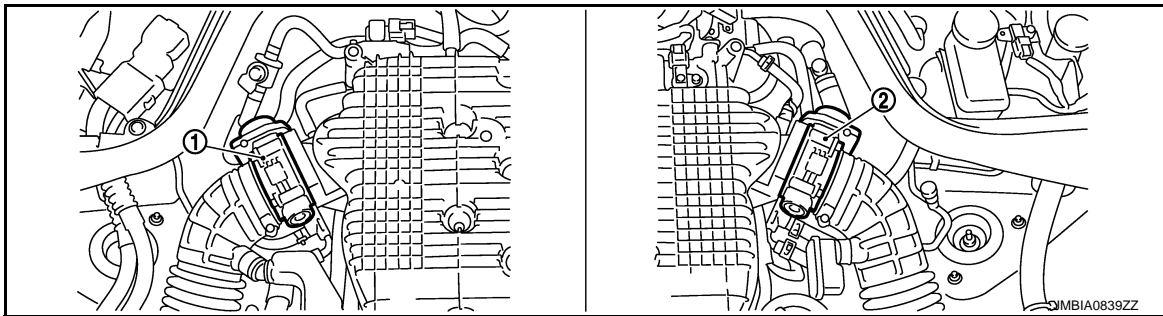

- | | |
|--|--|
| 1. Electric throttle control actuator (bank 1) | 2. Electric throttle control actuator (bank 2) |
|--|--|

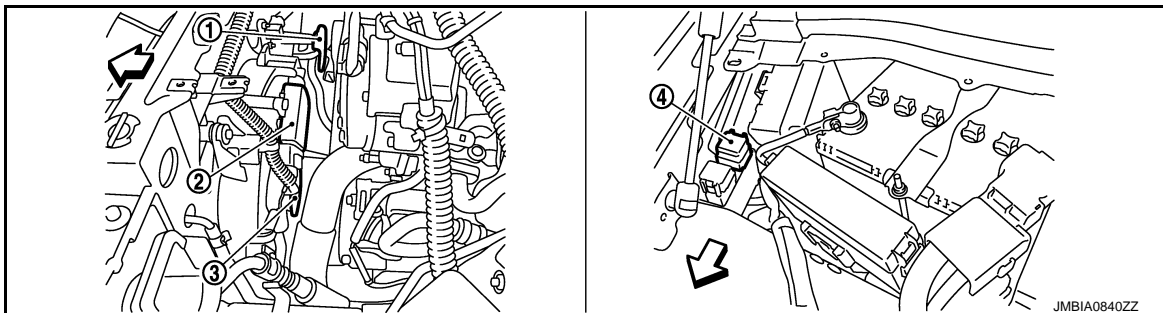

↙ : Vehicle front

- | | | |
|------------------------|-------------------------------|------------------------|
| 1. Cooling fan motor-2 | 2. Cooling fan control module | 3. Cooling fan motor-1 |
| 4. Cooling fan relay | | |

AIR CONDITIONING CUT CONTROL

< SYSTEM DESCRIPTION >

[VQ37VHR]

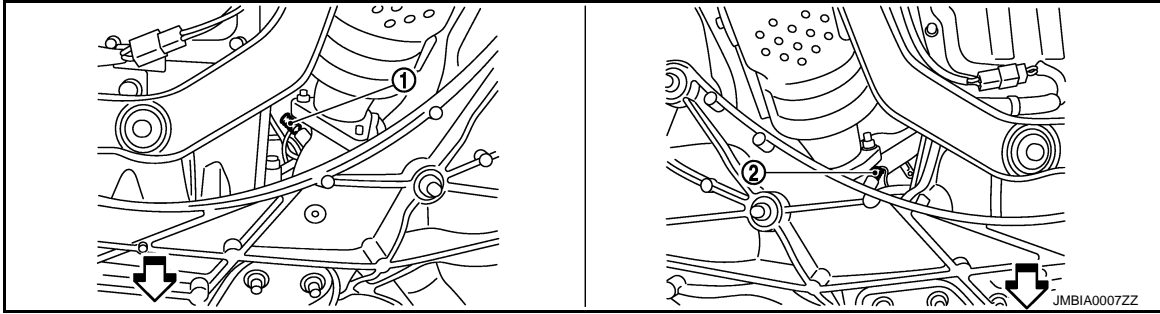
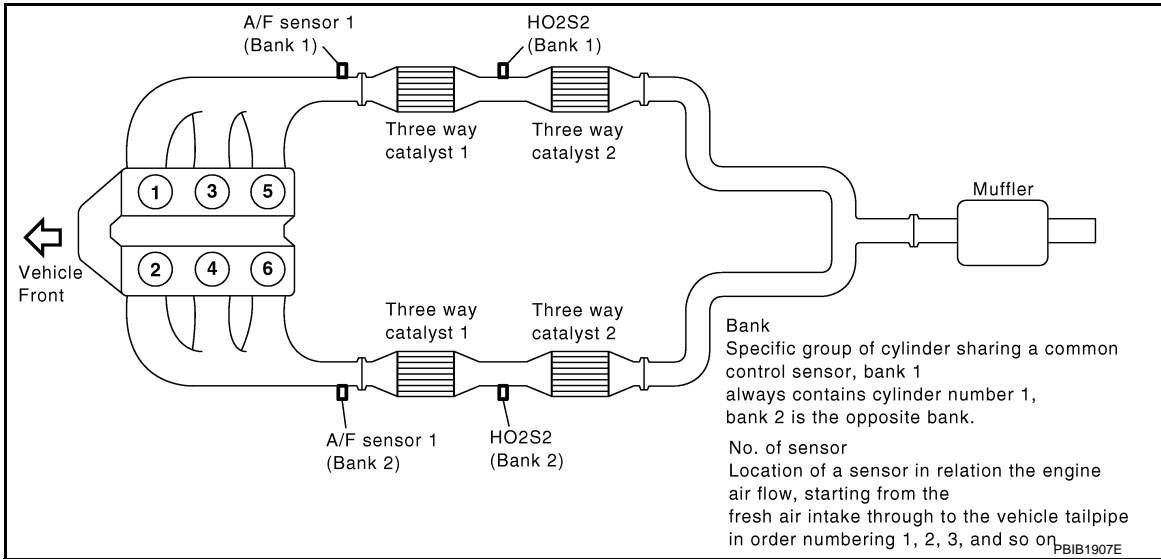

←: Vehicle front

1. A/F sensor 1 (bank 1)
2. A/F sensor 1 (bank 2)

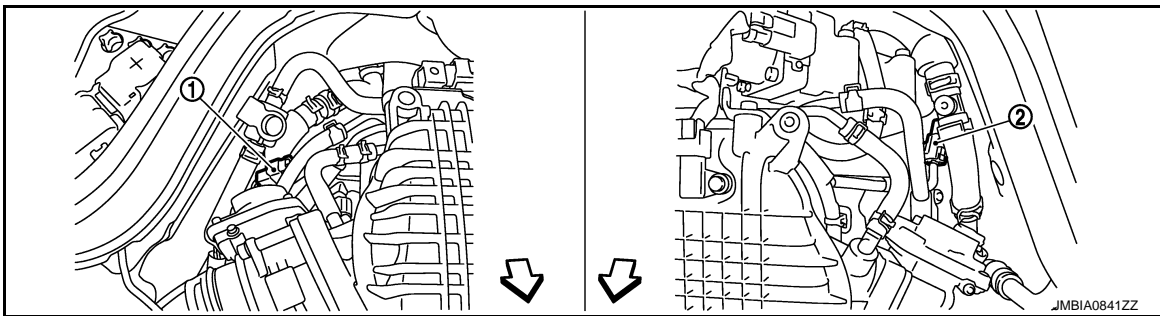

←: Vehicle front

1. A/F sensor 1 (bank 1) harness connector
2. A/F sensor 1 (bank 2) harness connector

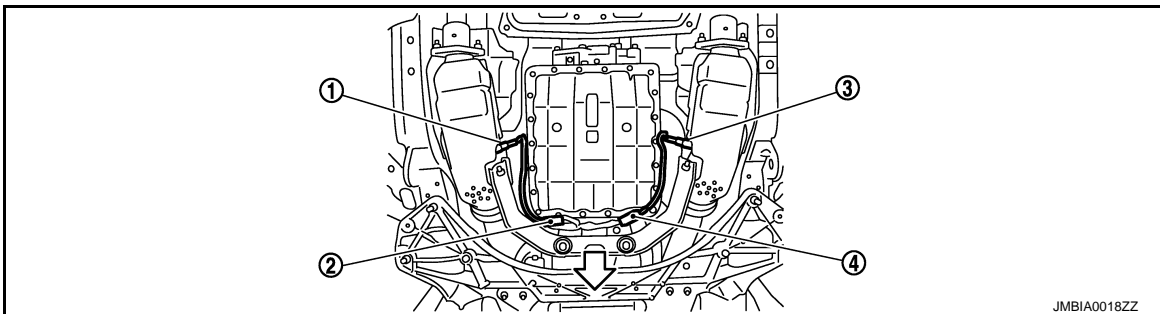

A
EC
C
D
E
F
G
H
I
J
K
L
M
N
O
P

AIR CONDITIONING CUT CONTROL

[VQ37VHR]

< SYSTEM DESCRIPTION >

↖ : Vehicle front

1. Heated oxygen sensor 2 (bank 2)
2. Heated oxygen sensor 2 (bank 2) harness connector
3. Heated oxygen sensor 2 (bank 1)
4. Heated oxygen sensor 2 (bank 1) harness connector

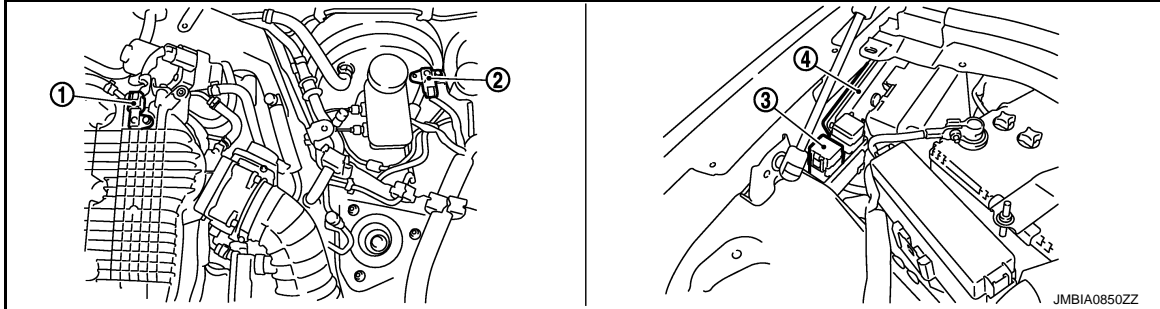

1. Manifold absolute pressure (MAP) sensor
2. Brake booster pressure sensor
3. VVEL actuator motor relay
4. VVEL control module



↖ : Vehicle front

1. VVEL control shaft position sensor (bank 1)
2. VVEL actuator motor (bank 1)
3. VVEL actuator motor (bank 2)
4. VVEL control shaft position sensor (bank 2)

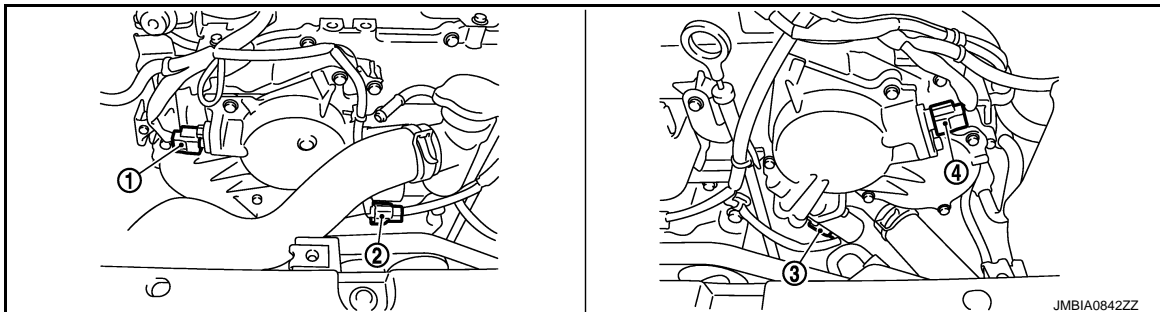

1. Camshaft position sensor (PHASE) (bank 1)
2. Intake valve timing control solenoid valve (bank 1) harness connector
3. Intake valve timing control solenoid valve (bank 2) harness connector
4. Camshaft position sensor (PHASE) (bank 2)

AIR CONDITIONING CUT CONTROL

< SYSTEM DESCRIPTION >

[VQ37VHR]

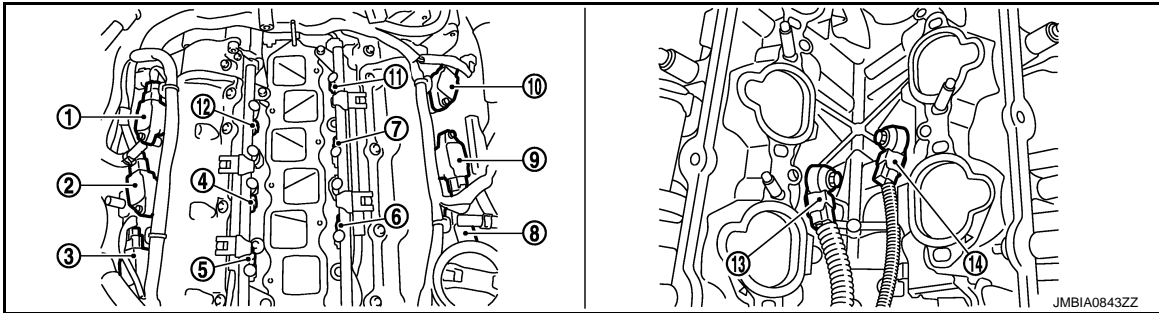

- | | | |
|--|---|---|
| 1. Ignition coil No.5 (with power transistor) | 2. Ignition coil No.3 (with power transistor) | 3. Ignition coil No.1 (with power transistor) |
| 4. Fuel injector No.3 | 5. Fuel injector No.1 | 6. Fuel injector No.2 |
| 7. Fuel injector No.4 | 8. Ignition coil No.2 (with power transistor) | 9. Ignition coil No.4 (with power transistor) |
| 10. Ignition coil No.6 (with power transistor) | 11. Fuel injector No.6 | 12. Fuel injector No.5 |
| 13. Knock sensor (bank 1) | 14. Knock sensor (bank 2) | |

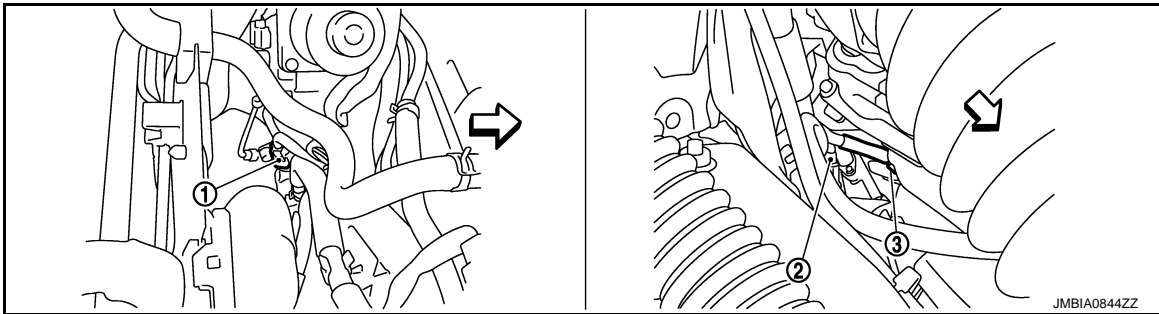

↔ : Vehicle front

- | | | |
|--------------------------------------|--------------------------|-------------------------------------|
| 1. Engine coolant temperature sensor | 2. A/F sensor 1 (bank 1) | 3. Crankshaft position sensor (POS) |
|--------------------------------------|--------------------------|-------------------------------------|

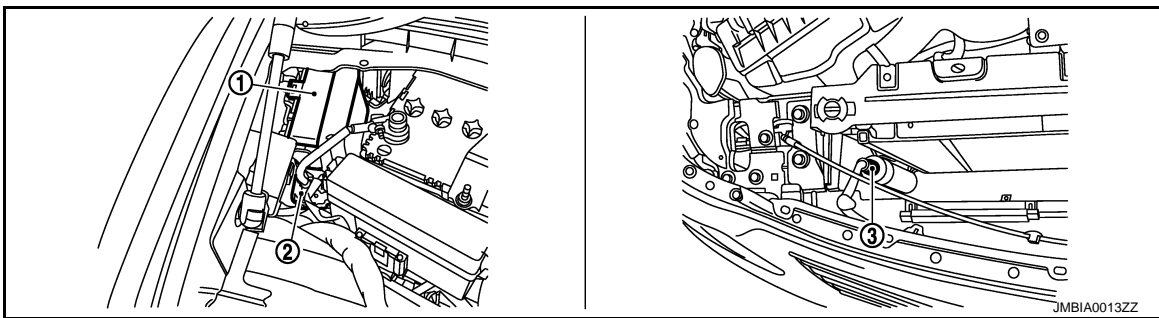

- | | | |
|-------------|---------------------------|--------------------------------|
| 1. IPDM E/R | 2. Battery current sensor | 3. Refrigerant pressure sensor |
|-------------|---------------------------|--------------------------------|

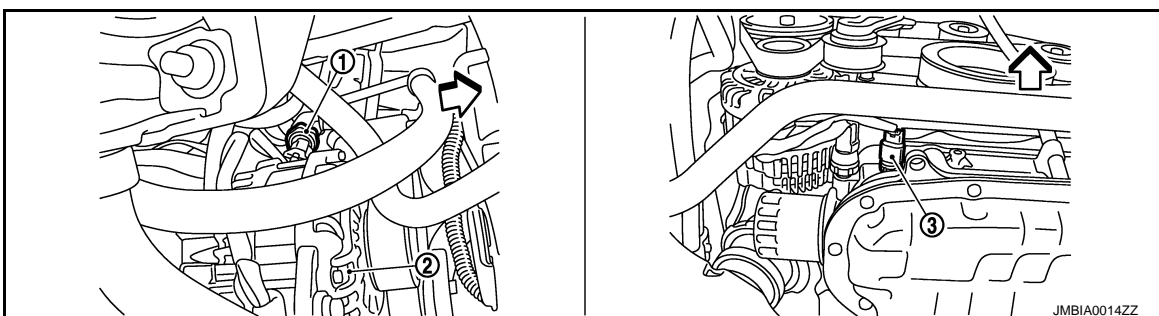

A
EC
C
D
E
F
G
H
I
J
K
L
M
N
O
P

AIR CONDITIONING CUT CONTROL

[VQ37VHR]

< SYSTEM DESCRIPTION >

↶ : Vehicle front

1. Power steering pressure sensor 2. Alternator 3. Engine oil temperature sensor

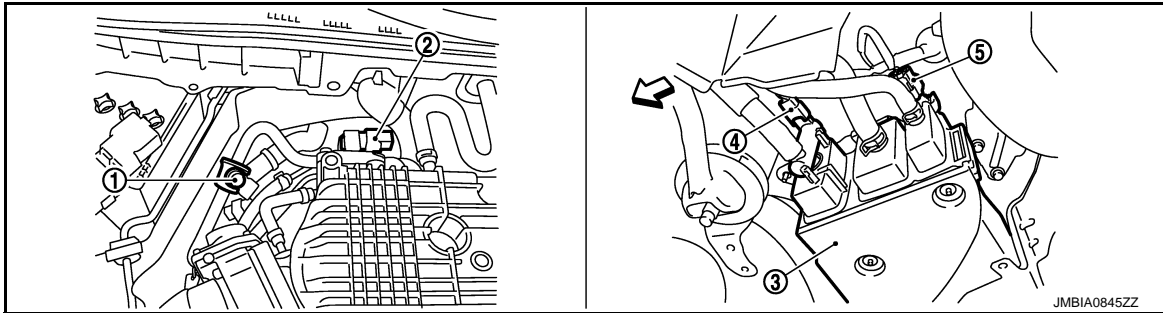

↶ : Vehicle front

1. EVAP service port 2. EVAP canister purge volume control 3. EVAP canister solenoid valve
4. EVAP canister vent control valve 5. EVAP control system pressure sensor

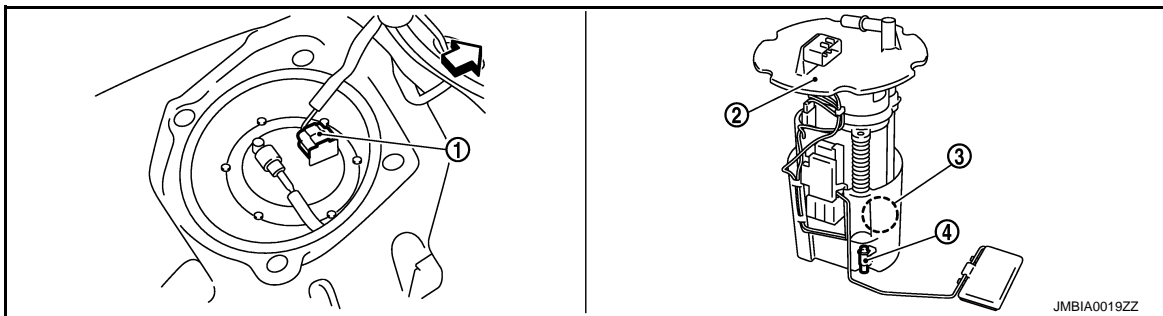

↶ : Vehicle front

1. Fuel level sensor unit and fuel pump 2. Fuel level sensor unit and fuel pump 3. Fuel pressure regulator harness connector
4. Fuel tank temperature sensor

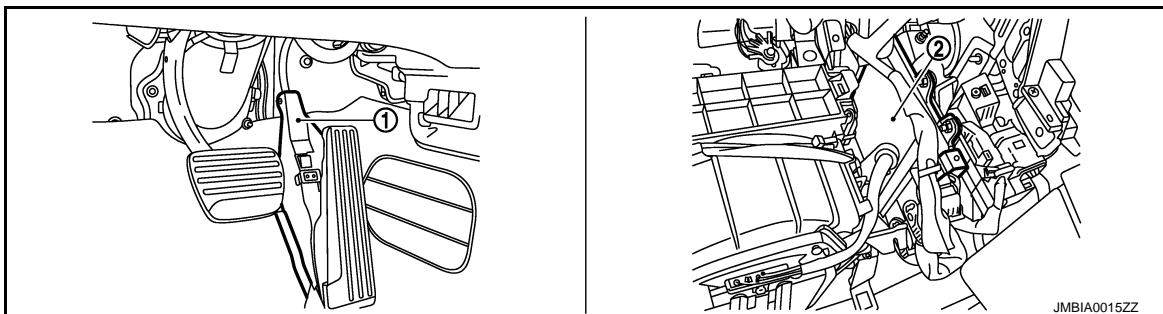

1. Accelerator pedal position sensor 2. ECM

AIR CONDITIONING CUT CONTROL

< SYSTEM DESCRIPTION >

[VQ37VHR]

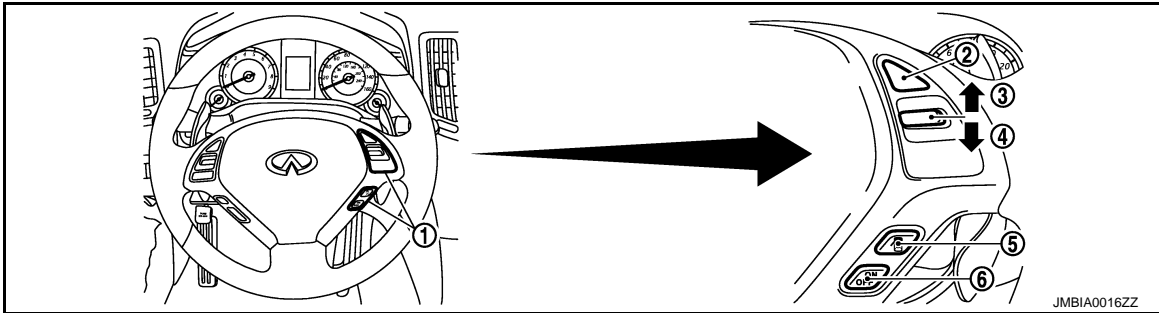

- 1. ICC steering switch
- 2. CANCEL switch
- 3. RESUME/ACCELERATE switch
- 4. SET/COAST switch
- 5. DISTANCE switch
- 6. MAIN switch

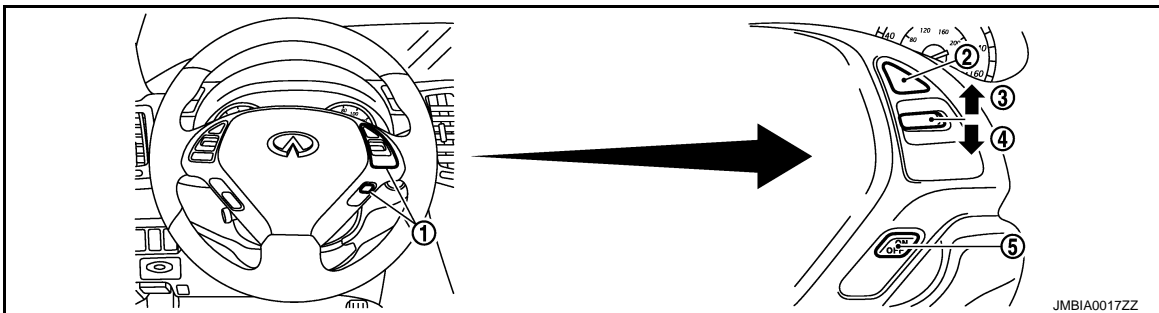

- 1. ASCD steering switch
- 2. CANCEL switch
- 3. RESUME/ACCELERATE switch
- 4. SET/COAST switch
- 5. MAIN switch

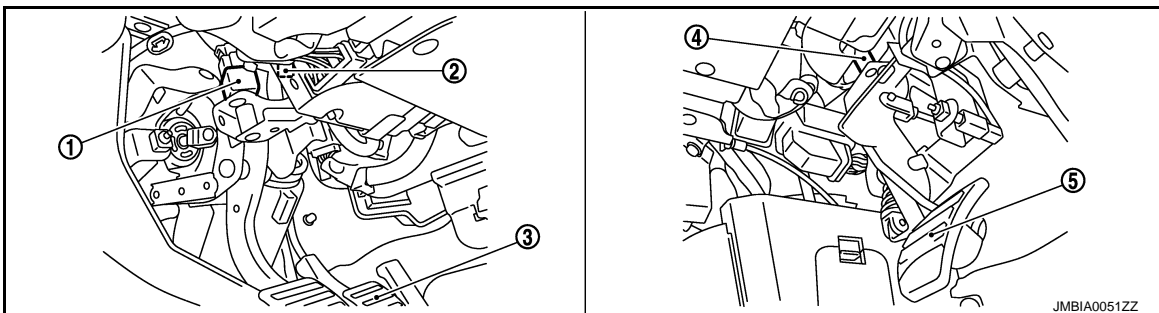

- 1. Stop lamp switch
- 2. ASCD brake switch (ASCD models)
ICC brake switch (ICC models)
- 3. Brake pedal
- 4. ASCD clutch switch (ASCD models)
ICC clutch switch (ICC models)
- 5. Clutch pedal

Component Description

INFOID:000000005151657

Component	Reference
Accelerator pedal position sensor	EC-463. "Description"
Camshaft position sensor (PHASE)	EC-273. "Description"
Crankshaft position sensor (POS)	EC-269. "Description"
Engine coolant temperature sensor	EC-187. "Description"
Power steering pressure sensor	EC-351. "Description"
Refrigerant pressure sensor	EC-516. "Description"

A
EC
C
D
E
F
G
H
I
J
K
L
M
N
O
P

AUTOMATIC SPEED CONTROL DEVICE (ASCD)

< SYSTEM DESCRIPTION >

[VQ37VHR]

AUTOMATIC SPEED CONTROL DEVICE (ASCD)

System Diagram

INFOID:000000005151658

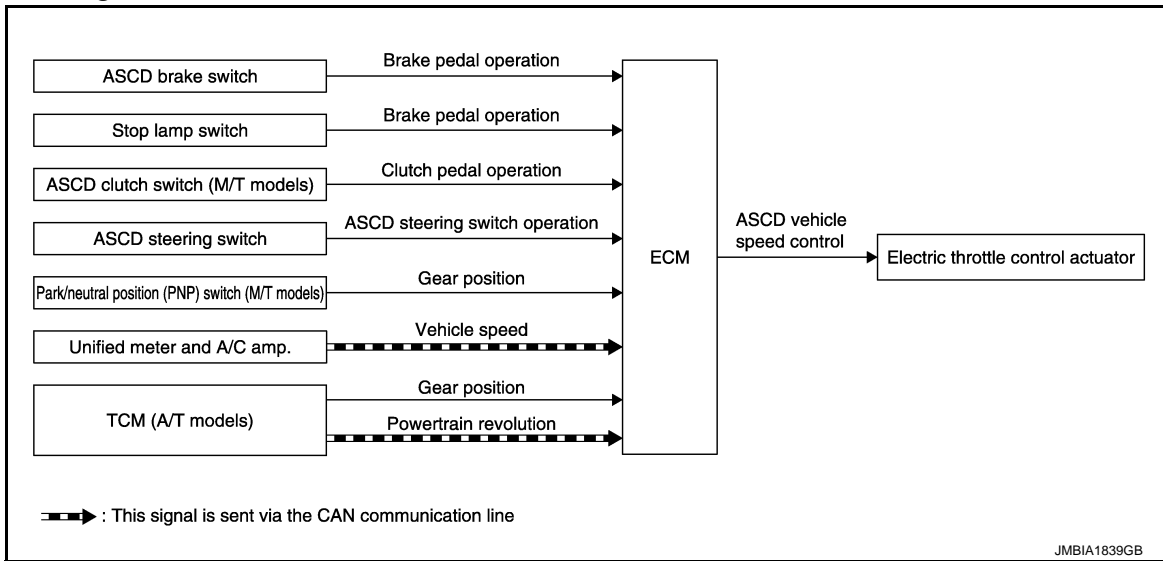

System Description

INFOID:000000005151659

INPUT/OUTPUT SIGNAL CHART

Sensor	Input signal to ECM	ECM function	Actuator
ASCD brake switch	Brake pedal operation	ASCD vehicle speed control	Electric throttle control actuator
Stop lamp switch	Brake pedal operation		
ASCD clutch switch (M/T models)	Clutch pedal operation		
ASCD steering switch	ASCD steering switch operation		
Park/neutral position (PNP) switch (M/T models)	Gear position		
Unified meter and A/C amp.	Vehicle speed*		
TCM (A/T models)	Gear position		
	Powertrain revolution*		

*: This signal is sent to the ECM via the CAN communication line

BASIC ASCD SYSTEM

Refer to Owner's Manual for ASCD operating instructions.

Automatic Speed Control Device (ASCD) allows a driver to keep vehicle at predetermined constant speed without depressing accelerator pedal. Driver can set vehicle speed in advance between approximately 40 km/h (25 MPH) and 144 km/h (89 MPH).

ECM controls throttle angle of electric throttle control actuator to regulate engine speed.

Operation status of ASCD is indicated by CRUISE indicator and SET indicator in combination meter. If any malfunction occurs in the ASCD system, it automatically deactivates control.

NOTE:

Always drive vehicle in a safe manner according to traffic conditions and obey all traffic laws.

SET OPERATION

Press MAIN switch. (The CRUISE indicator in combination meter illuminates.)

When vehicle speed reaches a desired speed between approximately 40 km/h (25 MPH) and 144 km/h (89 MPH), press SET/COAST switch. (Then SET lamp in combination meter illuminates.)

ACCELERATE OPERATION

If the RESUME/ACCELERATE switch is pressed during cruise control driving, increase the vehicle speed until the switch is released or vehicle speed reaches maximum speed controlled by the system.

AUTOMATIC SPEED CONTROL DEVICE (ASCD)

[VQ37VHR]

< SYSTEM DESCRIPTION >

And then ASCD will maintain the new set speed.

CANCEL OPERATION

When any of following conditions exist, cruise operation will be canceled.

- CANCEL switch is pressed
- More than 2 switches at ASCD steering switch are pressed at the same time (Set speed will be cleared)
- Brake pedal is depressed
- Clutch pedal is depressed or gear position is changed to neutral position. (M/T models)
- Selector lever is in the N, P, R position (A/T models)
- Vehicle speed decreased to 13 km/h (8 MPH) lower than the set speed
- TCS system is operated

When the ECM detects any of the following conditions, the ECM will cancel the cruise operation and inform the driver by blinking indicator lamp.

- Engine coolant temperature is slightly higher than the normal operating temperature, CRUISE lamp may blink slowly.

When the engine coolant temperature decreases to the normal operating temperature, CRUISE lamp will stop blinking and the cruise operation will be able to work by pressing SET/COAST switch or RESUME/ACCELERATE switch.

- Malfunction for some self-diagnoses regarding ASCD control: SET indicator will blink quickly.

If MAIN switch is turned to OFF while ASCD is activated, all of ASCD operations will be canceled and vehicle speed memory will be erased.

COAST OPERATION

When the SET/COAST switch is pressed during cruise control driving, decrease vehicle set speed until the switch is released. And then ASCD will maintain the new set speed.

RESUME OPERATION

When the RESUME/ACCELERATE switch is pressed after cancel operation other than pressing MAIN switch is performed, vehicle speed will return to last set speed. To resume vehicle set speed, vehicle condition must meet following conditions.

- Brake pedal is released
- Clutch pedal is released (M/T models)
- A/T selector lever position is other than P and N (A/T models)
- Vehicle speed is greater than 40 km/h (25 MPH) and less than 144 km/h (89 MPH)

A

EC

C

D

E

F

G

H

I

J

K

L

M

N

O

P

AUTOMATIC SPEED CONTROL DEVICE (ASCD)

< SYSTEM DESCRIPTION >

[VQ37VHR]

Component Parts Location

INFOID:000000005151660

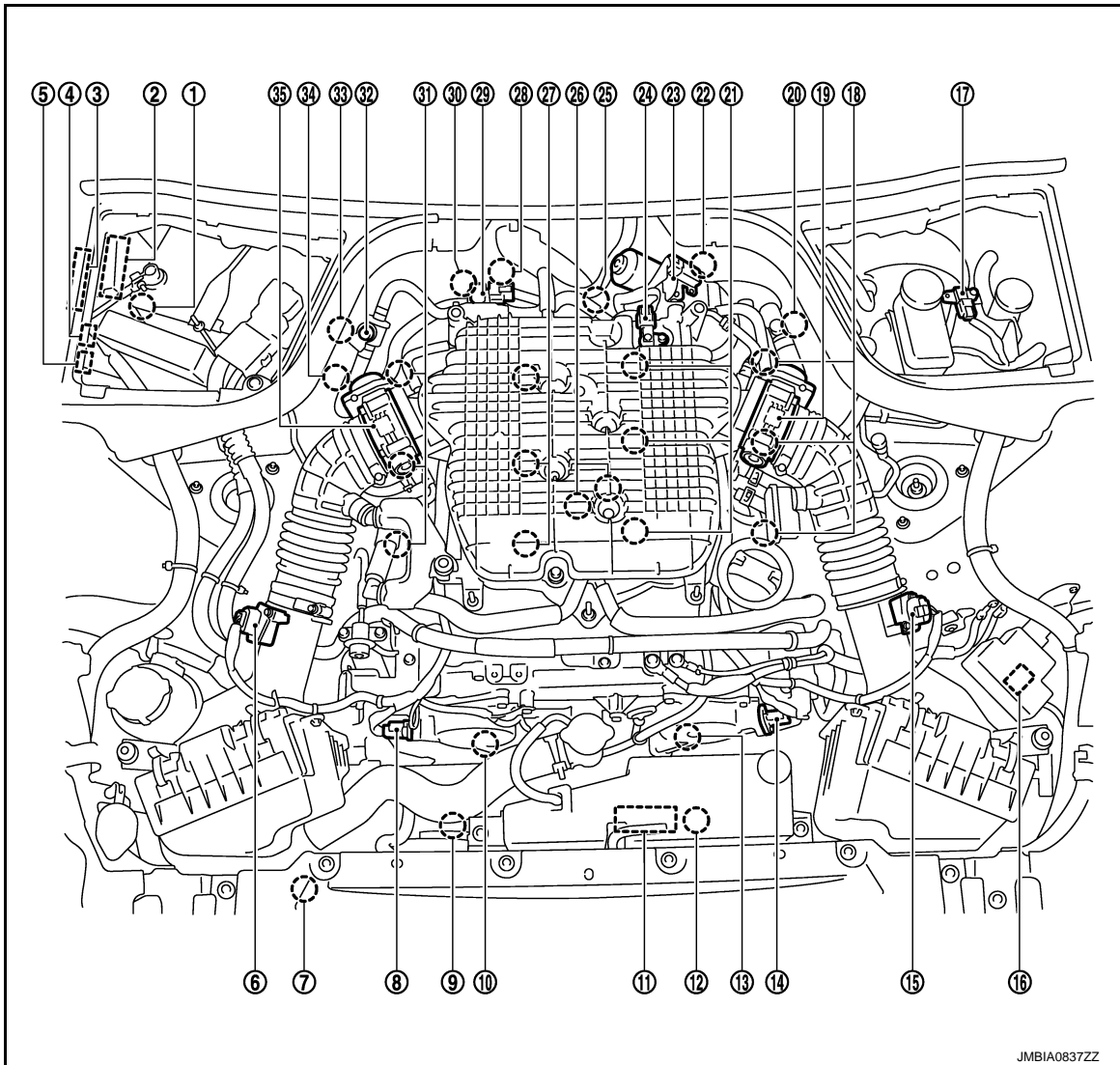

JMBIA0837ZZ

- | | | |
|---|---|---|
| 1. Battery current sensor | 2. IPDM E/R | 3. VVEL control module |
| 4. Cooling fan relay | 5. VVEL actuator motor relay | 6. Mass air flow sensor (with intake air temperature sensor) (bank 1) |
| 7. Refrigerant pressure sensor | 8. Camshaft position sensor (PHASE) (bank 1) | 9. Cooling fan motor-2 |
| 10. Intake valve timing control solenoid valve (bank 1) | 11. Cooling fan control module | 12. Cooling fan motor-1 |
| 13. Intake valve timing control solenoid valve (bank 2) | 14. Camshaft position sensor (PHASE) (bank 2) | 15. Mass air flow sensor (bank 2) |
| 16. ICC brake hold relay (ICC models) | 17. Brake booster pressure sensor | 18. Ignition coil (with power transistor) and spark plug (bank 2) |
| 19. Electric throttle control actuator (bank 2) | 20. A/F sensor 1 (bank 2) | 21. Fuel injector (bank 2) |
| 22. VVEL control shaft position sensor (bank 2) | 23. VVEL actuator motor (bank 2) | 24. Manifold absolute pressure (MAP) sensor |
| 25. Engine coolant temperature sensor | 26. Knock sensor | 27. Fuel injector (bank 1) |
| 28. VVEL actuator motor (bank 1) | 29. EVAP canister purge volume control solenoid valve | 30. VVEL control shaft position sensor (bank 1) |

AUTOMATIC SPEED CONTROL DEVICE (ASCD)

[VQ37VHR]

< SYSTEM DESCRIPTION >

- | | | |
|---|---|---------------------------|
| 31. Ignition coil (with power transistor and spark plug (bank 1)) | 32. EVAP service port | 33. A/F sensor 1 (bank 1) |
| 34. Crankshaft position sensor (POS) | 35. Electric throttle control actuator (bank 1) | |

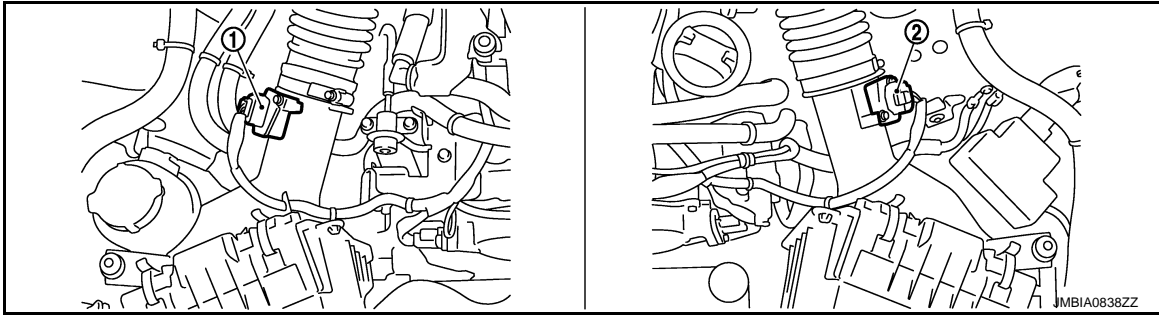

- | | |
|---|----------------------------------|
| 1. Mass air flow sensor (with intake air temperature sensor) (bank 1) | 2. Mass air flow sensor (bank 2) |
|---|----------------------------------|

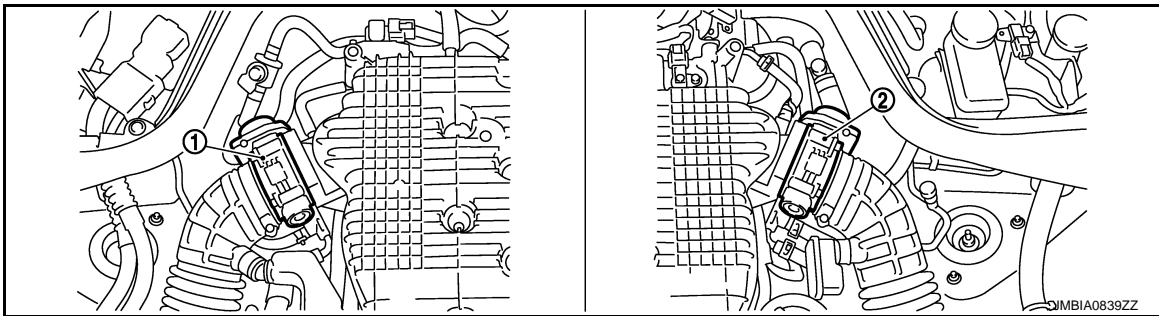

- | | |
|--|--|
| 1. Electric throttle control actuator (bank 1) | 2. Electric throttle control actuator (bank 2) |
|--|--|

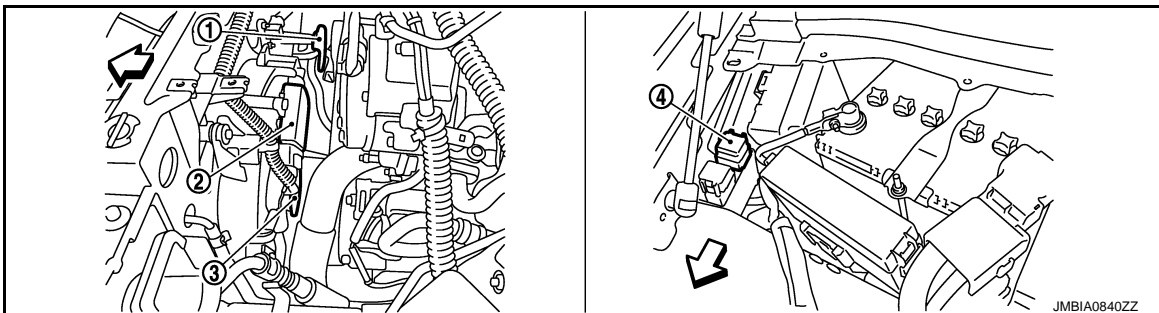

↔ : Vehicle front

- | | | |
|------------------------|-------------------------------|------------------------|
| 1. Cooling fan motor-2 | 2. Cooling fan control module | 3. Cooling fan motor-1 |
| 4. Cooling fan relay | | |

A
EC
C
D
E
F
G
H
I
J
K
L
M
N
O
P

AUTOMATIC SPEED CONTROL DEVICE (ASCD)

< SYSTEM DESCRIPTION >

[VQ37VHR]

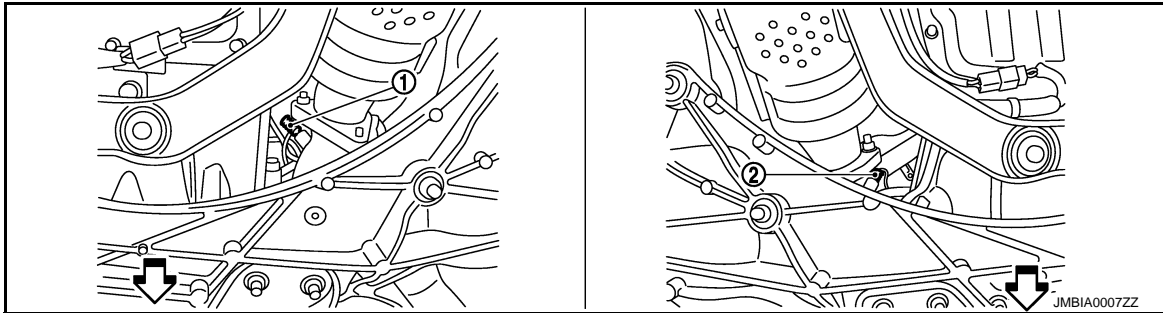
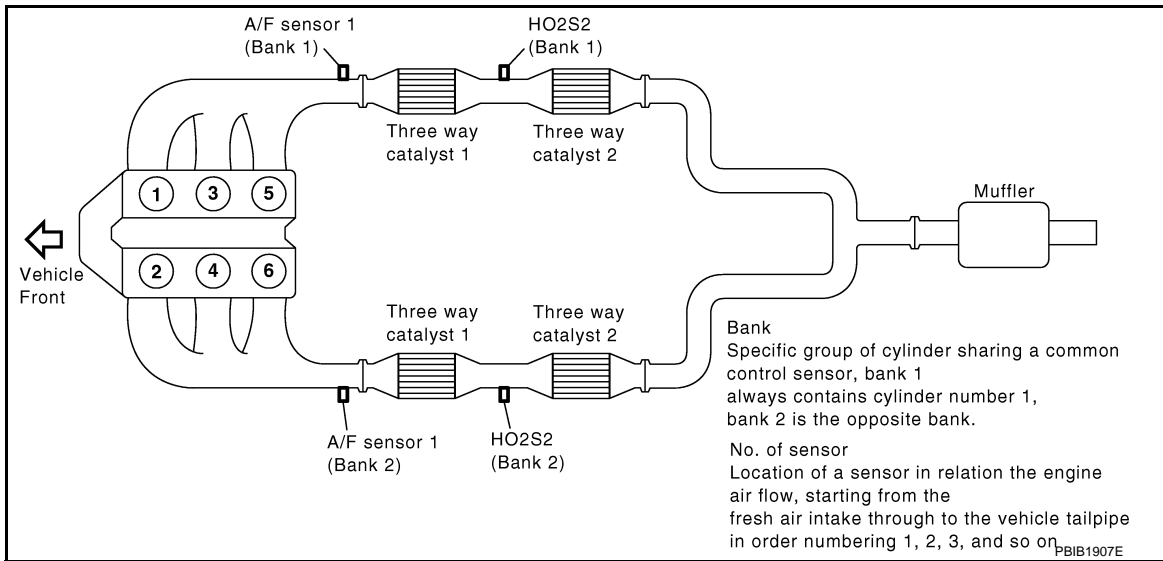

← : Vehicle front

1. A/F sensor 1 (bank 1)
2. A/F sensor 1 (bank 2)

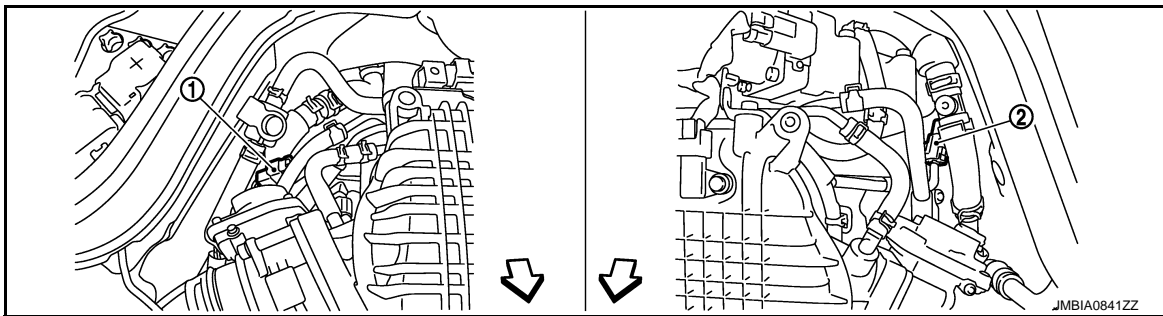

← : Vehicle front

1. A/F sensor 1 (bank 1) harness connector
2. A/F sensor 1 (bank 2) harness connector

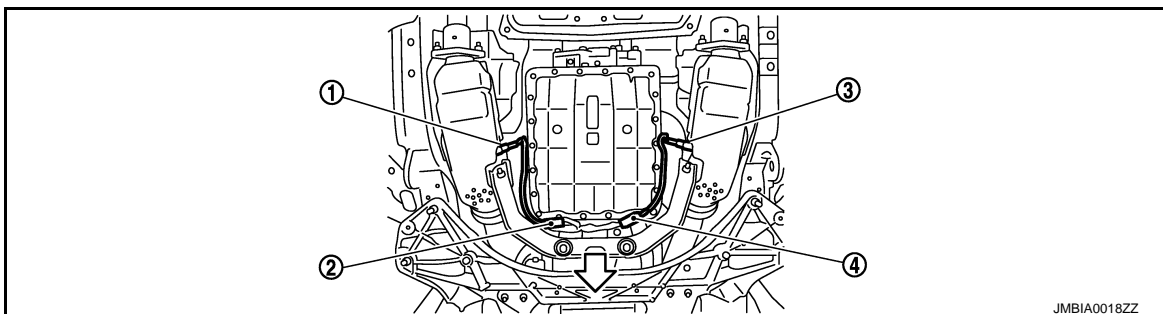

AUTOMATIC SPEED CONTROL DEVICE (ASCD)

[VQ37VHR]

< SYSTEM DESCRIPTION >

↩: Vehicle front

1. Heated oxygen sensor 2 (bank 2)
2. Heated oxygen sensor 2 (bank 2) harness connector
3. Heated oxygen sensor 2 (bank 1)
4. Heated oxygen sensor 2 (bank 1) harness connector

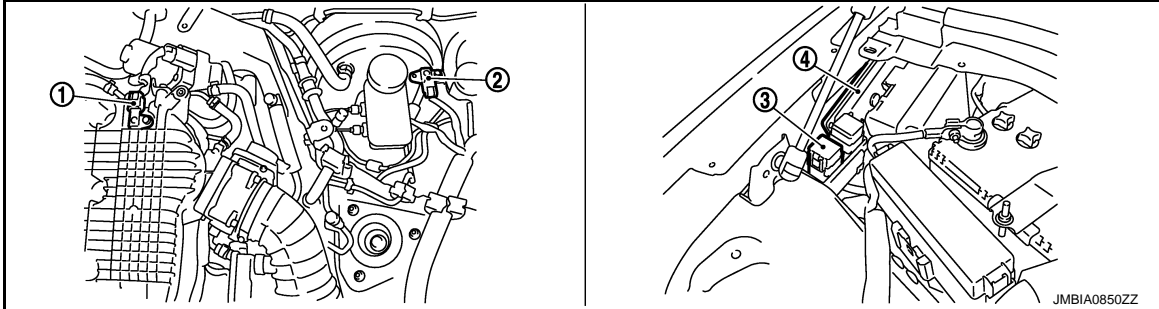

1. Manifold absolute pressure (MAP) sensor
2. Brake booster pressure sensor
3. VVEL actuator motor relay
4. VVEL control module



↩: Vehicle front

1. VVEL control shaft position sensor (bank 1)
2. VVEL actuator motor (bank 1)
3. VVEL actuator motor (bank 2)
4. VVEL control shaft position sensor (bank 2)

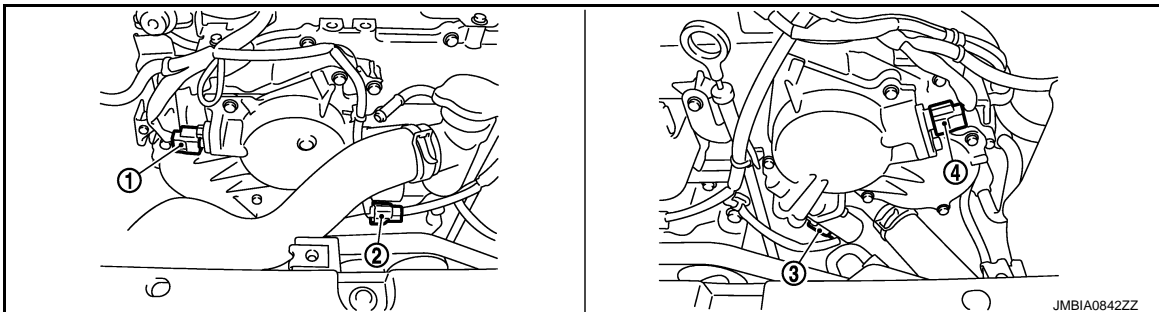

1. Camshaft position sensor (PHASE) (bank 1)
2. Intake valve timing control solenoid valve (bank 1) harness connector
3. Intake valve timing control solenoid valve (bank 2) harness connector
4. Camshaft position sensor (PHASE) (bank 2)

A
EC
C
D
E
F
G
H
I
J
K
L
M
N
O
P

AUTOMATIC SPEED CONTROL DEVICE (ASCD)

< SYSTEM DESCRIPTION >

[VQ37VHR]

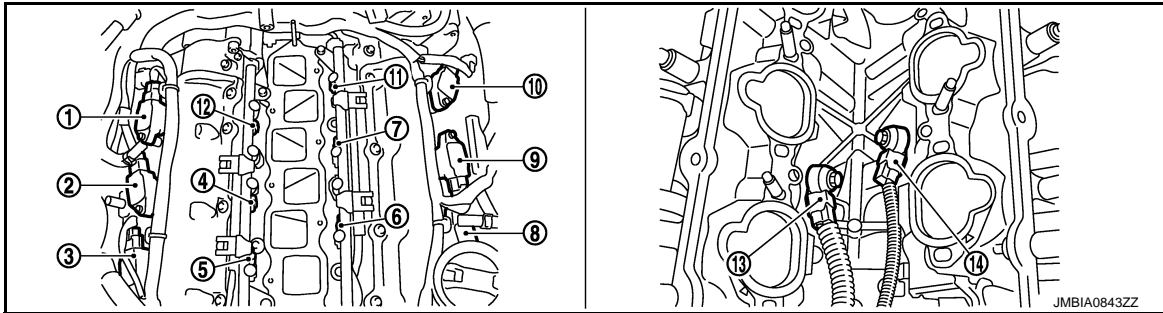

- | | | |
|--|---|---|
| 1. Ignition coil No.5 (with power transistor) | 2. Ignition coil No.3 (with power transistor) | 3. Ignition coil No.1 (with power transistor) |
| 4. Fuel injector No.3 | 5. Fuel injector No.1 | 6. Fuel injector No.2 |
| 7. Fuel injector No.4 | 8. Ignition coil No.2 (with power transistor) | 9. Ignition coil No.4 (with power transistor) |
| 10. Ignition coil No.6 (with power transistor) | 11. Fuel injector No.6 | 12. Fuel injector No.5 |
| 13. Knock sensor (bank 1) | 14. Knock sensor (bank 2) | |

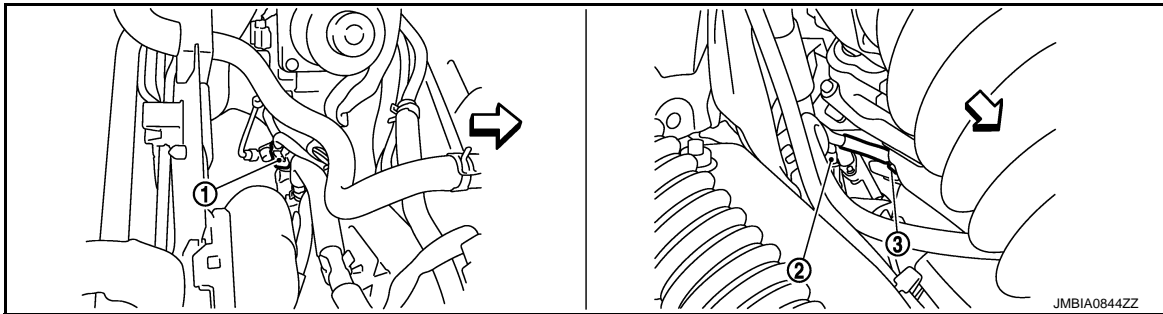

← : Vehicle front

- | | | |
|--------------------------------------|--------------------------|-------------------------------------|
| 1. Engine coolant temperature sensor | 2. A/F sensor 1 (bank 1) | 3. Crankshaft position sensor (POS) |
|--------------------------------------|--------------------------|-------------------------------------|

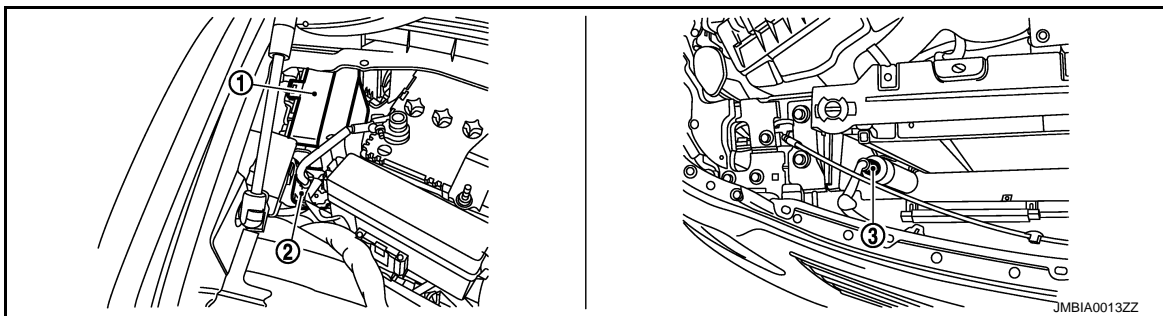

- | | | |
|-------------|---------------------------|--------------------------------|
| 1. IPDM E/R | 2. Battery current sensor | 3. Refrigerant pressure sensor |
|-------------|---------------------------|--------------------------------|

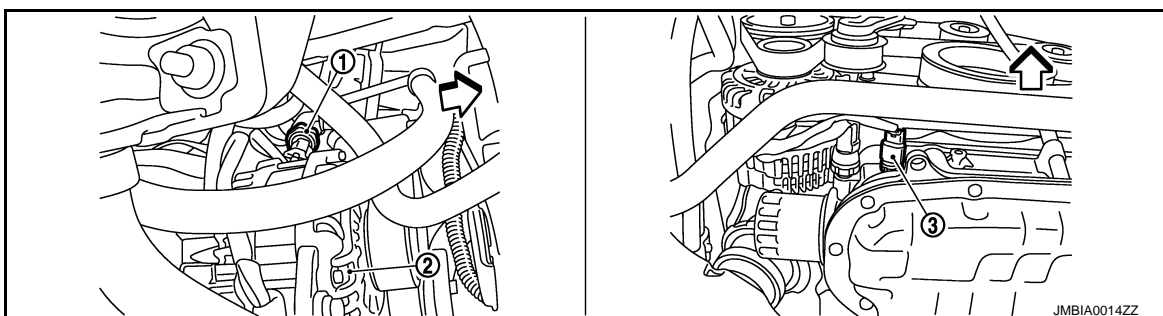

AUTOMATIC SPEED CONTROL DEVICE (ASCD)

[VQ37VHR]

< SYSTEM DESCRIPTION >

↖: Vehicle front

1. Power steering pressure sensor
2. Alternator
3. Engine oil temperature sensor

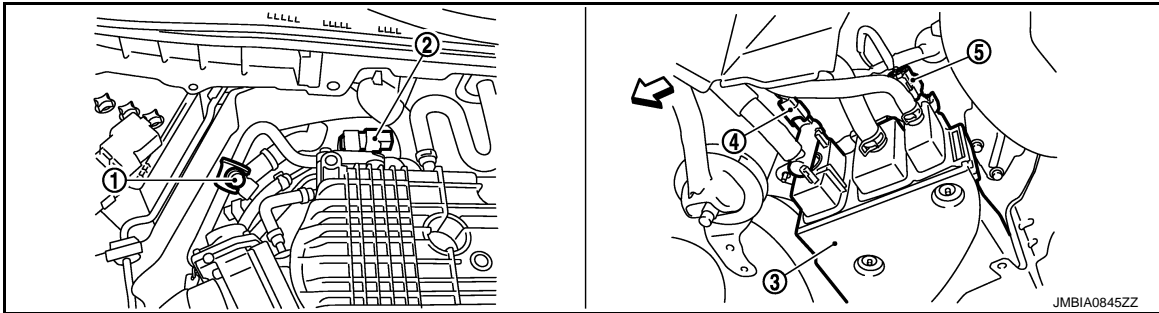

↖: Vehicle front

1. EVAP service port
2. EVAP canister purge volume control
3. EVAP canister solenoid valve
4. EVAP canister vent control valve
5. EVAP control system pressure sensor

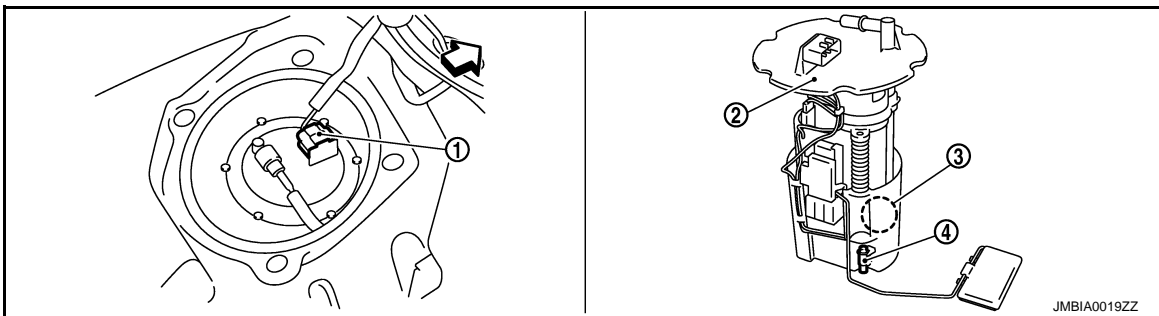

↖: Vehicle front

1. Fuel level sensor unit and fuel pump harness connector
2. Fuel level sensor unit and fuel pump
3. Fuel pressure regulator
4. Fuel tank temperature sensor

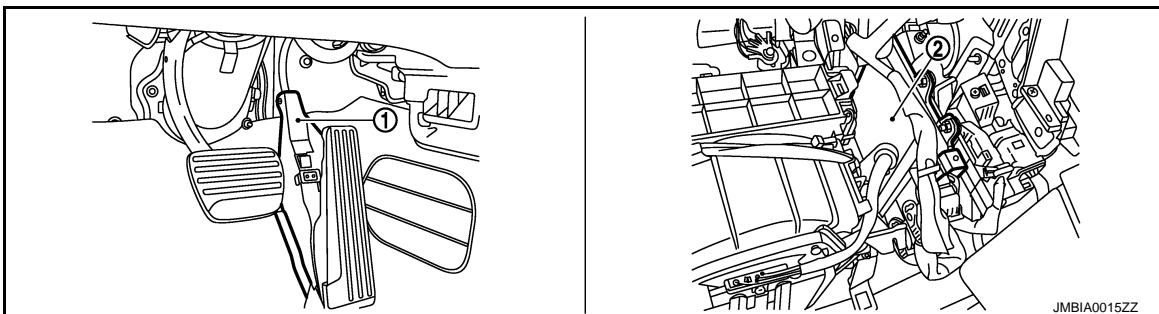

1. Accelerator pedal position sensor
2. ECM

A
EC
C
D
E
F
G
H
I
J
K
L
M
N
O
P

AUTOMATIC SPEED CONTROL DEVICE (ASCD)

< SYSTEM DESCRIPTION >

[VQ37VHR]

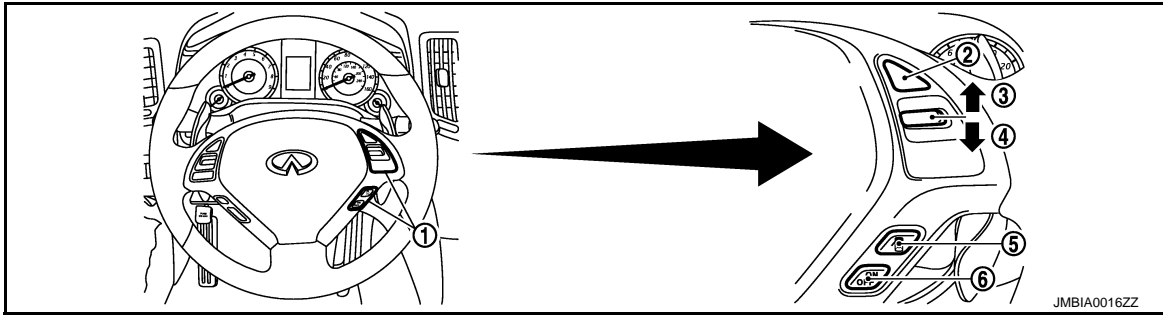

- 1. ICC steering switch
- 2. CANCEL switch
- 3. RESUME/ACCELERATE switch
- 4. SET/COAST switch
- 5. DISTANCE switch
- 6. MAIN switch

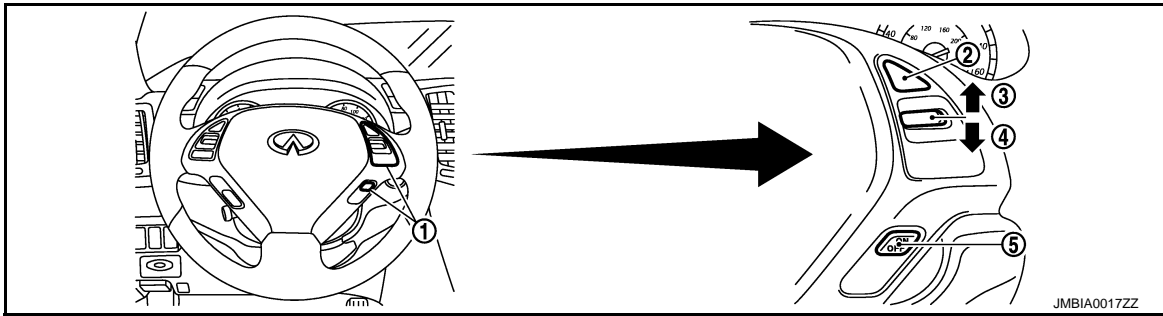

- 1. ASCD steering switch
- 2. CANCEL switch
- 3. RESUME/ACCELERATE switch
- 4. SET/COAST switch
- 5. MAIN switch

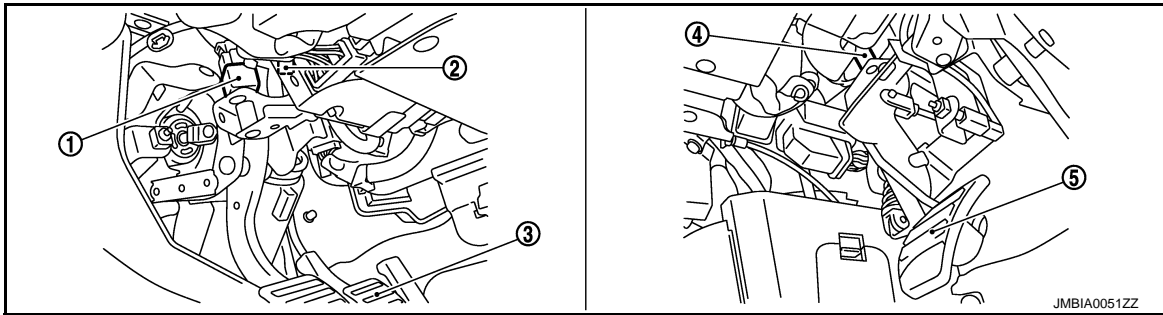

- 1. Stop lamp switch
- 2. ASCD brake switch (ASCD models) ICC brake switch (ICC models)
- 3. Brake pedal
- 4. ASCD clutch switch (ASCD models) ICC clutch switch (ICC models)
- 5. Clutch pedal

Component Description

INFOID:000000005151661

Component	Reference
ASCD brake switch	EC-434. "Description"
ASCD indicator	EC-485. "Description"
ASCD steering switch	EC-427. "Description"
Electric throttle control actuator	EC-410. "Description"
Stop lamp switch	EC-434. "Description"

CAN COMMUNICATION

System Description

INFOID:000000005151662

CAN (Controller Area Network) is a serial communication line for real time application. It is an on-vehicle multiplex communication line with high data communication speed and excellent error detection ability. Many electronic control units are equipped onto a vehicle, and each control unit shares information and links with other control units during operation (not independent). In CAN communication, control units are connected with 2 communication lines (CAN H line, CAN L line) allowing a high rate of information transmission with less wiring. Each control unit transmits/receives data but selectively reads required data only.

Refer to [LAN-7. "CAN Communication Control Circuit"](#), about CAN communication for detail..

A

EC

C

D

E

F

G

H

I

J

K

L

M

N

O

P

COOLING FAN CONTROL

< SYSTEM DESCRIPTION >

[VQ37VHR]

COOLING FAN CONTROL

System Diagram

INFOID:000000005151663

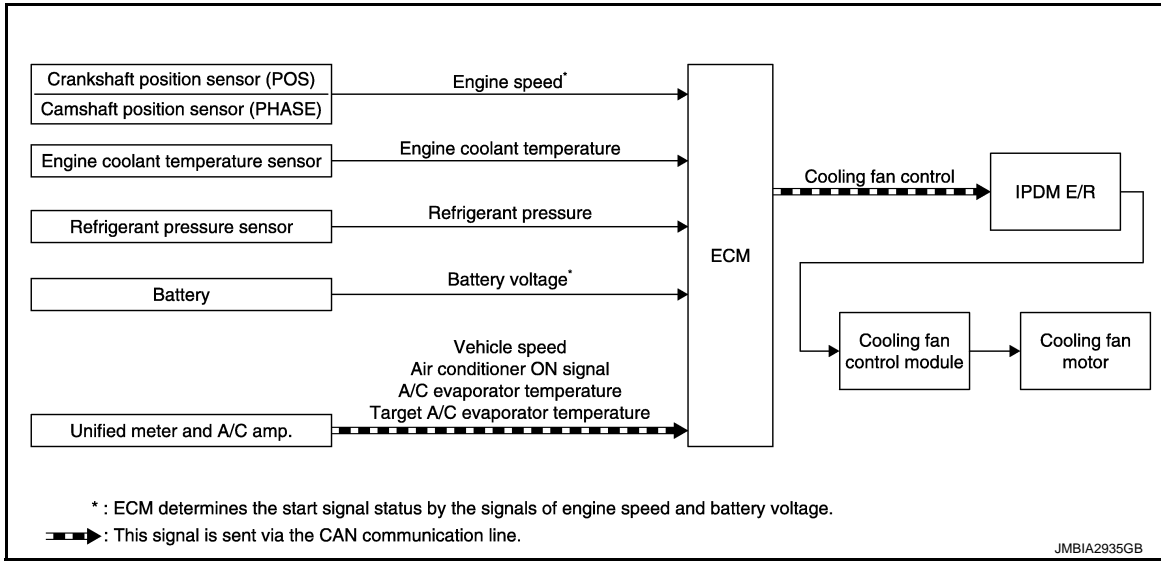

JMBIA2935GB

System Description

INFOID:000000005151664

INPUT/OUTPUT SIGNAL CHART

Sensor	Input signal to ECM	ECM function	Actuator
Crankshaft position sensor (POS) Camshaft position sensor (PHASE)	Engine speed* ¹	Cooling fan control	IPDM E/R ↓ Cooling fan control module ↓ Cooling fan motor
Engine coolant temperature sensor	Engine coolant temperature		
Refrigerant pressure sensor	Refrigerant pressure		
Battery	Battery voltage* ¹		
Unified meter and A/C amp.	Vehicle speed* ²		
	Air conditioner ON signal* ²		
	A/C evaporator temperature* ²		
	Target A/C evaporator temperature* ²		

*1: The ECM determines the start signal status by the signals of engine speed and battery voltage.

*2: This signal is sent to ECM via the CAN communication line.

SYSTEM DESCRIPTION

ECM controls cooling fan speed corresponding to vehicle speed, engine coolant temperature, air conditioner ON signal, refrigerant pressure, target A/C evaporator temperature and A/C evaporator temperature.

Cooling fan control signal is sent to IPDM E/R from ECM by CAN communication line. Then, IPDM E/R sends ON/OFF pulse duty signal to cooling fan control module. Corresponding to this ON/OFF pulse duty signal, cooling fan control module gives cooling fan motor operating voltage to cooling fan motors. Cooling fan speed is controlled by duty cycle of cooling fan motor operating voltage sent from cooling fan control module.

COOLING FAN CONTROL

< SYSTEM DESCRIPTION >

[VQ37VHR]

Component Parts Location

INFOID:000000005151665

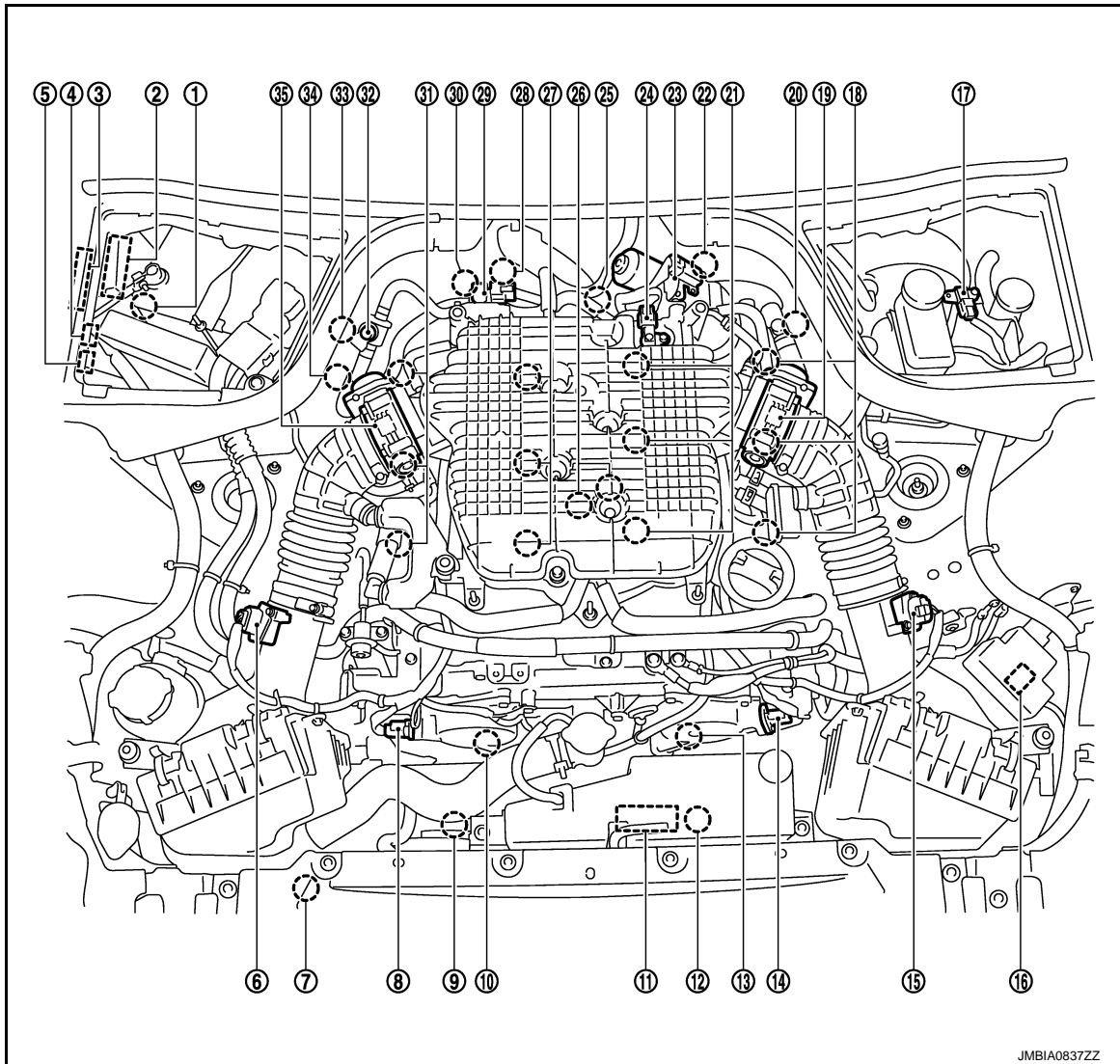

- | | | |
|---|---|---|
| 1. Battery current sensor | 2. IPDM E/R | 3. VVEL control module |
| 4. Cooling fan relay | 5. VVEL actuator motor relay | 6. Mass air flow sensor (with intake air temperature sensor) (bank 1) |
| 7. Refrigerant pressure sensor | 8. Camshaft position sensor (PHASE) (bank 1) | 9. Cooling fan motor-2 |
| 10. Intake valve timing control solenoid valve (bank 1) | 11. Cooling fan control module | 12. Cooling fan motor-1 |
| 13. Intake valve timing control solenoid valve (bank 2) | 14. Camshaft position sensor (PHASE) (bank 2) | 15. Mass air flow sensor (bank 2) |
| 16. ICC brake hold relay (ICC models) | 17. Brake booster pressure sensor | 18. Ignition coil (with power transistor and spark plug) (bank 2) |
| 19. Electric throttle control actuator (bank 2) | 20. A/F sensor 1 (bank 2) | 21. Fuel injector (bank 2) |
| 22. VVEL control shaft position sensor (bank 2) | 23. VVEL actuator motor (bank 2) | 24. Manifold absolute pressure (MAP) sensor |
| 25. Engine coolant temperature sensor | 26. Knock sensor | 27. Fuel injector (bank 1) |
| 28. VVEL actuator motor (bank 1) | 29. EVAP canister purge volume control solenoid valve | 30. VVEL control shaft position sensor (bank 1) |

COOLING FAN CONTROL

[VQ37VHR]

< SYSTEM DESCRIPTION >

- | | | |
|---|---|---------------------------|
| 31. Ignition coil (with power transistor and spark plug (bank 1)) | 32. EVAP service port | 33. A/F sensor 1 (bank 1) |
| 34. Crankshaft position sensor (POS) | 35. Electric throttle control actuator (bank 1) | |

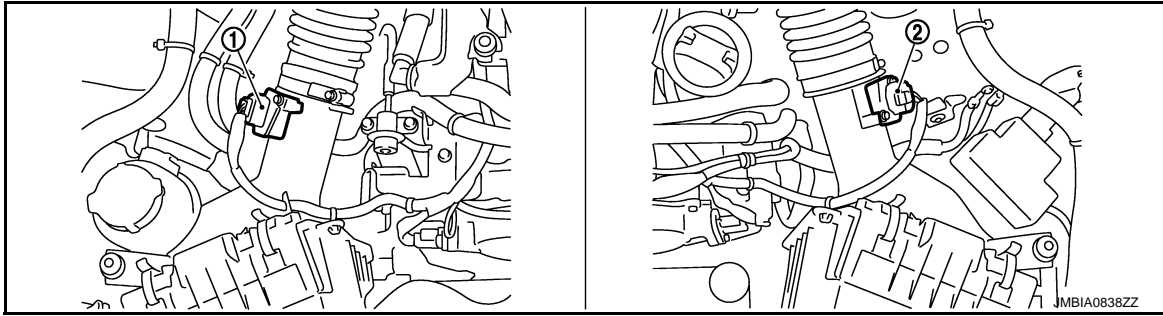

- | | |
|---|----------------------------------|
| 1. Mass air flow sensor (with intake air temperature sensor) (bank 1) | 2. Mass air flow sensor (bank 2) |
|---|----------------------------------|

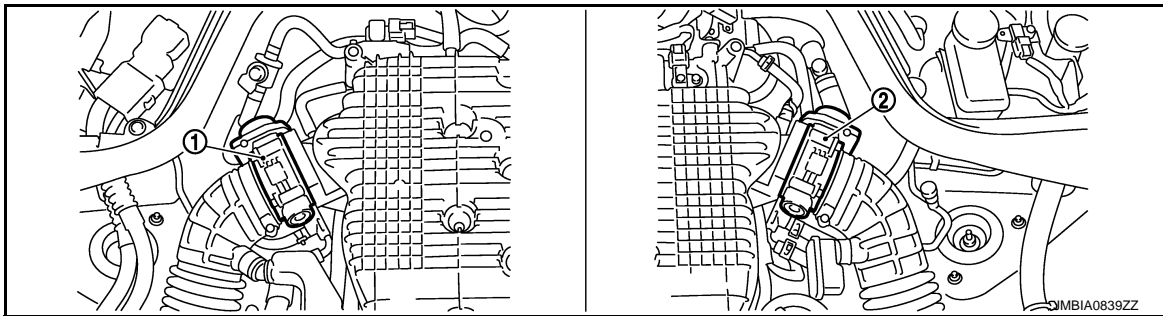

- | | |
|--|--|
| 1. Electric throttle control actuator (bank 1) | 2. Electric throttle control actuator (bank 2) |
|--|--|

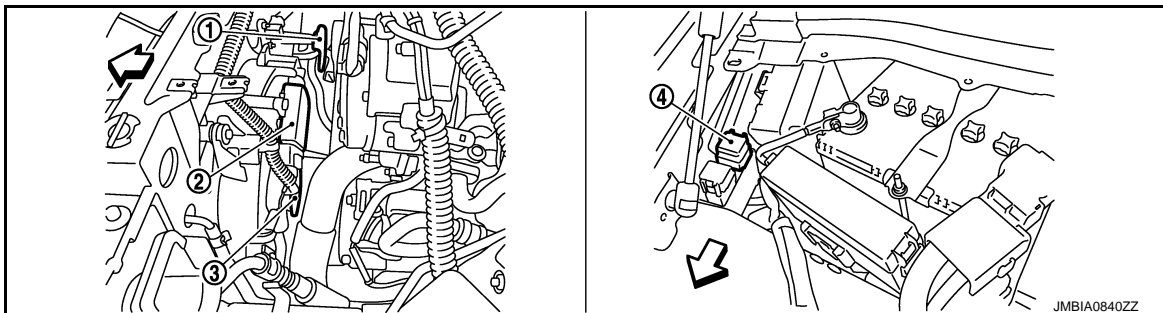

◀ : Vehicle front

- | | | |
|------------------------|-------------------------------|------------------------|
| 1. Cooling fan motor-2 | 2. Cooling fan control module | 3. Cooling fan motor-1 |
| 4. Cooling fan relay | | |

COOLING FAN CONTROL

< SYSTEM DESCRIPTION >

[VQ37VHR]

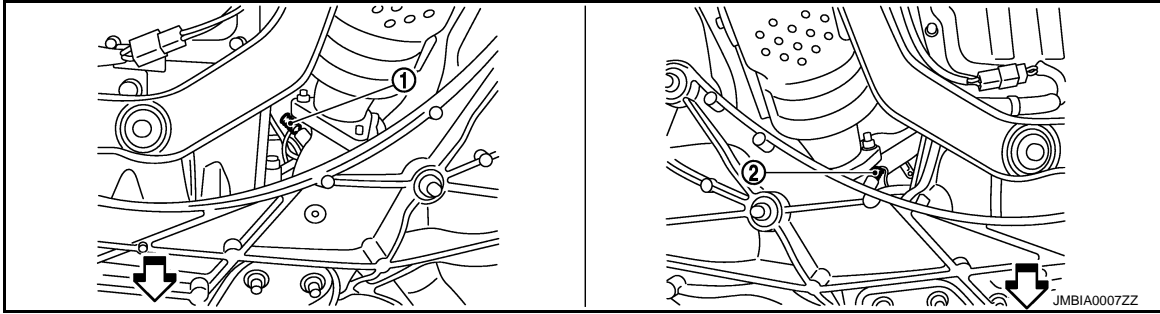
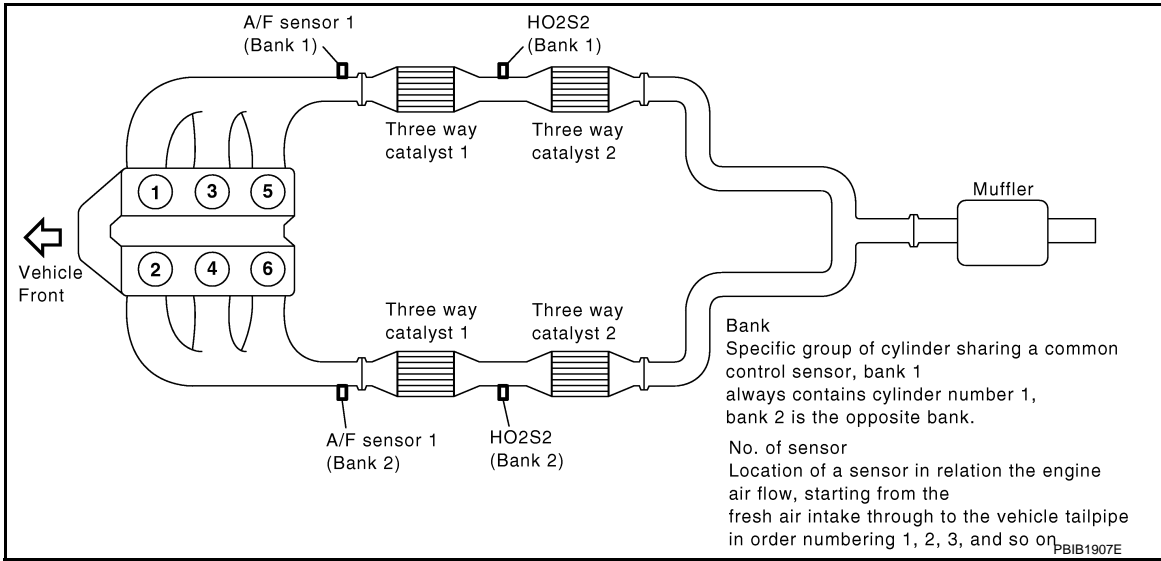

↔: Vehicle front

1. A/F sensor 1 (bank 1)
2. A/F sensor 1 (bank 2)

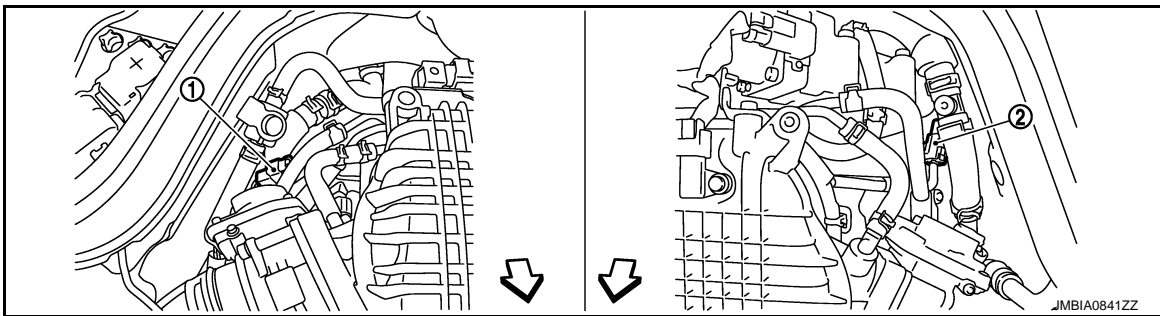

↔: Vehicle front

1. A/F sensor 1 (bank 1) harness connector
2. A/F sensor 1 (bank 2) harness connector

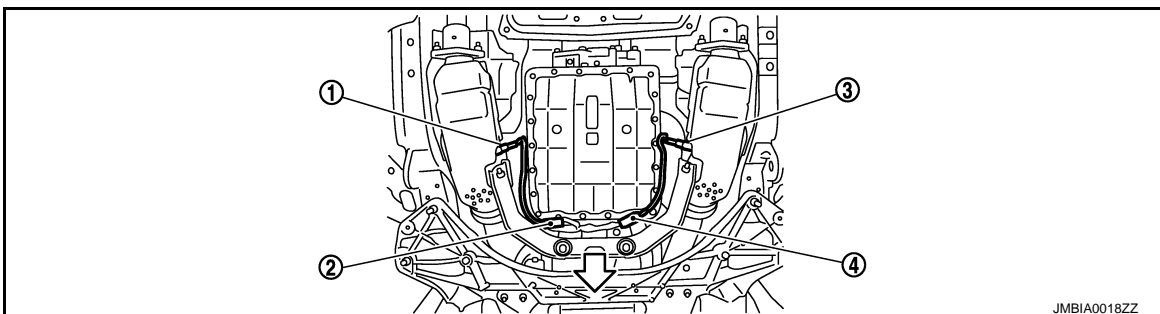

COOLING FAN CONTROL

[VQ37VHR]

< SYSTEM DESCRIPTION >

↙ : Vehicle front

1. Heated oxygen sensor 2 (bank 2)
2. Heated oxygen sensor 2 (bank 2) harness connector
3. Heated oxygen sensor 2 (bank 1)
4. Heated oxygen sensor 2 (bank 1) harness connector

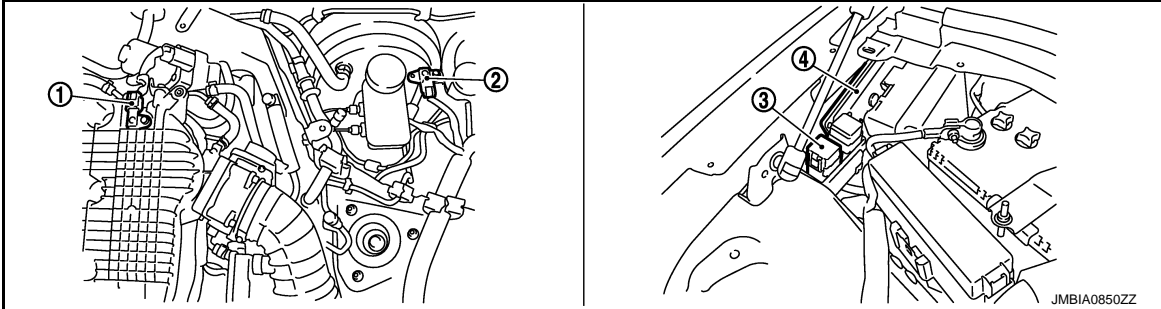

1. Manifold absolute pressure (MAP) sensor
2. Brake booster pressure sensor
3. VVEL actuator motor relay
4. VVEL control module



↙ : Vehicle front

1. VVEL control shaft position sensor (bank 1)
2. VVEL actuator motor (bank 1)
3. VVEL actuator motor (bank 2)
4. VVEL control shaft position sensor (bank 2)

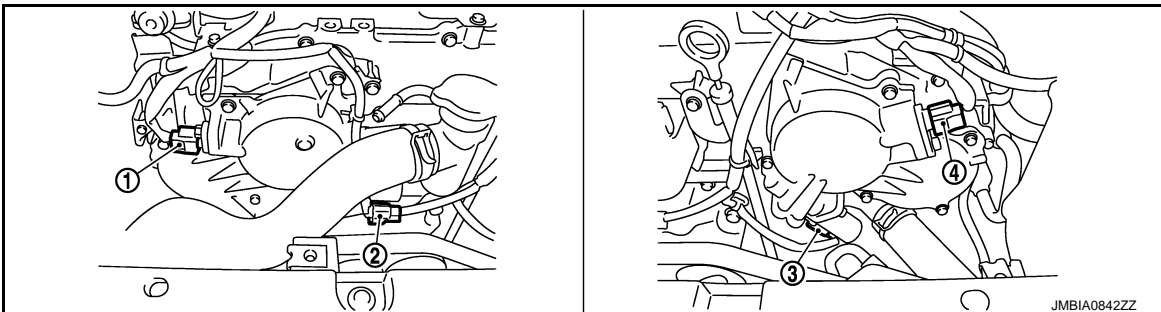

1. Camshaft position sensor (PHASE) (bank 1)
2. Intake valve timing control solenoid valve (bank 1) harness connector
3. Intake valve timing control solenoid valve (bank 2) harness connector
4. Camshaft position sensor (PHASE) (bank 2)

COOLING FAN CONTROL

< SYSTEM DESCRIPTION >

[VQ37VHR]

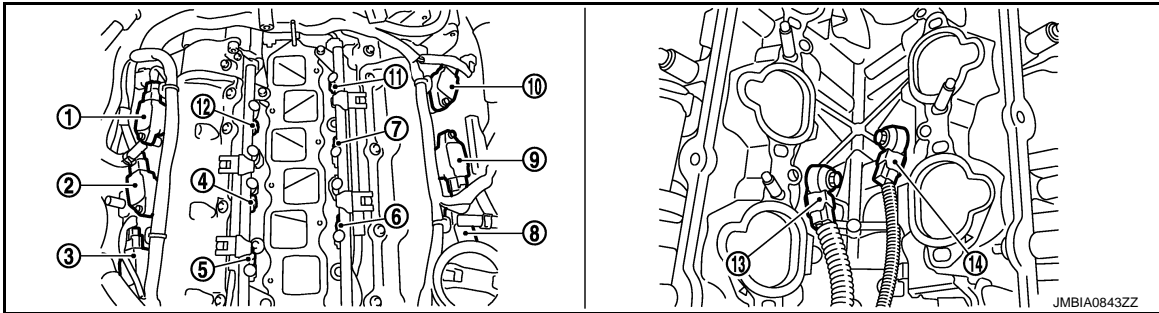

- | | | |
|--|---|---|
| 1. Ignition coil No.5 (with power transistor) | 2. Ignition coil No.3 (with power transistor) | 3. Ignition coil No.1 (with power transistor) |
| 4. Fuel injector No.3 | 5. Fuel injector No.1 | 6. Fuel injector No.2 |
| 7. Fuel injector No.4 | 8. Ignition coil No.2 (with power transistor) | 9. Ignition coil No.4 (with power transistor) |
| 10. Ignition coil No.6 (with power transistor) | 11. Fuel injector No.6 | 12. Fuel injector No.5 |
| 13. Knock sensor (bank 1) | 14. Knock sensor (bank 2) | |

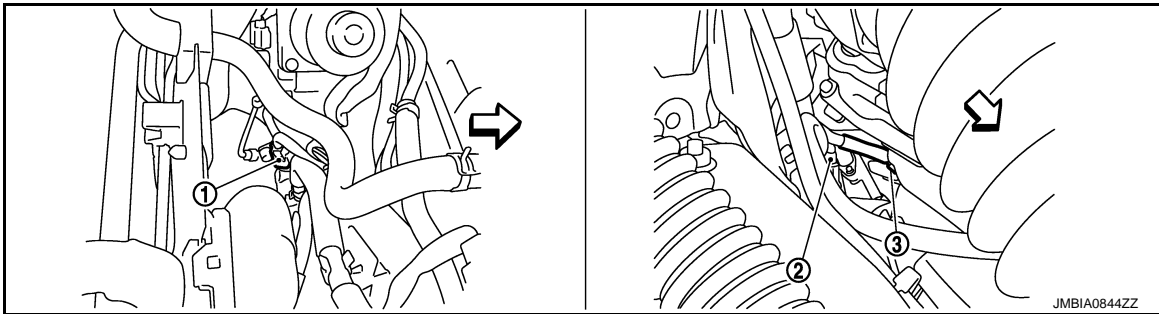

↔ : Vehicle front

- | | | |
|--------------------------------------|--------------------------|-------------------------------------|
| 1. Engine coolant temperature sensor | 2. A/F sensor 1 (bank 1) | 3. Crankshaft position sensor (POS) |
|--------------------------------------|--------------------------|-------------------------------------|

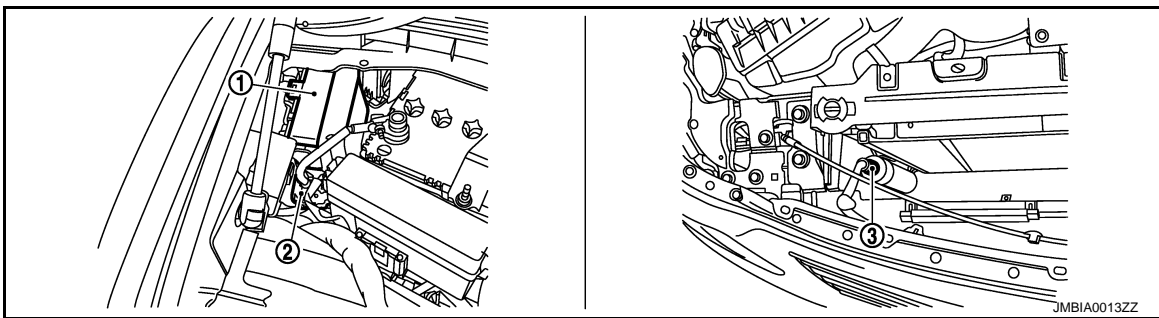

- | | | |
|-------------|---------------------------|--------------------------------|
| 1. IPDM E/R | 2. Battery current sensor | 3. Refrigerant pressure sensor |
|-------------|---------------------------|--------------------------------|

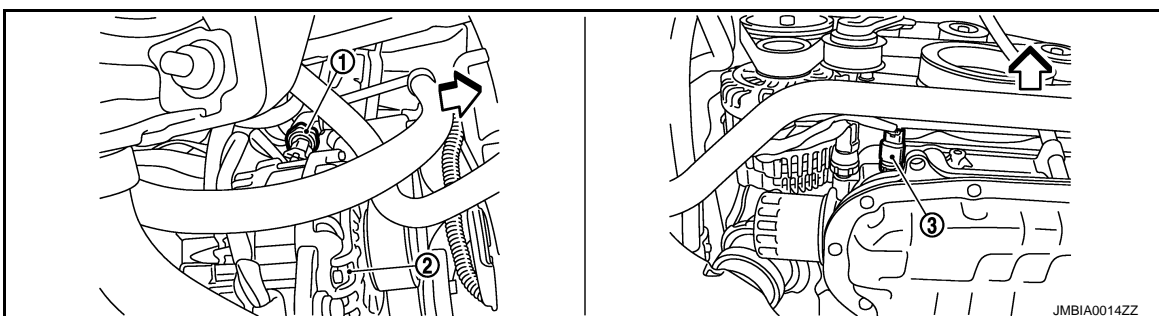

A
EC
C
D
E
F
G
H
I
J
K
L
M
N
O
P

COOLING FAN CONTROL

[VQ37VHR]

< SYSTEM DESCRIPTION >

↶ : Vehicle front

1. Power steering pressure sensor 2. Alternator 3. Engine oil temperature sensor

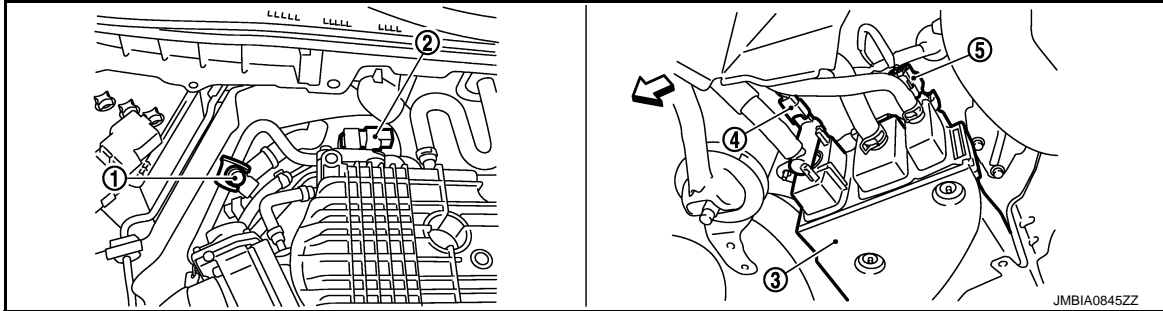

↶ : Vehicle front

1. EVAP service port 2. EVAP canister purge volume control 3. EVAP canister solenoid valve
4. EVAP canister vent control valve 5. EVAP control system pressure sensor

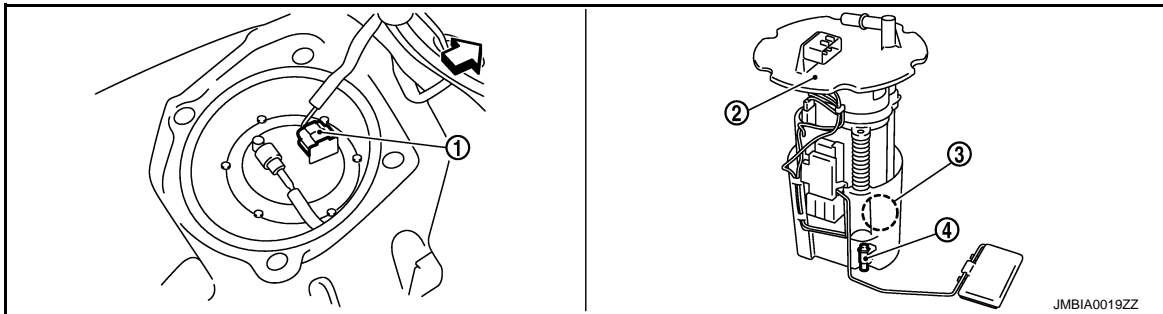

↶ : Vehicle front

1. Fuel level sensor unit and fuel pump 2. Fuel level sensor unit and fuel pump 3. Fuel pressure regulator harness connector
4. Fuel tank temperature sensor

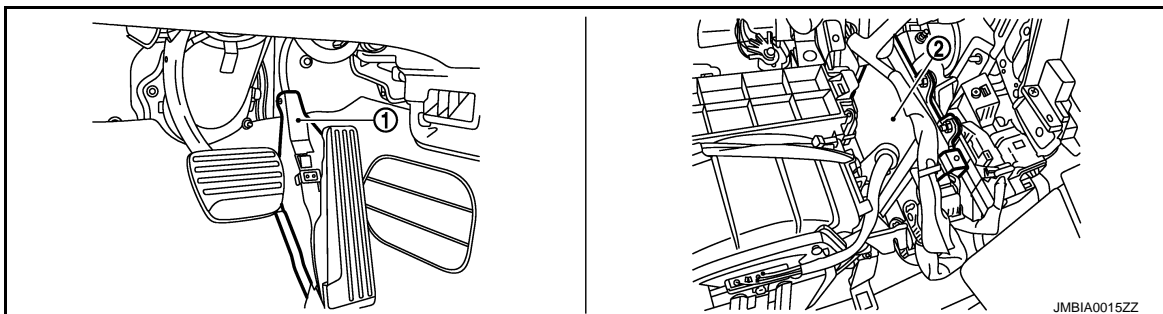

1. Accelerator pedal position sensor 2. ECM

COOLING FAN CONTROL

< SYSTEM DESCRIPTION >

[VQ37VHR]

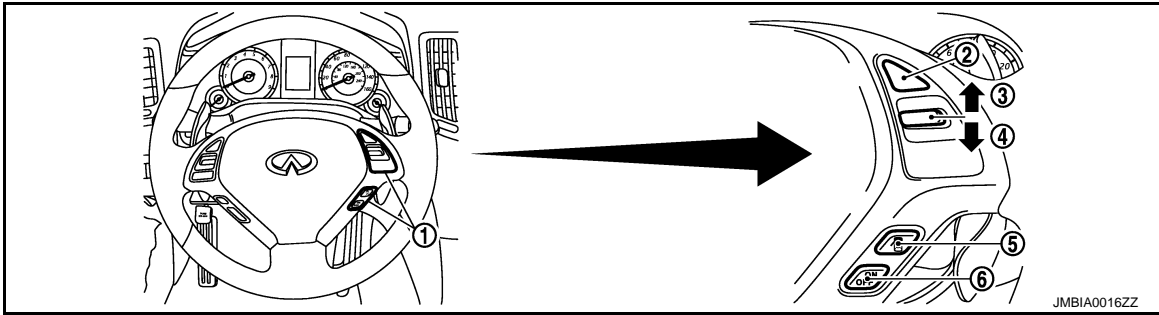

- 1. ICC steering switch
- 2. CANCEL switch
- 3. RESUME/ACCELERATE switch
- 4. SET/COAST switch
- 5. DISTANCE switch
- 6. MAIN switch

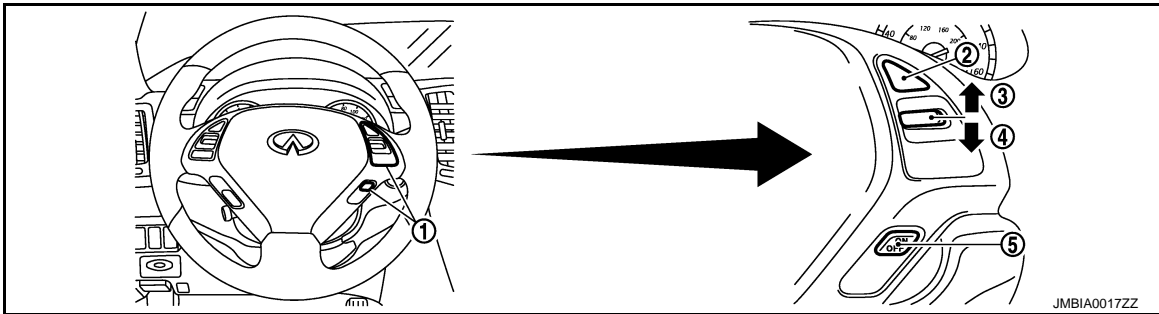

- 1. ASCD steering switch
- 2. CANCEL switch
- 3. RESUME/ACCELERATE switch
- 4. SET/COAST switch
- 5. MAIN switch

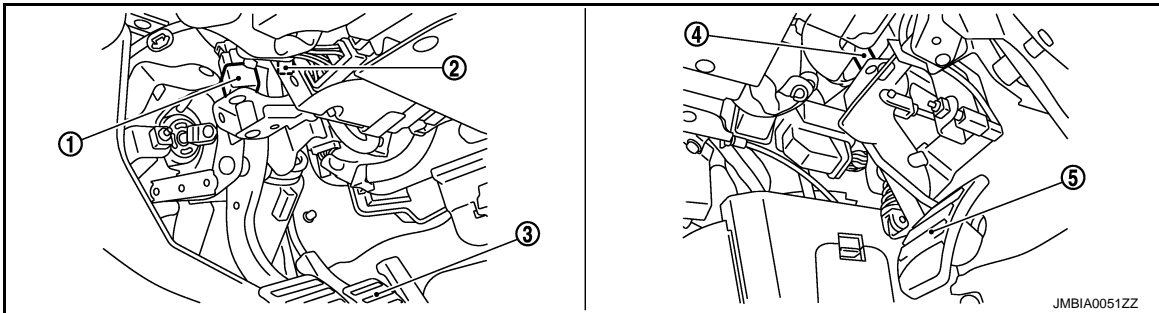

- 1. Stop lamp switch
- 2. ASCD brake switch (ASCD models)
ICC brake switch (ICC models)
- 3. Brake pedal
- 4. ASCD clutch switch (ASCD models)
ICC clutch switch (ICC models)
- 5. Clutch pedal

Component Description

INFOID:000000005151666

Component	Reference
Camshaft position sensor (PHASE)	EC-273. "Description"
Cooling fan control module	EC-486. "Description"
Cooling fan motor	EC-486. "Description"
Crankshaft position sensor (POS)	EC-269. "Description"
Engine coolant temperature sensor	EC-187. "Description"
Refrigerant pressure sensor	EC-516. "Description"

A
EC
C
D
E
F
G
H
I
J
K
L
M
N
O
P

EVAPORATIVE EMISSION SYSTEM

< SYSTEM DESCRIPTION >

[VQ37VHR]

EVAPORATIVE EMISSION SYSTEM

System Diagram

INFOID:000000005151667

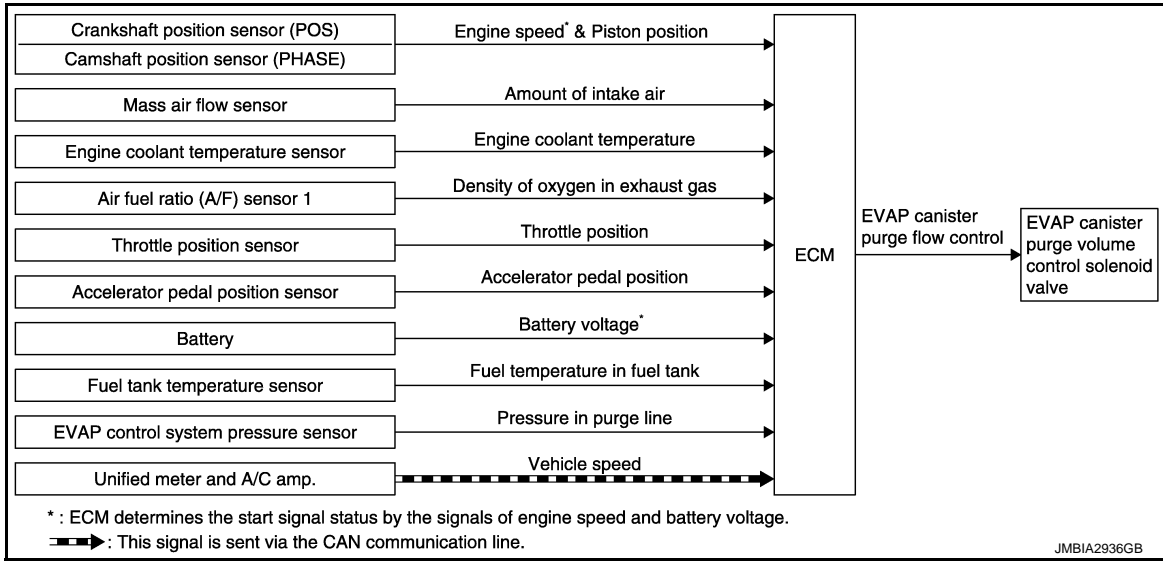

System Description

INFOID:000000005151668

INPUT/OUTPUT SIGNAL CHART

Sensor	Input signal to ECM	ECM function	Actuator
Crankshaft position sensor (POS) Camshaft position sensor (PHASE)	Engine speed*1	EVAP canister purge flow control	EVAP canister purge vol- ume control solenoid valve
Mass air flow sensor	Amount of intake air		
Engine coolant temperature sensor	Engine coolant temperature		
Battery	Battery voltage*1		
Throttle position sensor	Throttle position		
Accelerator pedal position sensor	Accelerator pedal position		
Air fuel ratio (A/F) sensor 1	Density of oxygen in exhaust gas (Mixture ratio feedback signal)		
Fuel tank temperature sensor	Fuel temperature in fuel tank		
EVAP control system pressure sensor	Pressure in purge line		
Unified meter and A/C amp.	Vehicle speed*2		

*1: ECM determines the start signal status by the signals of engine speed and battery voltage.

*2: This signal is sent to the ECM via the CAN communication line.

EVAPORATIVE EMISSION SYSTEM

< SYSTEM DESCRIPTION >

[VQ37VHR]

SYSTEM DESCRIPTION

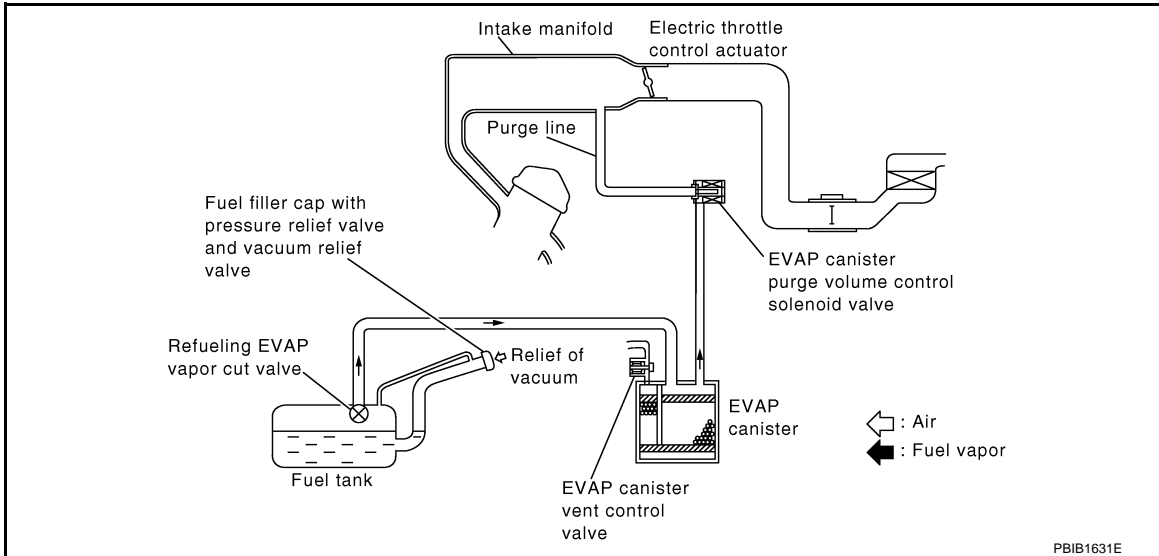

The evaporative emission system is used to reduce hydrocarbons emitted into the atmosphere from the fuel system. This reduction of hydrocarbons is accomplished by activated charcoals in the EVAP canister. The fuel vapor in the sealed fuel tank is led into the EVAP canister which contains activated carbon and the vapor is stored there when the engine is not operating or when refueling to the fuel tank. The vapor in the EVAP canister is purged by the air through the purge line to the intake manifold when the engine is operating. EVAP canister purge volume control solenoid valve is controlled by ECM. When the engine operates, the flow rate of vapor controlled by EVAP canister purge volume control solenoid valve is proportionally regulated as the air flow increases. EVAP canister purge volume control solenoid valve also shuts off the vapor purge line during decelerating and idling.

EVAPORATIVE EMISSION LINE DRAWING

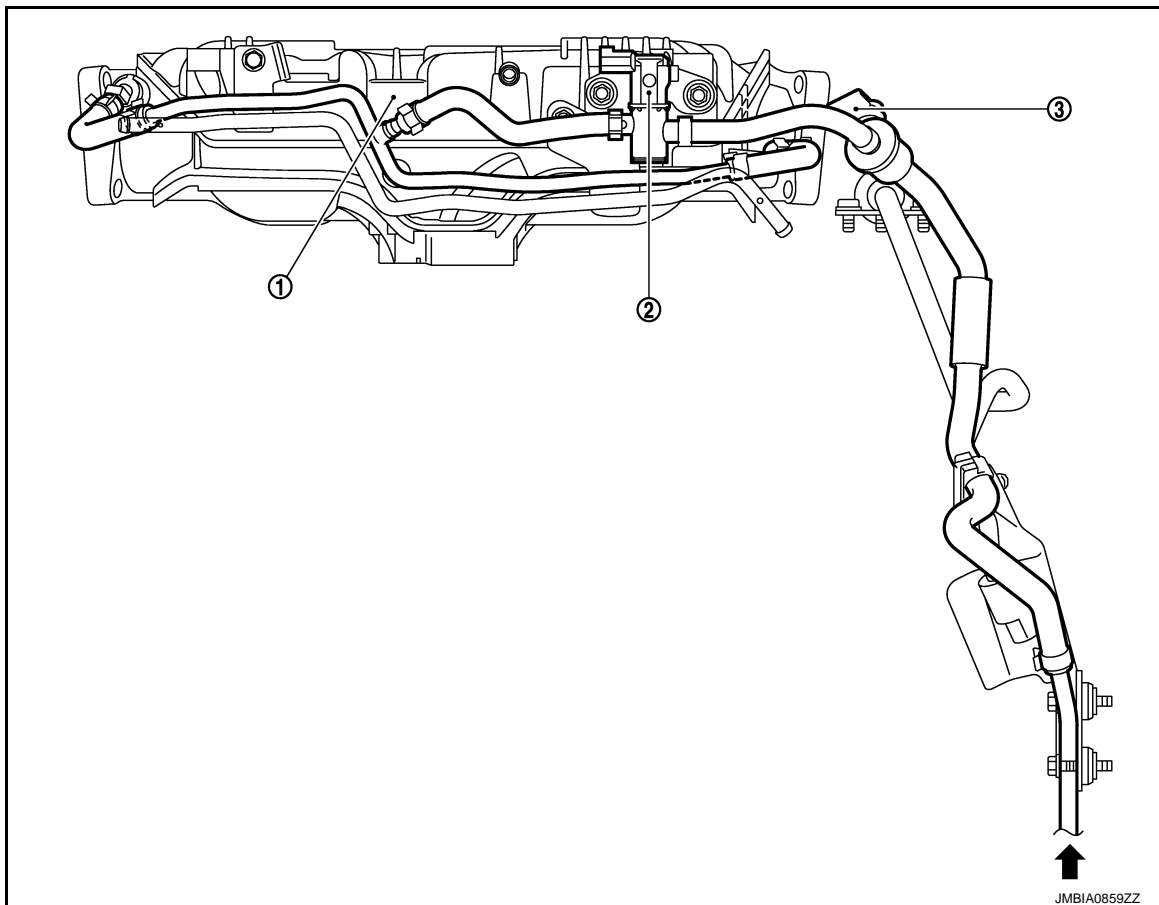

A
EC
C
D
E
F
G
H
I
J
K
L
M
N
O
P

EVAPORATIVE EMISSION SYSTEM

[VQ37VHR]

< SYSTEM DESCRIPTION >

1. Intake manifold collector
2. EVAP canister purge volume control
3. EVAP service port solenoid valve

← : From next figure

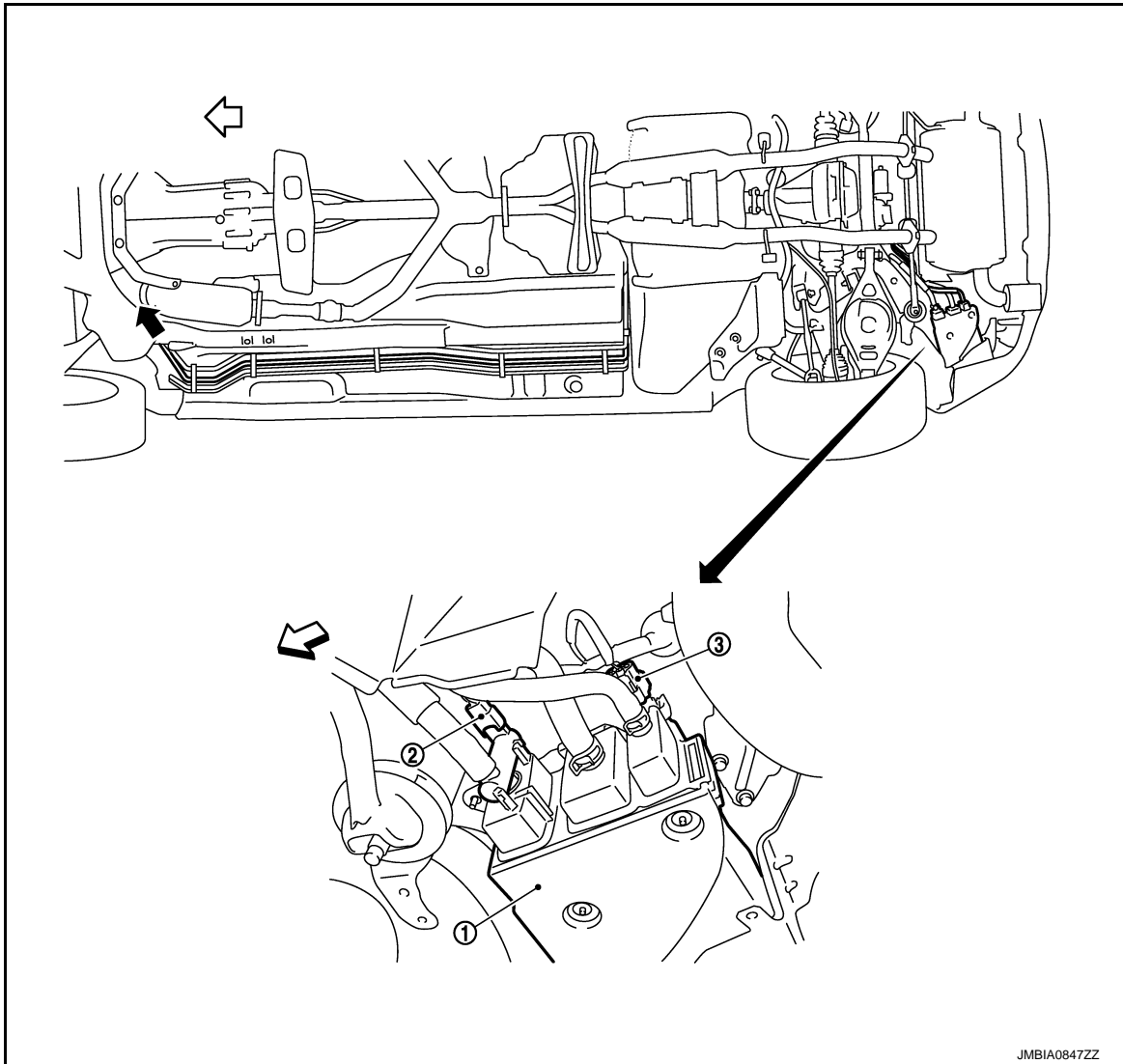

↔ : Vehicle front

1. EVAP canister
2. EVAP canister vent control valve
3. EVAP control system pressure sensor

← : To previous figure

NOTE:

Do not use soapy water or any type of solvent while installing vacuum hose or purge hoses.

EVAPORATIVE EMISSION SYSTEM

< SYSTEM DESCRIPTION >

[VQ37VHR]

Component Parts Location

INFOID:000000005151669

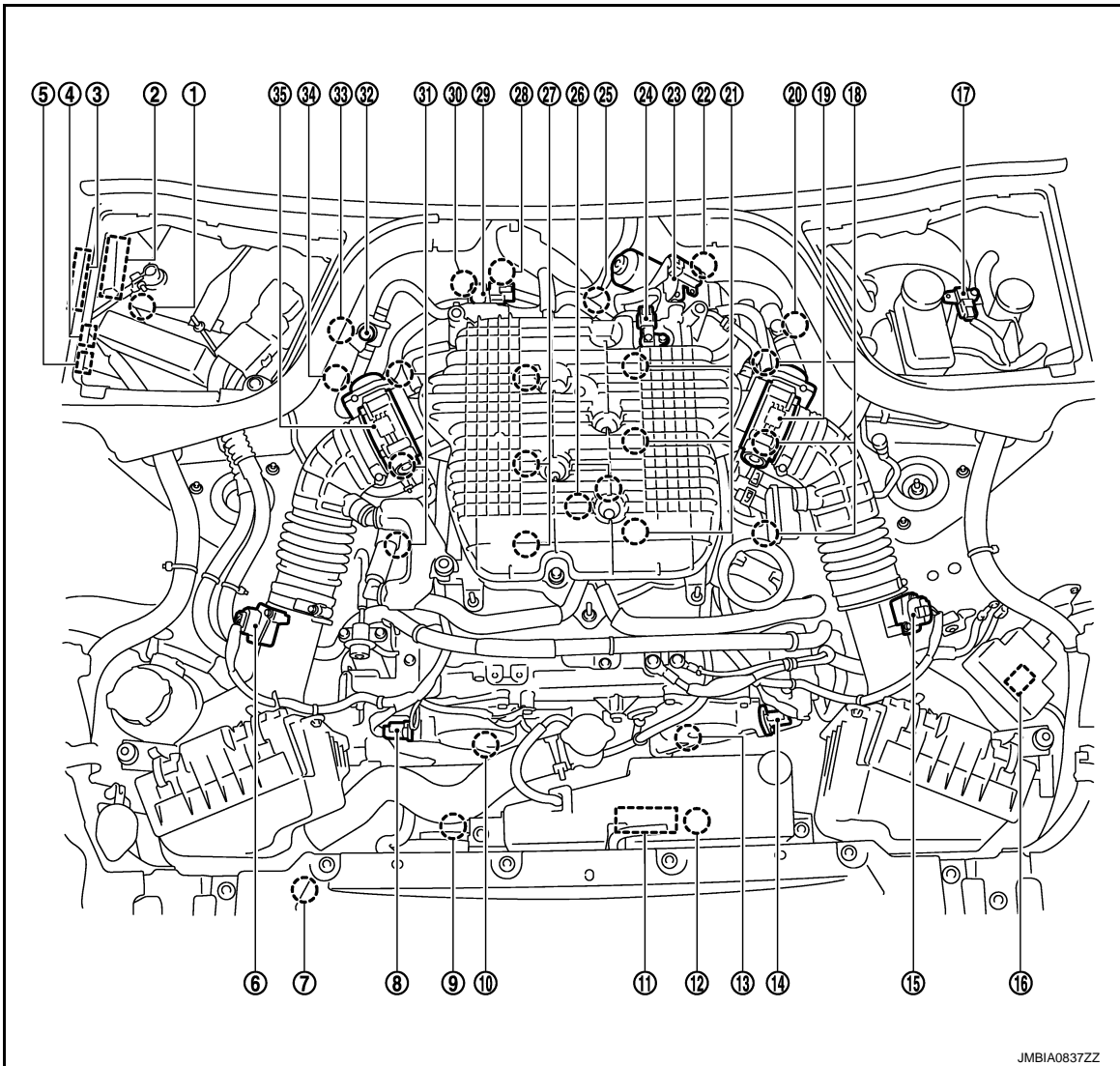

- | | | |
|---|---|---|
| 1. Battery current sensor | 2. IPDM E/R | 3. VVEL control module |
| 4. Cooling fan relay | 5. VVEL actuator motor relay | 6. Mass air flow sensor (with intake air temperature sensor) (bank 1) |
| 7. Refrigerant pressure sensor | 8. Camshaft position sensor (PHASE) (bank 1) | 9. Cooling fan motor-2 |
| 10. Intake valve timing control solenoid valve (bank 1) | 11. Cooling fan control module | 12. Cooling fan motor-1 |
| 13. Intake valve timing control solenoid valve (bank 2) | 14. Camshaft position sensor (PHASE) (bank 2) | 15. Mass air flow sensor (bank 2) |
| 16. ICC brake hold relay (ICC models) | 17. Brake booster pressure sensor | 18. Ignition coil (with power transistor) and spark plug (bank 2) |
| 19. Electric throttle control actuator (bank 2) | 20. A/F sensor 1 (bank 2) | 21. Fuel injector (bank 2) |
| 22. VVEL control shaft position sensor (bank 2) | 23. VVEL actuator motor (bank 2) | 24. Manifold absolute pressure (MAP) sensor |
| 25. Engine coolant temperature sensor | 26. Knock sensor | 27. Fuel injector (bank 1) |
| 28. VVEL actuator motor (bank 1) | 29. EVAP canister purge volume control solenoid valve | 30. VVEL control shaft position sensor (bank 1) |

EVAPORATIVE EMISSION SYSTEM

[VQ37VHR]

< SYSTEM DESCRIPTION >

- | | | |
|---|---|---------------------------|
| 31. Ignition coil (with power transistor and spark plug (bank 1)) | 32. EVAP service port | 33. A/F sensor 1 (bank 1) |
| 34. Crankshaft position sensor (POS) | 35. Electric throttle control actuator (bank 1) | |

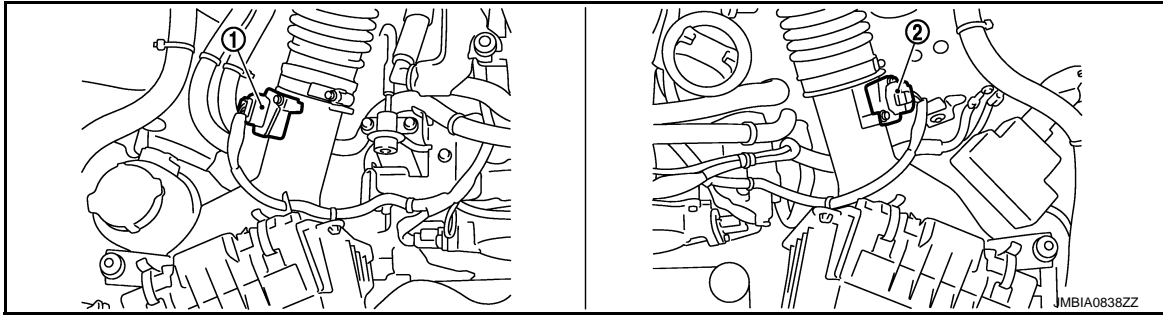

- | | |
|---|----------------------------------|
| 1. Mass air flow sensor (with intake air temperature sensor) (bank 1) | 2. Mass air flow sensor (bank 2) |
|---|----------------------------------|

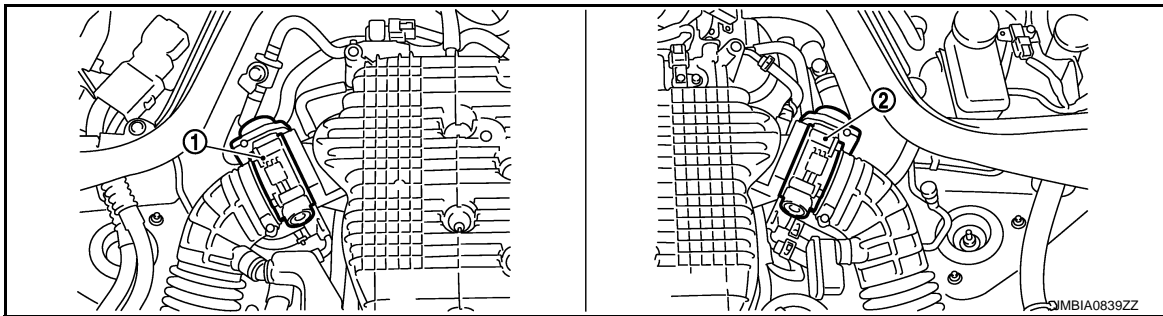

- | | |
|--|--|
| 1. Electric throttle control actuator (bank 1) | 2. Electric throttle control actuator (bank 2) |
|--|--|

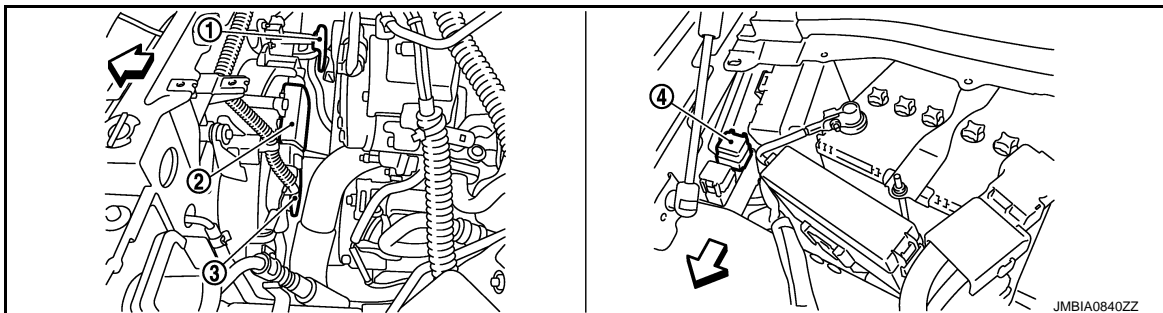

↙ : Vehicle front

- | | | |
|------------------------|-------------------------------|------------------------|
| 1. Cooling fan motor-2 | 2. Cooling fan control module | 3. Cooling fan motor-1 |
| 4. Cooling fan relay | | |

EVAPORATIVE EMISSION SYSTEM

< SYSTEM DESCRIPTION >

[VQ37VHR]

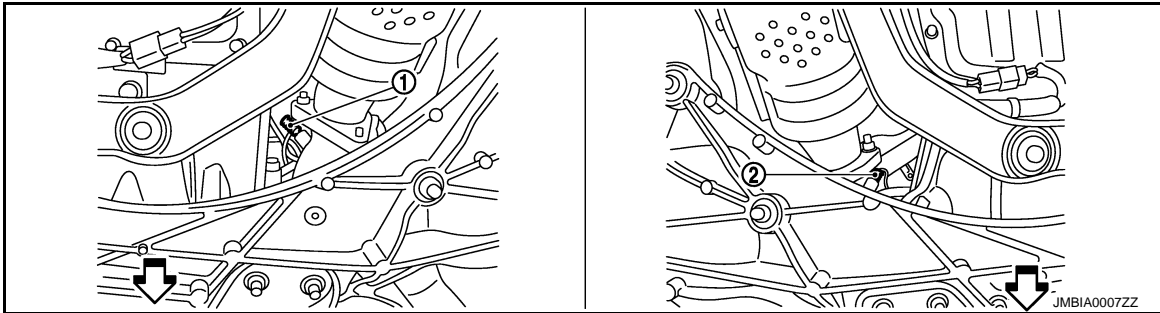
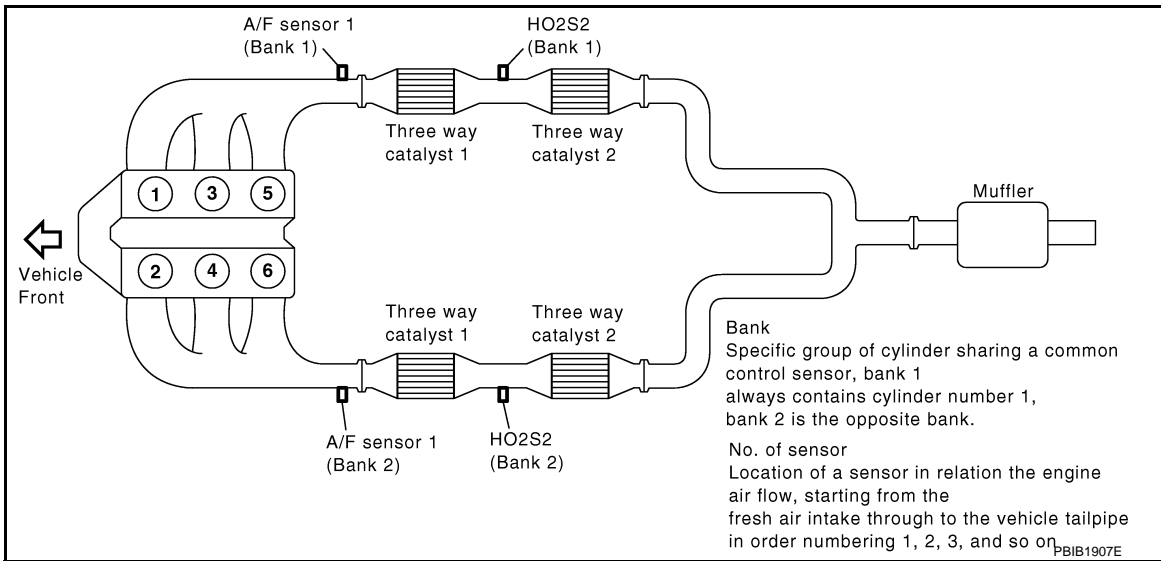

⇐: Vehicle front

1. A/F sensor 1 (bank 1)
2. A/F sensor 1 (bank 2)

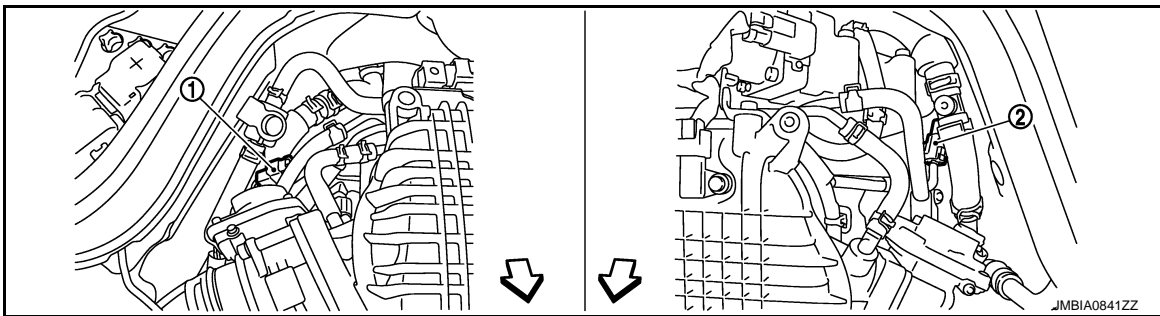

⇐: Vehicle front

1. A/F sensor 1 (bank 1) harness connector
2. A/F sensor 1 (bank 2) harness connector

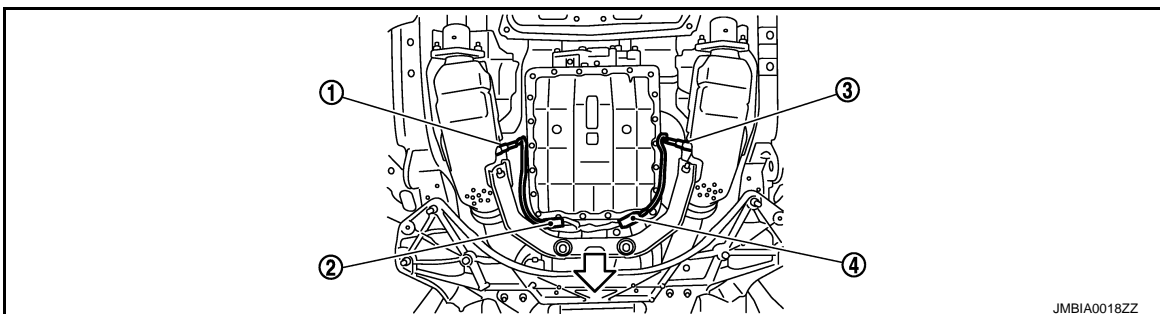

EVAPORATIVE EMISSION SYSTEM

[VQ37VHR]

< SYSTEM DESCRIPTION >

↖ : Vehicle front

1. Heated oxygen sensor 2 (bank 2)
2. Heated oxygen sensor 2 (bank 2)
3. Heated oxygen sensor 2 (bank 1) harness connector
4. Heated oxygen sensor 2 (bank 1) harness connector

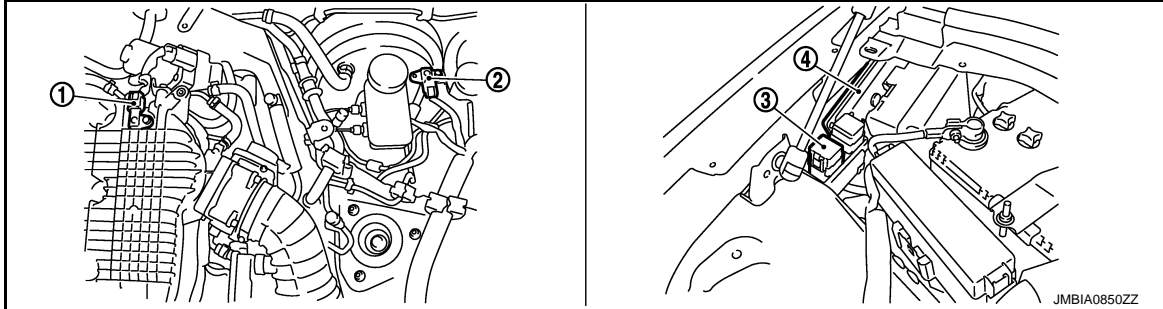

1. Manifold absolute pressure (MAP) sensor
2. Brake booster pressure sensor
3. VVEL actuator motor relay
4. VVEL control module



↖ : Vehicle front

1. VVEL control shaft position sensor (bank 1)
2. VVEL actuator motor (bank 1)
3. VVEL actuator motor (bank 2)
4. VVEL control shaft position sensor (bank 2)

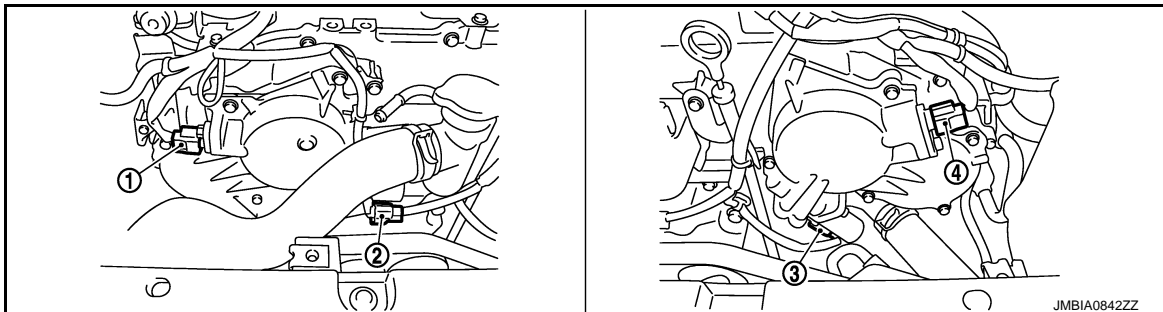

1. Camshaft position sensor (PHASE) (bank 1)
2. Intake valve timing control solenoid valve (bank 1) harness connector
3. Intake valve timing control solenoid valve (bank 2) harness connector
4. Camshaft position sensor (PHASE) (bank 2)

EVAPORATIVE EMISSION SYSTEM

< SYSTEM DESCRIPTION >

[VQ37VHR]

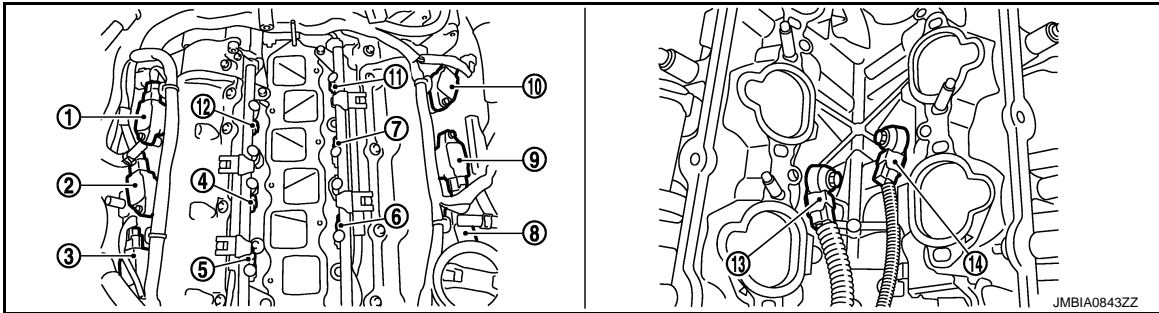

- | | | |
|--|---|---|
| 1. Ignition coil No.5 (with power transistor) | 2. Ignition coil No.3 (with power transistor) | 3. Ignition coil No.1 (with power transistor) |
| 4. Fuel injector No.3 | 5. Fuel injector No.1 | 6. Fuel injector No.2 |
| 7. Fuel injector No.4 | 8. Ignition coil No.2 (with power transistor) | 9. Ignition coil No.4 (with power transistor) |
| 10. Ignition coil No.6 (with power transistor) | 11. Fuel injector No.6 | 12. Fuel injector No.5 |
| 13. Knock sensor (bank 1) | 14. Knock sensor (bank 2) | |

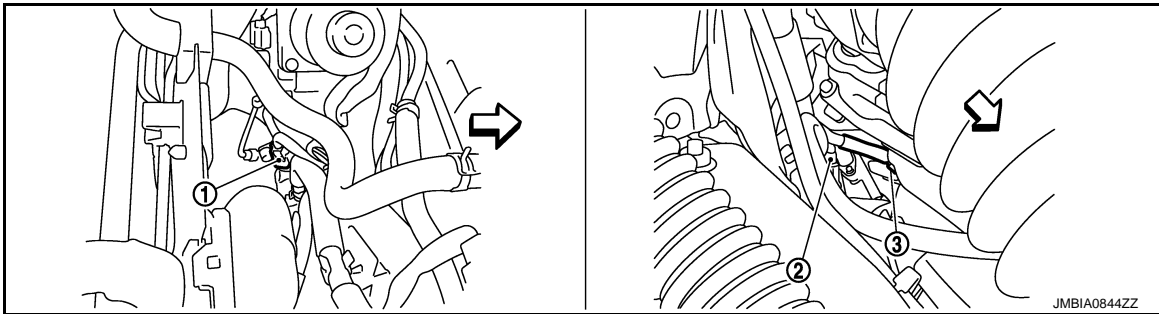

↶ : Vehicle front

- | | | |
|--------------------------------------|--------------------------|-------------------------------------|
| 1. Engine coolant temperature sensor | 2. A/F sensor 1 (bank 1) | 3. Crankshaft position sensor (POS) |
|--------------------------------------|--------------------------|-------------------------------------|

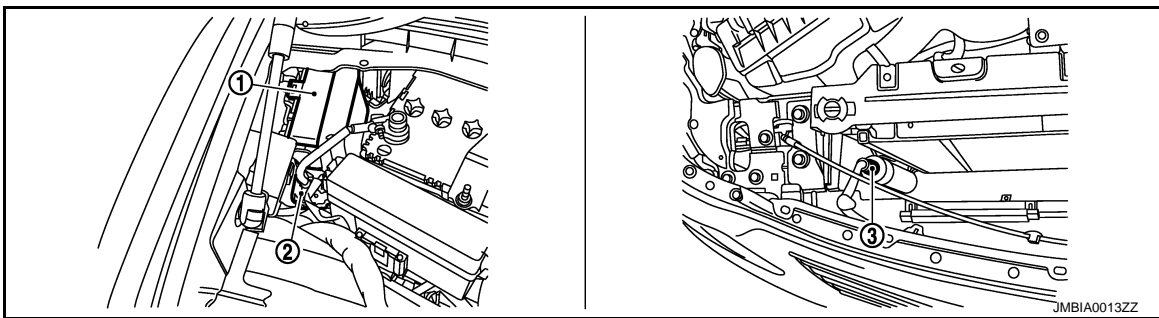

- | | | |
|-------------|---------------------------|--------------------------------|
| 1. IPDM E/R | 2. Battery current sensor | 3. Refrigerant pressure sensor |
|-------------|---------------------------|--------------------------------|

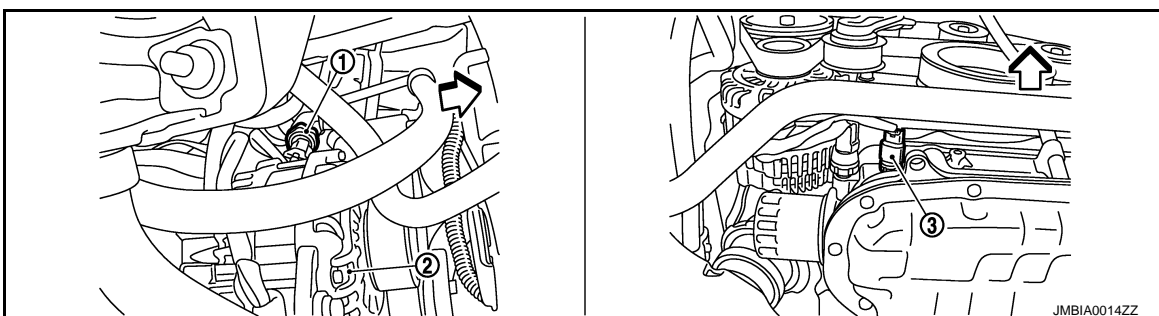

A
EC
C
D
E
F
G
H
I
J
K
L
M
N
O
P

EVAPORATIVE EMISSION SYSTEM

[VQ37VHR]

< SYSTEM DESCRIPTION >

↶ : Vehicle front

1. Power steering pressure sensor 2. Alternator 3. Engine oil temperature sensor

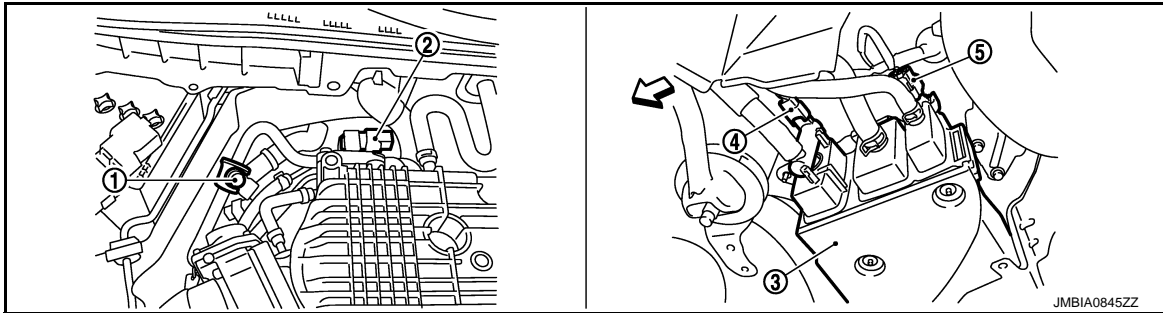

↶ : Vehicle front

1. EVAP service port 2. EVAP canister purge volume control 3. EVAP canister solenoid valve
4. EVAP canister vent control valve 5. EVAP control system pressure sensor

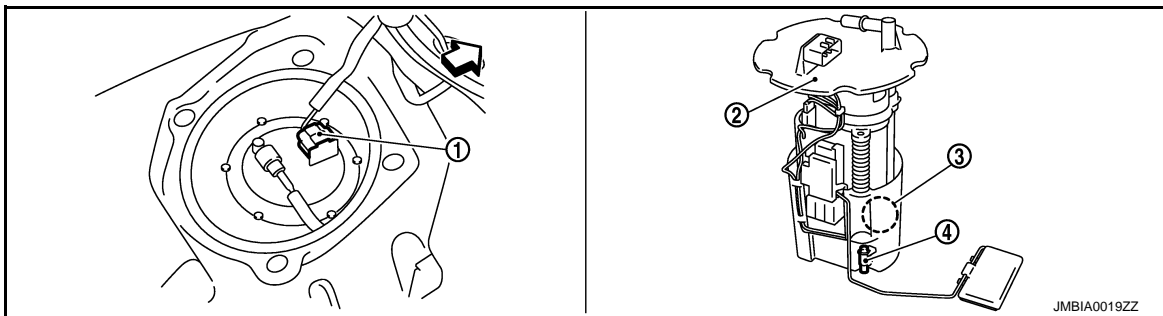

↶ : Vehicle front

1. Fuel level sensor unit and fuel pump 2. Fuel level sensor unit and fuel pump 3. Fuel pressure regulator harness connector
4. Fuel tank temperature sensor

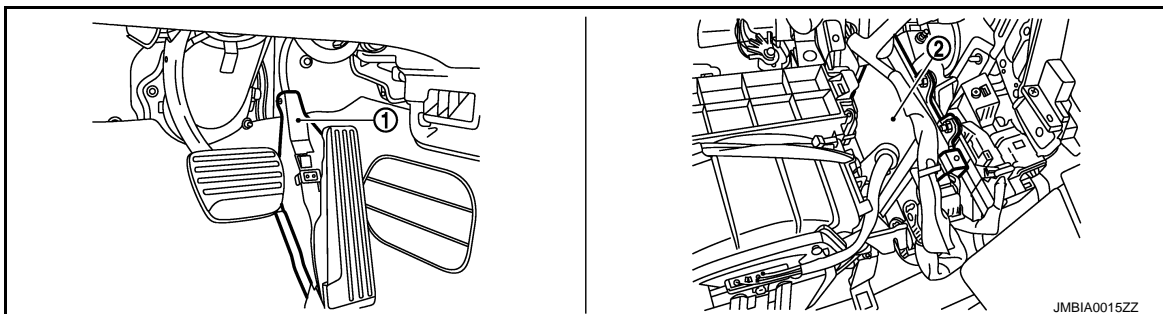

1. Accelerator pedal position sensor 2. ECM

EVAPORATIVE EMISSION SYSTEM

< SYSTEM DESCRIPTION >

[VQ37VHR]

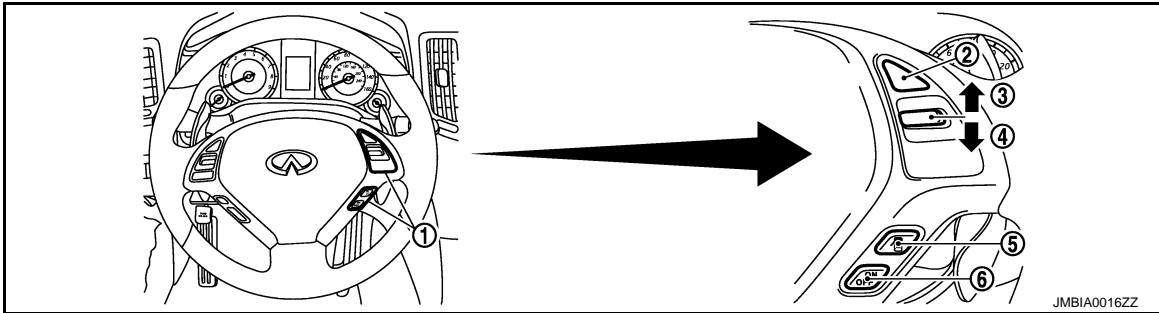

- | | | |
|------------------------|--------------------|-----------------------------|
| 1. ICC steering switch | 2. CANCEL switch | 3. RESUME/ACCELERATE switch |
| 4. SET/COAST switch | 5. DISTANCE switch | 6. MAIN switch |

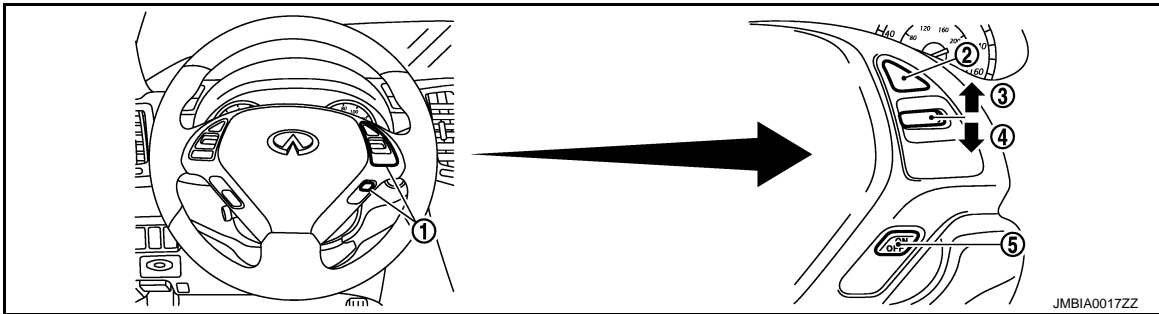

- | | | |
|-------------------------|------------------|-----------------------------|
| 1. ASCD steering switch | 2. CANCEL switch | 3. RESUME/ACCELERATE switch |
| 4. SET/COAST switch | 5. MAIN switch | |

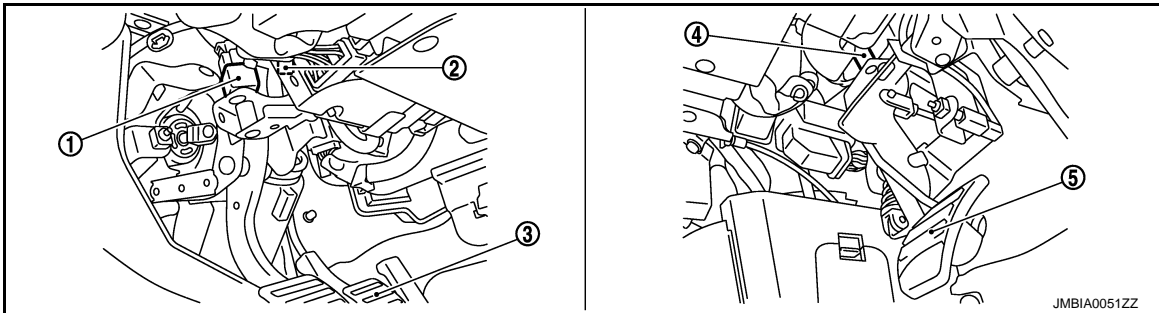

- | | | |
|---|---|----------------|
| 1. Stop lamp switch | 2. ASCD brake switch (ASCD models)
ICC brake switch (ICC models) | 3. Brake pedal |
| 4. ASCD clutch switch (ASCD models)
ICC clutch switch (ICC models) | 5. Clutch pedal | |

Component Description

INFOID:000000005151670

Component	Reference
A/F sensor 1	EC-201, "Description"
Accelerator pedal position sensor	EC-463, "Description"
Camshaft position sensor (PHASE)	EC-273, "Description"
Crankshaft position sensor (POS)	EC-269, "Description"
Engine coolant temperature sensor	EC-187, "Description"
EVAP canister purge volume control solenoid valve	EC-293, "Description"
EVAP control system pressure sensor	EC-309, "Description"

EVAPORATIVE EMISSION SYSTEM

[VQ37VHR]

< SYSTEM DESCRIPTION >

Component	Reference
Fuel tank temperature sensor	EC-244. "Description"
Mass air flow sensor	EC-165. "Description"
Throttle position sensor	EC-190. "Description"

INTAKE VALVE TIMING CONTROL

< SYSTEM DESCRIPTION >

[VQ37VHR]

INTAKE VALVE TIMING CONTROL

System Diagram

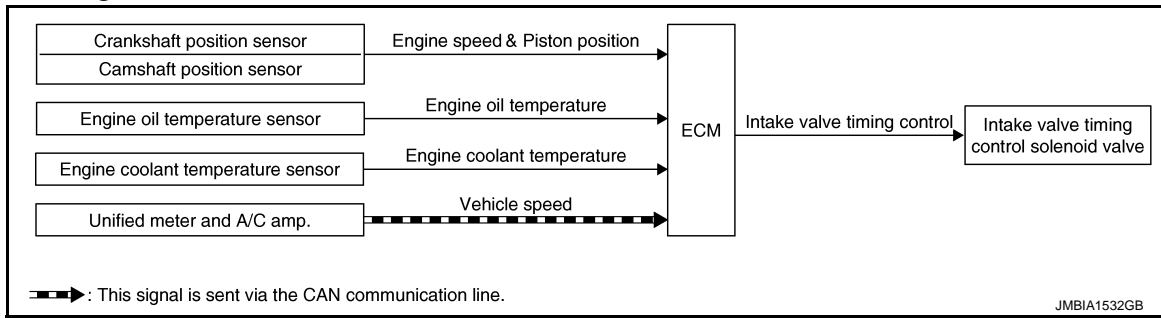

System Description

INFOID:000000005151672

INPUT/OUTPUT SIGNAL CHART

Sensor	Input signal to ECM	ECM function	Actuator
Crankshaft position sensor (POS)	Engine speed and piston position	Intake valve timing control	Intake valve timing control solenoid valve
Camshaft position sensor (PHASE)			
Engine coolant temperature sensor	Engine coolant temperature		
Engine oil temperature sensor	Engine oil temperature		
Unified meter and A/C amp.	Vehicle speed*		

*: This signal is sent to the ECM via the CAN communication line

SYSTEM DESCRIPTION

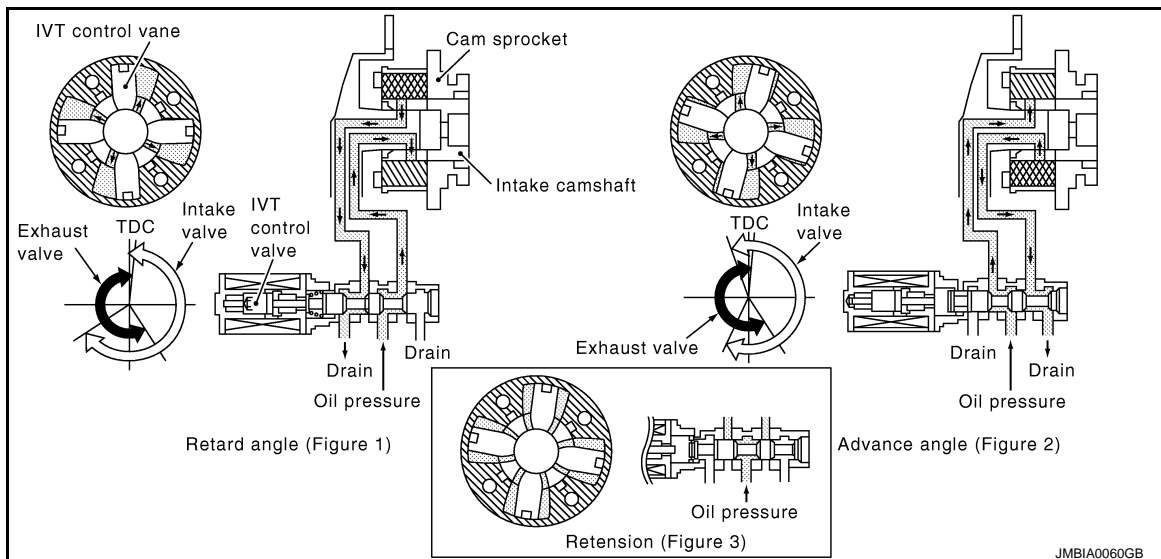

This mechanism hydraulically controls cam phases continuously with the fixed operating angle of the intake valve.

The ECM receives signals such as crankshaft position, camshaft position, vehicle speed, engine coolant temperature and engine oil temperature. Then, the ECM sends ON/OFF pulse duty signals to the intake valve timing (IVT) control solenoid valve depending on driving status. This makes it possible to control the shut/open timing of the intake valve to increase engine torque in low/mid speed range and output in high-speed range.

INTAKE VALVE TIMING CONTROL

< SYSTEM DESCRIPTION >

[VQ37VHR]

Component Parts Location

INFOID:000000005151673

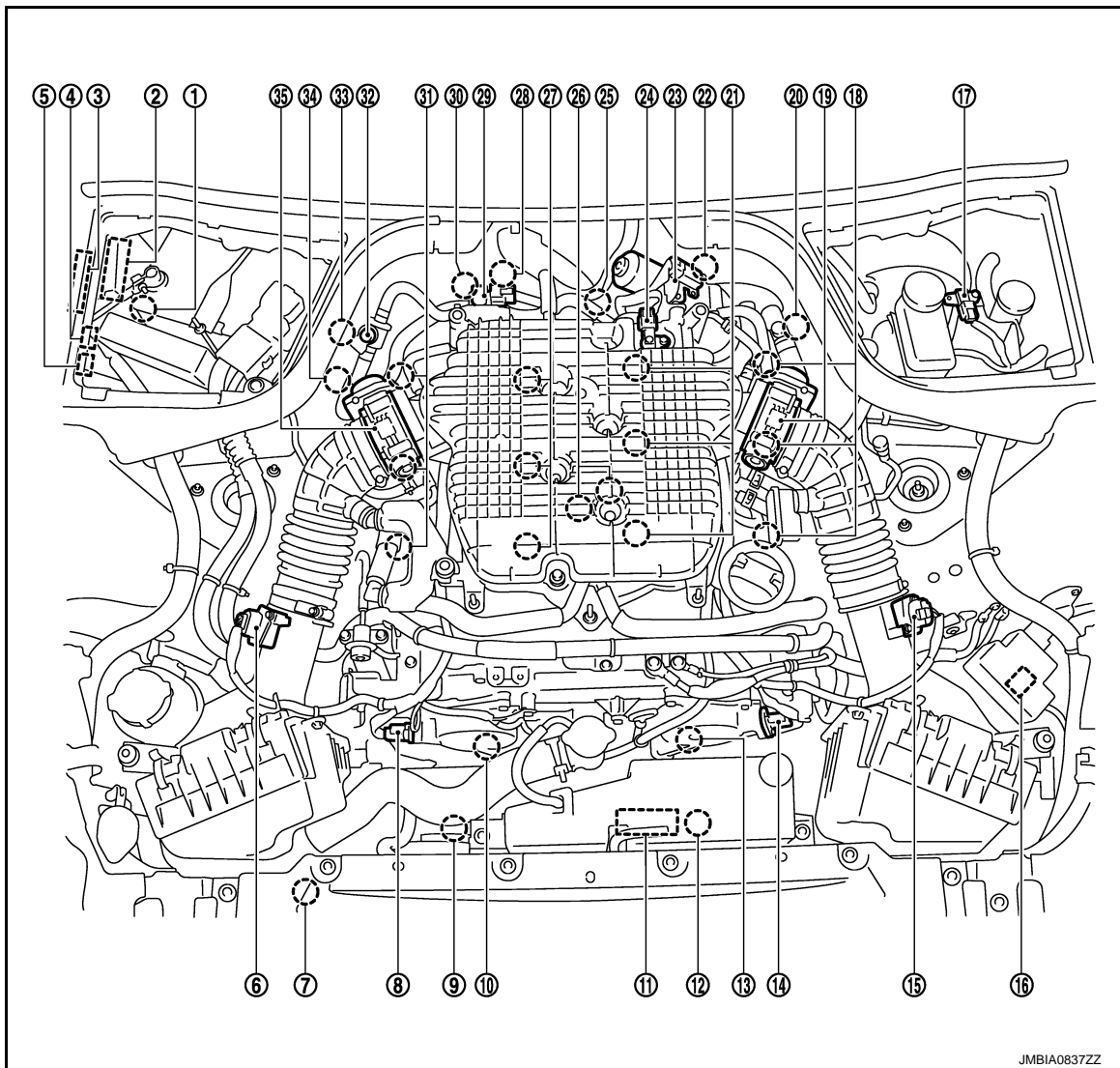

JMBIA0837ZZ

- | | | |
|---|---|---|
| 1. Battery current sensor | 2. IPDM E/R | 3. VVEL control module |
| 4. Cooling fan relay | 5. VVEL actuator motor relay | 6. Mass air flow sensor (with intake air temperature sensor) (bank 1) |
| 7. Refrigerant pressure sensor | 8. Camshaft position sensor (PHASE) (bank 1) | 9. Cooling fan motor-2 |
| 10. Intake valve timing control solenoid valve (bank 1) | 11. Cooling fan control module | 12. Cooling fan motor-1 |
| 13. Intake valve timing control solenoid valve (bank 2) | 14. Camshaft position sensor (PHASE) (bank 2) | 15. Mass air flow sensor (bank 2) |
| 16. ICC brake hold relay (ICC models) | 17. Brake booster pressure sensor | 18. Ignition coil (with power transistor and spark plug) (bank 2) |
| 19. Electric throttle control actuator (bank 2) | 20. A/F sensor 1 (bank 2) | 21. Fuel injector (bank 2) |
| 22. VVEL control shaft position sensor (bank 2) | 23. VVEL actuator motor (bank 2) | 24. Manifold absolute pressure (MAP) sensor |
| 25. Engine coolant temperature sensor | 26. Knock sensor | 27. Fuel injector (bank 1) |
| 28. VVEL actuator motor (bank 1) | 29. EVAP canister purge volume control solenoid valve | 30. VVEL control shaft position sensor (bank 1) |

INTAKE VALVE TIMING CONTROL

[VQ37VHR]

< SYSTEM DESCRIPTION >

- | | | |
|---|---|---------------------------|
| 31. Ignition coil (with power transistor and spark plug (bank 1)) | 32. EVAP service port | 33. A/F sensor 1 (bank 1) |
| 34. Crankshaft position sensor (POS) | 35. Electric throttle control actuator (bank 1) | |

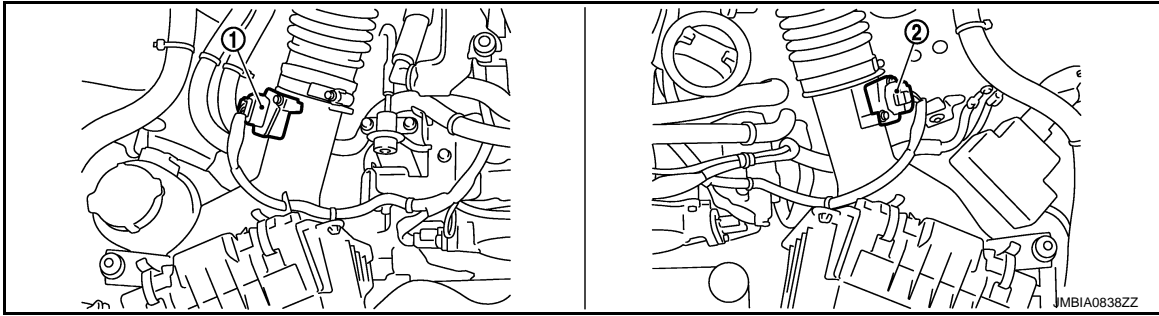

- | | |
|---|----------------------------------|
| 1. Mass air flow sensor (with intake air temperature sensor) (bank 1) | 2. Mass air flow sensor (bank 2) |
|---|----------------------------------|

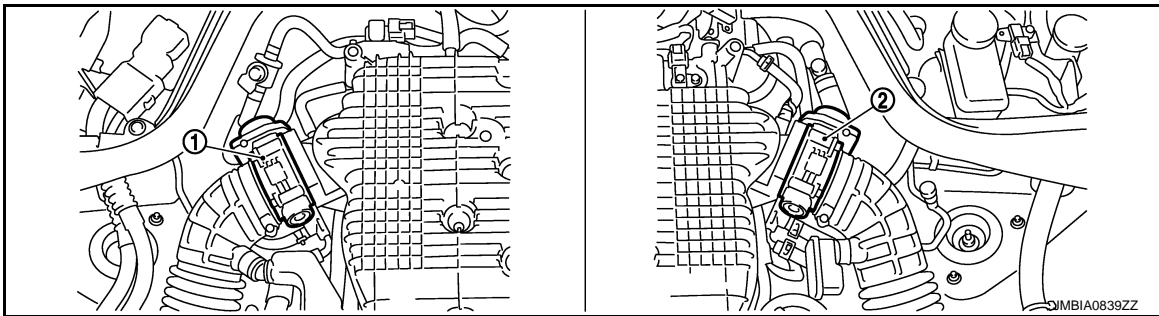

- | | |
|--|--|
| 1. Electric throttle control actuator (bank 1) | 2. Electric throttle control actuator (bank 2) |
|--|--|

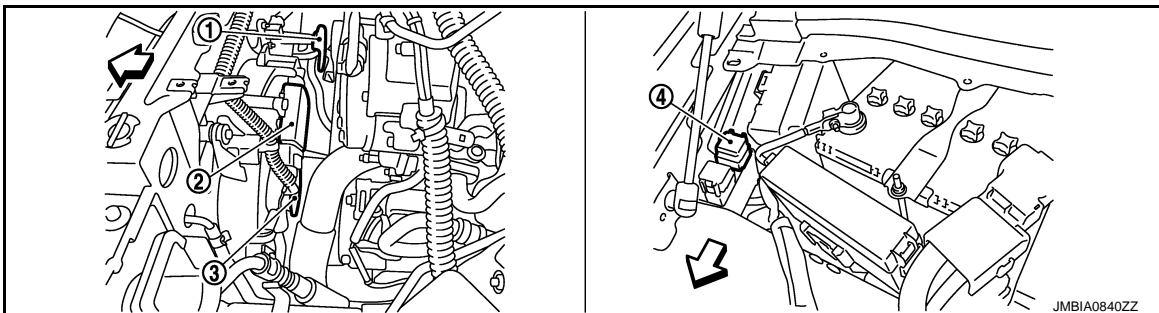

↔ : Vehicle front

- | | | |
|------------------------|-------------------------------|------------------------|
| 1. Cooling fan motor-2 | 2. Cooling fan control module | 3. Cooling fan motor-1 |
| 4. Cooling fan relay | | |

A
EC
C
D
E
F
G
H
I
J
K
L
M
N
O
P

INTAKE VALVE TIMING CONTROL

< SYSTEM DESCRIPTION >

[VQ37VHR]

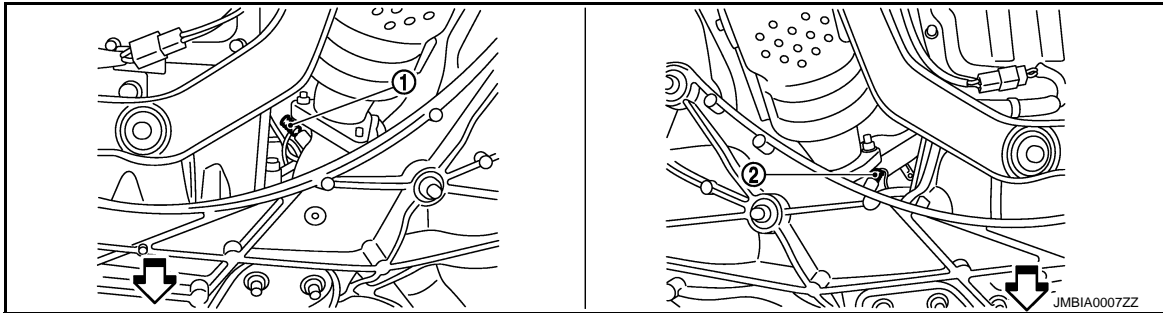
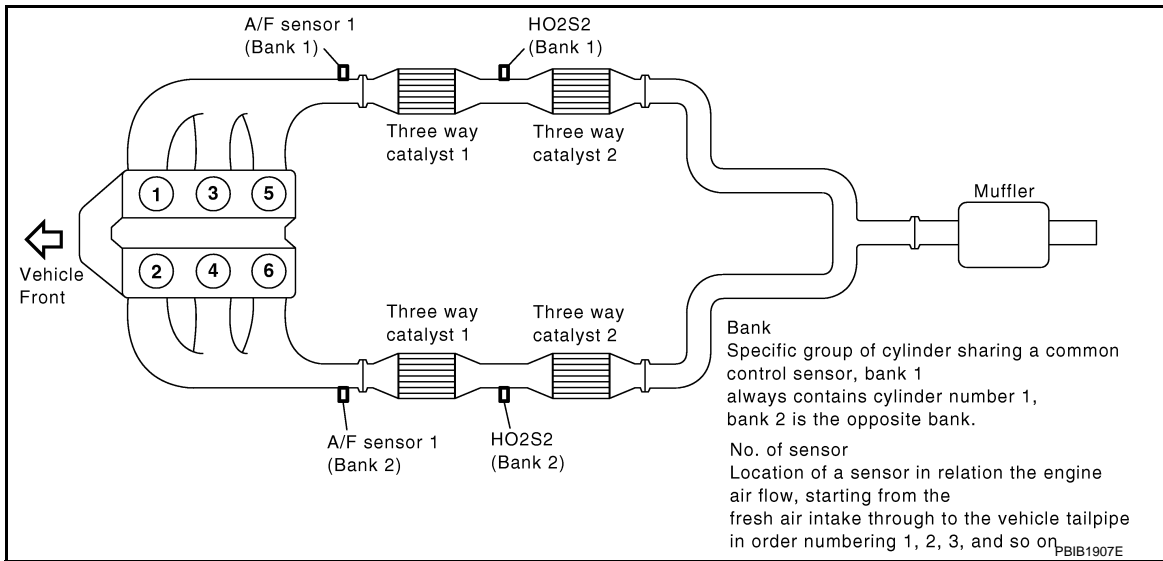

← : Vehicle front

1. A/F sensor 1 (bank 1)
2. A/F sensor 1 (bank 2)

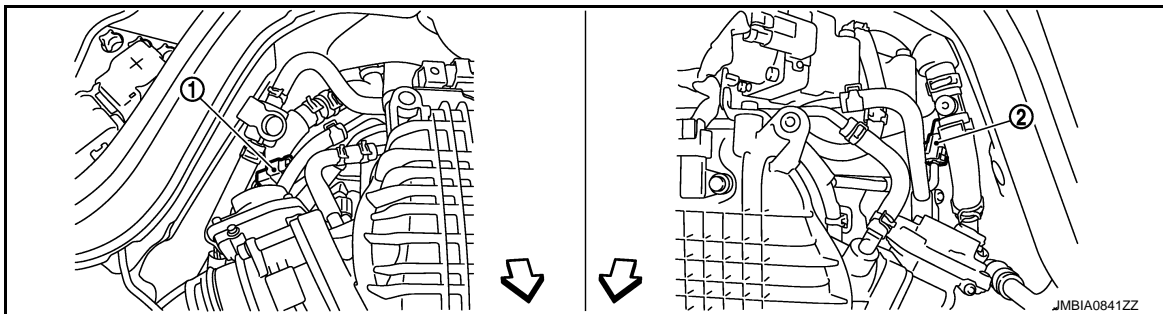

← : Vehicle front

1. A/F sensor 1 (bank 1) harness connector
2. A/F sensor 1 (bank 2) harness connector

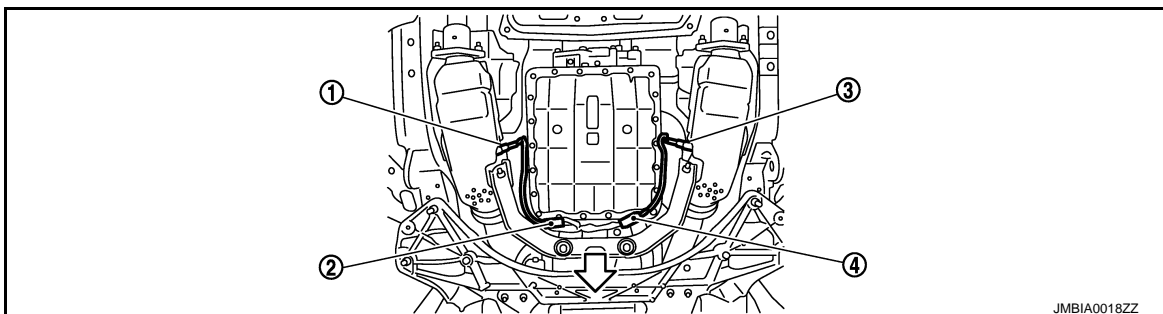

INTAKE VALVE TIMING CONTROL

[VQ37VHR]

< SYSTEM DESCRIPTION >

↶: Vehicle front

1. Heated oxygen sensor 2 (bank 2)
2. Heated oxygen sensor 2 (bank 2) harness connector
3. Heated oxygen sensor 2 (bank 1)
4. Heated oxygen sensor 2 (bank 1) harness connector

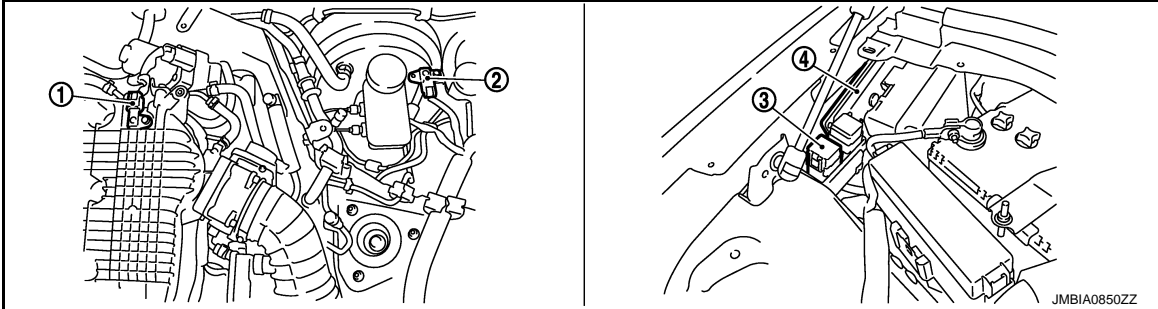

1. Manifold absolute pressure (MAP) sensor
2. Brake booster pressure sensor
3. VVEL actuator motor relay
4. VVEL control module



↶: Vehicle front

1. VVEL control shaft position sensor (bank 1)
2. VVEL actuator motor (bank 1)
3. VVEL actuator motor (bank 2)
4. VVEL control shaft position sensor (bank 2)

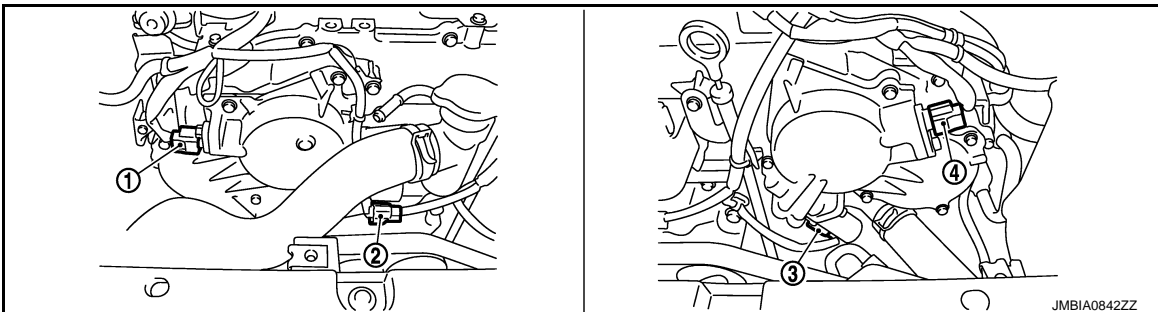

1. Camshaft position sensor (PHASE) (bank 1)
2. Intake valve timing control solenoid valve (bank 1) harness connector
3. Intake valve timing control solenoid valve (bank 2) harness connector
4. Camshaft position sensor (PHASE) (bank 2)

A
EC
C
D
E
F
G
H
I
J
K
L
M
N
O
P

INTAKE VALVE TIMING CONTROL

< SYSTEM DESCRIPTION >

[VQ37VHR]

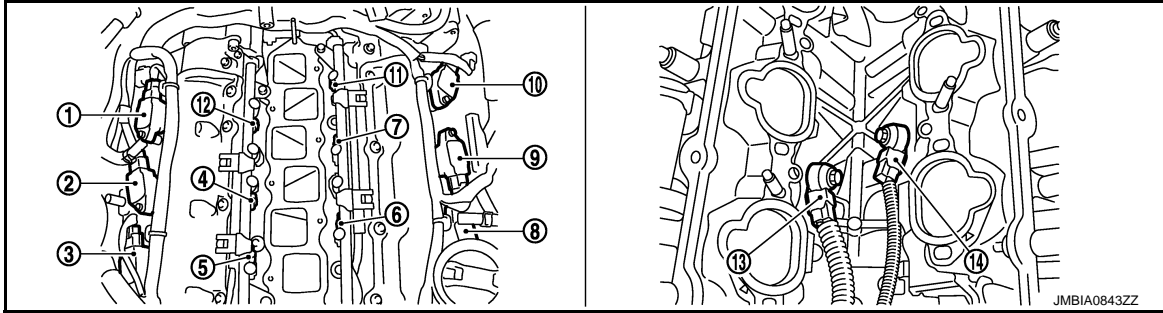

- | | | |
|--|---|---|
| 1. Ignition coil No.5 (with power transistor) | 2. Ignition coil No.3 (with power transistor) | 3. Ignition coil No.1 (with power transistor) |
| 4. Fuel injector No.3 | 5. Fuel injector No.1 | 6. Fuel injector No.2 |
| 7. Fuel injector No.4 | 8. Ignition coil No.2 (with power transistor) | 9. Ignition coil No.4 (with power transistor) |
| 10. Ignition coil No.6 (with power transistor) | 11. Fuel injector No.6 | 12. Fuel injector No.5 |
| 13. Knock sensor (bank 1) | 14. Knock sensor (bank 2) | |

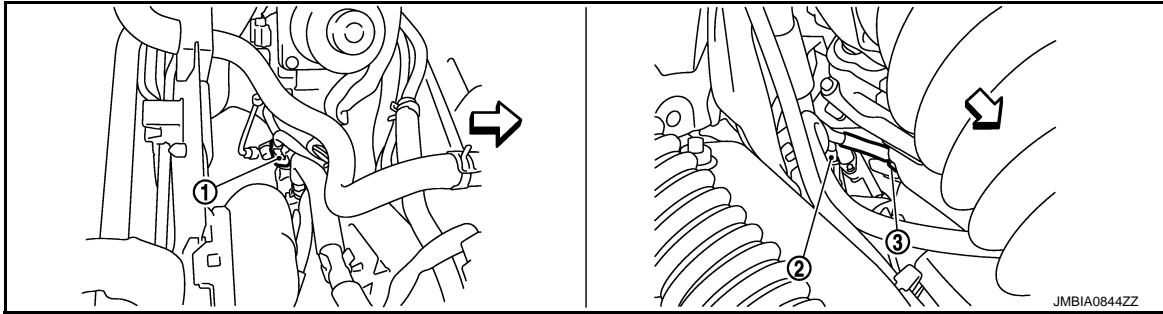

← : Vehicle front

- | | | |
|--------------------------------------|--------------------------|-------------------------------------|
| 1. Engine coolant temperature sensor | 2. A/F sensor 1 (bank 1) | 3. Crankshaft position sensor (POS) |
|--------------------------------------|--------------------------|-------------------------------------|

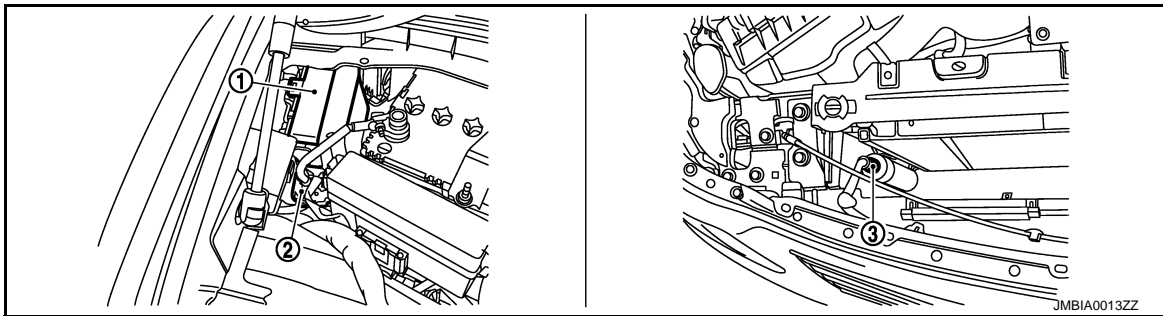

- | | | |
|-------------|---------------------------|--------------------------------|
| 1. IPDM E/R | 2. Battery current sensor | 3. Refrigerant pressure sensor |
|-------------|---------------------------|--------------------------------|

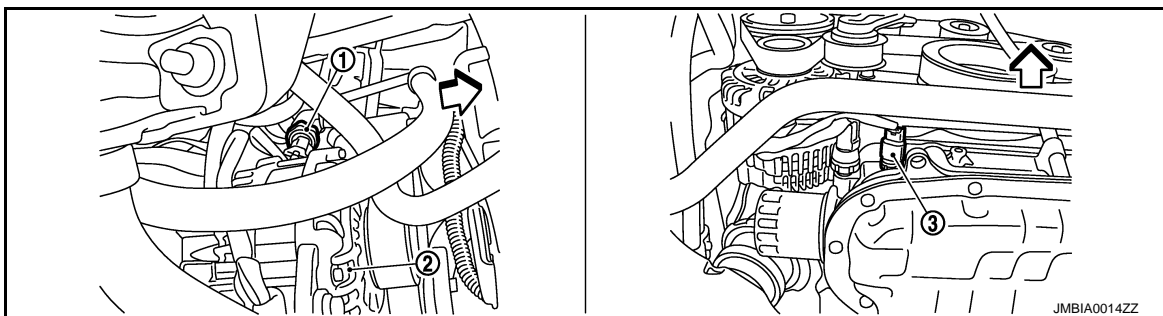

INTAKE VALVE TIMING CONTROL

[VQ37VHR]

< SYSTEM DESCRIPTION >

↔: Vehicle front

- 1. Power steering pressure sensor 2. Alternator 3. Engine oil temperature sensor

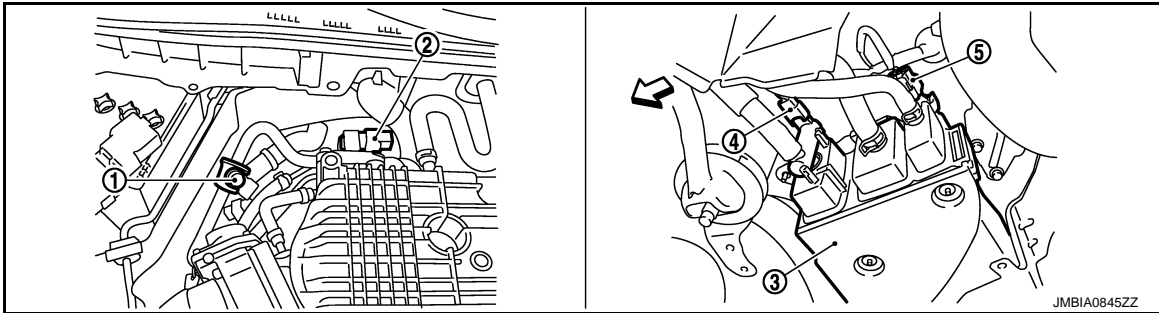

↔: Vehicle front

- 1. EVAP service port 2. EVAP canister purge volume control 3. EVAP canister solenoid valve
- 4. EVAP canister vent control valve 5. EVAP control system pressure sensor

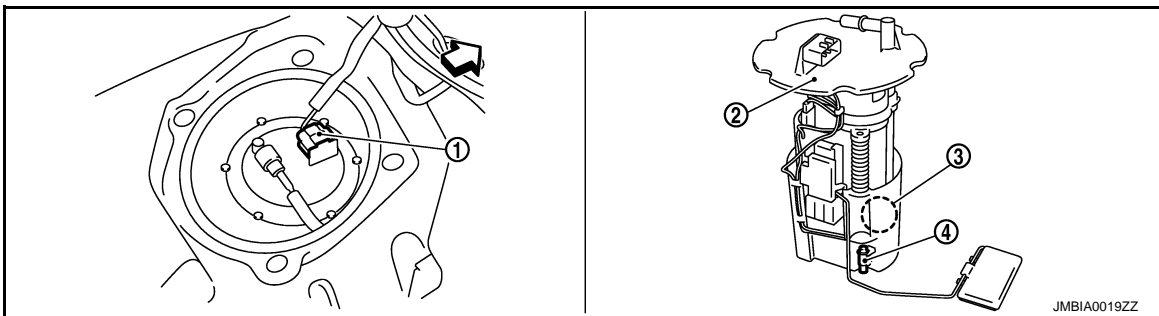

↔: Vehicle front

- 1. Fuel level sensor unit and fuel pump 2. Fuel level sensor unit and fuel pump harness connector 3. Fuel pressure regulator
- 4. Fuel tank temperature sensor

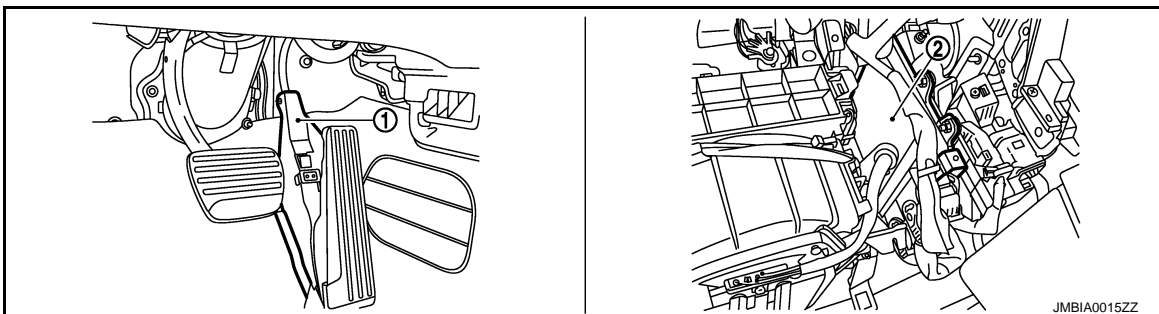

- 1. Accelerator pedal position sensor 2. ECM

A
EC
C
D
E
F
G
H
I
J
K
L
M
N
O
P

INTAKE VALVE TIMING CONTROL

< SYSTEM DESCRIPTION >

[VQ37VHR]

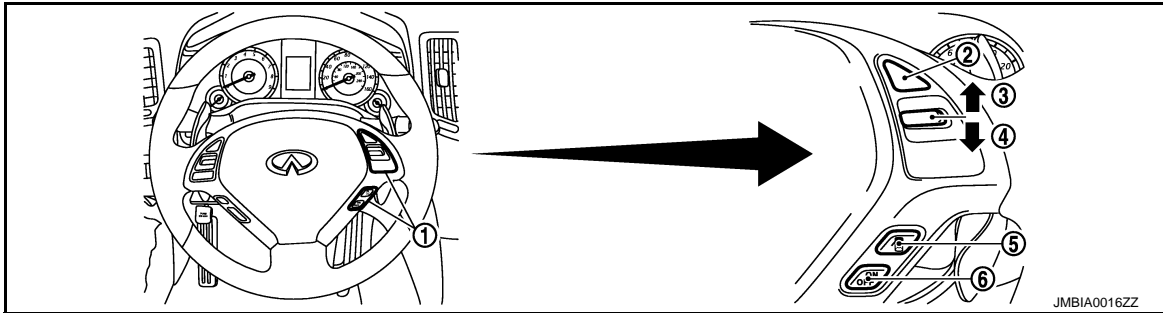

- 1. ICC steering switch
- 2. CANCEL switch
- 3. RESUME/ACCELERATE switch
- 4. SET/COAST switch
- 5. DISTANCE switch
- 6. MAIN switch

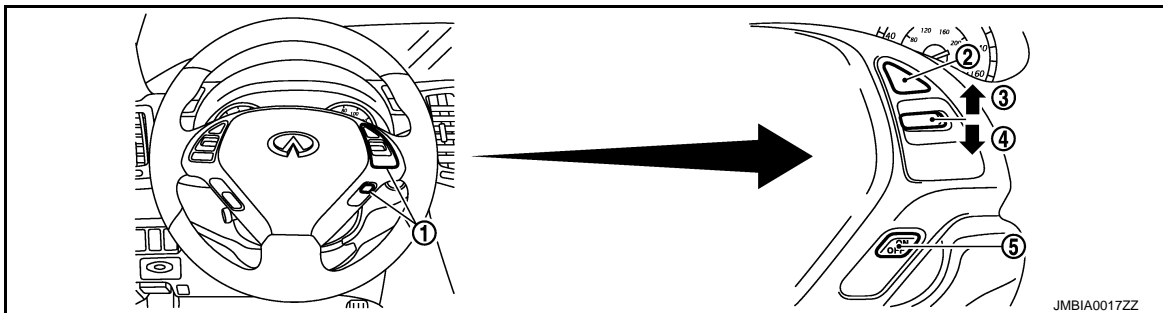

- 1. ASCD steering switch
- 2. CANCEL switch
- 3. RESUME/ACCELERATE switch
- 4. SET/COAST switch
- 5. MAIN switch

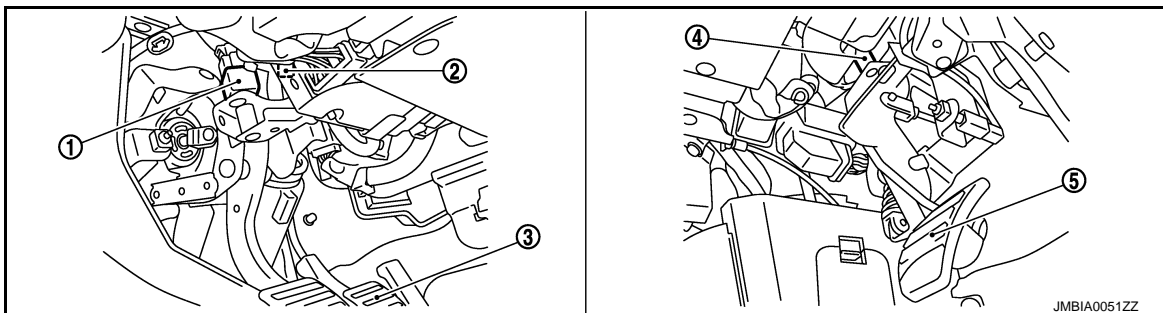

- 1. Stop lamp switch
- 2. ASCD brake switch (ASCD models)
ICC brake switch (ICC models)
- 3. Brake pedal
- 4. ASCD clutch switch (ASCD models)
ICC clutch switch (ICC models)
- 5. Clutch pedal

Component Description

INFOID:000000005151674

Component	Reference
Camshaft position sensor (PHASE)	EC-273. "Description"
Crankshaft position sensor (POS)	EC-269. "Description"
Engine coolant temperature sensor	EC-187. "Description"
Engine coolant temperature sensor	EC-185. "Description"
Intake valve timing control solenoid valve	EC-162. "Description"

VVEL SYSTEM

< SYSTEM DESCRIPTION >

[VQ37VHR]

VVEL SYSTEM

System Diagram

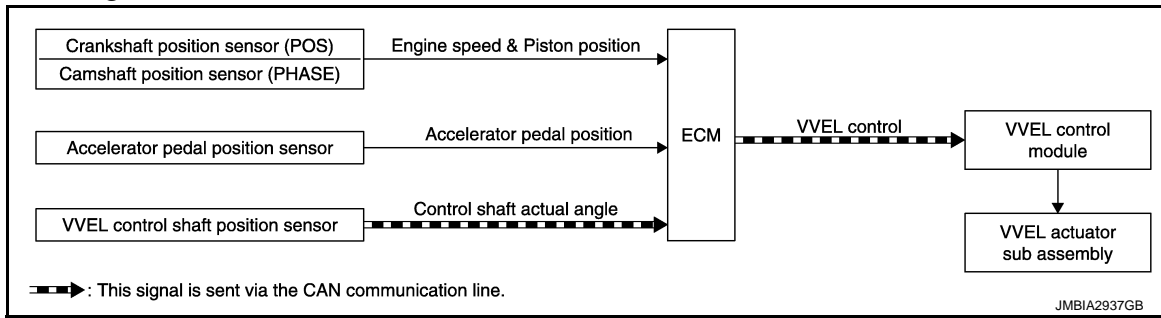

System Description

INFOID:000000005151676

INPUT/OUTPUT SIGNAL CHART

Sensor	Input signal to ECM	ECM function	Actuator
Crankshaft position sensor (POS)	Engine speed and piston position	VVEL control	VVEL control module ↓ VVEL actuator sub assembly
Camshaft position sensor (PHASE)			
Accelerator pedal position sensor	Accelerator pedal position		
VVEL control shaft position sensor	Control shaft actual angle*		

*: This signal is sent to the ECM via the CAN communication line

SYSTEM DESCRIPTION

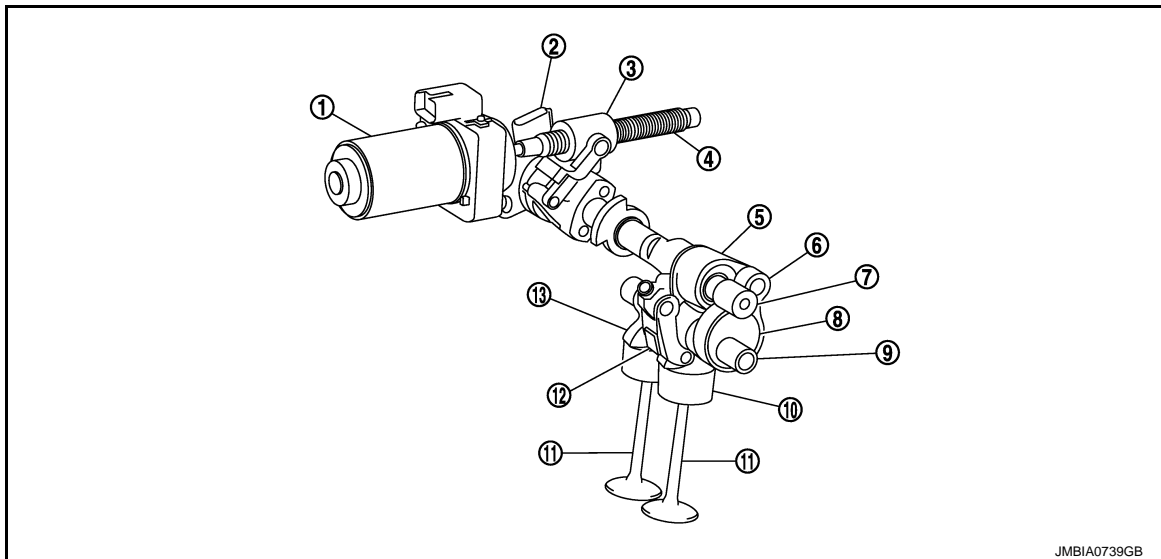

- | | | |
|------------------------|---------------------------------------|-------------------|
| 1. VVEL actuator motor | 2. VVEL control shaft position sensor | 3. Ball screw nut |
| 4. Ball screw shaft | 5. Rocker arm | 6. Link A |
| 7. Control shaft | 8. Eccentric cam | 9. Drive shaft |
| 10. Valve lifter | 11. Intake valve | 12. Link B |
| 13. Output cam | | |

VVEL (Variable Valve Event & Lift) is a system that controls valve event and valve lift continuously. Rotational movement of the drive shaft equipped with eccentric cam is transmitted to output cam via the rocker arm and two kinds of links to depress the intake valve. ECM decides the target valve lift according to the driving condition and sends the command signal to the VVEL control module. The VVEL control module controls the rotation of the control shaft using the VVEL actuator motor and changes the movement of the output cam by

VVEL SYSTEM

[VQ37VHR]

< SYSTEM DESCRIPTION >

shifting the link supporting point. As a result, valve lift changes continuously to improve engine output and response.

Component Parts Location

INFOID:000000005151677

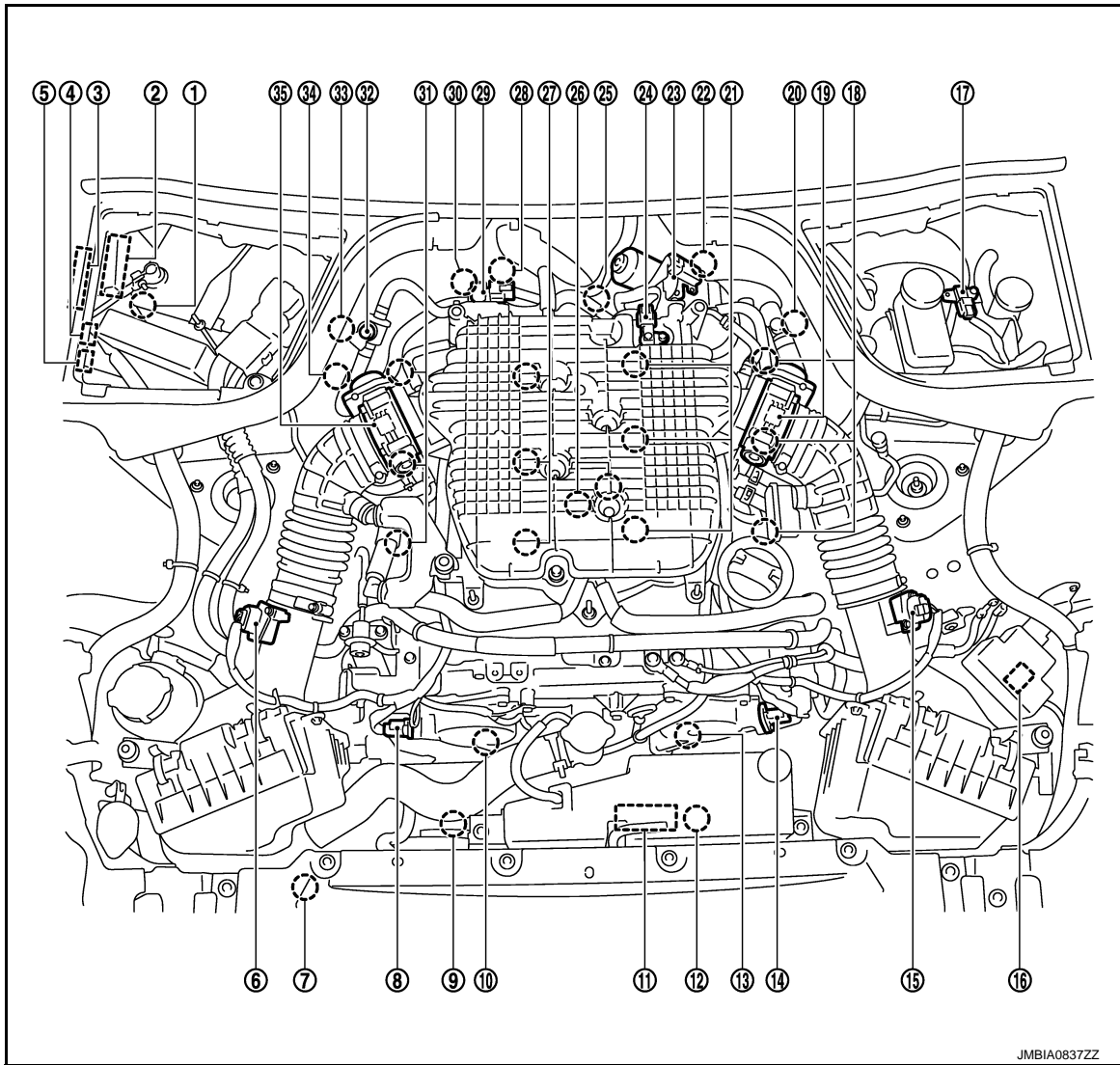

- | | | |
|---|---|---|
| 1. Battery current sensor | 2. IPDM E/R | 3. VVEL control module |
| 4. Cooling fan relay | 5. VVEL actuator motor relay | 6. Mass air flow sensor (with intake air temperature sensor) (bank 1) |
| 7. Refrigerant pressure sensor | 8. Camshaft position sensor (PHASE) (bank 1) | 9. Cooling fan motor-2 |
| 10. Intake valve timing control solenoid valve (bank 1) | 11. Cooling fan control module | 12. Cooling fan motor-1 |
| 13. Intake valve timing control solenoid valve (bank 2) | 14. Camshaft position sensor (PHASE) (bank 2) | 15. Mass air flow sensor (bank 2) |
| 16. ICC brake hold relay (ICC models) | 17. Brake booster pressure sensor | 18. Ignition coil (with power transistor) and spark plug (bank 2) |
| 19. Electric throttle control actuator (bank 2) | 20. A/F sensor 1 (bank 2) | 21. Fuel injector (bank 2) |
| 22. VVEL control shaft position sensor (bank 2) | 23. VVEL actuator motor (bank 2) | 24. Manifold absolute pressure (MAP) sensor |
| 25. Engine coolant temperature sensor | 26. Knock sensor | 27. Fuel injector (bank 1) |
| 28. VVEL actuator motor (bank 1) | 29. EVAP canister purge volume control solenoid valve | 30. VVEL control shaft position sensor (bank 1) |

VVEL SYSTEM

[VQ37VHR]

< SYSTEM DESCRIPTION >

- | | | |
|--|---|---------------------------|
| 31. Ignition coil (with power transistor and spark plug (bank 1) | 32. EVAP service port | 33. A/F sensor 1 (bank 1) |
| 34. Crankshaft position sensor (POS) | 35. Electric throttle control actuator (bank 1) | |

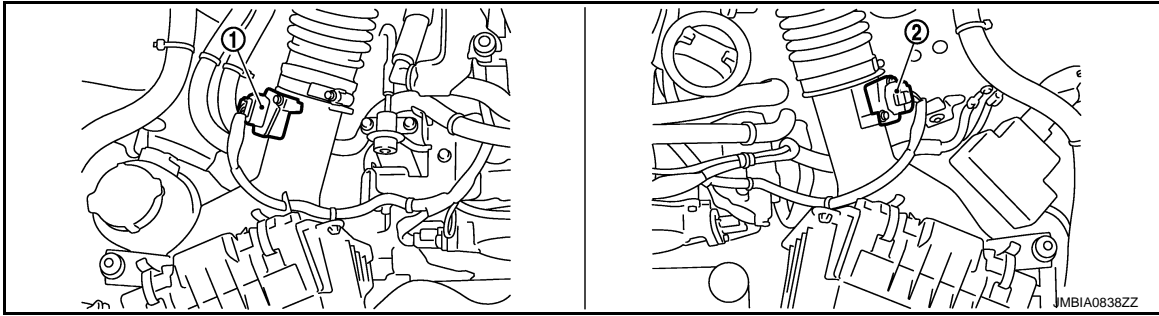

- | | |
|---|----------------------------------|
| 1. Mass air flow sensor (with intake air temperature sensor) (bank 1) | 2. Mass air flow sensor (bank 2) |
|---|----------------------------------|

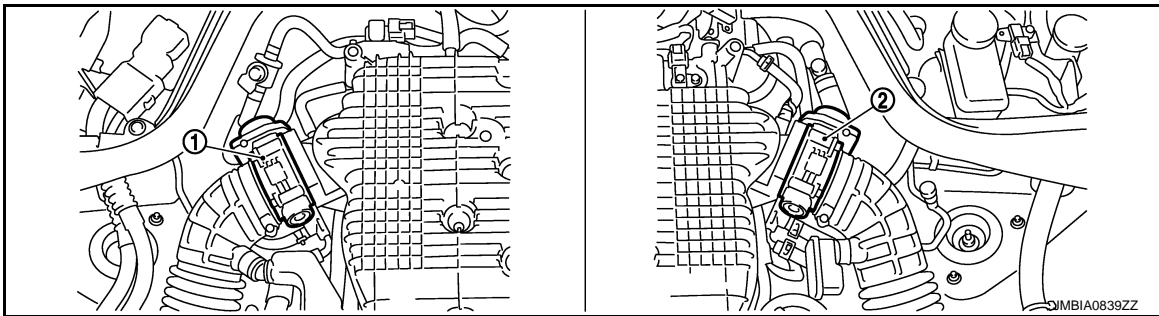

- | | |
|--|--|
| 1. Electric throttle control actuator (bank 1) | 2. Electric throttle control actuator (bank 2) |
|--|--|

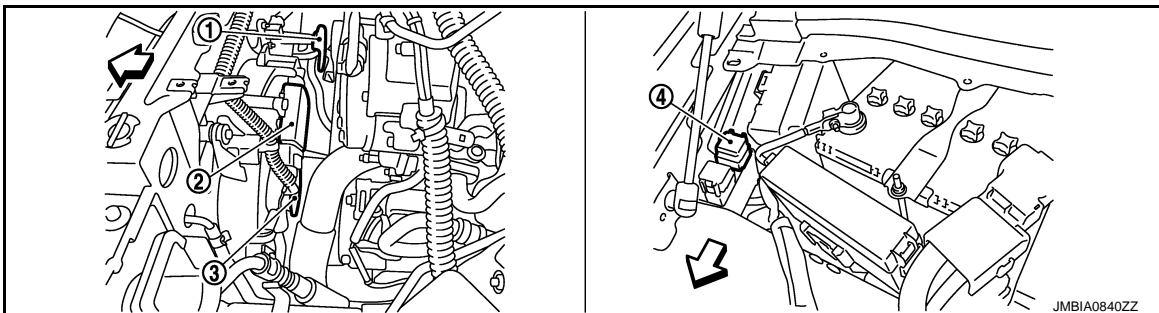

↔ : Vehicle front

- | | | |
|------------------------|-------------------------------|------------------------|
| 1. Cooling fan motor-2 | 2. Cooling fan control module | 3. Cooling fan motor-1 |
| 4. Cooling fan relay | | |

A

EC

C

D

E

F

G

H

I

J

K

L

M

N

O

P

VVEL SYSTEM

< SYSTEM DESCRIPTION >

[VQ37VHR]

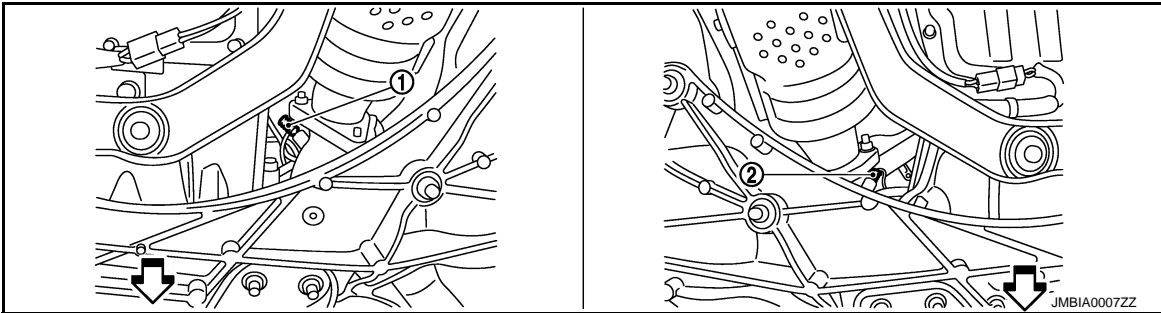
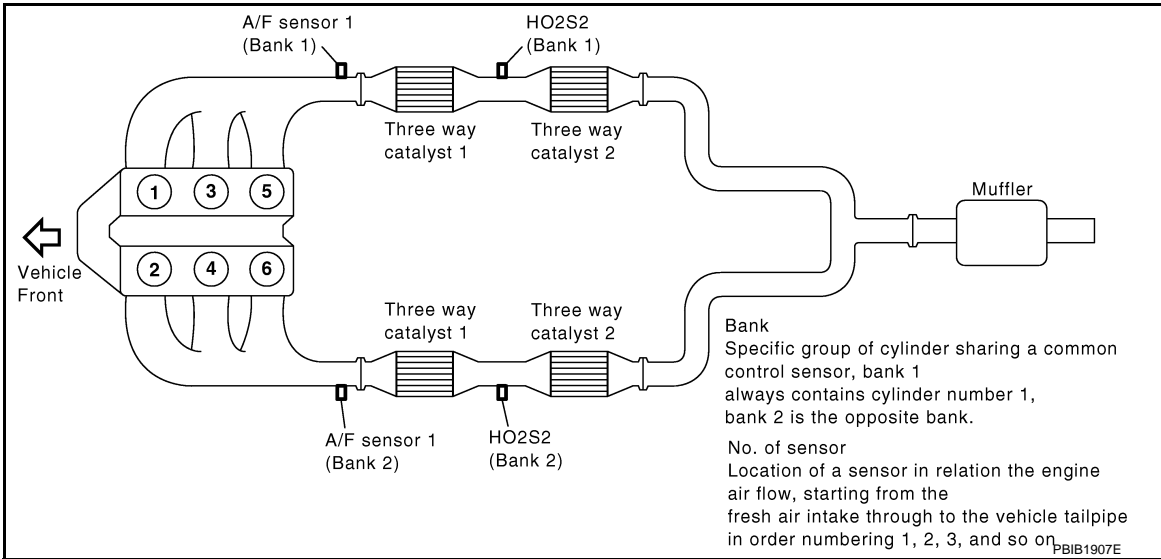

← : Vehicle front

1. A/F sensor 1 (bank 1)
2. A/F sensor 1 (bank 2)

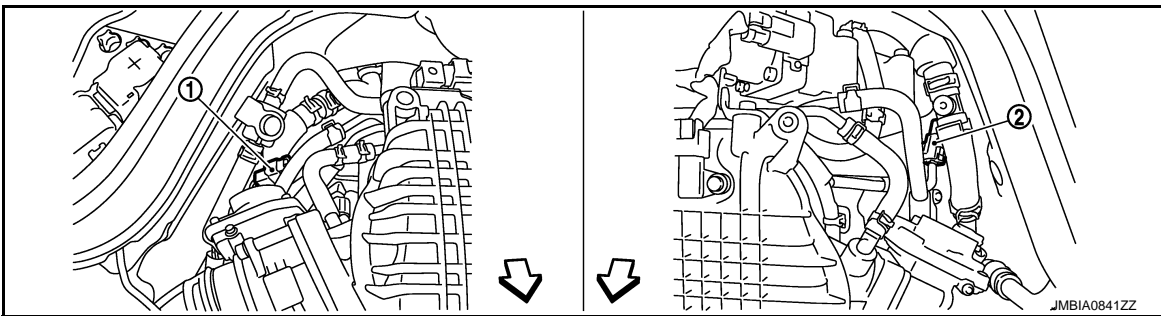

← : Vehicle front

1. A/F sensor 1 (bank 1) harness connector
2. A/F sensor 1 (bank 2) harness connector

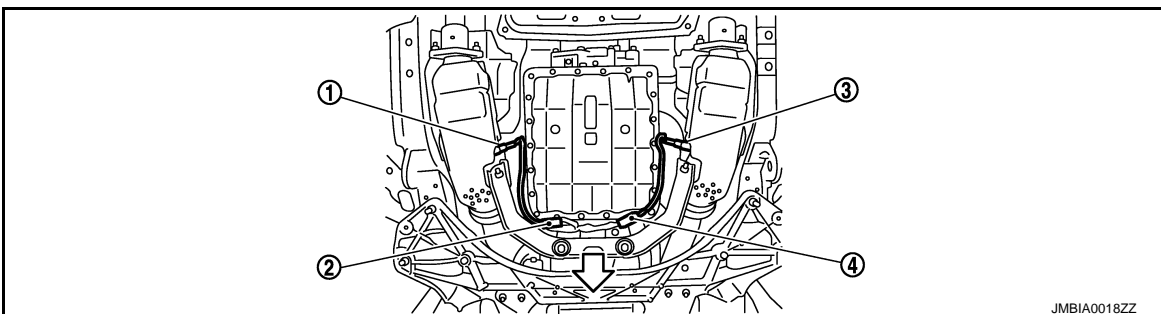

↩: Vehicle front

1. Heated oxygen sensor 2 (bank 2)
2. Heated oxygen sensor 2 (bank 2) harness connector
3. Heated oxygen sensor 2 (bank 1)
4. Heated oxygen sensor 2 (bank 1) harness connector

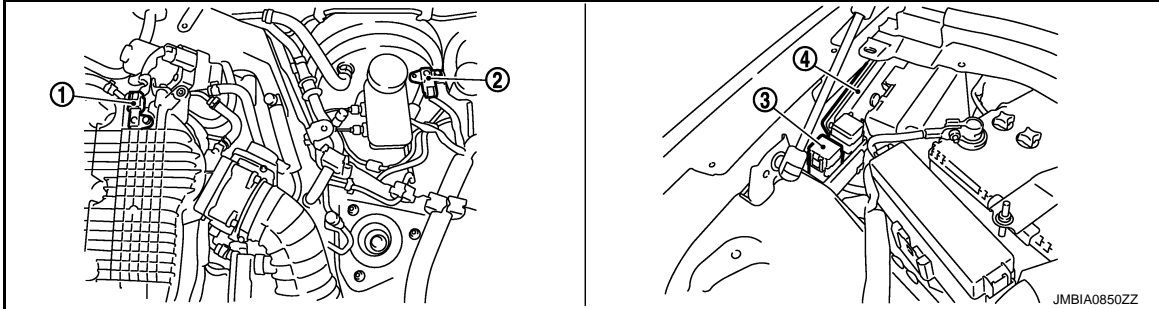

1. Manifold absolute pressure (MAP) sensor
2. Brake booster pressure sensor
3. VVEL actuator motor relay
4. VVEL control module



↩: Vehicle front

1. VVEL control shaft position sensor (bank 1)
2. VVEL actuator motor (bank 1)
3. VVEL actuator motor (bank 2)
4. VVEL control shaft position sensor (bank 2)

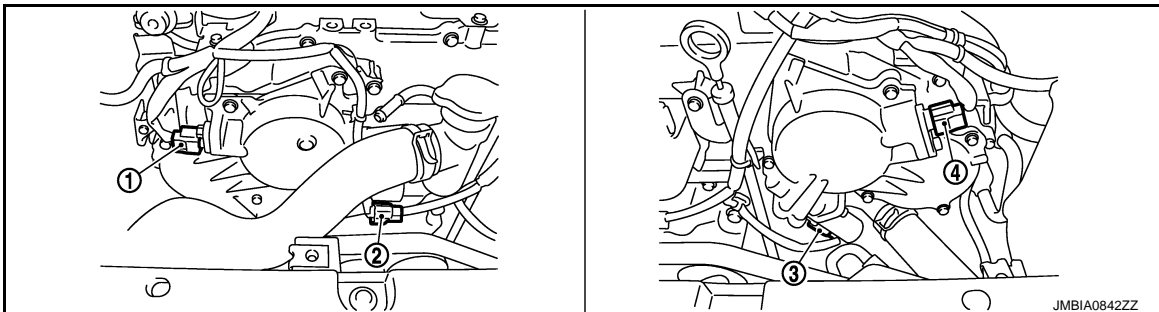

1. Camshaft position sensor (PHASE) (bank 1)
2. Intake valve timing control solenoid valve (bank 1) harness connector
3. Intake valve timing control solenoid valve (bank 2) harness connector
4. Camshaft position sensor (PHASE) (bank 2)

A
EC
C
D
E
F
G
H
I
J
K
L
M
N
O
P

VVEL SYSTEM

< SYSTEM DESCRIPTION >

[VQ37VHR]

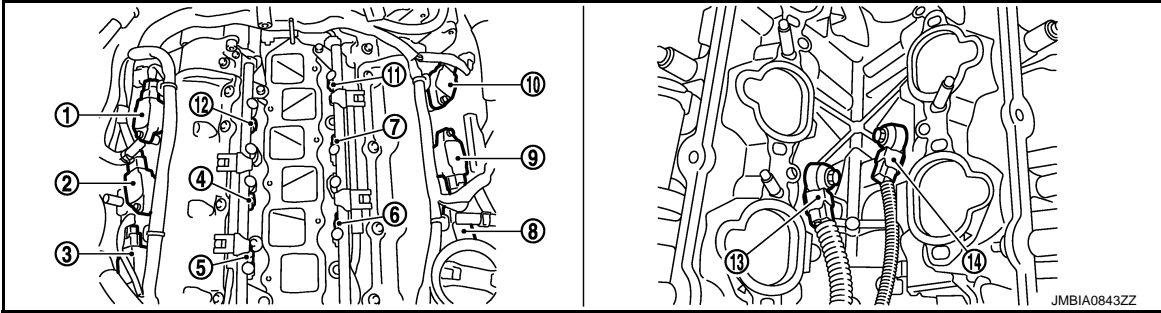

- | | | |
|--|---|---|
| 1. Ignition coil No.5 (with power transistor) | 2. Ignition coil No.3 (with power transistor) | 3. Ignition coil No.1 (with power transistor) |
| 4. Fuel injector No.3 | 5. Fuel injector No.1 | 6. Fuel injector No.2 |
| 7. Fuel injector No.4 | 8. Ignition coil No.2 (with power transistor) | 9. Ignition coil No.4 (with power transistor) |
| 10. Ignition coil No.6 (with power transistor) | 11. Fuel injector No.6 | 12. Fuel injector No.5 |
| 13. Knock sensor (bank 1) | 14. Knock sensor (bank 2) | |

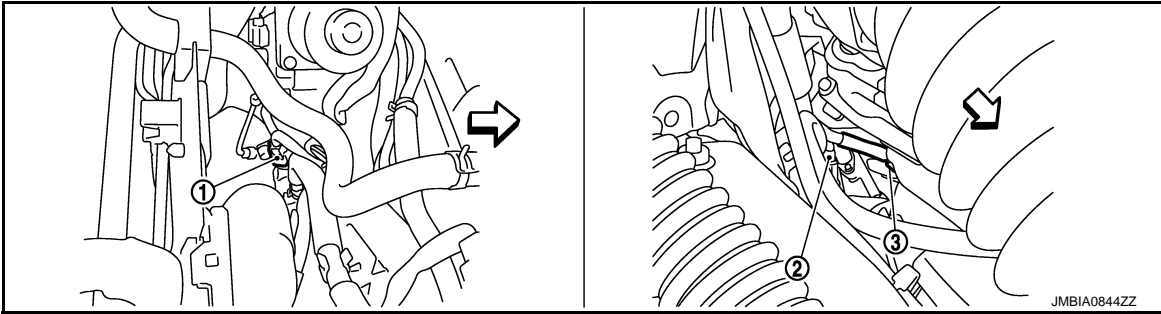

↶ : Vehicle front

- | | | |
|--------------------------------------|--------------------------|-------------------------------------|
| 1. Engine coolant temperature sensor | 2. A/F sensor 1 (bank 1) | 3. Crankshaft position sensor (POS) |
|--------------------------------------|--------------------------|-------------------------------------|

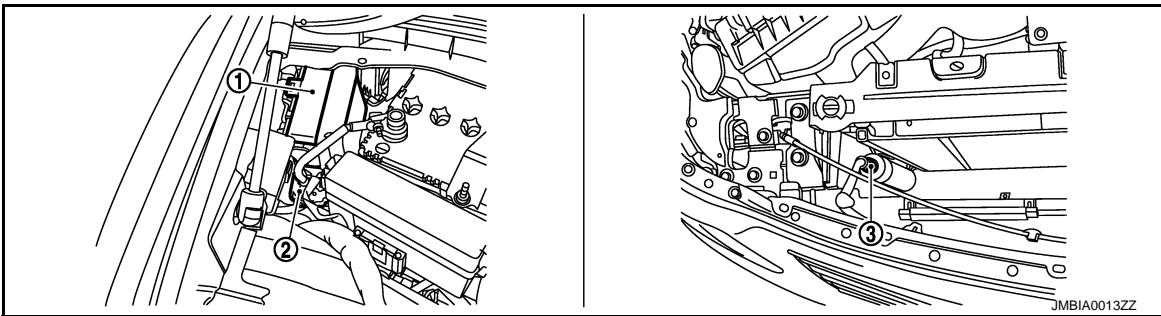

- | | | |
|-------------|---------------------------|--------------------------------|
| 1. IPDM E/R | 2. Battery current sensor | 3. Refrigerant pressure sensor |
|-------------|---------------------------|--------------------------------|

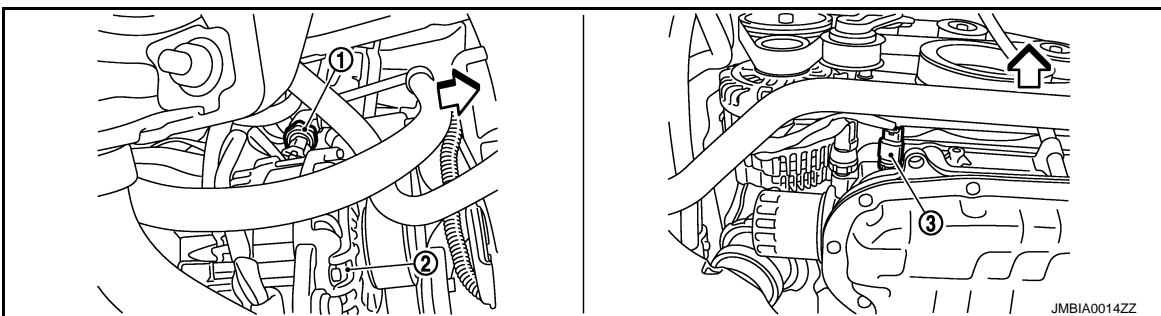

VVEL SYSTEM

< SYSTEM DESCRIPTION >

[VQ37VHR]

↔: Vehicle front

1. Power steering pressure sensor 2. Alternator 3. Engine oil temperature sensor

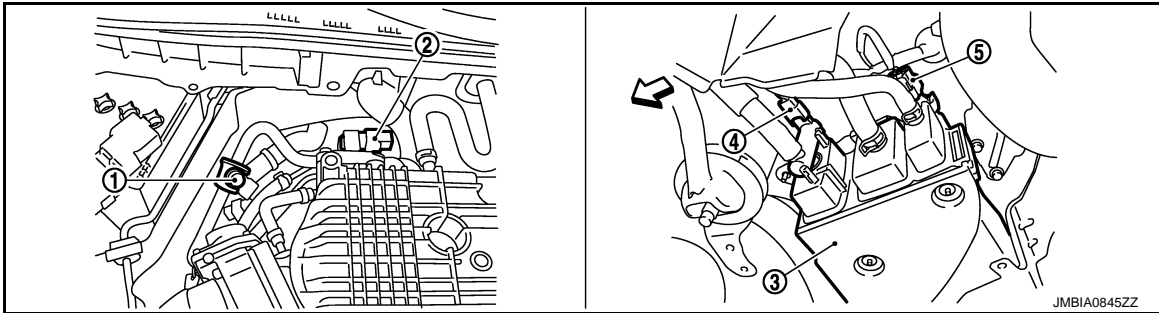

↔: Vehicle front

1. EVAP service port 2. EVAP canister purge volume control 3. EVAP canister solenoid valve
4. EVAP canister vent control valve 5. EVAP control system pressure sensor

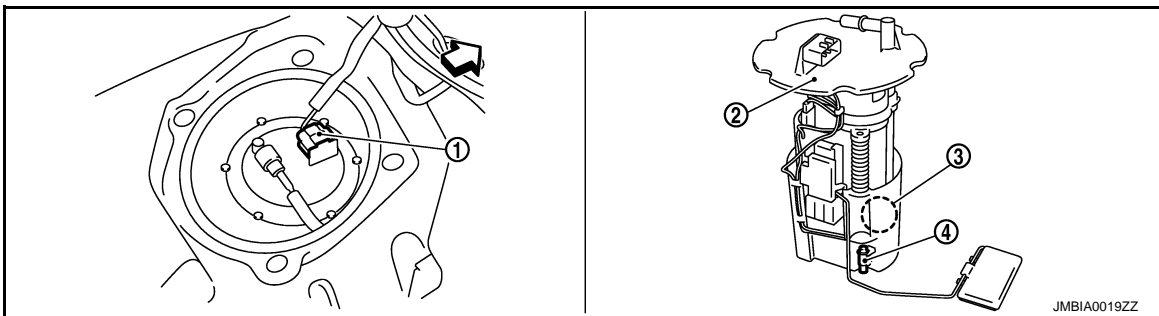

↔: Vehicle front

1. Fuel level sensor unit and fuel pump harness connector 2. Fuel level sensor unit and fuel pump 3. Fuel pressure regulator
4. Fuel tank temperature sensor

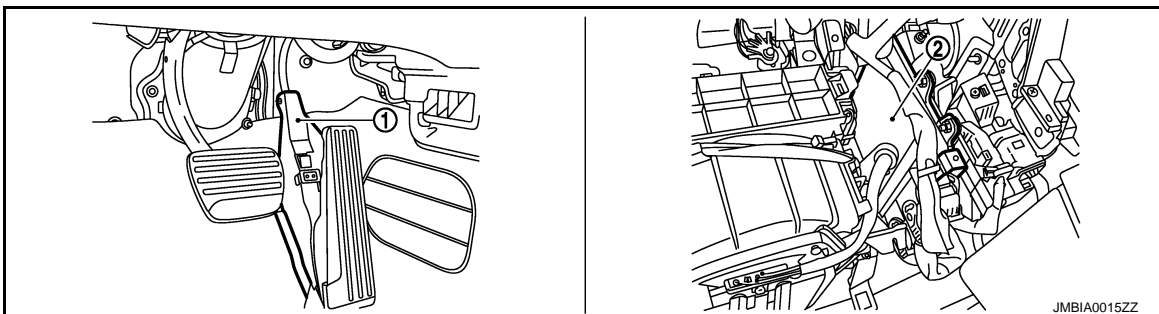

1. Accelerator pedal position sensor 2. ECM

A
EC
C
D
E
F
G
H
I
J
K
L
M
N
O
P

VVEL SYSTEM

< SYSTEM DESCRIPTION >

[VQ37VHR]

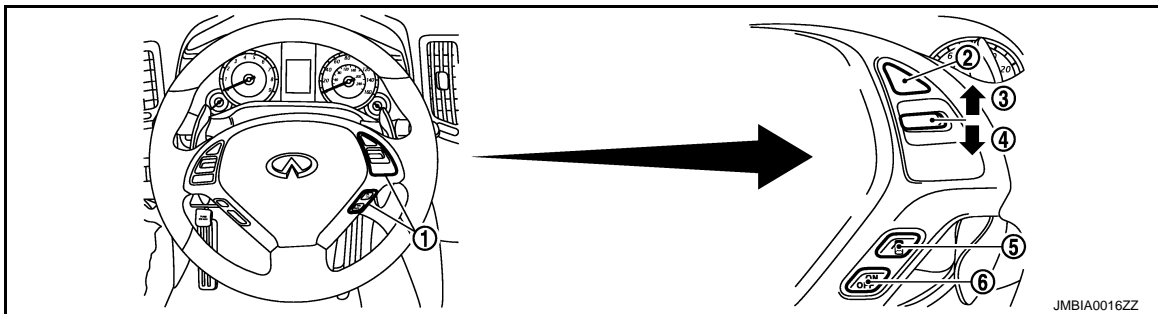

- 1. ICC steering switch
- 2. CANCEL switch
- 3. RESUME/ACCELERATE switch
- 4. SET/COAST switch
- 5. DISTANCE switch
- 6. MAIN switch

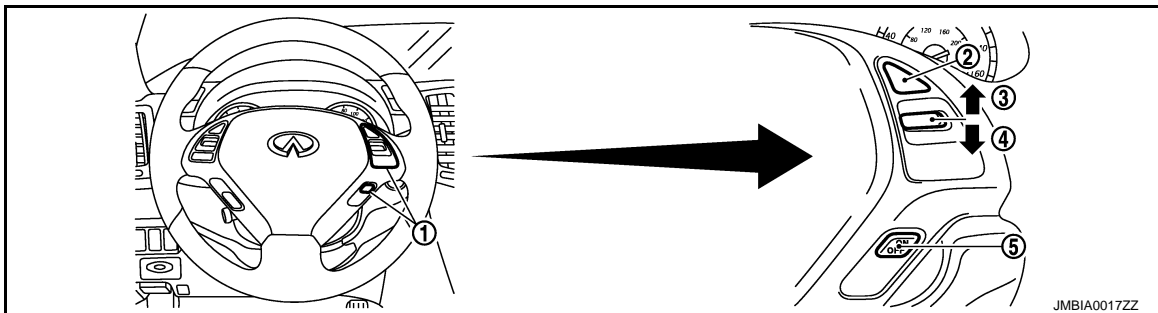

- 1. ASCD steering switch
- 2. CANCEL switch
- 3. RESUME/ACCELERATE switch
- 4. SET/COAST switch
- 5. MAIN switch

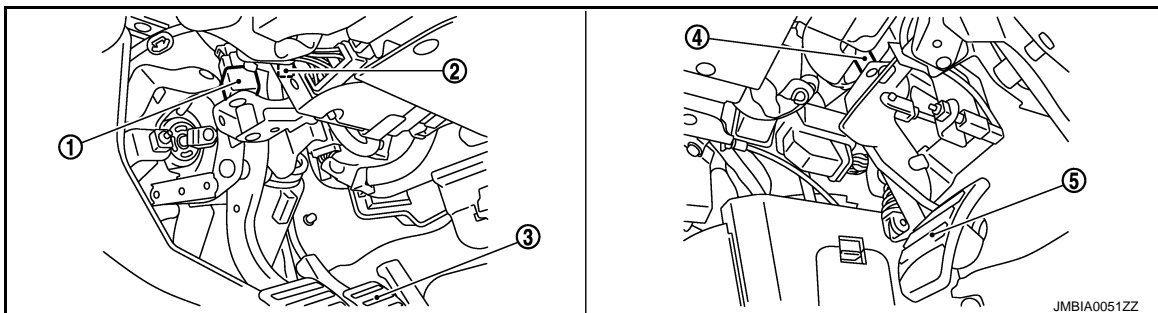

- 1. Stop lamp switch
- 2. ASCD brake switch (ASCD models)
ICC brake switch (ICC models)
- 3. Brake pedal
- 4. ASCD clutch switch (ASCD models)
ICC clutch switch (ICC models)
- 5. Clutch pedal

Component Description

INFOID:000000005151678

Component	Reference
Accelerator pedal position sensor	EC-463. "Description"
Camshaft position sensro (PHASE)	EC-273. "Description"
Crankshaft position sensor (POS)	EC-269. "Description"
VVEL actuator motor	EC-380. "Description"
VVEL actuator motor relay	EC-384. "Description"
VVEL control module	EC-453. "Description"
VVEL control shaft position sensor	EC-376. "Description"

ON BOARD DIAGNOSTIC (OBD) SYSTEM

[VQ37VHR]

< SYSTEM DESCRIPTION >

ON BOARD DIAGNOSTIC (OBD) SYSTEM

Diagnosis Description

INFOID:000000005151679

INTRODUCTION

The ECM has an on board diagnostic system, which detects malfunctions related to engine sensors or actuators. The ECM also records various emission-related diagnostic information including:

Emission-related diagnostic information	Diagnostic service
Diagnostic Trouble Code (DTC)	Service \$03 of SAE J1979
Freeze Frame data	Service \$02 of SAE J1979
System Readiness Test (SRT) code	Service \$01 of SAE J1979
1st Trip Diagnostic Trouble Code (1st Trip DTC)	Service \$07 of SAE J1979
1st Trip Freeze Frame data	—
Test values and Test limits	Service \$06 of SAE J1979
Calibration ID	Service \$09 of SAE J1979

The above information can be checked using procedures listed in the table below.

x: Applicable —: Not applicable

	DTC	1st trip DTC	Freeze Frame data	1st trip Freeze Frame data	SRT code	SRT status	Test value
CONSULT-III	x	x	x	x	x	x	—
GST	x	x	x	—	x	x	x
ECM	x	x*	—	—	—	x	—

*: When DTC and 1st trip DTC simultaneously appear on the display, they cannot be clearly distinguished from each other.

The malfunction indicator lamp (MIL) on the instrument panel illuminates when the same malfunction is detected in two consecutive trips (Two trip detection logic), or when the ECM enters fail-safe mode. (Refer to [EC-553, "Fail safe"](#).)

TWO TRIP DETECTION LOGIC

When a malfunction is detected for the first time, 1st trip DTC and 1st trip Freeze Frame data are stored in the ECM memory. The MIL will not illuminate at this stage. <1st trip>

If the same malfunction is detected again during the next drive, the DTC and Freeze Frame data are stored in the ECM memory, and the MIL illuminates. The MIL illuminates at the same time the DTC is stored. <2nd trip> The "trip" in the "Two Trip Detection Logic" means a driving mode in which self-diagnosis is performed during vehicle operation. Specific on board diagnostic items will cause the ECM to illuminate or blink the MIL, and store DTC and Freeze Frame data, even in the 1st trip, as shown below.

x: Applicable —: Not applicable

Items	MIL				DTC		1st trip DTC	
	1st trip		2nd trip		1st trip displaying	2nd trip displaying	1st trip displaying	2nd trip displaying
	Blinking	Illuminated	Blinking	Illuminated				
Misfire (Possible three way catalyst damage) — DTC: P0300 - P0306 is being detected	x	—	—	—	—	—	x	—
Misfire (Possible three way catalyst damage) — DTC: P0300 - P0306 is being detected	—	—	x	—	—	x	—	—
One trip detection diagnoses (Refer to EC-557, "DTC Index" .)	—	x	—	—	x	—	—	—
Except above	—	—	—	x	—	x	x	—

DTC AND FREEZE FRAME DATA

DTC and 1st Trip DTC

ON BOARD DIAGNOSTIC (OBD) SYSTEM

[VQ37VHR]

< SYSTEM DESCRIPTION >

The 1st trip DTC (whose number is the same as the DTC number) is displayed for the latest self-diagnostic result obtained. If the ECM memory was cleared previously, and the 1st trip DTC did not recur, the 1st trip DTC will not be displayed.

If a malfunction is detected during the 1st trip, the 1st trip DTC is saved in the ECM memory. The MIL will not illuminate (two trip detection logic). If the same malfunction is not detected in the 2nd trip (meeting the required driving pattern), the 1st trip DTC is cleared from the ECM memory. If the same malfunction is detected in the 2nd trip, both the 1st trip DTC and DTC are stored in the ECM memory and the MIL illuminates. In other words, the DTC is saved in the ECM memory and the MIL illuminates when the same malfunction occurs in two consecutive trips. If a 1st trip DTC is saved and a non-diagnostic operation is performed between the 1st and 2nd trips, only the 1st trip DTC will continue to be stored. For malfunctions that blink or illuminate the MIL during the 1st trip, the DTC and 1st trip DTC are stored in the ECM memory.

Procedures for clearing the DTC and the 1st trip DTC from the ECM memory are described in "HOW TO ERASE EMISSION-RELATED DIAGNOSTIC INFORMATION".

For malfunctions in which 1st trip DTCs are displayed, refer to "EMISSION-RELATED DIAGNOSTIC INFORMATION ITEMS". These items are required by legal regulations to continuously monitor the system/component. In addition, the items monitored non-continuously are also displayed on CONSULT-III.

1st trip DTC is specified in Service \$07 of SAE J1979. 1st trip DTC detection occurs without illuminating the MIL and therefore does not warn the driver of a malfunction. However, 1st trip DTC detection will not prevent the vehicle from being tested, for example during Inspection/Maintenance (I/M) tests.

When a 1st trip DTC is detected, check, print out or write down and erase (1st trip) DTC and Freeze Frame data as specified in Work Flow procedure Step 2, refer to [EC-9, "Work Flow"](#). Then perform DTC Confirmation Procedure or Component Function Check to try to duplicate the malfunction. If the malfunction is duplicated, the item requires repair.

Freeze Frame Data and 1st Trip Freeze Frame Data

The ECM records the driving conditions such as fuel system status, calculated load value, engine coolant temperature, short-term fuel trim, long-term fuel trim, engine speed, vehicle speed, absolute throttle position, base fuel schedule and intake air temperature at the moment a malfunction is detected.

Data which are stored in the ECM memory, along with the 1st trip DTC, are called 1st trip freeze frame data. The data, stored together with the DTC data, are called freeze frame data and displayed on CONSULT-III or GST. The 1st trip freeze frame data can only be displayed on the CONSULT-III screen, not on the GST.

Only one set of freeze frame data (either 1st trip freeze frame data or freeze frame data) can be stored in the ECM. 1st trip freeze frame data is stored in the ECM memory along with the 1st trip DTC. There is no priority for 1st trip freeze frame data and it is updated each time a different 1st trip DTC is detected. However, once freeze frame data (2nd trip detection/MIL on) is saved in the ECM memory, 1st trip freeze frame data is no longer stored. Remember, only one set of freeze frame data can be stored in the ECM. The ECM has the following priorities to update the data.

Priority	Items	
1	Freeze frame data	Misfire — DTC: P0300 - P0306 Fuel Injection System Function — DTC: P0171, P0172, P0174, P0175
2		Except the above items (Includes A/T related items)
3	1st trip freeze frame data	

For example, the EGR malfunction (Priority: 2) was detected and the freeze frame data was saved in the 2nd trip. After that when the misfire (Priority: 1) is detected in another trip, the freeze frame data will be updated from the EGR malfunction to the misfire. The 1st trip freeze frame data is updated each time a different malfunction is detected. There is no priority for 1st trip freeze frame data. However, once freeze frame data is stored in the ECM memory, 1st trip freeze data is no longer stored (because only one freeze frame data or 1st trip freeze frame data can be stored in the ECM). If freeze frame data is stored in the ECM memory and freeze frame data with the same priority occurs later, the first (original) freeze frame data remains unchanged in the ECM memory.

Both 1st trip freeze frame data and freeze frame data (along with the DTCs) are cleared when the ECM memory is erased. Procedures for clearing the ECM memory are described in "HOW TO ERASE EMISSION-RELATED DIAGNOSTIC INFORMATION".

How to Read DTC and 1st Trip DTC

 **With CONSULT-III**

 **With GST**

CONSULT-III or GST (Generic Scan Tool) Examples: P0340, P0850, P1148, etc.
These DTCs are prescribed by SAE J2012.

ON BOARD DIAGNOSTIC (OBD) SYSTEM

[VQ37VHR]

< SYSTEM DESCRIPTION >

(CONSULT-III also displays the malfunctioning component or system.)

No Tools

The number of blinks of the MIL in the Diagnostic Test Mode II (Self-Diagnostic Results) indicates the DTC. Example: 0340, 0850, 1148, etc.

These DTCs are controlled by NISSAN.

- **1st trip DTC No. is the same as DTC No.**
- **Output of a DTC indicates a malfunction. However, GST and the Diagnostic Test Mode II do not indicate whether the malfunction is still occurring or has occurred in the past and has returned to normal. CONSULT-III can identify malfunction status as shown below. Therefore, using CONSULT-III (if available) is recommended.**

DTC or 1st trip DTC of a malfunction is displayed in SELF-DIAGNOSTIC RESULTS mode of CONSULT-III. Time data indicates how many times the vehicle was driven after the last detection of a DTC.

If the DTC is being detected currently, the time data will be [0].

If a 1st trip DTC is stored in the ECM, the time data will be [1t].

How to Erase DTC and 1st Trip DTC

With CONSULT-III

NOTE:

- If the ignition switch stays ON after repair work, be sure to turn ignition switch OFF once. Wait at least 10 seconds and then turn it ON (engine stopped) again.
- If the DTC is not for A/T related items (see [EC-557](#)), skip step 1.
 1. Erase DTC in TCM. Refer to [TM-150, "Diagnosis Description"](#).
 2. Select "ENGINE" with CONSULT-III.
 3. Select "SELF-DIAG RESULTS".
 4. Touch "ERASE". (DTC in ECM will be erased.)

With GST

NOTE:

- If the ignition switch stays ON after repair work, be sure to turn ignition switch OFF once. Wait at least 10 seconds and then turn it ON (engine stopped) again.
 1. Select Service \$04 with GST (Generic Scan Tool).

No Tools

NOTE:

- If the ignition switch stays ON after repair work, be sure to turn ignition switch OFF once. Wait at least 10 seconds and then turn it ON (engine stopped) again.
 1. Erase DTC in ECM. Refer to How to Erase Diagnostic Test Mode II (Self-diagnostic Results).
- **If the battery is disconnected, the emission-related diagnostic information will be cleared within 24 hours.**
- **The following data are cleared when the ECM memory is erased.**
 - Diagnostic trouble codes
 - 1st trip diagnostic trouble codes
 - Freeze frame data
 - 1st trip freeze frame data
 - System readiness test (SRT) codes
 - Test values

Actual work procedures are explained using a DTC as an example. Be careful so that not only the DTC, but all of the data listed above, are cleared from the ECM memory during work procedures.

SYSTEM READINESS TEST (SRT) CODE

System Readiness Test (SRT) code is specified in Service \$01 of SAE J1979.

As part of an enhanced emissions test for Inspection & Maintenance (I/M), certain states require the status of SRT be used to indicate whether the ECM has completed self-diagnosis of major emission systems and components. Completion must be verified in order for the emissions inspection to proceed.

If a vehicle is rejected for a State emissions inspection due to one or more SRT items indicating "INCMP", use the information in this Service Manual to set the SRT to "CMPLT".

In most cases the ECM will automatically complete its self-diagnosis cycle during normal usage, and the SRT status will indicate "CMPLT" for each application system. Once set as "CMPLT", the SRT status remains "CMPLT" until the self-diagnosis memory is erased.

Occasionally, certain portions of the self-diagnostic test may not be completed as a result of the customer's normal driving pattern; the SRT will indicate "INCMP" for these items.

NOTE:

ON BOARD DIAGNOSTIC (OBD) SYSTEM

[VQ37VHR]

< SYSTEM DESCRIPTION >

The SRT will also indicate "INCMP" if the self-diagnosis memory is erased for any reason or if the ECM memory power supply is interrupted for several hours.

If, during the state emissions inspection, the SRT indicates "CMPLT" for all test items, the inspector will continue with the emissions test. However, if the SRT indicates "INCMP" for one or more of the SRT items the vehicle is returned to the customer untested.

NOTE:

If MIL illuminates during the state emissions inspection, the vehicle is also returned to the customer untested even though the SRT indicates "CMPLT" for all test items. Therefore, it is important to check SRT ("CMPLT") and DTC (No DTCs) before the inspection.

SRT Item

The table below shows required self-diagnostic items to set the SRT to "CMPLT".

SRT item (CONSULT-III indication)	Performance Priority*	Required self-diagnostic items to set the SRT to "CMPLT"	Corresponding DTC No.
CATALYST	2	Three way catalyst function	P0420, P0430
EVAP SYSTEM	2	EVAP control system purge flow monitoring	P0441
	1	EVAP control system	P0442
	2	EVAP control system	P0456
HO2S	2	Air fuel ratio (A/F) sensor 1	P0133, P0153
		Heated oxygen sensor 2	P0137, P0157
		Heated oxygen sensor 2	P0138, P0158
		Heated oxygen sensor 2	P0139, P0159

*: If completion of several SRTs is required, perform driving patterns (DTC confirmation procedure), one by one based on the priority for models with CONSULT-III.

SRT Set Timing

SRT is set as "CMPLT" after self-diagnosis has been performed one or more times. Completion of SRT is done regardless of whether the result is OK or NG. The set timing is different between OK and NG results and is shown in the table below.

Self-diagnosis result		Example				
		Diagnosis	Ignition cycle			
			← ON →	OFF	← ON →	OFF
All OK	Case 1	P0400	OK (1)	— (1)	OK (2)	— (2)
		P0402	OK (1)	— (1)	— (1)	OK (2)
		P1402	OK (1)	OK (2)	— (2)	— (2)
		SRT of EGR	"CMPLT"	"CMPLT"	"CMPLT"	"CMPLT"
	Case 2	P0400	OK (1)	— (1)	— (1)	— (1)
		P0402	— (0)	— (0)	OK (1)	— (1)
		P1402	OK (1)	OK (2)	— (2)	— (2)
		SRT of EGR	"INCMP"	"INCMP"	"CMPLT"	"CMPLT"
NG exists	Case 3	P0400	OK	OK	—	—
		P0402	—	—	—	—
		P1402	NG	—	NG	NG (Consecutive NG)
		(1st trip) DTC	1st trip DTC	—	1st trip DTC	DTC (= MIL ON)
		SRT of EGR	"INCMP"	"INCMP"	"INCMP"	"CMPLT"

OK: Self-diagnosis is carried out and the result is OK.

NG: Self-diagnosis is carried out and the result is NG.

—: Self-diagnosis is not carried out.

ON BOARD DIAGNOSTIC (OBD) SYSTEM

[VQ37VHR]

< SYSTEM DESCRIPTION >

When all SRT related self-diagnoses show OK results in a single cycle (Ignition OFF-ON-OFF), the SRT will indicate "CMPLT". → Case 1 above

When all SRT related self-diagnoses show OK results through several different cycles, the SRT will indicate "CMPLT" at the time the respective self-diagnoses have at least one OK result. → Case 2 above

If one or more SRT related self-diagnoses show NG results in 2 consecutive cycles, the SRT will also indicate "CMPLT". → Case 3 above

The table above shows that the minimum number of cycles for setting SRT as "INCMP" is the number one (1) for each self-diagnosis (Case 1 & 2) or the number two (2) for one of self-diagnoses (Case 3). However, in preparation for the state emissions inspection, it is unnecessary for each self-diagnosis to be executed twice (Case 3) for the following reasons:

- The SRT will indicate "CMPLT" at the time the respective self-diagnoses have one (1) OK result.
- The emissions inspection requires "CMPLT" of the SRT only with OK self-diagnosis results.
- When, During SRT driving pattern, the 1st trip DTC (NG) is detected prior to "CMPLT" of SRT and the self-diagnosis memory must be erased from the ECM after repair.
- If the 1st trip DTC is erased, all the SRT will indicate "INCMP".

NOTE:

SRT can be set as "CMPLT" together with the DTC(s). Therefore, DTC check must always be carried out prior to the state emission inspection even though the SRT indicates "CMPLT".

SRT Service Procedure

If a vehicle has failed the state emissions inspection due to one or more SRT items indicating "INCMP", review the flowchart diagnostic sequence below.

A
EC
C
D
E
F
G
H
I
J
K
L
M
N
O
P

ON BOARD DIAGNOSTIC (OBD) SYSTEM

< SYSTEM DESCRIPTION >

[VQ37VHR]

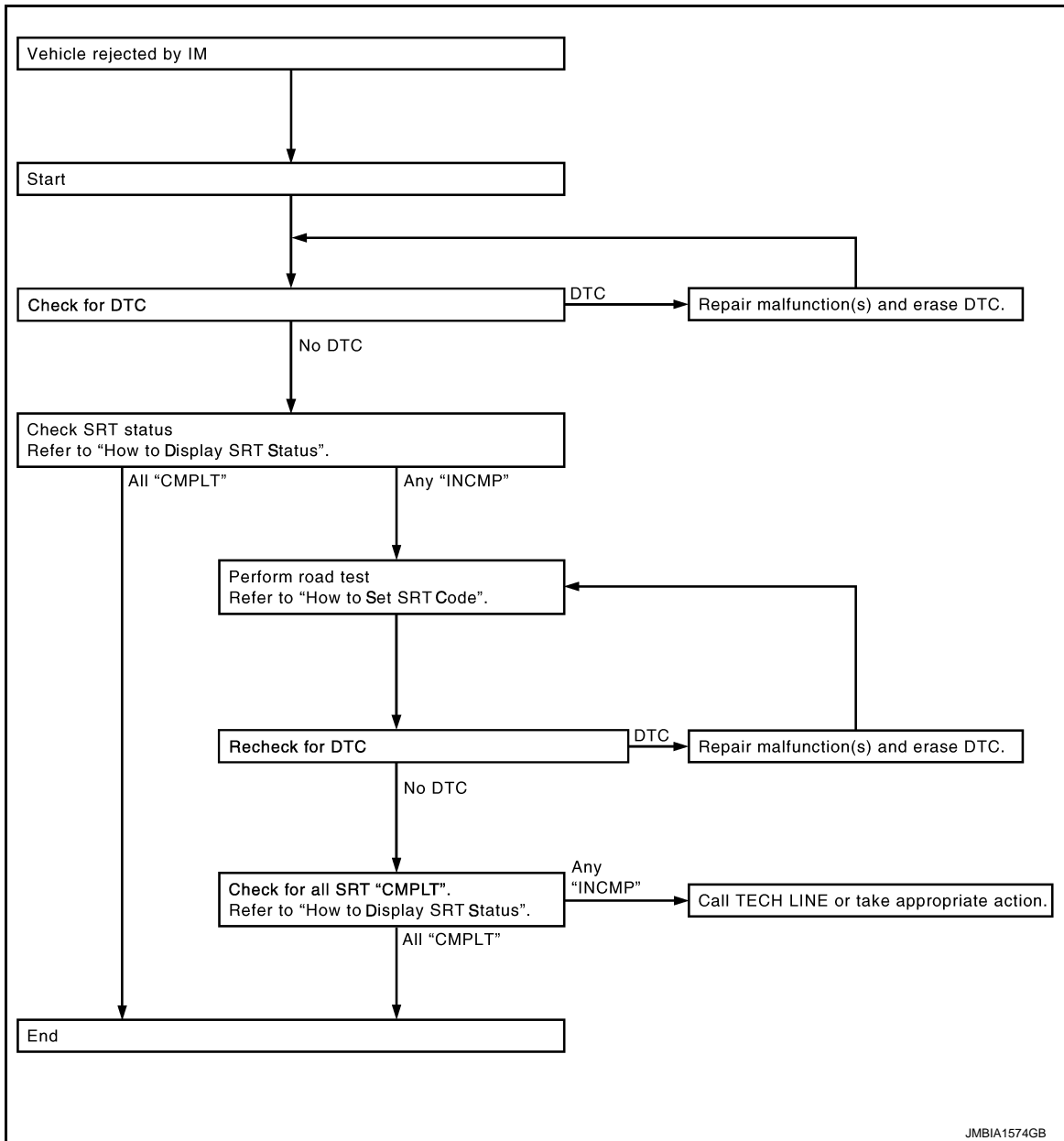

How to Display SRT Status

WITH CONSULT-III

Selecting "SRT STATUS" in "DTC CONFIRMATION" mode with CONSULT-III.

For items whose SRT codes are set, "CMPLT" is displayed on the CONSULT-III screen; for items whose SRT codes are not set, "INCMP" is displayed.

NOTE:

Though displayed on the CONSULT-III screen, "HO2S HTR" is not SRT item.

WITH GST

Selecting Service \$01 with GST (Generic Scan Tool)

NO TOOLS

A SRT code itself cannot be displayed, however SRT status can.

1. Turn ignition switch ON and wait 20 seconds.
2. SRT status is indicated as shown below.
 - When all SRT codes are set, MIL illuminates continuously.

ON BOARD DIAGNOSTIC (OBD) SYSTEM

[VQ37VHR]

< SYSTEM DESCRIPTION >

- When any SRT codes are not set, MIL will blink periodically for 10 seconds.

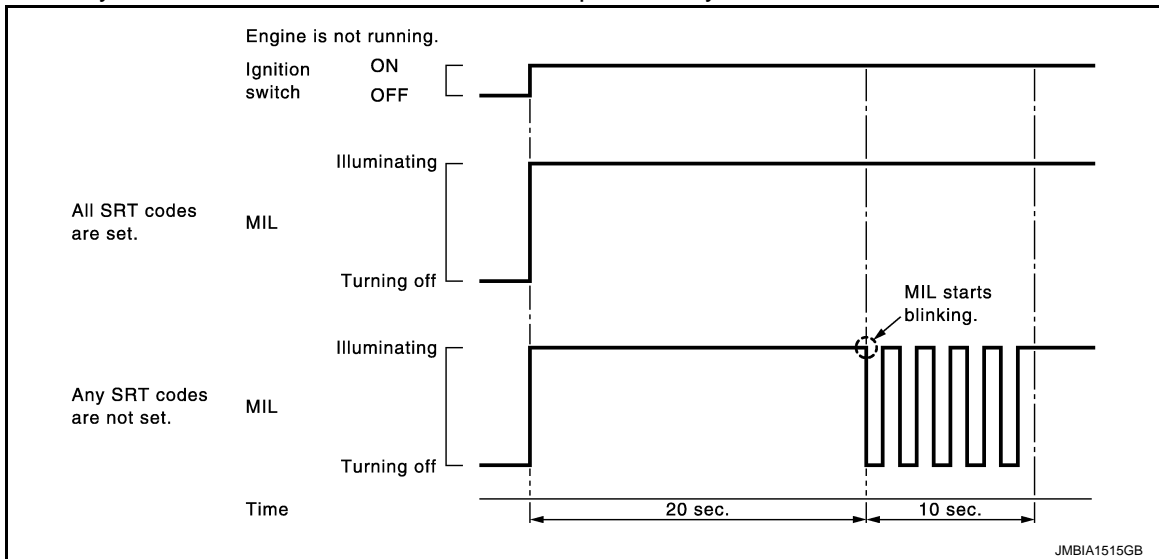

MALFUNCTION INDICATOR LAMP (MIL)

Description

The MIL is located on the combination meter.

- The MIL will illuminate when the ignition switch is turned ON without the engine running. This is a bulb check. If the MIL does not illuminate, check MIL circuit. Refer to [EC-508, "Component Function Check"](#).
- When the engine is started, the MIL should go off. If the MIL remains illuminating, the on board diagnostic system has detected an engine system malfunction.

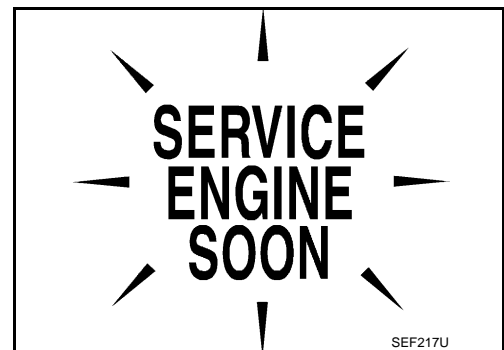





On Board Diagnostic System Function

The on board diagnostic system has the following three functions.

ON BOARD DIAGNOSTIC (OBD) SYSTEM

< SYSTEM DESCRIPTION >

[VQ37VHR]

Diagnostic Test Mode	KEY and ENG. Status	Function	Explanation of Function
Mode I	Ignition switch in ON position  Engine stopped 	BULB CHECK	This function checks the MIL bulb for damage (blown, open circuit, etc.). If the MIL does not illuminate, check MIL circuit.
	Engine running 	MALFUNCTION WARNING	When a malfunction is detected twice in two consecutive driving cycles (two trip detection logic), the MIL will illuminate to inform the driver that a malfunction has been detected. The following malfunctions will illuminate or blink the MIL in the 1st trip. <ul style="list-style-type: none"> • Misfire (Possible three way catalyst damage) • One trip detection diagnoses
Mode II	Ignition switch in ON position  Engine stopped 	SELF-DIAGNOSTIC RESULTS	This function allows DTCs and 1st trip DTCs to be read.

Diagnostic Test Mode I — Bulb Check

In this mode, the MIL on the instrument panel should stay ON. If it remains OFF, check the bulb. Refer to [EC-508, "Component Function Check"](#).

Diagnostic Test Mode I — Malfunction Warning

MIL	Condition
ON	When the malfunction is detected.
OFF	No malfunction.

This DTC number is clarified in Diagnostic Test Mode II (SELF-DIAGNOSTIC RESULTS)

Diagnostic Test Mode II — Self-diagnostic Results

In this mode, the DTC and 1st trip DTC are indicated by the number of blinks of the MIL as shown below. The DTC and 1st trip DTC are displayed at the same time. If the MIL does not illuminate in diagnostic test mode I (Malfunction warning), all displayed items are 1st trip DTCs. If only one code is displayed when the MIL illuminates in diagnostic test mode II (SELF-DIAGNOSTIC RESULTS), it is a DTC; if two or more codes are displayed, they may be either DTCs or 1st trip DTCs. DTC No. is same as that of 1st trip DTC. These uniden-

ON BOARD DIAGNOSTIC (OBD) SYSTEM

[VQ37VHR]

< SYSTEM DESCRIPTION >

Identified codes can be identified by using the CONSULT-III or GST. A DTC will be used as an example for how to read a code.

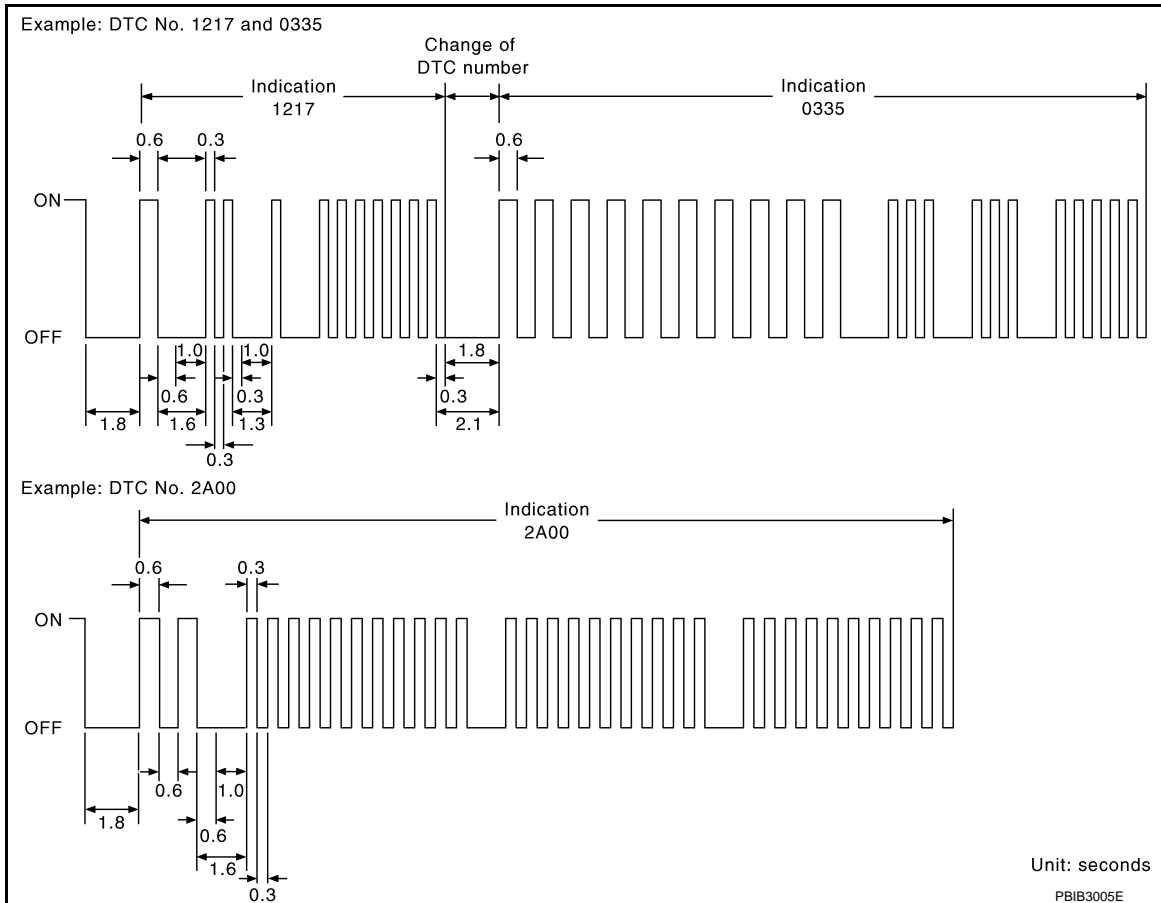

A particular trouble code can be identified by the number of four-digit numeral flashes per the following.

Number	0	1	2	3	4	5	6	7	8	9	A	B	C	D	E	F
Flashes	10	1	2	3	4	5	6	7	8	9	11	12	13	14	15	16

The length of time the 1,000th-digit numeral flashes on and off is 1.2 seconds consisting of an ON (0.6-seconds) - OFF (0.6-seconds) cycle.

The 100th-digit numeral and lower digit numerals consist of a 0.3-seconds ON and 0.3-seconds OFF cycle.

A change from one digit numeral to another occurs at an interval of 1.0-second OFF. In other words, the later numeral appears on the display 1.3 seconds after the former numeral has disappeared.

A change from one trouble code to another occurs at an interval of 1.8-seconds OFF.

In this way, all the detected malfunctions are classified by their DTC numbers. The DTC 0000 refers to no malfunction. (See [EC-557, "DTC Index"](#))

How to Switch Diagnostic Test Mode

NOTE:

- It is better to count the time accurately with a clock.
- It is impossible to switch the diagnostic mode when an accelerator pedal position sensor circuit has a malfunction.
- ECM always returns to Diagnostic Test Mode I after the ignition switch is turned OFF.

HOW TO SET DIAGNOSTIC TEST MODE II (SELF-DIAGNOSTIC RESULTS)

1. Confirm that accelerator pedal is fully released, turn ignition switch ON and wait 3 seconds.
2. Repeat the following procedure quickly five times within 5 seconds.
 - Fully depress the accelerator pedal.
 - Fully release the accelerator pedal.
3. Wait 7 seconds, fully depress the accelerator pedal and keep it depressed for approx. 10 seconds until the MIL starts blinking.

NOTE:

Do not release the accelerator pedal for 10 seconds if MIL starts blinking during this period. This blinking is displaying SRT status and is continued for another 10 seconds.

ON BOARD DIAGNOSTIC (OBD) SYSTEM

[VQ37VHR]

< SYSTEM DESCRIPTION >

4. Fully release the accelerator pedal.
ECM has entered to Diagnostic Test Mode II (Self-diagnostic results).

NOTE:

Wait until the same DTC (or 1st trip DTC) appears to completely confirm all DTCs.

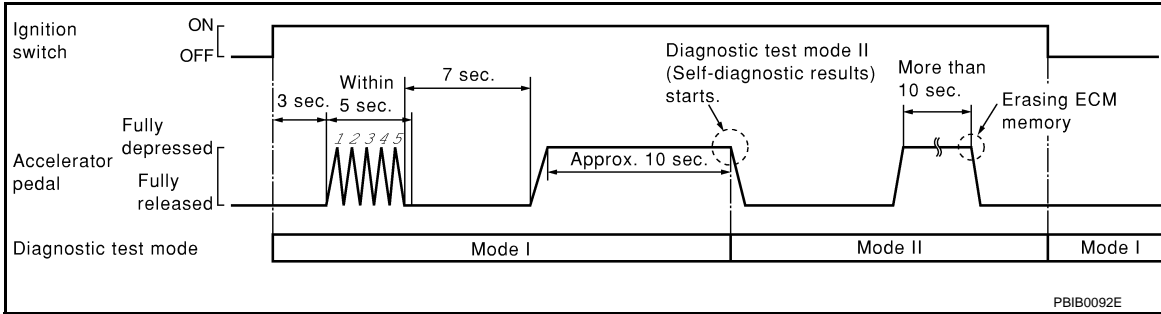

HOW TO ERASE DIAGNOSTIC TEST MODE II (SELF-DIAGNOSTIC RESULTS)

1. Set ECM in Diagnostic Test Mode II (Self-diagnostic results). Refer to “How to Set Diagnostic Test Mode II (Self-diagnostic Results)”.
2. Fully depress the accelerator pedal and keep it depressed for more than 10 seconds.
The emission-related diagnostic information has been erased from the backup memory in the ECM.
3. Fully release the accelerator pedal, and confirm the DTC 0000 is displayed.

How to Erase Diagnostic Test Mode II (Self-diagnostic Results)

The DTC can be erased from the back up memory in the ECM by depressing accelerator pedal. Refer to “How to Erase Diagnostic Test Mode II (Self-diagnostic Results)”.

- If the battery is disconnected, the DTC will be cleared from the backup memory within 24 hours.
- Be careful not to erase the stored memory before starting trouble diagnoses.

OBD SYSTEM OPERATION CHART

Relationship Between MIL, 1st Trip DTC, DTC, and Detectable Items

- When a malfunction is detected for the first time, the 1st trip DTC and the 1st trip freeze frame data are stored in the ECM memory.
- When the same malfunction is detected in two consecutive trips, the DTC and the freeze frame data are stored in the ECM memory, and the MIL will illuminate.
- The MIL will turn off after the vehicle is driven 3 times (driving pattern B) with no malfunction. A drive is counted only when the recorded driving pattern is met (as stored in the ECM). If another malfunction occurs while counting, the counter will reset.
- The DTC and the freeze frame data will be stored until the vehicle is driven 40 times (driving pattern A) without the same malfunction recurring (except for Misfire and Fuel Injection System). For Misfire and Fuel Injection System, the DTC and freeze frame data will be stored until the vehicle is driven 80 times (driving pattern C) without the same malfunction recurring. The “TIME” in “SELF-DIAGNOSTIC RESULTS” mode of CONSULT-III will count the number of times the vehicle is driven.
- The 1st trip DTC is not displayed when the self-diagnosis results in OK for the 2nd trip.

Summary Chart

Items	Fuel Injection System	Misfire	Other
MIL (turns off)	3 (pattern B)	3 (pattern B)	3 (pattern B)
DTC, Freeze Frame Data (no display)	80 (pattern C)	80 (pattern C)	40 (pattern A)
1st Trip DTC (clear)	1 (pattern C), *1	1 (pattern C), *1	1 (pattern B)
1st Trip Freeze Frame Data (clear)	*1, *2	*1, *2	1 (pattern B)

For details about patterns B and C under “Fuel Injection System” and “Misfire”, see “EXPLANATION FOR DRIVING PATTERNS FOR “MISFIRE <EXHAUST QUALITY DETERIORATION>”, “FUEL INJECTION SYSTEM”.

For details about patterns A and B under Other, see “EXPLANATION FOR DRIVING PATTERNS FOR “MISFIRE <EXHAUST QUALITY DETERIORATION>”, “FUEL INJECTION SYSTEM”.

*1: Clear timing is at the moment OK is detected.

*2: Clear timing is when the same malfunction is detected in the 2nd trip.

Relationship Between MIL, DTC, 1st Trip DTC and Driving Patterns for “Misfire <Exhaust Quality Deterioration>”,

ON BOARD DIAGNOSTIC (OBD) SYSTEM

< SYSTEM DESCRIPTION >

[VQ37VHR]

"Fuel Injection System"

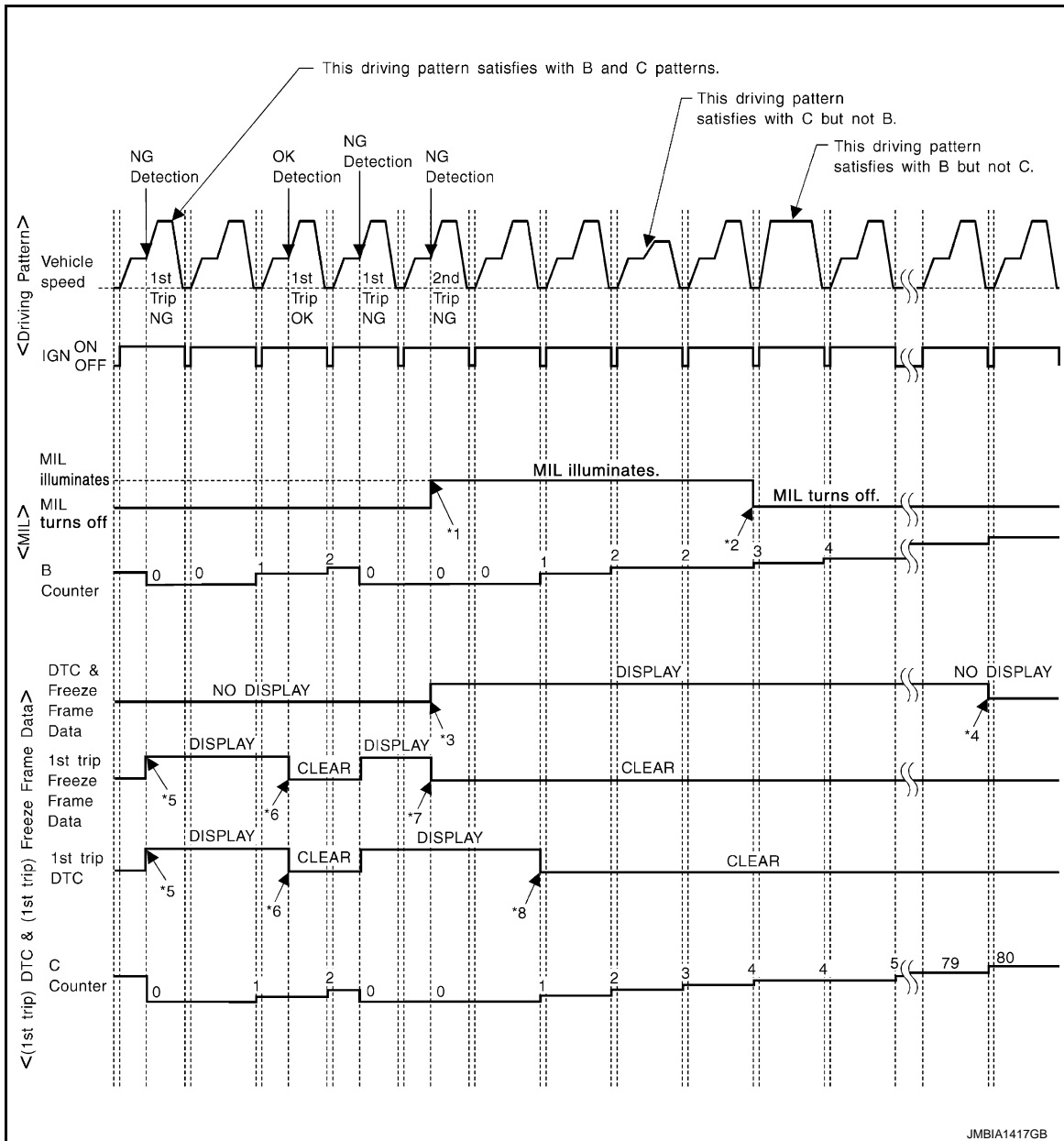

*1: When the same malfunction is detected in two consecutive trips, MIL will illuminate.

*2: MIL will turn off after vehicle is driven 3 times (pattern B) without any malfunctions.

*3: When the same malfunction is detected in two consecutive trips, the DTC and the freeze frame data will be stored in ECM.

*4: The DTC and the freeze frame data will not be displayed any longer after vehicle is driven 80 times (pattern C) without the same malfunction. (The DTC and the freeze frame data still remain in ECM.)

*5: When a malfunction is detected for the first time, the 1st trip DTC and the 1st trip freeze frame data will be stored in ECM.

*6: The 1st trip DTC and the 1st trip freeze frame data will be cleared at the moment OK is detected.

*7: When the same malfunction is detected in the 2nd trip, the 1st trip freeze frame data will be cleared.

*8: 1st trip DTC will be cleared when vehicle is driven once (pattern C) without the same malfunction after DTC is stored in ECM.

Explanation for Driving Patterns for "Misfire <Exhaust Quality Deterioration>", "Fuel Injection System" <Driving Pattern B>

Driving pattern B means the vehicle operation as per the following:

ON BOARD DIAGNOSTIC (OBD) SYSTEM

[VQ37VHR]

< SYSTEM DESCRIPTION >

All components and systems should be monitored at least once by the OBD system.

- The B counter will be cleared when the malfunction is detected once regardless of the driving pattern.
- The B counter will be counted up when driving pattern B is satisfied without any malfunction.
- The MIL will turn off when the B counter reaches 3. (*2 in "OBD SYSTEM OPERATION CHART")

<Driving Pattern C>

Driving pattern C means operating vehicle as per the following:

The following conditions should be satisfied at the same time:

Engine speed: (Engine speed in the freeze frame data) ± 375 rpm

Calculated load value: (Calculated load value in the freeze frame data) $\times (1 \pm 0.1)$ [%]

Engine coolant temperature (T) condition:

- When the freeze frame data shows lower than 70°C (158°F), T should be lower than 70°C (158°F).
- When the freeze frame data shows higher than or equal to 70°C (158°F), T should be higher than or equal to 70°C (158°F).

Example:

If the stored freeze frame data is as per the following:

Engine speed: 850 rpm, Calculated load value: 30%, Engine coolant temperature: 80°C (176°F)

To be satisfied with driving pattern C, the vehicle should run under the following conditions:

Engine speed: 475 - 1,225 rpm, Calculated load value: 27 - 33%, Engine coolant temperature: more than 70°C (158°F)

- The C counter will be cleared when the malfunction is detected regardless of vehicle conditions above.
- The C counter will be counted up when vehicle conditions above are satisfied without the same malfunction.
- The DTC will not be displayed after C counter reaches 80.
- The 1st trip DTC will be cleared when C counter is counted once without the same malfunction after DTC is stored in ECM.

Relationship Between MIL, DTC, 1st Trip DTC and Driving Patterns Except For "Misfire <Exhaust Quality Deterioration>", "Fuel Injection System"

ON BOARD DIAGNOSTIC (OBD) SYSTEM

< SYSTEM DESCRIPTION >

[VQ37VHR]

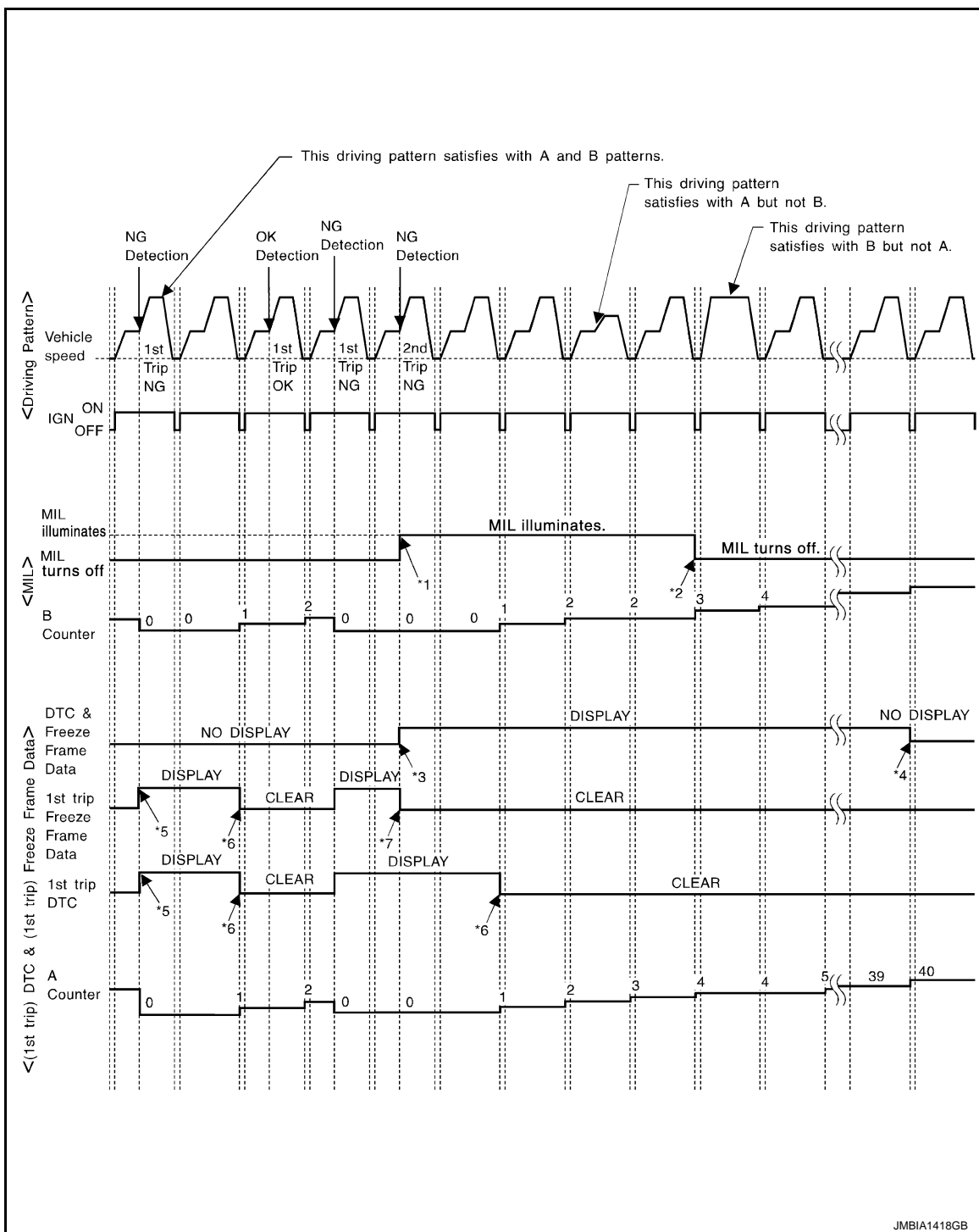

*1: When the same malfunction is detected in two consecutive trips, MIL will illuminate.

*2: MIL will turn off after vehicle is driven 3 times (pattern B) without any malfunctions.

*3: When the same malfunction is detected in two consecutive trips, the DTC and the freeze frame data will be stored in ECM.

ON BOARD DIAGNOSTIC (OBD) SYSTEM

[VQ37VHR]

< SYSTEM DESCRIPTION >

*4: The DTC and the freeze frame data will not be displayed any longer after vehicle is driven 40 times (pattern A) without the same malfunction.
(The DTC and the freeze frame data still remain in ECM.)

*7: When the same malfunction is detected in the 2nd trip, the 1st trip freeze frame data will be cleared.

*5: When a malfunction is detected for the first time, the 1st trip DTC and the 1st trip freeze frame data will be stored in ECM.

*6: 1st trip DTC will be cleared after vehicle is driven once (pattern B) without the same malfunction.

Explanation for Driving Patterns Except for "Misfire <Exhaust Quality Deterioration>", "Fuel Injection System" <Driving Pattern A>

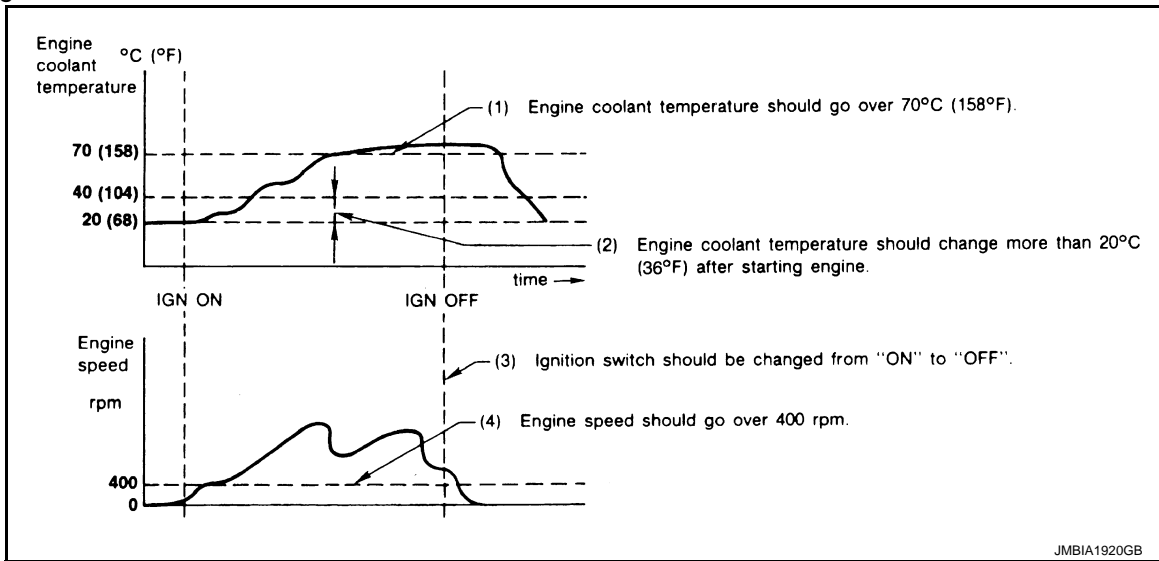

- The A counter will be cleared when the malfunction is detected regardless of (1) - (4).
- The A counter will be counted up when (1) - (4) are satisfied without the same malfunction.
- The DTC will not be displayed after the A counter reaches 40.

<Driving Pattern B>

Driving pattern B means operating vehicle as per the following:

All components and systems should be monitored at least once by the OBD system.

- The B counter will be cleared when the malfunction is detected once regardless of the driving pattern.
- The B counter will be counted up when driving pattern B is satisfied without any malfunctions.
- The MIL will turn off when the B counter reaches 3 (*2 in OBD SYSTEM OPERATION CHART).

CONSULT-III Function

INFOID:000000005151680

FUNCTION

Diagnostic test mode	Function
Work support	This mode enables a technician to adjust some devices faster and more accurately by following the indications on the CONSULT-III unit.
Self-diagnostic results	Self-diagnostic results such as 1st trip DTC, DTCs and 1st trip freeze frame data or freeze frame data can be read and erased quickly.*
Data monitor	Input/Output data in the ECM can be read.
CAN diagnostic support monitor	The results of transmit/receive diagnosis of CAN communication can be read.
Active test	Diagnostic Test Mode in which CONSULT-III drives some actuators apart from the ECMs and also shifts some parameters in a specified range.
DTC & SRT confirmation	The status of system monitoring tests and the self-diagnosis status/results can be confirmed.
Function test	This mode is used to inform customers when the vehicle requires periodic maintenance.
ECU identification	ECM part number can be read.

*: The following emission-related diagnostic information is cleared when the ECM memory is erased.

- Diagnostic trouble codes

ON BOARD DIAGNOSTIC (OBD) SYSTEM

[VQ37VHR]

< SYSTEM DESCRIPTION >

- 1st trip diagnostic trouble codes
- Freeze frame data
- 1st trip freeze frame data
- System readiness test (SRT) codes
- Test values

A

EC

ENGINE CONTROL COMPONENT PARTS/CONTROL SYSTEMS APPLICATION

Item		DIAGNOSTIC TEST MODE						
		WORK SUPPORT	SELF-DIAGNOSTIC RESULTS		DATA MONITOR	ACTIVE TEST	DTC & SRT CONFIRMATION	
			DTC*1	FREEZE FRAME DATA*2			SRT STATUS	DTC WORK SUPPORT
ENGINE CONTROL COMPONENT PARTS	INPUT	Crankshaft position sensor (POS)	×	×	×			
	Camshaft position sensor (PHASE)	×	×	×				
	Mass air flow sensor	×		×				
	Engine coolant temperature sensor	×	×	×	×			
	Engine oil temperature sensor	×		×				
	Air fuel ratio (A/F) sensor 1	×		×		×	×	
	Heated oxygen sensor 2	×		×		×	×	
	Vehicle speed signal	×	×	×				
	Accelerator pedal position sensor	×		×				
	Throttle position sensor	×	×	×				
	Fuel tank temperature sensor	×		×	×			
	EVAP control system pressure sensor	×		×				
	Intake air temperature sensor	×	×	×				
	Knock sensor	×						
	Refrigerant pressure sensor				×			
	Closed throttle position switch (accelerator pedal position sensor signal)				×			
	Air conditioner switch				×			
	Park/neutral position (PNP) signal	×		×				
	Stop lamp switch	×		×				
	Power steering pressure sensor	×		×				
	Battery voltage				×			
	Load signal				×			
	Fuel level sensor	×		×				
	Battery current sensor	×		×				
	ICC steering switch	×		×				
	ASCD steering switch	×		×				
	ICC brake switch	×		×				
	ASCD brake switch	×		×				
VVEL control shaft position sensor	×		×					
Manifold absolute pressure (MAP) sensor	×							
Brake booster pressure sensor	×							

C

D

E

F

G

H

I

J

K

L

M

N

O

P

ON BOARD DIAGNOSTIC (OBD) SYSTEM

< SYSTEM DESCRIPTION >

[VQ37VHR]

Item		DIAGNOSTIC TEST MODE							
		WORK SUPPORT	SELF-DIAGNOSTIC RESULTS		DATA MONITOR	ACTIVE TEST	DTC & SRT CONFIRMATION		
			DTC*1	FREEZE FRAME DATA*2			SRT STATUS	DTC WORK SUPPORT	
ENGINE CONTROL COMPONENT PARTS	OUTPUT	Fuel injector				×	×		
		Power transistor (Ignition timing)				×	×		
		Throttle control motor relay		×		×			
		Throttle control motor		×					
		EVAP canister purge volume control solenoid valve		×		×	×		×
		Air conditioner relay				×			
		Fuel pump relay	×			×	×		
		Cooling fan control module		×		×	×		
		Air fuel ratio (A/F) sensor 1 heater		×		×		×*3	
		Heated oxygen sensor 2 heater		×		×		×*3	
		EVAP canister vent control valve	×	×		×	×		
		Intake valve timing control solenoid valve		×		×	×		
		VVEL actuator motor relay		×					
		VVEL actuator motor	×	×					
		Alternator				×	×		
	Calculated load value			×	×				

×: Applicable

*1: This item includes 1st trip DTCs.

*2: This mode includes 1st trip freeze frame data or freeze frame data. The items appear on CONSULT-III screen in freeze frame data mode only if a 1st trip DTC or DTC is detected. For details, refer to [EC-107, "Diagnosis Description"](#).

*3: Always "CMPLT" is displayed.

WORK SUPPORT MODE

Work Item

ON BOARD DIAGNOSTIC (OBD) SYSTEM

< SYSTEM DESCRIPTION >

[VQ37VHR]

WORK ITEM	CONDITION	USAGE
IDLE AIR VOL LEARN	<ul style="list-style-type: none"> • THE IDLE AIR VOLUME THAT KEEPS THE ENGINE WITHIN THE SPECIFIED RANGE IS MEMORIZED IN ECM. 	When learning the idle air volume
EVAP SYSTEM CLOSE	<p>CLOSE THE EVAP CANISTER VENT CONTROL VALVE IN ORDER TO MAKE EVAP SYSTEM CLOSE UNDER THE FOLLOWING CONDITIONS.</p> <ul style="list-style-type: none"> • IGN SW ON • ENGINE NOT RUNNING • AMBIENT TEMPERATURE IS ABOVE 0°C (32°F). • NO VACUUM AND NO HIGH PRESSURE IN EVAP SYSTEM • FUEL TANK TEMP. IS MORE THAN 0°C (32°F). • WITHIN 10 MINUTES AFTER STARTING "EVAP SYSTEM CLOSE" • WHEN TRYING TO EXECUTE "EVAP SYSTEM CLOSE" UNDER THE CONDITION EXCEPT ABOVE, CONSULT-III WILL DISCONTINUE IT AND DISPLAY APPROPRIATE INSTRUCTION. <p>NOTE: WHEN STARTING ENGINE, CONSULT-III MAY DISPLAY "BATTERY VOLTAGE IS LOW. CHARGE BATTERY", EVEN WHEN USING A CHARGED BATTERY.</p>	When detecting EVAP vapor leak in the EVAP system
FUEL PRESSURE RELEASE	<ul style="list-style-type: none"> • FUEL PUMP WILL STOP BY TOUCHING "START" DURING IDLING. • CRANK A FEW TIMES AFTER ENGINE STALLS. 	When releasing fuel pressure from fuel line
SELF-LEARNING CONT	<ul style="list-style-type: none"> • THE COEFFICIENT OF SELF-LEARNING CONTROL MIXTURE RATIO RETURNS TO THE ORIGINAL COEFFICIENT. 	When clearing mixture ratio self-learning value
TARGET IDLE RPM ADJ*	<ul style="list-style-type: none"> • IDLE CONDITION 	When setting target idle speed
TARGET IGN TIM ADJ*	<ul style="list-style-type: none"> • IDLE CONDITION 	When adjusting target ignition timing
VIN REGISTRATION	<ul style="list-style-type: none"> • IN THIS MODE, VIN IS REGISTERED IN ECM. 	When registering VIN in ECM
VVEL POS SEN ADJ PREP	<ul style="list-style-type: none"> • USE THIS ITEM ONLY WHEN REPLACING VVEL ACTUATOR SUB ASSEMBLY. • IGNITION ON AND ENGINE STOPPED. 	When adjusting VVEL control shaft position sensor

*: This function is not necessary in the usual service procedure.

SELF-DIAG RESULTS MODE

Self Diagnostic Item

Regarding items of DTC and 1st trip DTC, refer to [EC-557, "DTC Index".](#))

Freeze Frame Data and 1st Trip Freeze Frame Data

Freeze frame data item*	Description
DIAG TROUBLE CODE [PXXXX]	<ul style="list-style-type: none"> • The engine control component part/control system has a trouble code that is displayed as PXXXX. (Refer to EC-557, "DTC Index".)
CAL/LD VALUE [%]	<ul style="list-style-type: none"> • The calculated load value at the moment a malfunction is detected is displayed.
COOLANT TEMP [°C] or [°F]	<ul style="list-style-type: none"> • The engine coolant temperature at the moment a malfunction is detected is displayed.
L-FUEL TRM-B1 [%]	<ul style="list-style-type: none"> • "Long-term fuel trim" at the moment a malfunction is detected is displayed.
L-FUEL TRM-B2 [%]	<ul style="list-style-type: none"> • The long-term fuel trim indicates much more gradual feedback compensation to the base fuel schedule than short-term fuel trim.
S-FUEL TRM-B1 [%]	<ul style="list-style-type: none"> • "Short-term fuel trim" at the moment a malfunction is detected is displayed.
S-FUEL TRM-B2 [%]	<ul style="list-style-type: none"> • The short-term fuel trim indicates dynamic or instantaneous feedback compensation to the base fuel schedule.

ON BOARD DIAGNOSTIC (OBD) SYSTEM

[VQ37VHR]

< SYSTEM DESCRIPTION >

Freeze frame data item*	Description
ENGINE SPEED [rpm]	<ul style="list-style-type: none"> The engine speed at the moment a malfunction is detected is displayed
VEHICL SPEED [km/h] or [mph]	<ul style="list-style-type: none"> The vehicle speed at the moment a malfunction is detected is displayed
ABSOL TH-P/S [%]	<ul style="list-style-type: none"> The throttle valve opening angle at the moment a malfunction is detected is displayed
B/FUEL SCHDL [msec]	<ul style="list-style-type: none"> The base fuel schedule at the moment a malfunction is detected is displayed
INT/A TEMP SE [°C] or [°F]	<ul style="list-style-type: none"> The intake air temperature at the moment a malfunction is detected is displayed
FUEL SYS-B1	<ul style="list-style-type: none"> "Fuel injection system status" at the moment a malfunction is detected is displayed. One of the following mode is displayed. Mode2: Open loop due to detected system malfunction Mode3: Open loop due to driving conditions (power enrichment, deceleration enrichment) Mode4: Closed loop - using oxygen sensor(s) as feedback for fuel control Mode5: Open loop - has not yet satisfied condition to go to closed loop
FUEL SYS-B2	
INT MANI PRES [kPa]	<ul style="list-style-type: none"> These items are displayed but are not applicable to this model.
COMBUST CONDI-TION	

*: The items are the same as those of 1st trip freeze frame data.

DATA MONITOR MODE

Monitored Item

x: Applicable

Monitored item	Unit	Description	Remarks
ENG SPEED	rpm	<ul style="list-style-type: none"> Indicates the engine speed computed from the signal of the crankshaft position sensor (POS) and camshaft position sensor (PHASE). 	<ul style="list-style-type: none"> Accuracy becomes poor if engine speed drops below the idle rpm. If the signal is interrupted while the engine is running, an abnormal value may be indicated.
MAS A/F SE-B1	V	<ul style="list-style-type: none"> The signal voltage of the mass air flow sensor is displayed. 	<ul style="list-style-type: none"> When the engine is stopped, a certain value is indicated. When engine is running, specification range is indicated in "SPEC".
MAS A/F SE-B2			
B/FUEL SCHDL	msec	<ul style="list-style-type: none"> "Base fuel schedule" indicates the fuel injection pulse width programmed into ECM, prior to any learned on board correction. 	<ul style="list-style-type: none"> When engine is running, specification range is indicated in "SPEC".
A/F ALPHA-B1	%	<ul style="list-style-type: none"> The mean value of the air-fuel ratio feedback correction factor per cycle is indicated. 	<ul style="list-style-type: none"> When the engine is stopped, a certain value is indicated. This data also includes the data for the air-fuel ratio learning control. When engine is running, specification range is indicated in "SPEC".
A/F ALPHA-B2			
COOLAN TEMP/S	°C or °F	<ul style="list-style-type: none"> The engine coolant temperature (determined by the signal voltage of the engine coolant temperature sensor) is displayed. 	<ul style="list-style-type: none"> When the engine coolant temperature sensor is open or short-circuited, ECM enters fail-safe mode. The engine coolant temperature determined by the ECM is displayed.
A/F SEN1 (B1)	V	<ul style="list-style-type: none"> The A/F signal computed from the input signal of the air fuel ratio (A/F) sensor 1 is displayed. 	
A/F SEN1 (B2)			
HO2S2 (B1)	V	<ul style="list-style-type: none"> The signal voltage of the heated oxygen sensor 2 is displayed. 	
HO2S2 (B2)			
HO2S2 MNTR (B1)	RICH/LEAN	<ul style="list-style-type: none"> Display of heated oxygen sensor 2 signal: RICH: means the amount of oxygen after three way catalyst is relatively small. LEAN: means the amount of oxygen after three way catalyst is relatively large. 	<ul style="list-style-type: none"> When the engine is stopped, a certain value is indicated.
HO2S2 MNTR (B2)			

ON BOARD DIAGNOSTIC (OBD) SYSTEM

[VQ37VHR]

< SYSTEM DESCRIPTION >

Monitored item	Unit	Description	Remarks
VHCL SPEED SE	km/h or mph	<ul style="list-style-type: none"> The vehicle speed computed from the vehicle speed signal sent from combination meter is displayed. 	
BATTERY VOLT	V	<ul style="list-style-type: none"> The power supply voltage of ECM is displayed. 	
ACCEL SEN 1	V	<ul style="list-style-type: none"> The accelerator pedal position sensor signal voltage is displayed. 	<ul style="list-style-type: none"> ACCEL SEN 2 signal is converted by ECM internally. Thus, they differs from ECM terminal voltage signal.
ACCEL SEN 2			
TP SEN 1-B1	V	<ul style="list-style-type: none"> The throttle position sensor signal voltage is displayed. 	<ul style="list-style-type: none"> TP SEN 2-B1 signal is converted by ECM internally. Thus, they differs from ECM terminal voltage signal.
TP SEN 2-B1			
FUEL T/TMP SE	°C or °F	<ul style="list-style-type: none"> The fuel temperature (determined by the signal voltage of the fuel tank temperature sensor) is displayed. 	
INT/A TEMP SE	°C or °F	<ul style="list-style-type: none"> The intake air temperature (determined by the signal voltage of the intake air temperature sensor) is indicated. 	
EVAP SYS PRES	V	<ul style="list-style-type: none"> The signal voltage of EVAP control system pressure sensor is displayed. 	
FUEL LEVEL SE	V	<ul style="list-style-type: none"> The signal voltage of the fuel level sensor is displayed. 	
START SIGNAL	ON/OFF	<ul style="list-style-type: none"> Indicates start signal status [ON/OFF] computed by the ECM according to the signals of engine speed and battery voltage. 	<ul style="list-style-type: none"> After starting the engine, [OFF] is displayed regardless of the starter signal.
CLSD THL POS	ON/OFF	<ul style="list-style-type: none"> Indicates idle position [ON/OFF] computed by ECM according to the accelerator pedal position sensor signal. 	
AIR COND SIG	ON/OFF	<ul style="list-style-type: none"> Indicates [ON/OFF] condition of the air conditioner switch as determined by the air conditioner signal. 	
P/N POSI SW	ON/OFF	<ul style="list-style-type: none"> Indicates [ON/OFF] condition from the park/neutral position (PNP) switch signal (M/T) or transmission range switch signal (A/T). 	
PW/ST SIGNAL	ON/OFF	<ul style="list-style-type: none"> [ON/OFF] condition of the power steering system (determined by the signal voltage of the power steering pressure sensor signal) is indicated. 	
LOAD SIGNAL	ON/OFF	<ul style="list-style-type: none"> Indicates [ON/OFF] condition from the electrical load signal. ON: Rear window defogger switch is ON and/or lighting switch is in 2nd position. OFF: Both rear window defogger switch and lighting switch are OFF. 	
IGNITION SW	ON/OFF	<ul style="list-style-type: none"> Indicates [ON/OFF] condition from ignition switch signal. 	
HEATER FAN SW	ON/OFF	<ul style="list-style-type: none"> Indicates [ON/OFF] condition from the heater fan switch signal. 	
BRAKE SW	ON/OFF	<ul style="list-style-type: none"> Indicates [ON/OFF] condition from the stop lamp switch signal. 	
INJ PULSE-B1	msec	<ul style="list-style-type: none"> Indicates the actual fuel injection pulse width compensated by ECM according to the input signals. 	<ul style="list-style-type: none"> When the engine is stopped, a certain computed value is indicated.
INJ PULSE-B2			
IGN TIMING	BTDC	<ul style="list-style-type: none"> Indicates the ignition timing computed by ECM according to the input signals. 	<ul style="list-style-type: none"> When the engine is stopped, a certain value is indicated.
CAL/LD VALUE	%	<ul style="list-style-type: none"> "Calculated load value" indicates the value of the current air flow divided by peak air flow. 	

A

EC

C

D

E

F

G

H

I

J

K

L

M

N

O

P

ON BOARD DIAGNOSTIC (OBD) SYSTEM

[VQ37VHR]

< SYSTEM DESCRIPTION >

Monitored item	Unit	Description	Remarks
MASS AIRFLOW	g-m/s	<ul style="list-style-type: none"> Indicates the mass air flow computed by ECM according to the signal voltage of the mass air flow sensor. 	
PURG VOL C/V	%	<ul style="list-style-type: none"> Indicates the EVAP canister purge volume control solenoid valve control value computed by the ECM according to the input signals. The opening becomes larger as the value increases. 	
INT/V TIM (B1)	°CA	<ul style="list-style-type: none"> Indicates [°CA] of intake camshaft advance angle. 	
INT/V TIM (B2)			
INT/V SOL (B1)	%	<ul style="list-style-type: none"> The control value of the intake valve timing control solenoid valve (determined by ECM according to the input signals) is indicated. The advance angle becomes larger as the value increases. 	
INT/V SOL (B2)			
TP SEN 1-B2	V	<ul style="list-style-type: none"> The throttle position sensor signal voltage is displayed. 	<ul style="list-style-type: none"> TP SEN 2-B2 signal is converted by ECM internally. Thus, they differs from ECM terminal voltage signal.
TP SEN 2-B2			
AIR COND RLY	ON/OFF	<ul style="list-style-type: none"> The air conditioner relay control condition (determined by ECM according to the input signals) is indicated. 	
FUEL PUMP RLY	ON/OFF	<ul style="list-style-type: none"> Indicates the fuel pump relay control condition determined by ECM according to the input signals. 	
VENT CONT/V	ON/OFF	<ul style="list-style-type: none"> The control condition of the EVAP canister vent control valve (determined by ECM according to the input signals) is indicated. ON: Closed OFF: Open 	
THRTL RELAY	ON/OFF	<ul style="list-style-type: none"> Indicates the throttle control motor relay control condition determined by the ECM according to the input signals. 	
HO2S2 HTR (B1)	ON/OFF	<ul style="list-style-type: none"> Indicates [ON/OFF] condition of heated oxygen sensor 2 heater determined by ECM according to the input signals. 	
HO2S2 HTR (B2)			
VEHICLE SPEED	km/h or mph	<ul style="list-style-type: none"> The vehicle speed computed from the vehicle speed signal sent from TCM is displayed. 	
IDL A/V LEARN	YET/CMPLT	<ul style="list-style-type: none"> Displays the condition of Idle Air Volume Learning YET: Idle air volume learning has not been performed yet. CMPLT: Idle air volume learning has already been performed successfully. 	
ENG OIL TEMP	°C or °F	<ul style="list-style-type: none"> The engine oil temperature (determined by the signal voltage of the engine oil temperature sensor) is displayed. 	
TRVL AFTER MIL	km or mile	<ul style="list-style-type: none"> Distance traveled while MIL is activated. 	
A/F S1 HTR (B1)	%	<ul style="list-style-type: none"> Air fuel ratio (A/F) sensor 1 heater control value computed by ECM according to the input signals. The current flow to the heater becomes larger as the value increases. 	
A/F S1 HTR (B2)			
AC PRESS SEN	V	<ul style="list-style-type: none"> The signal voltage from the refrigerant pressure sensor is displayed. 	
VHCL SPEED SE	km/h or mph	<ul style="list-style-type: none"> The vehicle speed computed from the vehicle speed signal sent from combination meter is displayed. 	
SET VHCL SPD	km/h or mph	<ul style="list-style-type: none"> The preset vehicle speed is displayed. 	

ON BOARD DIAGNOSTIC (OBD) SYSTEM

< SYSTEM DESCRIPTION >

[VQ37VHR]

Monitored item	Unit	Description	Remarks
MAIN SW	ON/OFF	<ul style="list-style-type: none"> Indicates [ON/OFF] condition from MAIN switch signal. 	
CANCEL SW	ON/OFF	<ul style="list-style-type: none"> Indicates [ON/OFF] condition from CANCEL switch signal. 	
RESUME/ACC SW	ON/OFF	<ul style="list-style-type: none"> Indicates [ON/OFF] condition from RESUME/ACCELERATE switch signal. 	
SET SW	ON/OFF	<ul style="list-style-type: none"> Indicates [ON/OFF] condition from SET/COAST switch signal. 	
BRAKE SW1	ON/OFF	<ul style="list-style-type: none"> Indicates [ON/OFF] condition from ASCD brake switch signal. 	
BRAKE SW2	ON/OFF	<ul style="list-style-type: none"> Indicates [ON/OFF] condition of stop lamp switch signal. 	
VHCL SPD CUT	NON/CUT	<ul style="list-style-type: none"> Indicates the vehicle cruise condition. NON: Vehicle speed is maintained at the ASCD set speed. CUT: Vehicle speed decreased to excessively low compared with the ASCD set speed, and ASCD operation is cut off. 	
LO SPEED CUT	NON/CUT	<ul style="list-style-type: none"> Indicates the vehicle cruise condition. NON: Vehicle speed is maintained at the ASCD set speed. CUT: Vehicle speed decreased to excessively low and ASCD operation is cut off. 	
CRUISE LAMP	ON/OFF	<ul style="list-style-type: none"> Indicates [ON/OFF] condition of CRUISE lamp determined by the ECM according to the input signals. 	
SET LAMP	ON/OFF	<ul style="list-style-type: none"> Indicates [ON/OFF] condition of SET lamp determined by the ECM according to the input signals. 	
AT OD MONITOR	ON/OFF	<ul style="list-style-type: none"> Indicates [ON/OFF] condition of A/T O/D according to the input signal from the TCM. 	
AT OD CANCEL	ON/OFF	<ul style="list-style-type: none"> Indicates [ON/OFF] condition of A/T O/D cancel request signal from the TCM. 	
BAT CUR SEN	mV	<ul style="list-style-type: none"> The signal voltage of battery current sensor is displayed. 	
ALT DUTY SIG	ON/OFF	<ul style="list-style-type: none"> The control condition of the power generation voltage variable control (determined by ECM according to the input signals) is indicated. ON: Power generation voltage variable control is active. OFF: Power generation voltage variable control is inactive. 	
A/F ADJ-B1	—	<ul style="list-style-type: none"> Indicates the correction of factor stored in ECM. The factor is calculated from the difference between the target air-fuel ratio stored in ECM and the air-fuel ratio calculated from A/F sensor 1 signal. 	
A/F ADJ-B2			
FAN DUTY	%	<ul style="list-style-type: none"> Indicates a command value for cooling fan. The value is calculated by ECM based on input signals. 	
AC EVA TEMP	°C or °F	<ul style="list-style-type: none"> Indicates A/C evaporator temperature sent from "unified meter and A/C amp." 	
AC EVA TARGET	°C or °F	<ul style="list-style-type: none"> Indicates target A/C evaporator temperature sent from "unified meter and A/C amp." 	
ALTDUTY	%	<ul style="list-style-type: none"> Indicates the duty ratio of the power generation command value. The ratio is calculated by ECM based on the battery current sensor signal. 	

A

EC

C

D

E

F

G

H

I

J

K

L

M

N

O

P

ON BOARD DIAGNOSTIC (OBD) SYSTEM

< SYSTEM DESCRIPTION >

[VQ37VHR]

Monitored item	Unit	Description	Remarks
ATOM PRES SEN	mV	<ul style="list-style-type: none"> Always a certain value is displayed. This item is not efficient for CV36 models. 	
BRAKE BST PRES SE	mV	<ul style="list-style-type: none"> Always a certain value is displayed. This item is not efficient for CV36 models. 	
VVEL SEN LEARN-B1	V	<ul style="list-style-type: none"> Indicates the VVEL learning value. 	
VVEL SEN LEARN-B2			
VVEL POSITION SEN-B1	V	<ul style="list-style-type: none"> The VVEL control shaft position sensor signal voltage is displayed. 	
VVEL POSITION SEN-B2			
VVEL TIM-B1	deg	<ul style="list-style-type: none"> Indicates [deg] of VVEL control shaft angle. 	
VVEL TIM-B2			
VVEL LEARN	YET/DONE	<ul style="list-style-type: none"> Display the condition of VVEL learning YET: VVEL learning has not been performed yet. DONE: VVEL learning has already been performed successfully. 	

NOTE:

Any monitored item that does not match the vehicle being diagnosed is deleted from the display automatically.

ACTIVE TEST MODE

Test Item

TEST ITEM	CONDITION	JUDGEMENT	CHECK ITEM (REMEDY)
POWER BALANCE	<ul style="list-style-type: none"> Engine: After warming up, idle the engine. A/C switch OFF Selector lever: P or N (A/T), Neutral (M/T) Cut off each injector signal one at a time using CONSULT-III. 	Engine runs rough or dies.	<ul style="list-style-type: none"> Harness and connectors Compression Fuel injector Power transistor Spark plug Ignition coil
VENT CONTROL/V	<ul style="list-style-type: none"> Ignition switch: ON (Engine stopped) Turn solenoid valve ON and OFF with the CONSULT-III and listen to operating sound. 	Solenoid valve makes an operating sound.	<ul style="list-style-type: none"> Harness and connectors Solenoid valve
ENG COOLANT TEMP	<ul style="list-style-type: none"> Engine: Return to the original trouble condition Change the engine coolant temperature using CONSULT-III. 	If trouble symptom disappears, see CHECK ITEM.	<ul style="list-style-type: none"> Harness and connectors Engine coolant temperature sensor Fuel injector
FUEL INJECTION	<ul style="list-style-type: none"> Engine: Return to the original trouble condition Change the amount of fuel injection using CONSULT-III. 	If trouble symptom disappears, see CHECK ITEM.	<ul style="list-style-type: none"> Harness and connectors Fuel injector Air fuel ratio (A/F) sensor 1
FUEL/T TEMP SEN	<ul style="list-style-type: none"> Change the fuel tank temperature using CONSULT-III. 		
PURG VOL CONT/V	<ul style="list-style-type: none"> Engine: After warming up, run engine at 1,500 rpm. Change the EVAP canister purge volume control solenoid valve opening percent using CONSULT-III. 	Engine speed changes according to the opening percent.	<ul style="list-style-type: none"> Harness and connectors Solenoid valve

ON BOARD DIAGNOSTIC (OBD) SYSTEM

< SYSTEM DESCRIPTION >

[VQ37VHR]

TEST ITEM	CONDITION	JUDGEMENT	CHECK ITEM (REMEDY)
FUEL PUMP RELAY	<ul style="list-style-type: none"> Ignition switch: ON (Engine stopped) Turn the fuel pump relay ON and OFF using CONSULT-III and listen to operating sound. 	Fuel pump relay makes the operating sound.	<ul style="list-style-type: none"> Harness and connectors Fuel pump relay
IGNITION TIMING	<ul style="list-style-type: none"> Engine: Return to the original trouble condition Timing light: Set Retard the ignition timing using CONSULT-III. 	If trouble symptom disappears, see CHECK ITEM.	<ul style="list-style-type: none"> Perform Idle Air Volume Learning.
FAN DUTY CONTROL*	<ul style="list-style-type: none"> Ignition switch: ON Change duty ratio using CONSULT-III. 	Cooling fan speed changes.	<ul style="list-style-type: none"> Harness and connectors Cooling fan motor Cooling fan relay Cooling fan control module IPDM E/R
ALTERNATOR DUTY	<ul style="list-style-type: none"> Engine: Idle Change duty ratio using CONSULT-III. 	Battery voltage changes.	<ul style="list-style-type: none"> Harness and connectors IPDM E/R Alternator
V/T ASSIGN ANGLE	<ul style="list-style-type: none"> Engine: Return to the original trouble condition Change the engine coolant temperature using CONSULT-III. 	If trouble symptom disappears, see CHECK ITEM.	<ul style="list-style-type: none"> Harness and connectors Engine coolant temperature sensor Fuel injector

*: Leaving cooling fan OFF with CONSULT-III while engine is running may cause the engine to overheat.

DTC & SRT CONFIRMATION MODE

SRT STATUS Mode

For details, refer to [EC-107, "Diagnosis Description"](#).

SRT WORK SUPPORT Mode

This mode enables a technician to drive a vehicle to set the SRT while monitoring the SRT status.

DTC WORK SUPPORT Mode

Test mode	Test item	Corresponding DTC No.	Reference page
EVAPORATIVE SYSTEM	EVP SML LEAK P0442/P1442*	P0442	EC-287
		P0455	EC-323
	EVP V/S LEAK P0456/P1456*	P0456	EC-329
	PURG VOL CN/V P1444	P0443	EC-293
	PURG FLOW P0441	P0441	EC-282
A/F SEN1	A/F SEN1 (B1) P1278/P1279	P0133	EC-211
	A/F SEN1 (B1) P1276	P0130	EC-201
	A/F SEN1 (B2) P1288/P1289	P0153	EC-211
	A/F SEN1 (B2) P1286	P0150	EC-201
HO2S2	HO2S2 (B1) P1146	P0138	EC-222
	HO2S2 (B1) P1147	P0137	EC-216
	HO2S2 (B1) P0139	P0139	EC-230
	HO2S2 (B2) P1166	P0158	EC-222
	HO2S2 (B2) P1167	P0157	EC-216
	HO2S2 (B2) P0159	P0159	EC-230

*: DTC P1442 and P1456 does not apply to CV36 models but appears in DTC Work Support Mode screens.

Diagnosis Tool Function

INFOID:000000005151681

DESCRIPTION

ON BOARD DIAGNOSTIC (OBD) SYSTEM

[VQ37VHR]

< SYSTEM DESCRIPTION >

Generic Scan Tool (OBDII scan tool) complying with SAE J1978 has several functions explained below. ISO15765-4 is used as the protocol. The name GST or Generic Scan Tool is used in this service manual.

Generic Scan Tool (GST): Sample

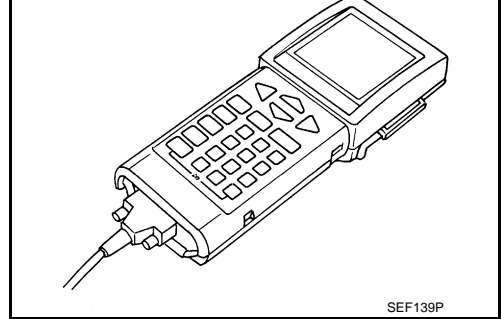

FUNCTION

Diagnostic Service		Function
Service \$01	READINESS TESTS	This diagnostic service gains access to current emission-related data values, including analog inputs and outputs, digital inputs and outputs, and system status information.
Service \$02	(FREEZE DATA)	This diagnostic service gains access to emission-related data value which were stored by ECM during the freeze frame. For details, refer to EC-557, "DTC Index" .
Service \$03	DTCs	This diagnostic service gains access to emission-related power train trouble codes which were stored by ECM.
Service \$04	CLEAR DIAG INFO	This diagnostic service can clear all emission-related diagnostic information. This includes: <ul style="list-style-type: none"> • Clear number of diagnostic trouble codes (Service \$01) • Clear diagnostic trouble codes (Service \$03) • Clear trouble code for freeze frame data (Service \$01) • Clear freeze frame data (Service \$02) • Reset status of system monitoring test (Service \$01) • Clear on board monitoring test results (Service \$06 and \$07)
Service \$06	(ON BOARD TESTS)	This diagnostic service accesses the results of on board diagnostic monitoring tests of specific components/systems that are not continuously monitored.
Service \$07	(ON BOARD TESTS)	This diagnostic service enables the off board test drive to obtain test results for emission-related powertrain components/systems that are continuously monitored during normal driving conditions.
Service \$08	—	This diagnostic service can close EVAP system in ignition switch ON position (Engine stopped). When this diagnostic service is performed, EVAP canister vent control valve can be closed. In the following conditions, this diagnostic service cannot function. <ul style="list-style-type: none"> • Low ambient temperature • Low battery voltage • Engine running • Ignition switch OFF • Low fuel temperature • Too much pressure is applied to EVAP system
Service \$09	(CALIBRATION ID)	This diagnostic service enables the off-board test device to request specific vehicle information such as Vehicle Identification Number (VIN) and Calibration IDs.

INSPECTION PROCEDURE

1. Turn ignition switch OFF.
2. Connect "GST" to data link connector (1), which is located under LH dash panel near the hood opener handle.

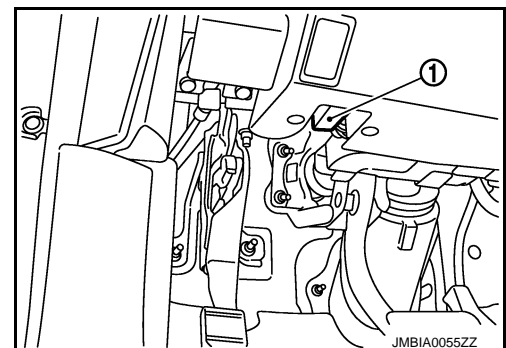

ON BOARD DIAGNOSTIC (OBD) SYSTEM

[VQ37VHR]

< SYSTEM DESCRIPTION >

3. Turn ignition switch ON.
4. Enter the program according to instruction on the screen or in the operation manual.
(*: Regarding GST screens in this section, sample screens are shown.)

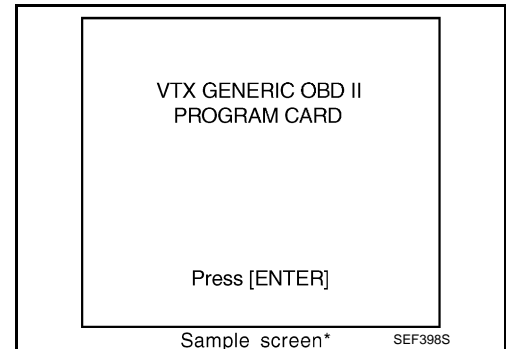

5. Perform each diagnostic mode according to each service procedure.
For further information, see the GST Operation Manual of the tool maker.

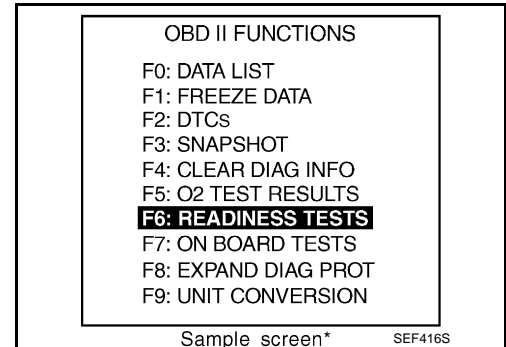

A

EC

C

D

E

F

G

H

I

J

K

L

M

N

O

P

DTC/CIRCUIT DIAGNOSIS

TROUBLE DIAGNOSIS - SPECIFICATION VALUE

Description

INFOID:000000005151682

The specification (SP) value indicates the tolerance of the value that is displayed in "SPEC" in "DATA MONITOR" mode of CONSULT-III during normal operation of the Engine Control System. When the value in "SPEC" in "DATA MONITOR" mode is within the SP value, the Engine Control System is confirmed OK. When the value in "SPEC" in "DATA MONITOR" mode is NOT within the SP value, the Engine Control System may have one or more malfunctions.

The SP value is used to detect malfunctions that may affect the Engine Control System, but will not illuminate the MIL.

The SP value will be displayed for the following three items:

- B/FUEL SCHDL (The fuel injection pulse width programmed into ECM prior to any learned on board correction)
- A/F ALPHA-B1/B2 (The mean value of air-fuel ratio feedback correction factor per cycle)
- MAS A/F SE-B1/B2 (The signal voltage of the mass air flow sensor)

Component Function Check

INFOID:000000005151683

1. PRECONDITIONING

Make sure that all of the following conditions are satisfied.

TESTING CONDITION

- Vehicle driven distance: More than 5,000 km (3,107 miles)
- Barometric pressure: 98.3 - 104.3 kPa (1.003 - 1.064 kg/cm², 14.25 - 15.12 psi)
- Atmospheric temperature: 20 - 30°C (68 - 86°F)
- Engine coolant temperature: 75 - 95°C (167 - 203°F)
- Transmission: Warmed-up
 - For A/T models: After the engine is warmed up to normal operating temperature, drive vehicle until "ATF TEMP 1" (A/T fluid temperature sensor signal) indicates more than 60°C (140°F).
 - For M/T models: After the engine is warmed up to normal operating temperature, drive for 5 minutes.
- Electrical load: Not applied
 - Rear window defogger switch, air conditioner switch, lighting switch are OFF. Steering wheel is straight ahead.
- Engine speed: Idle

>> GO TO 2.

2. PERFORM SPEC IN DATA MONITOR MODE

Ⓢ With CONSULT-III

NOTE:

Perform "SPEC" in "DATA MONITOR" mode in maximum scale display.

1. Perform [EC-13. "BASIC INSPECTION : Special Repair Requirement"](#).
2. Select "B/FUEL SCHDL", "A/F ALPHA-B1", "A/F ALPHA-B2", "MAS A/F SE-B1" and "MAS A/F SE-B2" in "SPEC" of "DATA MONITOR" mode with CONSULT-III.
3. Make sure that monitor items are within the SP value.

Is the measurement value within the SP value?

- YES >> INSPECTION END
 NO >> Go to [EC-133. "Diagnosis Procedure"](#).

TROUBLE DIAGNOSIS - SPECIFICATION VALUE

< DTC/CIRCUIT DIAGNOSIS >

[VQ37VHR]

Diagnosis Procedure

INFOID:000000005151684

OVERALL SEQUENCE

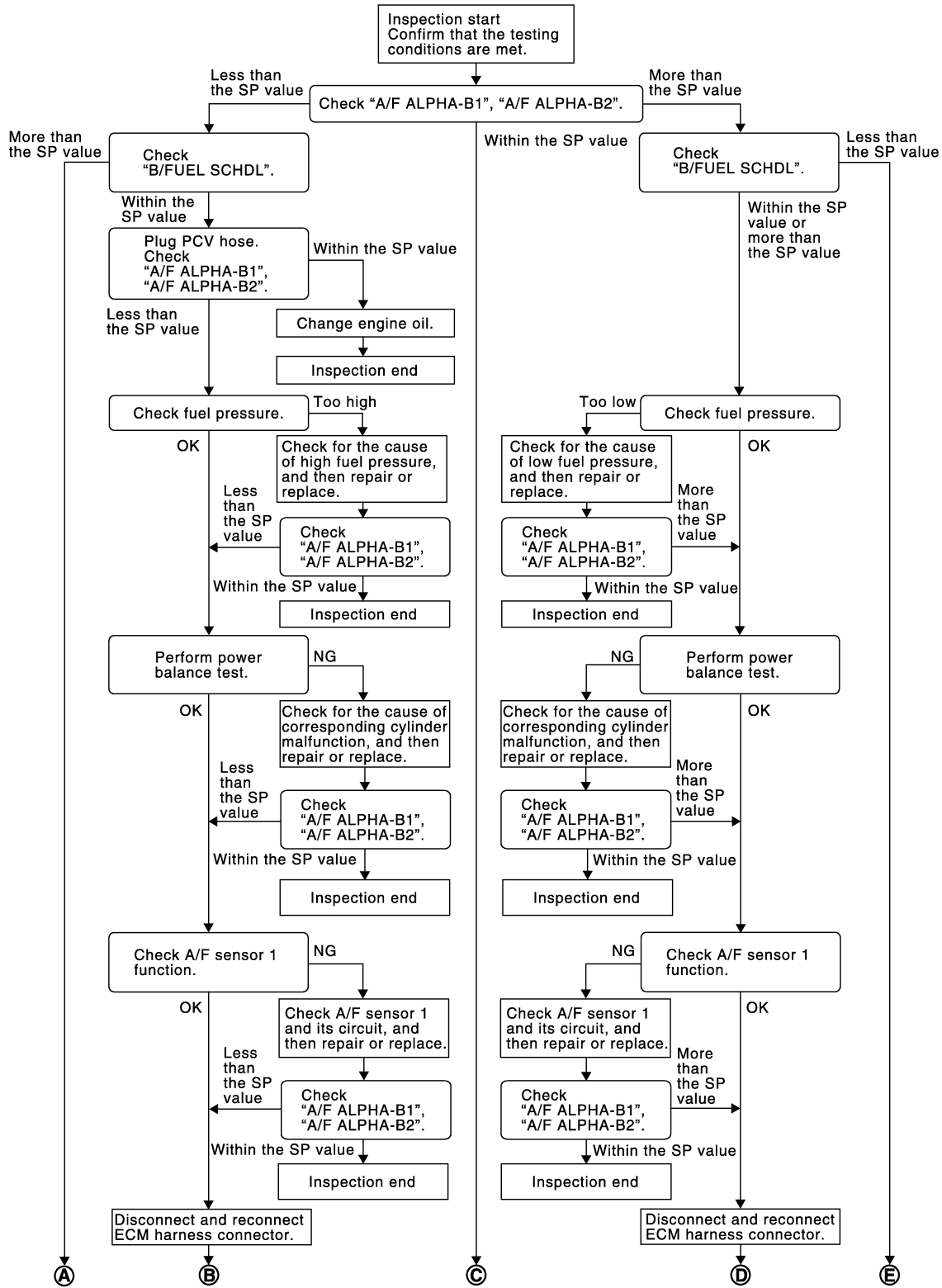

JMBIA1468GB

TROUBLE DIAGNOSIS - SPECIFICATION VALUE

< DTC/CIRCUIT DIAGNOSIS >

[VQ37VHR]

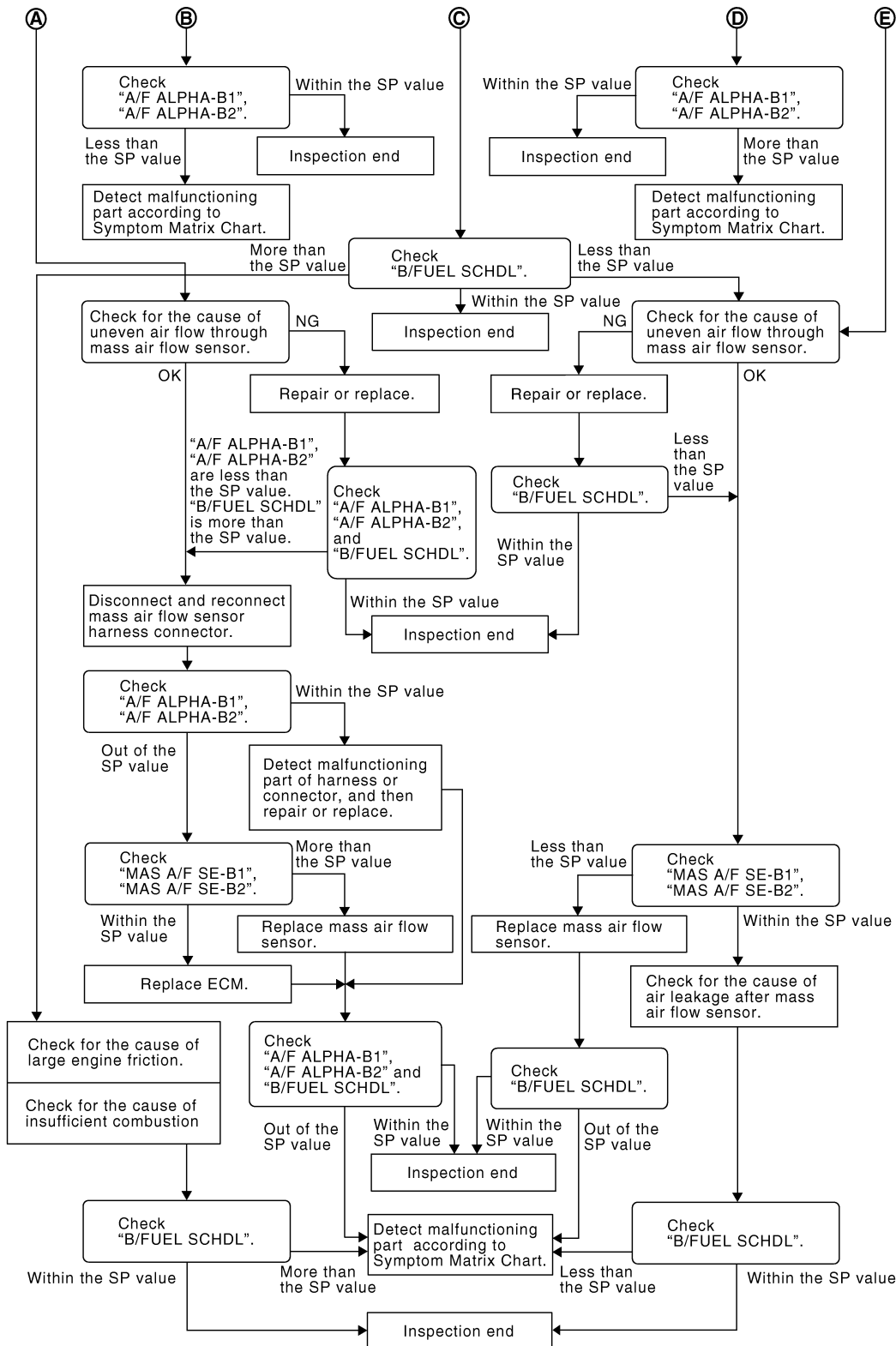

JMBIA0056GB

DETAILED PROCEDURE

1. CHECK "A/F ALPHA-B1", "A/F ALPHA-B2"

ⓑ With CONSULT-III

1. Start engine.
2. Confirm that the testing conditions are met. Refer to [EC-132, "Component Function Check"](#).
3. Select "A/F ALPHA-B1", "A/F ALPHA-B2" in "SPEC" of "DATA MONITOR" mode, and make sure that each indication is within the SP value.

TROUBLE DIAGNOSIS - SPECIFICATION VALUE

[VQ37VHR]

< DTC/CIRCUIT DIAGNOSIS >

NOTE:

Check "A/F ALPHA-B1", "A/F ALPHA-B2" for approximately 1 minute because they may fluctuate. It is NG if the indication is out of the SP value even a little.

Is the measurement value within the SP value?

YES >> GO TO 17.

NO-1 >> Less than the SP value: GO TO 2.

NO-2 >> More than the SP value: GO TO 3.

2.CHECK "B/FUEL SCHDL"

Select "B/FUEL SCHDL" in "SPEC" of "DATA MONITOR" mode, and make sure that the indication is within the SP value.

Is the measurement value within the SP value?

YES >> GO TO 4.

NO >> More than the SP value: GO TO 19.

3.CHECK "B/FUEL SCHDL"

Select "B/FUEL SCHDL" in "SPEC" of "DATA MONITOR" mode, and make sure that the indication is within the SP value.

Is the measurement value within the SP value?

YES >> GO TO 6.

NO-1 >> More than the SP value: GO TO 6.

NO-2 >> Less than the SP value: GO TO 25.

4.CHECK "A/F ALPHA-B1", "A/F ALPHA-B2"

1. Stop the engine.

2. Disconnect PCV hose, and then plug it.

3. Start engine.

4. Select "A/F ALPHA-B1", "A/F ALPHA-B2" in "SPEC" of "DATA MONITOR" mode, and make sure that each indication is within the SP value.

Is the measurement value within the SP value?

YES >> GO TO 5.

NO >> GO TO 6.

5.CHANGE ENGINE OIL

1. Stop the engine.

2. Change engine oil.

NOTE:

This symptom may occur when a large amount of gasoline is mixed with engine oil because of driving conditions (such as when engine oil temperature does not rise enough since a journey distance is too short during winter). The symptom will not be detected after changing engine oil or changing driving conditions.

>> INSPECTION END

6.CHECK FUEL PRESSURE

Check fuel pressure. (Refer to [EC-607, "Inspection".](#))

Is the inspection result normal?

YES >> GO TO 9.

NO-1 >> Fuel pressure is too high: Replace "fuel filter and fuel pump assembly" and then GO TO 8.

NO-2 >> Fuel pressure is too low: GO TO 7.

7.DETECT MALFUNCTIONING PART

Check fuel hoses and fuel tubes for clogging.

Is the inspection result normal?

YES >> Replace "fuel filter and fuel pump assembly" and then GO TO 8.

NO >> Repair or replace and then GO TO 8.

8.CHECK "A/F ALPHA-B1", "A/F ALPHA-B2"

TROUBLE DIAGNOSIS - SPECIFICATION VALUE

[VQ37VHR]

< DTC/CIRCUIT DIAGNOSIS >

1. Start engine.
2. Select "A/F ALPHA-B1", "A/F ALPHA-B2" in "SPEC" of "DATA MONITOR" mode, and make sure that each indication is within the SP value.

Is the measurement value within the SP value?

- YES >> INSPECTION END
NO >> GO TO 9.

9.PERFORM POWER BALANCE TEST

1. Perform "POWER BALANCE" in "ACTIVE TEST" mode.
2. Make sure that the each cylinder produces a momentary engine speed drop.

Is the inspection result normal?

- YES >> GO TO 12.
NO >> GO TO 10.

10.DETECT MALFUNCTIONING PART

Check the following bellow.

- Ignition coil and its circuit (Refer to [EC-503, "Component Function Check".](#))
- Fuel injector and its circuit (Refer to [EC-492, "Component Function Check".](#))
- Intake air leakage
- Low compression pressure (Refer to [EM-23, "Inspection".](#))

Is the inspection result normal?

- YES >> Replace fuel injector and then GO TO 11.
NO >> Repair or replace malfunctioning part and then GO TO 11.

11.CHECK "A/F ALPHA-B1", "A/F ALPHA-B2"

1. Start engine.
2. Select "A/F ALPHA-B1", "A/F ALPHA-B2" in "SPEC" of "DATA MONITOR" mode, and make sure that each indication is within the SP value.

Is the measurement value within the SP value?

- YES >> INSPECTION END
NO >> GO TO 12.

12.CHECK A/F SENSOR 1 FUNCTION

Perform all DTC CONFIRMATION PROCEDURE related with A/F sensor 1.

- For DTC P0130, P0150, refer to [EC-201, "DTC Logic".](#)
- For DTC P0131, P0151, refer to [EC-205, "DTC Logic".](#)
- For DTC P0132, P0152, refer to [EC-208, "DTC Logic".](#)
- For DTC P0133, P0153, refer to [EC-211, "DTC Logic".](#)
- For DTC P2A00, P2A03, refer to [EC-476, "DTC Logic".](#)

Are any DTCs detected?

- YES >> GO TO 13.
NO >> GO TO 15.

13.CHECK A/F SENSOR 1 CIRCUIT

Perform Diagnosis Procedure according to corresponding DTC.

>> GO TO 14.

14.CHECK "A/F ALPHA-B1", "A/F ALPHA-B2"

1. Start engine.
2. Select "A/F ALPHA-B1", "A/F ALPHA-B2" in "SPEC" of "DATA MONITOR" mode, and make sure that each indication is within the SP value.

Is the measurement value within the SP value?

- YES >> INSPECTION END
NO >> GO TO 15.

15.DISCONNECT AND RECONNECT ECM HARNESS CONNECTOR

1. Stop the engine.

TROUBLE DIAGNOSIS - SPECIFICATION VALUE

[VQ37VHR]

< DTC/CIRCUIT DIAGNOSIS >

2. Disconnect ECM harness connector. Check pin terminal and connector for damage, and then reconnect it.

>> GO TO 16.

16.CHECK "A/F ALPHA-B1", "A/F ALPHA-B2"

1. Start engine.
2. Select "A/F ALPHA-B1", "A/F ALPHA-B2" in "SPEC" of "DATA MONITOR" mode, and make sure that each indication is within the SP value.

Is the measurement value within the SP value?

YES >> INSPECTION END

NO >> Detect malfunctioning part according to [EC-595. "Symptom Table"](#).

17.CHECK "B/FUEL SCHDL"

Select "B/FUEL SCHDL" in "SPEC" of "DATA MONITOR" mode, and make sure that the indication is within the SP value.

Is the measurement value within the SP value?

YES >> INSPECTION END

NO-1 >> More than the SP value: GO TO 18.

NO-2 >> Less than the SP value: GO TO 25.

18.DETECT MALFUNCTIONING PART

1. Check for the cause of large engine friction. Refer to the following.
 - Engine oil level is too high
 - Engine oil viscosity
 - Belt tension of power steering, alternator, A/C compressor, etc. is excessive
 - Noise from engine
 - Noise from transmission, etc.
2. Check for the cause of insufficient combustion. Refer to the following.
 - Valve clearance malfunction
 - Intake valve timing control function malfunction
 - Camshaft sprocket installation malfunction, etc.

>> Repair or replace malfunctioning part, and then GO TO 30.

19.CHECK INTAKE SYSTEM

Check for the cause of uneven air flow through mass air flow sensor. Refer to the following.

- Crushed air ducts
- Malfunctioning seal of air cleaner element
- Uneven dirt of air cleaner element
- Improper specification of intake air system

Is the inspection result normal?

YES >> GO TO 21.

NO >> Repair or replace malfunctioning part, and then GO TO 20.

20.CHECK "A/F ALPHA-B1", "A/F ALPHA-B2", AND "B/FUEL SCHDL"

Select "A/F ALPHA-B1", "A/F ALPHA-B2", and "B/FUEL SCHDL" in "SPEC" of "DATA MONITOR" mode, and make sure that each indication is within the SP value.

Is the measurement value within the SP value?

YES >> INSPECTION END

NO >> "B/FUEL SCHDL" is more, "A/F ALPHA-B1", "A/F ALPHA-B2" are less than the SP value: GO TO 21.

21.DISCONNECT AND RECONNECT MASS AIR FLOW SENSOR HARNESS CONNECTOR

1. Stop the engine.
2. Disconnect mass air flow sensor harness connector. Check pin terminal and connector for damage and then reconnect it again.

>> GO TO 22.

TROUBLE DIAGNOSIS - SPECIFICATION VALUE

[VQ37VHR]

< DTC/CIRCUIT DIAGNOSIS >

22.CHECK "A/F ALPHA-B1", "A/F ALPHA-B2"

1. Start engine.
2. Select "A/F ALPHA-B1", "A/F ALPHA-B2" in "SPEC" of "DATA MONITOR" mode, and make sure that each indication is within the SP value.

Is the measurement value within the SP value?

YES >> Detect malfunctioning part of mass air flow sensor circuit and repair it. Refer to [EC-173, "Diagnosis Procedure"](#). Then GO TO 29.

NO >> GO TO 23.

23.CHECK "MAS A/F SE-B1", "MAS A/F SE-B2"

Select "MAS A/F SE-B1", "MAS A/F SE-B2" in "SPEC" of "DATA MONITOR" mode, and make sure that the indication is within the SP value.

Is the measurement value within the SP value?

YES >> GO TO 24.

NO >> More than the SP value: Replace malfunctioning mass air flow sensor, and then GO TO 29.

24.REPLACE ECM

1. Replace ECM.
2. Go to [EC-16, "ADDITIONAL SERVICE WHEN REPLACING CONTROL UNIT \(ECM\) : Special Repair Requirement"](#).

>> GO TO 29.

25.CHECK INTAKE SYSTEM

Check for the cause of uneven air flow through mass air flow sensor. Refer to the following.

- Crushed air ducts
- Malfunctioning seal in air cleaner element
- Uneven dirt in air cleaner element
- Improper specification in intake air system

Is the inspection result normal?

YES >> GO TO 27.

NO >> Repair or replace malfunctioning part, and then GO TO 26.

26.CHECK "B/FUEL SCHDL"

Select "B/FUEL SCHDL" in "SPEC" of "DATA MONITOR" mode, and make sure that the indication is within the SP value.

Is the measurement value within the SP value?

YES >> INSPECTION END

NO >> Less than the SP value: GO TO 27.

27.CHECK "MAS A/F SE-B1", "MAS A/F SE-B2"

Select "MAS A/F SE-B1", "MAS A/F SE-B2" in "SPEC" of "DATA MONITOR" mode, and make sure that each indication is within the SP value.

Is the measurement value within the SP value?

YES >> GO TO 28.

NO >> Less than the SP value: Replace malfunctioning mass air flow sensor, and then GO TO 30.

28.CHECK INTAKE SYSTEM

Check for the cause of air leak after the mass air flow sensor. Refer to the following.

- Disconnection, looseness, and cracks in air duct
- Looseness of oil filler cap
- Disconnection of oil level gauge
- Open stuck, breakage, hose disconnection, or cracks in PCV valve
- Disconnection or cracks in EVAP purge hose, stuck open EVAP canister purge volume control solenoid valve
- Malfunctioning seal in rocker cover gasket
- Disconnection, looseness, or cracks in hoses, such as a vacuum hose, connecting to intake air system parts

TROUBLE DIAGNOSIS - SPECIFICATION VALUE

< DTC/CIRCUIT DIAGNOSIS >

[VQ37VHR]

- Malfunctioning seal in intake air system, etc.

A

>> GO TO 30.

29.CHECK "A/F ALPHA-B1", "A/F ALPHA-B2", AND "B/FUEL SCHDL"

EC

Select "A/F ALPHA-B1", "A/F ALPHA-B2", and "B/FUEL SCHDL" in "SPEC" of "DATA MONITOR" mode, and make sure that each indication is within the SP value.

Is the measurement value within the SP value?

C

YES >> INSPECTION END

NO >> Detect malfunctioning part according to [EC-595. "Symptom Table"](#).

30.CHECK "B/FUEL SCHDL"

D

Select "B/FUEL SCHDL" in "SPEC" of "DATA MONITOR" mode, and then make sure that the indication is within the SP value.

Is the measurement value within the SP value?

E

YES >> INSPECTION END

NO >> Detect malfunctioning part according to [EC-595. "Symptom Table"](#).

F

G

H

I

J

K

L

M

N

O

P

POWER SUPPLY AND GROUND CIRCUIT

[VQ37VHR]

< DTC/CIRCUIT DIAGNOSIS >

POWER SUPPLY AND GROUND CIRCUIT

Diagnosis Procedure

INFOID:000000005151685

1. CHECK GROUND CONNECTION

1. Turn ignition switch OFF.
2. Check ground connection M95. Refer to Ground Inspection in [GI-39, "Circuit Inspection"](#).

Is the inspection result normal?

- YES >> GO TO 2.
NO >> Repair or replace ground connection.

2. CHECK ECM GROUND CIRCUIT FOR OPEN AND SHORT

1. Disconnect ECM harness connector.
2. Check the continuity between ECM harness connector.

ECM		Ground	Continuity
Connector	Terminal		
F101	8	Ground	Existed
M107	123		
	124		
	127		
	128		

3. Also check harness for short to power.

Is the inspection result normal?

- YES >> GO TO 4.
NO >> GO TO 3.

3. DETECT MALFUNCTIONING PART

Check the following.

- Harness connectors F103, M116
- Harness for open or short between ECM and ground

>> Repair open circuit or short to power in harness or connectors.

4. CHECK ECM POWER SUPPLY CIRCUIT-I

1. Reconnect ECM harness connector.
2. Turn ignition switch ON.
3. Check the voltage between ECM harness connector and ground.

ECM				Voltage
+		-		
Connector	Terminal	Connector	Terminal	
F102	53	M107	128	Battery voltage

Is the inspection result normal?

- YES >> GO TO 6.
NO >> GO TO 5.

5. DETECT MALFUNCTIONING PART

Check the following.

- Harness connectors E3, F1
- IPDM E/R harness connector E7
- 10 A fuse (No. 44)
- Harness for open or short between ECM and fuse

POWER SUPPLY AND GROUND CIRCUIT

< DTC/CIRCUIT DIAGNOSIS >

[VQ37VHR]

>> Repair open circuit, short to ground or short to power in harness or connectors.

6. CHECK ECM POWER SUPPLY CIRCUIT-II

1. Turn ignition switch OFF and wait at least 10 seconds.
2. Check the voltage between ECM harness connector terminals as follows.

ECM			Voltage
Connector	+	-	
	Terminal	Terminal	
M107	125	128	After turning ignition switch OFF, battery voltage will exist for a few seconds, then dropto approximately 0 V.

Is the inspection result normal?

- YES >> GO TO 7.
NO >> GO TO 9.

7. CHECK ECM POWER SUPPLY CIRCUIT-III

1. Turn ignition switch ON.
2. Check the voltage between IPDM E/R harness connector and ground.

IPDM E/R		Ground	Voltage
Connector	Terminal		
E7	53	Ground	Battery voltage

Is the inspection result normal?

- YES >> GO TO 8.
NO >> Replace IPDM E/R.

8. CHECK INTERMITTENT INCIDENT

Refer to [GI-36, "Intermittent Incident"](#).

>> INSPECTION END

9. CHECK ECM POWER SUPPLY CIRCUIT-IV

1. Turn ignition switch OFF and wait at least 10 seconds.
2. Check the voltage between ECM harness connector terminals.

ECM				Voltage
+		-		
Connector	Terminal	Connector	Terminal	
F101	24	M107	128	Battery voltage

Is the inspection result normal?

- YES >> GO TO 13.
NO >> GO TO 10.

10. CHECK ECM POWER SUPPLY CIRCUIT-V

1. Disconnect ECM harness connector.
2. Disconnect IPDM E/R harness connector.
3. Check the continuity between ECM harness connector and IPDM E/R harness connector.

ECM		IPDM E/R		Continuity
Connector	Terminal	Connector	Terminal	
F101	24	E7	69	Existed

POWER SUPPLY AND GROUND CIRCUIT

[VQ37VHR]

< DTC/CIRCUIT DIAGNOSIS >

4. Also check harness for short to ground and short to power.

Is the inspection result normal?

- YES >> GO TO 12.
- NO >> GO TO 11.

11.DETECT MALFUNCTIONING PART

Check the following.

- Harness or connectors E3, F1
- Harness for open or short between ECM and IPDM E/R

>> Repair open circuit, short to ground or short to power in harness or connectors.

12.CHECK 15 A FUSE

1. Disconnect 15 A fuse (No. 50) from IPDM E/R.
2. Check 15 A fuse.

Is the inspection result normal?

- YES >> GO TO 15.
- NO >> Replace 15 A fuse.

13.CHECK ECM POWER SUPPLY CIRCUIT-VI

1. Disconnect ECM harness connector.
2. Disconnect IPDM E/R harness connector.
3. Check the continuity between ECM harness connector and IPDM E/R harness connector.

ECM		IPDM E/R		Continuity
Connector	Terminal	Connector	Terminal	
M107	125	E7	49	Existed

4. Also check harness for short to ground and short to power.

Is the inspection result normal?

- YES >> GO TO 15.
- NO >> GO TO 14.

14.DETECT MALFUNCTIONING PART

Check the following.

- Harness or connectors E106, M6
- Harness for open or short between ECM and IPDM E/R

>> Repair open circuit, short to ground or short to power in harness or connectors.

15.CHECK INTERMITTENT INCIDENT

Refer to [GI-36. "Intermittent Incident"](#).

Is the inspection result normal?

- YES >> Replace IPDM E/R.
- NO >> Repair open circuit, short to ground or short to power in harness or connectors.

POWER SUPPLY AND GROUND CIRCUIT (VVEL CONTROL MODULE)

< DTC/CIRCUIT DIAGNOSIS >

[VQ37VHR]

POWER SUPPLY AND GROUND CIRCUIT (VVEL CONTROL MODULE)

Diagnosis Procedure

INFOID:000000005156440

1. CHECK GROUND CONNECTION

1. Turn ignition switch OFF.
2. Check ground connections M95, E46. Refer to Ground Inspection in [GI-39, "Circuit Inspection"](#).

Is the inspection result normal?

- YES >> GO TO 2.
NO >> Repair or replace ground connection.

2. CHECK ECM GROUND CIRCUIT FOR OPEN AND SHORT

1. Disconnect VVEL control module harness connector.
2. Check the continuity between VVEL control module harness connector and ground.

VVEL control module		Ground	Continuity
Connector	Terminal		
E15	14	Ground	Existed

3. Also check harness for short to power.

Is the inspection result normal?

- YES >> GO TO 3.
NO >> Repair open circuit or short to power in harness connectors.

3. CHECK VVEL CONTROL MODULE POWER SUPPLY CIRCUIT-I

1. Reconnect VVEL control module harness connector.
2. Turn ignition switch ON.
3. Check the voltage between VVEL control module harness connector.

VVEL control module			Voltage
Connector	+	-	
	Terminal	Terminal	
E15	8	14	After turning ignition switch OFF, battery voltage will exist for a few seconds, then drop to approximately 0 V.

Is the inspection result normal?

- YES >> GO TO 4.
NO >> GO TO 5.

4. CHECK INTERMITTENT INCIDENT

Refer to [GI-36, "Intermittent Incident"](#).

Is the inspection result normal?

- YES >> Replace IPDM E/R.
NO >> Repair open circuit, short to ground or short to power in harness or connectors.

5. CHECK VVEL CONTROL MODULE POWER SUPPLY CIRCUIT-II

1. Turn ignition switch OFF and wait at least 10 seconds.
2. Check the voltage between ECM harness connector terminals.

ECM				Voltage
+		-		
Connector	Terminal	Connector	Terminal	
F101	24	M107	128	Battery voltage

Is the inspection result normal?

POWER SUPPLY AND GROUND CIRCUIT (VVEL CONTROL MODULE)

[VQ37VHR]

< DTC/CIRCUIT DIAGNOSIS >

- YES >> GO TO 9.
NO >> GO TO 6.

6.CHECK VVEL CONTROL MODULE POWER SUPPLY CIRCUIT-III

1. Disconnect ECM harness connector.
2. Disconnect IPDM E/R harness connector.
3. Check the continuity between ECM harness connector and IPDM E/R harness connector.

ECM		IPDM E/R		Continuity
Connector	Terminal	Connector	Terminal	
F101	24	E7	69	Existed

4. Also check harness for short to ground and short to power.

Is the inspection result normal?

- YES >> GO TO 8.
NO >> GO TO 7.

7.DETECT MALFUNCTIONING PART

Check the following.

- Harness or connectors E3, F1
- Harness for open or short between ECM and IPDM E/R

>> Repair open circuit, short to ground or short to power in harness or connectors.

8.CHECK 15 A FUSE

1. Disconnect 15 A fuse (No. 50) from IPDM E/R.
2. Check 15 A fuse.

Is the inspection result normal?

- YES >> GO TO 9.
NO >> Replace 15A fuse.

9.CHECK VVEL CONTROL MODULE POWER SUPPLY CIRCUIT-IV

1. Disconnect ECM harness connector.
2. Disconnect IPDM E/R harness connector.
3. Check the continuity between ECM harness connector and IPDM E/R harness connector.

ECM		IPDM E/R		Continuity
Connector	Terminal	Connector	Terminal	
M107	125	E7	49	Existed

4. Also check harness for short to ground and short to power.

Is the inspection result normal?

- YES >> GO TO 11.
NO >> GO TO 10.

10.DETECT MALFUNCTIONING PART

Check the following.

- Harness or connectors E106, M6
- Harness for open or short between ECM and IPDM E/R

>> Repair open circuit, short to ground or short to power in harness or connectors.

11.CHECK INTERMITTENT INCIDENT

Refer to [GI-36. "Intermittent Incident"](#).

Is the inspection result normal?

- YES >> Replace IPDM E/R.
NO >> Repair open circuit, short to ground or short to power in harness or connectors.

U0101 CAN COMM CIRCUIT

< DTC/CIRCUIT DIAGNOSIS >

[VQ37VHR]

U0101 CAN COMM CIRCUIT

Description

INFOID:000000005151686

CAN (Controller Area Network) is a serial communication line for real time application. It is an on-vehicle multiplex communication line with high data communication speed and excellent error detection ability. Many electronic control units are equipped onto a vehicle, and each control unit shares information and links with other control units during operation (not independent). In CAN communication, control units are connected with 2 communication lines (CAN H line, CAN L line) allowing a high rate of information transmission with less wiring. Each control unit transmits/receives data but selectively reads required data only.

DTC Logic

INFOID:000000005151687

DTC DETECTION LOGIC

DTC No.	Trouble diagnosis name	DTC detecting condition	Possible cause
U0101	Lost communication with TCM	When ECM is not transmitting or receiving CAN communication signal of OBD (emission related diagnosis) with TCM for 2 seconds or more.	<ul style="list-style-type: none">CAN communication line between TCM and ECM (CAN communication line is open or shorted)

DTC CONFIRMATION PROCEDURE

1. PERFORM DTC CONFIRMATION PROCEDURE

- Turn ignition switch ON and wait at least 3 seconds.
- Check DTC.

Is DTC detected?

- YES >> [EC-145, "Diagnosis Procedure"](#).
NO >> INSPECTION END

Diagnosis Procedure

INFOID:000000005151688

Go to [LAN-16, "Trouble Diagnosis Flow Chart"](#).

U0113, U1003 CAN COMM CIRCUIT

< DTC/CIRCUIT DIAGNOSIS >

[VQ37VHR]

U0113, U1003 CAN COMM CIRCUIT

Description

INFOID:000000005151689

CAN (Controller Area Network) is a serial communication line for real time application. It is an on-vehicle multiplex communication line with high data communication speed and excellent error detection ability. ECM and VVEL control module are connected with two communication lines (CAN H line and CAN L line) and transmit/receive data. ECM shares information and links with the VVEL control module during operation.

DTC Logic

INFOID:000000005151690

DTC DETECTION LOGIC

NOTE:

If DTC U0113 or U1003 is displayed with DTC P0607, first perform the trouble diagnosis for DTC P0607. Refer to [EC-363, "DTC Logic"](#).

DTC No.	Trouble diagnosis name	DTC detecting condition	Possible cause
U0113	Lost communication with VVEL control module	CAN communication signal other than OBD (emission related diagnosis) is not received between VVEL control module and ECM for 2 seconds or more.	<ul style="list-style-type: none">• Harness or connectors (VVEL CAN communication line is open or shorted)• ECM• VVEL control module
U1003			

DTC CONFIRMATION PROCEDURE

1. PRECONDITIONING

TESTING CONDITION:

Before performing the following procedure, confirm that battery voltage is more than 10 V at idle.

>> GO TO 2.

2. PERFORM DTC CONFIRMATION PROCEDURE

1. Turn ignition switch ON and wait at least 3 seconds.
2. Check DTC.

Is DTC detected?

- YES >> Go to [EC-146, "Diagnosis Procedure"](#).
NO >> INSPECTION END

Diagnosis Procedure

INFOID:000000005151691

1. CHECK VVEL CAN COMMUNICATION CIRCUIT

1. Turn ignition switch OFF.
2. Disconnect ECM harness connector.
3. Disconnect VVEL control module harness connector.
4. Check the continuity between ECM harness connector and VVEL control module harness connector.

ECM		VVEL control module		Continuity
Connector	Terminal	Connector	Terminal	
F102	54	E15	24	Existed
	55		11	

5. Also check harness for short to ground and power.

Is the inspection result normal?

- YES >> GO TO 3.
NO >> GO TO 2.

2. DETECT MALFUNCTIONING PART

Check the following.

U0113, U1003 CAN COMM CIRCUIT

[VQ37VHR]

< DTC/CIRCUIT DIAGNOSIS >

- Harness connector E3, F1
- Harness for open or short between ECM and VVEL control module

A

>> Repair open circuit, short to ground or short to power in harness or connectors.

3. CHECK INTERMITTENT INCIDENT

EC

Refer to [GI-36, "Intermittent Incident"](#).

Is the inspection result normal?

C

YES >> GO TO 4.

NO >> Repair or replace.

4. REPLACE VVEL CONTROL MODULE

D

1. Replace VVEL control module.
2. Go to [EC-17, "ADDITIONAL SERVICE WHEN REPLACING CONTROL UNIT \(VVEL CONTROL MODULE\) : Special Repair Requirement"](#).

E

>> GO TO 5.

5. PERFORM DTC CONFIRMATION PROCEDURE

F

1. Reconnect all harness connectors disconnected.
2. Turn ignition switch ON.
3. Erase DTC.
4. Perform DTC Confirmation Procedure.
See [EC-146, "DTC Logic"](#).
5. Check DTC.

G

H

Is the DTC U0113 or U1003 displayed again?

YES >> GO TO 6.

NO >> INSPECTION END

I

6. REPLACE ECM

1. Replace ECM.
2. Go to [EC-16, "ADDITIONAL SERVICE WHEN REPLACING CONTROL UNIT \(ECM\) : Special Repair Requirement"](#).

J

K

>> INSPECTION END

L

M

N

O

P

U0164 CAN COMM CIRCUIT

< DTC/CIRCUIT DIAGNOSIS >

[VQ37VHR]

U0164 CAN COMM CIRCUIT

Description

INFOID:000000005151692

CAN (Controller Area Network) is a serial communication line for real time application. It is an on-vehicle multiplex communication line with high data communication speed and excellent error detection ability. Many electronic control units are equipped onto a vehicle, and each control unit shares information and links with other control units during operation (not independent). In CAN communication, control units are connected with 2 communication lines (CAN H line, CAN L line) allowing a high rate of information transmission with less wiring. Each control unit transmits/receives data but selectively reads required data only.

DTC Logic

INFOID:000000005151693

DTC DETECTION LOGIC

DTC No.	Trouble diagnosis name	DTC detecting condition	Possible cause
U0164	Lost communication with Unified meter and A/C amp.	When ECM is not transmitting or receiving CAN communication signal of OBD (emission related diagnosis) with Unified meter and A/C amp. for 2 seconds or more.	<ul style="list-style-type: none">CAN communication line between Unified meter and A/C amp. and ECM (CAN communication line is open or shorted)

DTC CONFIRMATION PROCEDURE

1. PERFORM DTC CONFIRMATION PROCEDURE

- Turn ignition switch ON and wait at least 3 seconds.
- Check DTC.

Is DTC detected?

- YES >> [EC-148, "Diagnosis Procedure"](#).
NO >> INSPECTION END

Diagnosis Procedure

INFOID:000000005151694

Go to [LAN-16, "Trouble Diagnosis Flow Chart"](#).

U1001 CAN COMM CIRCUIT

< DTC/CIRCUIT DIAGNOSIS >

[VQ37VHR]

U1001 CAN COMM CIRCUIT

Description

INFOID:000000005151695

CAN (Controller Area Network) is a serial communication line for real time application. It is an on-vehicle multiplex communication line with high data communication speed and excellent error detection ability. Many electronic control units are equipped onto a vehicle, and each control unit shares information and links with other control units during operation (not independent). In CAN communication, control units are connected with 2 communication lines (CAN H line, CAN L line) allowing a high rate of information transmission with less wiring. Each control unit transmits/receives data but selectively reads required data only.

DTC Logic

INFOID:000000005151696

DTC DETECTION LOGIC

DTC No.	Trouble diagnosis name	DTC detecting condition	Possible cause
U1001	CAN communication line	When ECM is not transmitting or receiving CAN communication signal other than OBD (emission related diagnosis) for 2 seconds or more.	<ul style="list-style-type: none">Harness or connectors (CAN communication line is open or shorted)

DTC CONFIRMATION PROCEDURE

1. PERFORM DTC CONFIRMATION PROCEDURE

1. Turn ignition switch ON and wait at least 3 seconds.
2. Check DTC.

Is DTC detected?

- YES >> [EC-149, "Diagnosis Procedure"](#).
NO >> INSPECTION END

Diagnosis Procedure

INFOID:000000005151697

Go to [LAN-16, "Trouble Diagnosis Flow Chart"](#).

U1024 CAN COMM CIRCUIT

< DTC/CIRCUIT DIAGNOSIS >

[VQ37VHR]

U1024 CAN COMM CIRCUIT

Description

INFOID:000000005151698

CAN (Controller Area Network) is a serial communication line for real time application. It is an on-vehicle multiplex communication line with high data communication speed and excellent error detection ability. ECM and VVEL control module are connected with two communication lines (CAN H line and CAN L line) and transmit/receive data. ECM shares information and links with the VVEL control module during operation.

DTC Logic

INFOID:000000005151699

DTC DETECTION LOGIC

NOTE:

If DTC U1024 is displayed with DTC P0607, first perform the trouble diagnosis for DTC P0607. Refer to [EC-363, "DTC Logic"](#).

DTC No.	Trouble diagnosis name	DTC detecting condition	Possible cause
U1024	VVEL CAN communication	<ul style="list-style-type: none">When VVEL control module cannot transmit/receive can communication signal from ECM for 2 seconds or more.When detecting error during the initial diagnosis of CAN controller of VVEL control module.	<ul style="list-style-type: none">Harness or connectors (VELL CAN communication line is open or shorted)ECMVVEL control module

DTC CONFIRMATION PROCEDURE

1. PRECONDITIONING

TESTING CONDITION:

Before performing the following procedure, confirm that battery voltage is more than 10 V at idle.

>> GO TO 2.

2. PERFORM DTC CONFIRMATION PROCEDURE

- Turn ignition switch ON and wait at least 3 seconds.
- Check DTC.

Is DTC detected?

YES >> Go to [EC-150, "Diagnosis Procedure"](#).
NO >> INSPECTION END

Diagnosis Procedure

INFOID:000000005151700

1. CHECK VVEL CAN COMMUNICATION CIRCUIT

- Turn ignition switch OFF.
- Disconnect ECM harness connector.
- Disconnect VVEL control module harness connector.
- Check the continuity between ECM harness connector and VVEL control module harness connector.

ECM		VVEL control module		Continuity
Connector	Terminal	Connector	Terminal	
F102	54	E15	24	Existed
	55		11	

- Also check harness for short to ground and power.

Is the inspection result normal?

YES >> GO TO 3.
NO >> GO TO 2.

U1024 CAN COMM CIRCUIT

[VQ37VHR]

< DTC/CIRCUIT DIAGNOSIS >

2. DETECT MALFUNCTIONING PART

Check the following.

- Harness connector E3, F1
- Harness for open or short between ECM and VVEL control module

>> Harness for open, short to ground or short to power in harness or connectors.

3. CHECK INTERMITTENT INCIDENT

Refer to [GI-36, "Intermittent Incident"](#).

Is the inspection result normal?

- YES >> GO TO 4.
- NO >> Repair or replace.

4. REPLACE VVEL CONTROL MODULE

1. Replace VVEL control module.
2. Go to [EC-17, "ADDITIONAL SERVICE WHEN REPLACING CONTROL UNIT \(VVEL CONTROL MODULE\) : Special Repair Requirement"](#).

>> GO TO 5.

5. PERFORM DTC CONFIRMATION PROCEDURE

1. Reconnect all harness connectors disconnected.
2. Turn ignition switch ON.
3. Erase DTC.
4. Perform DTC Confirmation Procedure.
See [EC-150, "DTC Logic"](#).

Is the DTC U1024 displayed again?

- YES >> GO TO 6.
- NO >> INSPECTION END

6. REPLACE ECM

1. Replace ECM.
2. Go to [EC-16, "ADDITIONAL SERVICE WHEN REPLACING CONTROL UNIT \(ECM\) : Special Repair Requirement"](#).

>> INSPECTION END

A
EC
C
D
E
F
G
H
I
J
K
L
M
N
O
P

P0011, P0021 IVT CONTROL

< DTC/CIRCUIT DIAGNOSIS >

[VQ37VHR]

P0011, P0021 IVT CONTROL

DTC Logic

INFOID:000000005151701

DTC DETECTION LOGIC

NOTE:

- If DTC P0011 or P0021 is displayed with DTC P0075 or P0081, first perform the trouble diagnosis for DTC P0075, P0081. Refer to [EC-162, "DTC Logic"](#).
- If DTC P0011 or P0021 is displayed with DTC P0524, first perform the trouble diagnosis for DTC P0524. Refer to [EC-348, "DTC Logic"](#).

DTC No.	Trouble diagnosis name	Detecting condition	Possible cause
P0011	Intake valve timing control performance (bank 1)	There is a gap between angle of target and phase-control angle degree.	<ul style="list-style-type: none">• Crankshaft position sensor (POS)• Camshaft position sensor (PHASE)• Intake valve control solenoid valve• Accumulation of debris to the signal pick-up portion of the camshaft• Timing chain installation• Foreign matter caught in the oil groove for intake valve timing control
P0021	Intake valve timing control performance (bank 2)		

DTC CONFIRMATION PROCEDURE

1. PRECONDITIONING

If DTC Confirmation Procedure has been previously conducted, always perform the following procedure before conducting the next test.

1. Turn ignition switch OFF and wait at least 10 seconds.
2. Turn ignition switch ON.
3. Turn ignition switch OFF and wait at least 10 seconds.

TESTING CONDITION:

Before performing the following procedure, confirm that battery voltage is between 10 V and 16 V at idle.

>> GO TO 2.

2. PERFORM DTC CONFIRMATION PROCEDURE-I

1. Turn ignition switch ON and select "DATA MONITOR" mode with CONSULT-III.
2. Start engine and warm it up to the normal operating temperature.
3. Maintain the following conditions for at least 6 consecutive seconds. Hold the accelerator pedal as steady as possible.

VHCL SPEED SE	100 - 120 km/h (63 - 75 mph)
ENG SPEED	1,200 - 2,000 rpm
COOLAN TEMP/S	More than 60°C (140°F)
B/FUEL SCHDL	More than 7.3 msec
Selector lever	D position (A/T) 5th position (M/T)

CAUTION:

Always drive at a safe speed.

4. Stop vehicle with engine running and let engine idle for 10 seconds.
5. Check 1st trip DTC.

Is 1st trip DTC detected?

YES >> Go to [EC-153, "Diagnosis Procedure"](#)

NO >> GO TO 3.

3. PERFORM DTC CONFIRMATION PROCEDURE-II

P0011, P0021 IVT CONTROL

[VQ37VHR]

< DTC/CIRCUIT DIAGNOSIS >

1. Select "DATA MONITOR" mode with CONSULT-III.
2. Maintain the following conditions for at least 20 consecutive seconds.

ENG SPEED	1,700 - 3,175 rpm (A constant rotation is maintained.)
COOLAN TEMP/S	More than 70°C (158°F)
Selector lever	1st or 2nd position
Driving location	Driving vehicle uphill (Increased engine load will help maintain the driving conditions required for this test.)

CAUTION:

Always drive at a safe speed.

3. Check 1st trip DTC.

Is 1st trip DTC detected?

- YES >> Go to [EC-153. "Diagnosis Procedure"](#)
NO >> INSPECTION END

Diagnosis Procedure

INFOID:000000005151702

1. CHECK OIL PRESSURE WARNING LAMP

1. Start engine.
2. Check oil pressure warning lamp and confirm it is not illuminated.

Is oil pressure warning lamp illuminated?

- YES >> Go to [LU-6. "Inspection"](#).
NO >> GO TO 2.

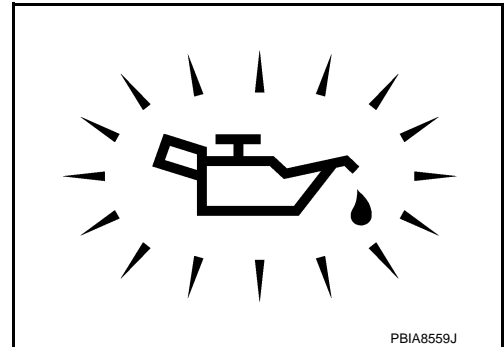

2. CHECK INTAKE VALVE TIMING CONTROL SOLENOID VALVE

Refer to [EC-154. "Component Inspection"](#).

Is the inspection result normal?

- YES >> GO TO 3.
NO >> Replace malfunctioning intake valve timing control solenoid valve.

3. CHECK CRANKSHAFT POSITION SENSOR (POS)

Refer to [EC-272. "Component Inspection"](#).

Is the inspection result normal?

- YES >> GO TO 4.
NO >> Replace crankshaft position sensor (POS).

4. CHECK CAMSHAFT POSITION SENSOR (PHASE)

Refer to [EC-275. "Component Inspection"](#).

Is the inspection result normal?

- YES >> GO TO 5.
NO >> Replace malfunctioning camshaft position sensor (PHASE).

5. CHECK CAMSHAFT (INTAKE)

Check the following.

P0011, P0021 IVT CONTROL

[VQ37VHR]

< DTC/CIRCUIT DIAGNOSIS >

- Accumulation of debris on the signal plate of camshaft front end
- Chipping signal plate of camshaft front end

Is the inspection result normal?

- YES >> GO TO 6.
NO >> Remove debris and clean the signal plate of camshaft front end or replace camshaft.

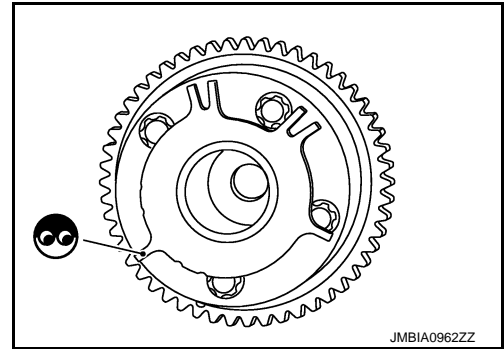

6. CHECK TIMING CHAIN INSTALLATION

Check service records for any recent repairs that may cause timing chain misaligned.

Are there any service records that may cause timing chain misaligned?

- YES >> Check timing chain installation. Refer to [EM-50, "Removal and Installation"](#).
NO >> GO TO 7.

7. CHECK LUBRICATION CIRCUIT

Perform "Inspection of Camshaft Sprocket (INT) Oil Groove". Refer to [LU-6, "Inspection"](#).

Is the inspection result normal?

- YES >> GO TO 8.
NO >> Clean lubrication line.

8. CHECK INTERMITTENT INCIDENT

Refer to [GI-36, "Intermittent Incident"](#).

>> INSPECTION END

Component Inspection

INFOID:000000005151703

1. CHECK INTAKE VALVE TIMING CONTROL SOLENOID VALVE-I

1. Turn ignition switch OFF.
2. Disconnect intake valve timing control solenoid valve harness connector.
3. Check resistance between intake valve timing control solenoid valve terminals as follows.

Terminals	Resistance (Ω)
1 and 2	7.0 - 7.7 [at 20°C (68°F)]
1 or 2 and ground	∞ (Continuity should not exist)

Is the inspection result normal?

- YES >> GO TO 2.
NO >> Replace malfunctioning intake valve timing control solenoid valve.

2. CHECK INTAKE VALVE TIMING CONTROL SOLENOID VALVE-II

1. Remove intake valve timing control solenoid valve.
2. Provide 12 V DC between intake valve timing control solenoid valve terminals 1 and 2, and then interrupt it. Make sure that the plunger moves as shown in the figure.

CAUTION:

Do not apply 12 V DC continuously for 5 seconds or more. Doing so may result in damage to the coil in intake valve timing control solenoid valve.

NOTE:

Always replace O-ring when intake valve timing control solenoid valve is removed.

Is the inspection result normal?

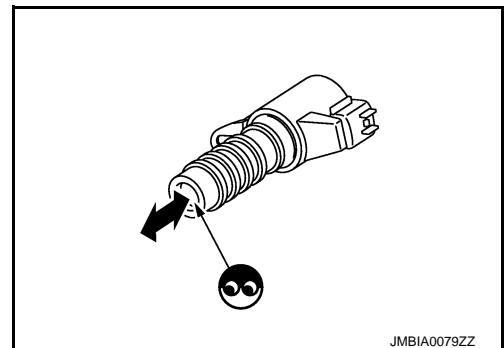

P0011, P0021 IVT CONTROL

< DTC/CIRCUIT DIAGNOSIS >

[VQ37VHR]

YES >> INSPECTION END
NO >> Replace malfunctioning intake valve timing control solenoid valve.

A

EC

C

D

E

F

G

H

I

J

K

L

M

N

O

P

P0031, P0032, P0051, P0052 A/F SENSOR 1 HEATER

< DTC/CIRCUIT DIAGNOSIS >

[VQ37VHR]

P0031, P0032, P0051, P0052 A/F SENSOR 1 HEATER

Description

INFOID:000000005151704

SYSTEM DESCRIPTION

Sensor	Input Signal to ECM	ECM function	Actuator
Camshaft position sensor (PHASE) Crankshaft position sensor (POS)	Engine speed	Air fuel ratio (A/F) sensor 1 heater control	Air fuel ratio (A/F) sensor 1 heater
Mass air flow sensor	Amount of intake air		

The ECM performs ON/OFF duty control of the A/F sensor 1 heater corresponding to the engine operating condition to keep the temperature of A/F sensor 1 element at the specified range.

DTC Logic

INFOID:000000005151705

DTC DETECTION LOGIC

DTC No.	Trouble diagnosis name	DTC detecting condition	Possible cause
P0031	Air fuel ratio (A/F) sensor 1 heater (bank 1) control circuit low	The current amperage in the A/F sensor 1 heater circuit is out of the normal range. (An excessively low voltage signal is sent to ECM through the A/F sensor 1 heater.)	<ul style="list-style-type: none">• Harness or connectors (The A/F sensor 1 heater circuit is open or shorted.)• A/F sensor 1 heater
P0032	Air fuel ratio (A/F) sensor 1 heater (bank 1) control circuit high	The current amperage in the A/F sensor 1 heater circuit is out of the normal range. (An excessively high voltage signal is sent to ECM through the A/F sensor 1 heater.)	<ul style="list-style-type: none">• Harness or connectors (The A/F sensor 1 heater circuit is shorted.)• A/F sensor 1 heater
P0051	Air fuel ratio (A/F) sensor 1 heater (bank 2) control circuit low	The current amperage in the A/F sensor 1 heater circuit is out of the normal range. (An excessively low voltage signal is sent to ECM through the A/F sensor 1 heater.)	<ul style="list-style-type: none">• Harness or connectors (The A/F sensor 1 heater circuit is open or shorted.)• A/F sensor 1 heater
P0052	Air fuel ratio (A/F) sensor 1 heater (bank 2) control circuit high	The current amperage in the A/F sensor 1 heater circuit is out of the normal range. (An excessively high voltage signal is sent to ECM through the A/F sensor 1 heater.)	<ul style="list-style-type: none">• Harness or connectors (The A/F sensor 1 heater circuit is shorted.)• A/F sensor 1 heater

DTC CONFIRMATION PROCEDURE

1. PRECONDITIONING

If DTC Confirmation Procedure has been previously conducted, always perform the following procedure before conducting the next test.

1. Turn ignition switch OFF and wait at least 10 seconds.
2. Turn ignition switch ON.
3. Turn ignition switch OFF and wait at least 10 seconds.

TESTING CONDITION:

Before performing the following procedure, confirm that battery voltage is between 10.5 V and 16 V at idle.

>> GO TO 2.

2. PERFORM DTC CONFIRMATION PROCEDURE

1. Start engine and let it idle for at least 10 seconds.
2. Check 1st trip DTC.

Is 1st trip DTC detected?

- YES >> Go to [EC-157, "Diagnosis Procedure"](#).
NG >> INSPECTION END

P0031, P0032, P0051, P0052 A/F SENSOR 1 HEATER

< DTC/CIRCUIT DIAGNOSIS >

[VQ37VHR]

Diagnosis Procedure

INFOID:000000005151706

1. CHECK GROUND CONNECTION

1. Turn ignition switch OFF.
2. Check ground connection M95. Refer to Ground Inspection in [GI-39. "Circuit Inspection"](#).

Is the inspection result normal?

- YES >> GO TO 2.
NO >> Repair or replace ground connection.

2. CHECK AIR FUEL RATIO (A/F) SENSOR 1 POWER SUPPLY CIRCUIT

1. Disconnect air fuel ratio (A/F) sensor 1 harness connector.
2. Turn ignition switch ON.
3. Check the voltage between A/F sensor 1 harness connector and ground.

DTC	A/F sensor 1			Ground	Voltage
	Bank	Connector	Terminal		
P0031, P0032	1	F3	4	Ground	Battery voltage
P0051, P0052	2	F20	4		

Is the inspection result normal?

- YES >> GO TO 4.
NO >> GO TO 3.

3. DETECT MALFUNCTIONING PART

Check the following.

- Harness connectors E3, F1
- IPDM E/R harness connector E7
- 15 A fuse (No. 46)
- Harness for open or short between A/F sensor 1 and fuse

>> Repair or replace harness or connectors.

4. CHECK A/F SENSOR 1 HEATER OUTPUT SIGNAL CIRCUIT

1. Turn ignition switch OFF.
2. Disconnect ECM harness connector.
3. Check the continuity between A/F sensor 1 harness connector and ECM harness connector.

DTC	A/F sensor 1			ECM		Continuity
	Bank	Connector	Terminal	Connector	Terminal	
P0031, P0032	1	F3	3	F101	1	Existed
P0051, P0052	2	F20	3		5	

4. Also check harness for short to ground and short to power.

Is the inspection result normal?

- YES >> GO TO 5.
NO >> Repair open circuit, short to ground or short to power in harness or connectors.

5. CHECK A/F SENSOR 1 HEATER

Refer to [EC-158. "Component Inspection"](#).

Is the inspection result normal?

- YES >> GO TO 7.
NO >> GO TO 6.

6. REPLACE AIR FUEL RATIO (A/F) SENSOR 1

Replace malfunctioning air fuel ratio (A/F) sensor 1.

CAUTION:

P0031, P0032, P0051, P0052 A/F SENSOR 1 HEATER

[VQ37VHR]

< DTC/CIRCUIT DIAGNOSIS >

- Discard any A/F sensor which has been dropped from a height of more than 0.5 m (19.7 in) onto a hard surface such as a concrete floor; use a new one.
- Before installing new A/F sensor, clean exhaust system threads using Oxygen Sensor Thread Cleaner [commercial service tool (J-43897-18 or J-43897-12)] and approved Anti-seize Lubricant (commercial service tool).

>> INSPECTION END

7. CHECK INTERMITTENT INCIDENT

Perform [GI-36, "Intermittent Incident"](#).

>> Repair or replace.

Component Inspection

INFOID:000000005151707

1. CHECK AIR FUEL RATIO (A/F) SENSOR 1

1. Turn ignition switch OFF.
2. Disconnect A/F sensor 1 harness connector.
3. Check resistance between A/F sensor 1 terminals as follows.

Terminal	Resistance (Ω)
3 and 4	1.8 - 2.44 [at 25°C (77°F)]
3 and 1, 2	∞
4 and 1, 2	(Continuity should not exist)

Is the inspection result normal?

YES >> INSPECTION END

NO >> GO TO 2.

2. REPLACE AIR FUEL RATIO (A/F) SENSOR 1

Replace malfunctioning air fuel ratio (A/F) sensor 1.

CAUTION:

- Discard any A/F sensor which has been dropped from a height of more than 0.5 m (19.7 in) onto a hard surface such as a concrete floor; use a new one.
- Before installing new A/F sensor, clean exhaust system threads using Oxygen Sensor Thread Cleaner [commercial service tool (J-43897-18 or J-43897-12)] and approved Anti-seize Lubricant (commercial service tool).

>> INSPECTION END

P0037, P0038, P0057, P0058 HO2S2 HEATER

< DTC/CIRCUIT DIAGNOSIS >

[VQ37VHR]

P0037, P0038, P0057, P0058 HO2S2 HEATER

Description

INFOID:000000005151708

SYSTEM DESCRIPTION

Sensor	Input signal to ECM	ECM function	Actuator
Camshaft position sensor (PHASE) Crankshaft position sensor (POS)	Engine speed	Heated oxygen sensor 2 heater control	Heated oxygen sensor 2 heater
Engine coolant temperature sensor	Engine coolant temperature		
Mass air flow sensor	Amount of intake air		

The ECM performs ON/OFF control of the heated oxygen sensor 2 heater corresponding to the engine speed, amount of intake air and engine coolant temperature.

OPERATION

Engine speed rpm	Heated oxygen sensor 2 heater
Above 3,600	OFF
Below 3,600 rpm after the following conditions are met. <ul style="list-style-type: none">• Engine: After warming up• Keeping the engine speed between 3,500 and 4,000 rpm for 1 minute and at idle for 1 minute under no load	ON

DTC Logic

INFOID:000000005151709

DTC DETECTION LOGIC

DTC No.	Trouble diagnosis name	DTC detecting condition	Possible cause
P0037	Heated oxygen sensor 2 heater (bank 1) control circuit low	The current amperage in the heated oxygen sensor 2 heater circuit is out of the normal range. (An excessively low voltage signal is sent to ECM through the heated oxygen sensor 2 heater.)	<ul style="list-style-type: none">• Harness or connectors (The heated oxygen sensor 2 heater circuit is open or shorted.)• Heated oxygen sensor 2 heater
P0038	Heated oxygen sensor 2 heater (bank 1) control circuit high	The current amperage in the heated oxygen sensor 2 heater circuit is out of the normal range. (An excessively high voltage signal is sent to ECM through the heated oxygen sensor 2 heater.)	<ul style="list-style-type: none">• Harness or connectors (The heated oxygen sensor 2 heater circuit is shorted.)• Heated oxygen sensor 2 heater
P0057	Heated oxygen sensor 2 heater (bank 2) control circuit low	The current amperage in the heated oxygen sensor 2 heater circuit is out of the normal range. (An excessively low voltage signal is sent to ECM through the heated oxygen sensor 2 heater.)	<ul style="list-style-type: none">• Harness or connectors (The heated oxygen sensor 2 heater circuit is open or shorted.)• Heated oxygen sensor 2 heater
P0058	Heated oxygen sensor 2 heater (bank 2) control circuit high	The current amperage in the heated oxygen sensor 2 heater circuit is out of the normal range. (An excessively high voltage signal is sent to ECM through the heated oxygen sensor 2 heater.)	<ul style="list-style-type: none">• Harness or connectors (The heated oxygen sensor 2 heater circuit is shorted.)• Heated oxygen sensor 2 heater

DTC CONFIRMATION PROCEDURE

1. PRECONDITIONING

If DTC Confirmation Procedure has been previously conducted, always perform the following procedure before conducting the next test.

1. Turn ignition switch OFF and wait at least 10 seconds.
2. Turn ignition switch ON.
3. Turn ignition switch OFF and wait at least 10 seconds.

TESTING CONDITION:

Before performing the following procedure, confirm that battery voltage is between 11 V and 16 V at idle.

>> GO TO 2.

P0037, P0038, P0057, P0058 HO2S2 HEATER

< DTC/CIRCUIT DIAGNOSIS >

[VQ37VHR]

2. PERFORM DTC CONFIRMATION PROCEDURE

1. Start engine and warm it up to the normal operating temperature.
2. Turn ignition switch OFF and wait at least 10 seconds.
3. Turn ignition switch ON.
4. Turn ignition switch OFF and wait at least 10 seconds.
5. Start engine and keep the engine speed between 3,500 and 4,000 rpm for at least 1 minute under no load.
6. Let engine idle for 1 minute.
7. Check 1st trip DTC.

Is 1st trip DTC detected?

- YES >> Go to [EC-160, "Diagnosis Procedure"](#).
NO >> INSPECTION END

Diagnosis Procedure

INFOID:000000005151710

1. CHECK GROUND CONNECTION

1. Turn ignition switch OFF.
2. Check ground connection M95. Refer to Ground Inspection in [GI-39, "Circuit Inspection"](#).

Is the inspection result normal?

- YES >> GO TO 2.
NO >> Repair or replace ground connection.

2. CHECK HO2S2 POWER SUPPLY CIRCUIT

1. Disconnect heated oxygen sensor 2 (HO2S2) harness connector.
2. Turn ignition switch ON.
3. Check the voltage between HO2S2 harness connector and ground.

DTC	HO2S2			Ground	Voltage
	Bank	Connector	Terminal		
P0037, P0038	1	F54	2	Ground	Battery voltage
P0057, P0058	2	F53	2		

Is the inspection result normal?

- YES >> GO TO 4.
NO >> GO TO 3.

3. DETECT MALFUNCTIONING PART

Check the following.

- Harness connectors E3, F1
- IPDM E/R harness connector E7
- 15 A fuse (No. 46)
- Harness for open or short between heated oxygen sensor 2 and fuse

>> Repair open circuit, short to ground or short to power in harness or connectors.

4. CHECK HO2S2 OUTPUT SIGNAL CIRCUIT FOR OPEN AND SHORT

1. Turn ignition switch OFF.
2. Disconnect ECM harness connector.
3. Check the continuity between HO2S2 harness connector and ECM harness connector.

DTC	HO2S2			ECM		Continuity
	Bank	Connector	Terminal	Connector	Terminal	
P0037, P0038	1	F54	3	F101	17	Existed
P0057, P0058	2	F53	3		33	

4. Also check harness for short to ground and short to power.

Is the inspection result normal?

P0037, P0038, P0057, P0058 HO2S2 HEATER

[VQ37VHR]

< DTC/CIRCUIT DIAGNOSIS >

- YES >> GO TO 5.
NO >> Repair open circuit, short to ground or short to power in harness or connectors.

5.CHECK HEATED OXYGEN SENSOR 2 HEATER

Refer to [EC-161, "Component Inspection"](#).

Is the inspection result normal?

- YES >> GO TO 7.
NO >> GO TO 6.

6.REPLACE HEATED OXYGEN SENSOR 2

Replace malfunctioning heated oxygen sensor 2.

CAUTION:

- Discard any heated oxygen sensor which has been dropped from a height of more than 0.5 m (19.7 in) onto a hard surface such as a concrete floor; use a new one.
- Before installing new heated oxygen sensor, clean exhaust system threads using Oxygen Sensor Thread Cleaner [commercial service tool (J-43897-18 or J-43897-12)] and approved Anti-seize Lubricant (commercial service tool).

>> INSPECTION END

7.CHECK INTERMITTENT INCIDENT

Refer to [GI-36, "Intermittent Incident"](#).

>> INSPECTION END

Component Inspection

INFOID:000000005151711

1.CHECK HEATED OXYGEN SENSOR 2 HEATER

1. Turn ignition switch OFF.
2. Disconnect heated oxygen sensor 2 harness connector.
3. Check resistance between HO2S2 terminals as follows.

Terminal	Resistance (Ω)
2 and 3	3.4 - 4.4 [at 25°C (77°F)]
1 and 2, 3, 4	∞
4 and 1, 2, 3	(Continuity should not exist)

Is the inspection result normal?

- YES >> INSPECTION END
NO >> GO TO 2.

2.REPLACE HEATED OXYGEN SENSOR 2

Replace malfunctioning heated oxygen sensor 2.

CAUTION:

- Discard any heated oxygen sensor which has been dropped from a height of more than 0.5 m (19.7 in) onto a hard surface such as a concrete floor; use a new one.
- Before installing new oxygen sensor, clean exhaust system threads using Oxygen Sensor Thread Cleaner [commercial service tool (J-43897-18 or J-43897-12)] and approved Anti-seize Lubricant (commercial service tool).

>> INSPECTION END

P0075, P0081 IVT CONTROL SOLENOID VALVE

< DTC/CIRCUIT DIAGNOSIS >

[VQ37VHR]

P0075, P0081 IVT CONTROL SOLENOID VALVE

Description

INFOID:000000005151712

Intake valve timing control solenoid valve is activated by ON/OFF pulse duty (ratio) signals from the ECM.

The intake valve timing control solenoid valve changes the oil amount and direction of flow through intake valve timing control unit or stops oil flow.

The longer pulse width advances valve angle.

The shorter pulse width retards valve angle.

When ON and OFF pulse widths become equal, the solenoid valve stops oil pressure flow to fix the intake valve angle at the control position.

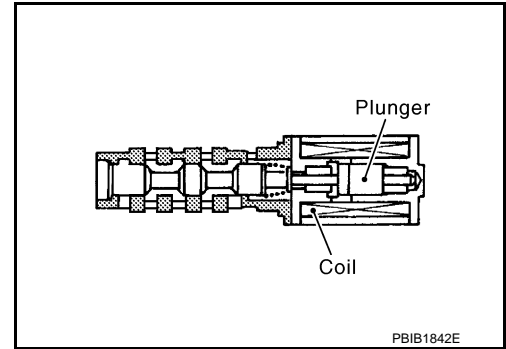

DTC Logic

INFOID:000000005151713

DTC DETECTION LOGIC

DTC No.	Trouble diagnosis name	DTC detecting condition	Possible cause
P0075	Intake valve timing control solenoid valve (bank 1) circuit	An improper voltage is sent to the ECM through intake valve timing control solenoid valve.	<ul style="list-style-type: none"> • Harness or connectors (Intake valve timing control solenoid valve circuit is open or shorted.) • Intake valve timing control solenoid valve
P0081	Intake valve timing control solenoid valve (bank 2) circuit		

DTC CONFIRMATION PROCEDURE

1. PRECONDITIONING

If DTC Confirmation Procedure has been previously conducted, always perform the following procedure before conducting the next test.

1. Turn ignition switch OFF and wait at least 10 seconds.
2. Turn ignition switch ON.
3. Turn ignition switch OFF and wait at least 10 seconds.

>> GO TO 2.

2. PERFORM DTC CONFIRMATION PROCEDURE

1. Start engine and let it idle for 5 seconds.
2. Check 1st trip DTC.

Is 1st trip DTC detected?

YES >> Go to [EC-162, "Diagnosis Procedure"](#).

NO >> INSPECTION END

Diagnosis Procedure

INFOID:000000005151714

1. CHECK INTAKE VALVE TIMING CONTROL SOLENOID VALVE POWER SUPPLY CIRCUIT

1. Turn ignition switch OFF.
2. Disconnect intake valve timing (IVT) control solenoid valve harness connector.
3. Turn ignition switch ON.
4. Check the voltage between intake valve timing control solenoid valve harness connector and ground.

DTC	IVT control solenoid valve			Ground	Voltage
	Bank	Connector	Terminal		
P0075	1	F28	2	Ground	Battery voltage
P0081	2	F29	2		

P0075, P0081 IVT CONTROL SOLENOID VALVE

[VQ37VHR]

< DTC/CIRCUIT DIAGNOSIS >

Is the inspection result normal?

- YES >> GO TO 3.
- NO >> GO TO 2.

2. DETECT MALFUNCTIONING PART

Check the following.

- Harness connectors E3, F1
- Harness for open or short between intake valve timing control solenoid valve and IPDM E/R

>> Repair open circuit, short to ground or short to power in harness or connectors.

3. CHECK INTAKE VALVE TIMING CONTROL SOLENOID VALVE OUTPUT SIGNAL CIRCUIT FOR OPEN AND SHORT

1. Turn ignition switch OFF.
2. Disconnect ECM harness connector.
3. Check the continuity between intake valve timing control solenoid valve harness connector and ECM harness connector.

DTC	IVT control solenoid valve			ECM		Continuity
	Bank	Connector	Terminal	Connector	Terminal	
P0075	1	F28	1	F101	18	Existed
P0081	2	F29	1		29	

4. Also check harness for short to ground and short to power.

Is the inspection result normal?

- YES >> GO TO 4.
- NO >> Repair open circuit, short to ground or short to power in harness or connectors.

4. CHECK INTAKE VALVE TIMING CONTROL SOLENOID VALVE

Refer to [EC-163, "Component Inspection"](#).

Is the inspection result normal?

- YES >> GO TO 5.
- NO >> Replace malfunctioning intake valve timing control solenoid valve.

5. CHECK INTERMITTENT INCIDENT

Refer to [GI-36, "Intermittent Incident"](#).

>> INSPECTION END

Component Inspection

INFOID:000000005151715

1. CHECK INTAKE VALVE TIMING CONTROL SOLENOID VALVE-I

1. Turn ignition switch OFF.
2. Disconnect intake valve timing control solenoid valve harness connector.
3. Check resistance between intake valve timing control solenoid valve terminals as follows.

Terminals	Resistance (Ω)
1 and 2	7.0 - 7.7 [at 20°C (68°F)]
1 or 2 and ground	∞ (Continuity should not exist)

Is the inspection result normal?

- YES >> GO TO 2.
- NO >> Replace malfunctioning intake valve timing control solenoid valve.

2. CHECK INTAKE VALVE TIMING CONTROL SOLENOID VALVE-II

1. Remove intake valve timing control solenoid valve.

P0075, P0081 IVT CONTROL SOLENOID VALVE

[VQ37VHR]

< DTC/CIRCUIT DIAGNOSIS >

2. Provide 12 V DC between intake valve timing control solenoid valve terminals 1 and 2, and then interrupt it. Make sure that the plunger moves as shown in the figure.

CAUTION:

Do not apply 12 V DC continuously for 5 seconds or more. Doing so may result in damage to the coil in intake valve timing control solenoid valve.

NOTE:

Always replace O-ring when intake valve timing control solenoid valve is removed.

Is the inspection result normal?

YES >> INSPECTION END

NO >> Replace malfunctioning intake valve timing control solenoid valve.

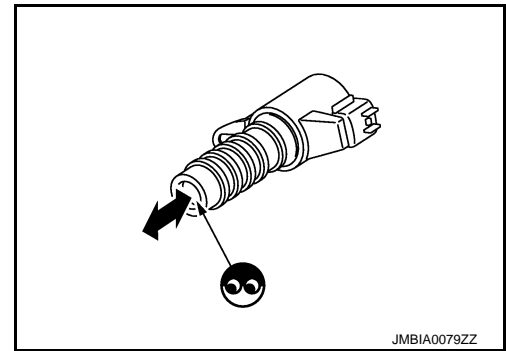

P0101, P010B MAF SENSOR

< DTC/CIRCUIT DIAGNOSIS >

[VQ37VHR]

P0101, P010B MAF SENSOR

Description

INFOID:000000005151716

The mass air flow sensor (1) is placed in the stream of intake air. It measures the intake flow rate by measuring a part of the entire intake flow. The mass air flow sensor controls the temperature of the hot wire to a certain amount. The heat generated by the hot wire is reduced as the intake air flows around it. The greater air flow, the greater the heat loss. Therefore, the electric current supplied to hot wire is changed to maintain the temperature of the hot wire as air flow increases. The ECM detects the air flow by means of this current change.

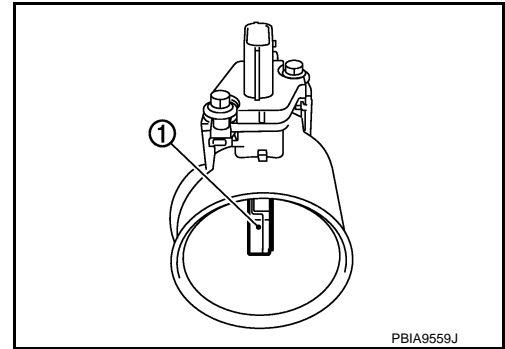

DTC Logic

INFOID:000000005151717

DTC DETECTION LOGIC

DTC No.	Trouble diagnosis name	DTC detecting condition		Possible cause
P0101	Mass air flow sensor (bank 1) circuit range/performance	A)	A high voltage from the sensor is sent to ECM under light load driving condition.	<ul style="list-style-type: none"> • Harness or connectors (The sensor circuit is open or shorted.) • Mass air flow sensor • EVAP control system pressure sensor
		B)	A low voltage from the sensor is sent to ECM under heavy load driving condition.	<ul style="list-style-type: none"> • Harness or connectors (The sensor circuit is open or shorted.) • Intake air leaks • Mass air flow sensor • EVAP control system pressure sensor • Intake air temperature sensor
P010B	Mass air flow sensor (bank 2) circuit range/performance	A)	A high voltage from the sensor is sent to ECM under light load driving condition.	<ul style="list-style-type: none"> • Harness or connectors (The sensor circuit is open or shorted.) • Mass air flow sensor • EVAP control system pressure sensor
		B)	A low voltage from the sensor is sent to ECM under heavy load driving condition.	<ul style="list-style-type: none"> • Harness or connectors (The sensor circuit is open or shorted.) • Intake air leaks • Mass air flow sensor • EVAP control system pressure sensor • Intake air temperature sensor

DTC CONFIRMATION PROCEDURE

1. PRECONDITIONING

If DTC Confirmation Procedure has been previously conducted, always perform the following procedure before conducting the next test.

1. Turn ignition switch OFF and wait at least 10 seconds.
2. Turn ignition switch ON.
3. Turn ignition switch OFF and wait at least 10 seconds.

>> GO TO 2.

P0101, P010B MAF SENSOR

< DTC/CIRCUIT DIAGNOSIS >

[VQ37VHR]

2. PERFORM DTC CONFIRMATION PROCEDURE FOR MALFUNCTION A

1. Start engine and warm it up to normal operating temperature.

NOTE:

If engine will not start or stops soon, wait at least 10 seconds with engine stopped (Ignition switch ON) instead of running engine at idle speed.

2. Run engine for at least 10 seconds at idle speed.
3. Check 1st trip DTC.

Is 1st trip DTC detected?

YES >> Go to [EC-167, "Diagnosis Procedure"](#).

NO-1 >> With CONSULT-III: GO TO 3.

NO-2 >> Without CONSULT-III: GO TO 5.

3. CHECK MASS AIR FLOW SENSOR FUNCTION

1. Turn ignition switch ON.
2. Start engine and warm it up to normal operating temperature.
If engine cannot be started, go to [EC-167, "Diagnosis Procedure"](#).
3. Select "DATA MONITOR" mode with CONSULT-III.
4. Check the voltage of "MAS A/F SE-B1/B2" with "DATA MONITOR".
5. Increases engine speed to about 4,000 rpm.
6. Monitor the linear voltage rise in response to engine speed increases.

Is the inspection result normal?

YES >> GO TO 4.

NO >> Go to [EC-167, "Diagnosis Procedure"](#).

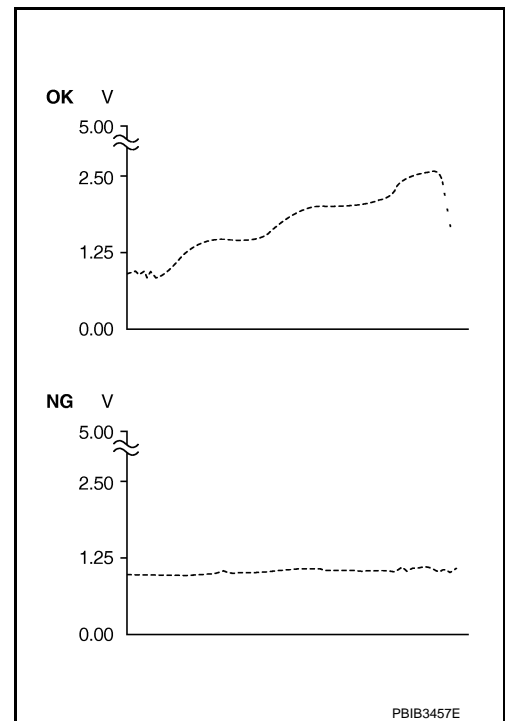

4. PERFORM DTC CONFIRMATION PROCEDURE FOR MALFUNCTION B

1. Maintain the following conditions for at least 10 consecutive seconds.

ENG SPEED	More than 1,400 rpm
TP SEN 1-B1	More than 1 V
TP SEN 2-B1	More than 1 V
TP SEN 1-B2	More than 1 V
TP SEN 2-B2	More than 1 V
Selector lever	Suitable position
Driving location	Driving vehicle uphill (Increased engine load) will help maintain the driving conditions required for this test.

CAUTION:

Always drive vehicle at a safe speed.

2. Check 1st trip DTC.

Is 1st trip DTC detected?

P0101, P010B MAF SENSOR

[VQ37VHR]

< DTC/CIRCUIT DIAGNOSIS >

- YES >> Go to [EC-167. "Diagnosis Procedure"](#).
NO >> INSPECTION END

5.PERFORM COMPONENT FUNCTION CHECK FOR MALFUNCTION B

Perform component function check. Refer to [EC-167. "Component Function Check"](#).

NOTE:

Use component function check to check the overall function of the mass air flow sensor circuit. During this check, a 1st trip DTC might not be confirmed.

Is the inspection result normal?

- YES >> INSPECTION END
NO >> Go to [EC-167. "Diagnosis Procedure"](#).

Component Function Check

INFOID:000000005151718

1.PERFORM COMPONENT FUNCTION CHECK FOR MALFUNCTION B

With GST

1. Start engine and warm it up to normal operating temperature.
2. Select Service \$01 with GST.
3. Check the mass air flow sensor signal with Service \$01.
4. Check for linear mass air flow sensor signal value rise in response to increases to about 4,000 rpm in engine speed.

Is the inspection result normal?

- YES >> INSPECTION END
NO >> Go to [EC-167. "Diagnosis Procedure"](#).

CALC LOAD	20%
COOLANT TEMP	95°C
SHORT FT #1	2%
LONG FT #1	0%
SHORT FT #2	4%
LONG FT #2	0%
ENGINE SPD	2637RPM
VEHICLE SPD	0MPH
IGN ADVANCE	41.0°
INTAKE AIR	41°C
MAF	14.1gm/sec
THROTTLE POS	3%

SEF534P

Diagnosis Procedure

INFOID:000000005151719

1.INSPECTION START

Confirm the detected malfunction (A or B). Refer to [EC-165. "DTC Logic"](#).

Which malfunction is detected?

- A >> GO TO 3.
B >> GO TO 2.

2.CHECK INTAKE SYSTEM

Check the following for connection.

- Air duct
- Vacuum hoses
- Intake air passage between air duct and intake manifold

Is the inspection result normal?

- YES >> GO TO 3.
NO >> Reconnect the parts.

3.CHECK GROUND CONNECTION

1. Turn ignition switch OFF.
2. Check ground connection M95. Refer to Ground Inspection in [GI-39. "Circuit Inspection"](#).

Is the inspection result normal?

- YES >> GO TO 4.
NO >> Repair or replace ground connection.

4.CHECK MAF SENSOR POWER SUPPLY CIRCUIT

1. Disconnect mass air flow (MAF) sensor harness connector.
2. Turn ignition switch ON.
3. Check the voltage between MAF sensor harness connector and ground.

P0101, P010B MAF SENSOR

< DTC/CIRCUIT DIAGNOSIS >

[VQ37VHR]

DTC	MAF sensor			Ground	Voltage
	Bank	Connector	Terminal		
P0101	1	F31	5	Ground	Battery voltage
P010B	2	F42	5		

Is the inspection result normal?

- YES >> GO TO 6.
NO >> GO TO 5.

5. DETECT MALFUNCTIONING PART

Check the following.

- Harness connectors E106, M6
- Harness connectors M116, F103
- Harness for open or short between mass air flow sensor and ECM
- Harness for open or short between mass air flow sensor and IPDM E/R

>> Repair open circuit, short to ground or short to power in harness or connectors.

6. CHECK MAF SENSOR GROUND CIRCUIT FOR OPEN AND SHORT

1. Turn ignition switch OFF.
2. Disconnect ECM harness connector.
3. Check the continuity between MAF sensor harness connector and ECM harness connector.

DTC	MAF sensor			ECM		Continuity
	Bank	Connector	Terminal	Connector	Terminal	
P0101	1	F31	4	F102	68	Existed
P010B	2	F42	4		94	

4. Also check harness for short to ground and short to power.

Is the inspection result normal?

- YES >> GO TO 7.
NO >> Repair open circuit, short to ground or short to power in harness or connectors.

7. CHECK MAF SENSOR INPUT SIGNAL CIRCUIT FOR OPEN AND SHORT

1. Check the continuity between MAF sensor harness connector and ECM harness connector.

DTC	MAF sensor			ECM		Continuity
	Bank	Connector	Terminal	Connector	Terminal	
P0101	1	F31	3	F102	77	Existed
P010B	2	F42	3		79	

2. Also check harness for short to ground and short to power.

Is the inspection result normal?

- YES >> GO TO 8.
NO >> Repair open circuit, short to ground or short to power in harness or connectors.

8. CHECK INTAKE AIR TEMPERATURE SENSOR

Check intake air temperature sensor.

Refer to [EC-183, "Component Inspection"](#).

Is the inspection result normal?

- YES >> GO TO 9.
NO >> Replace mass air flow sensor (bank 1) (with intake air temperature sensor).

9. CHECK EVAP CONTROL SYSTEM PRESSURE SENSOR

Refer to [EC-311, "Component Inspection"](#).

P0101, P010B MAF SENSOR

[VQ37VHR]

< DTC/CIRCUIT DIAGNOSIS >

Is the inspection result normal?

- YES >> GO TO 10.
- NO >> Replace EVAP control system pressure sensor.

10. CHECK MASS AIR FLOW SENSOR

Refer to [EC-169, "Component Inspection"](#).

Is the inspection result normal?

- YES >> GO TO 11.
- NO >> Replace malfunctioning mass air flow sensor.

11. CHECK INTERMITTENT INCIDENT

Refer to [GI-36, "Intermittent Incident"](#).

>> INSPECTION END

Component Inspection

INFOID:000000005151720

1. CHECK MASS AIR FLOW SENSOR-I

With CONSULT-III

1. Turn ignition switch OFF.
2. Reconnect all harness connectors disconnected.
3. Start engine and warm it up to normal operating temperature.
4. Connect CONSULT-III and select "DATA MONITOR" mode.
5. Select "MAS A/F SE-B1" and "MAS A/F SE-B2", and check the indication.

Monitor item	Condition	Indication (V)
MAS A/F SE-B1 MAS A/F SE-B2	Ignition switch ON (Engine stopped.)	Approx. 0.4
	Idle (Engine is warmed-up to normal operating temperature.)	0.7 - 1.2
	2,500 rpm (Engine is warmed-up to normal operating temperature.)	1.3 - 1.7
	Idle to about 4,000 rpm	0.7 - 1.2 to Approx. 2.4*

*: Check for linear voltage rise in response to engine being increased to about 4,000 rpm.

Without CONSULT-III

1. Turn ignition switch OFF.
2. Reconnect all harness connectors disconnected.
3. Start engine and warm it up to normal operating temperature.
4. Check the voltage between ECM harness connector terminals under the following conditions.

Connector	ECM		Condition	Voltage (V)
	+	-		
	Terminal	Terminal		
F102	77 [MAF sensor (bank 1) signal]	68	Ignition switch ON (Engine stopped.)	Approx. 0.4
			Idle (Engine is warmed-up to normal operating temperature.)	0.7 - 1.2
			2,500 rpm (Engine is warmed-up to normal operating temperature.)	1.3 - 1.7
			Idle to about 4,000 rpm	0.7 - 1.2 to Approx. 2.4*
	79 [MAF sensor (bank 2) signal]	94	Ignition switch ON (Engine stopped.)	Approx. 0.4
			Idle (Engine is warmed-up to normal operating temperature.)	0.7 - 1.2
			2,500 rpm (Engine is warmed-up to normal operating temperature.)	1.3 - 1.7
			Idle to about 4,000 rpm	0.7 - 1.2 to Approx. 2.4*

*: Check for linear voltage rise in response to engine being increased to about 4,000 rpm.

P0101, P010B MAF SENSOR

[VQ37VHR]

< DTC/CIRCUIT DIAGNOSIS >

Is the inspection result normal?

- YES >> INSPECTION END
- NO >> GO TO 2.

2. CHECK FOR THE CAUSE OF UNEVEN AIR FLOW THROUGH MASS AIR FLOW SENSOR

1. Turn ignition switch OFF.
2. Check for the cause of uneven air flow through mass air flow sensor. Refer to the following.
 - Crushed air ducts
 - Malfunctioning seal of air cleaner element
 - Uneven dirt of air cleaner element
 - Improper specification of intake air system parts

Is the inspection result normal?

- YES >> GO TO 4.
- NO >> GO TO 3.

3. CHECK MASS AIR FLOW SENSOR-II

Ⓟ With CONSULT-III

1. Repair or replace malfunctioning part.
2. Start engine and warm it up to normal operating temperature.
3. Connect CONSULT-III and select "DATA MONITOR" mode.
4. Select "MAS A/F SE-B1" and "MAS A/F SE-B2", and check the indication.

Monitor item	Condition	Indication (V)
MAS A/F SE-B1 MAS A/F SE-B2	Ignition switch ON (Engine stopped.)	Approx. 0.4
	Idle (Engine is warmed-up to normal operating temperature.)	0.7 - 1.2
	2,500 rpm (Engine is warmed-up to normal operating temperature.)	1.3 - 1.7
	Idle to about 4,000 rpm	0.7 - 1.2 to Approx. 2.4*

*: Check for linear voltage rise in response to engine being increased to about 4,000 rpm.

ⓧ Without CONSULT-III

1. Repair or replace malfunctioning part.
2. Start engine and warm it up to normal operating temperature.
3. Check the voltage between ECM harness connector terminals under the following conditions.

Connector	ECM		Condition	Voltage (V)
	+	-		
	Terminal	Terminal		
F102	77 [MAF sensor (bank 1) signal]	68	Ignition switch ON (Engine stopped.)	Approx. 0.4
			Idle (Engine is warmed-up to normal operating temperature.)	0.7 - 1.2
			2,500 rpm (Engine is warmed-up to normal operating temperature.)	1.3 - 1.7
			Idle to about 4,000 rpm	0.7 - 1.2 to Approx. 2.4*
	79 [MAF sensor (bank 2) signal]	94	Ignition switch ON (Engine stopped.)	Approx. 0.4
			Idle (Engine is warmed-up to normal operating temperature.)	0.7 - 1.2
			2,500 rpm (Engine is warmed-up to normal operating temperature.)	1.3 - 1.7
			Idle to about 4,000 rpm	0.7 - 1.2 to Approx. 2.4*

*: Check for linear voltage rise in response to engine being increased to about 4,000 rpm.

Is the inspection result normal?

- YES >> INSPECTION END
- NO >> GO TO 4.

P0101, P010B MAF SENSOR

< DTC/CIRCUIT DIAGNOSIS >

[VQ37VHR]

4. CHECK MASS AIR FLOW SENSOR-III

With CONSULT-III

1. Turn ignition switch OFF.
2. Disconnect mass air flow sensor harness connector and reconnect it again.
3. Start engine and warm it up to normal operating temperature.
4. Connect CONSULT-III and select "DATA MONITOR" mode.
5. Select "MAS A/F SE-B1" and "MAS A/F SE-B2", and check the indication.

Monitor item	Condition	Indication (V)
MAS A/F SE-B1 MAS A/F SE-B2	Ignition switch ON (Engine stopped.)	Approx. 0.4
	Idle (Engine is warmed-up to normal operating temperature.)	0.7 - 1.2
	2,500 rpm (Engine is warmed-up to normal operating temperature.)	1.3 - 1.7
	Idle to about 4,000 rpm	0.7 - 1.2 to Approx. 2.4*

*: Check for linear voltage rise in response to engine being increased to about 4,000 rpm.

Without CONSULT-III

1. Turn ignition switch OFF.
2. Disconnect mass air flow sensor harness connector and reconnect it again.
3. Start engine and warm it up to normal operating temperature.
4. Check the voltage between ECM harness connector terminals under the following conditions.

Connector	ECM		Condition	Voltage (V)
	+	-		
	Terminal	Terminal		
F102	77 [MAF sensor (bank 1) signal]	68	Ignition switch ON (Engine stopped.)	Approx. 0.4
			Idle (Engine is warmed-up to normal operating temperature.)	0.7 - 1.2
			2,500 rpm (Engine is warmed-up to normal operating temperature.)	1.3 - 1.7
			Idle to about 4,000 rpm	0.7 - 1.2 to Approx. 2.4*
	79 [MAF sensor (bank 2) signal]	94	Ignition switch ON (Engine stopped.)	Approx. 0.4
			Idle (Engine is warmed-up to normal operating temperature.)	0.7 - 1.2
			2,500 rpm (Engine is warmed-up to normal operating temperature.)	1.3 - 1.7
			Idle to about 4,000 rpm	0.7 - 1.2 to Approx. 2.4*

*: Check for linear voltage rise in response to engine being increased to about 4,000 rpm.

Is the inspection result normal?

- YES >> INSPECTION END
 NO >> Clean or replace malfunctioning mass air flow sensor.

P0102, P0103, P010C, P010D MAF SENSOR

< DTC/CIRCUIT DIAGNOSIS >

[VQ37VHR]

P0102, P0103, P010C, P010D MAF SENSOR

Description

INFOID:000000005151721

The mass air flow sensor (1) is placed in the stream of intake air. It measures the intake flow rate by measuring a part of the entire intake flow. The mass air flow sensor controls the temperature of the hot wire to a certain amount. The heat generated by the hot wire is reduced as the intake air flows around it. The more air, the greater the heat loss.

Therefore, the electric current supplied to hot wire is changed to maintain the temperature of the hot wire as air flow increases. The ECM detects the air flow by means of this current change.

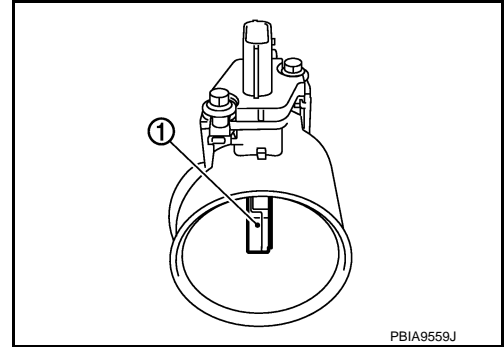

DTC Logic

INFOID:000000005151722

DTC DETECTION LOGIC

DTC No.	Trouble diagnosis name	DTC detecting condition	Possible cause
P0102	Mass air flow sensor (bank 1) circuit low input	An excessively low voltage from the sensor is sent to ECM.	<ul style="list-style-type: none">• Harness or connectors (The sensor circuit is open or shorted.)• Intake air leaks• Mass air flow sensor
P0103	Mass air flow sensor (bank 1) circuit high input	An excessively high voltage from the sensor is sent to ECM.	<ul style="list-style-type: none">• Harness or connectors (The sensor circuit is open or shorted.)• Mass air flow sensor
P010C	Mass air flow sensor (bank 2) circuit low input	An excessively low voltage from the sensor is sent to ECM.	<ul style="list-style-type: none">• Harness or connectors (The sensor circuit is open or shorted.)• Intake air leaks• Mass air flow sensor
P010D	Mass air flow sensor (bank 2) circuit high input	An excessively high voltage from the sensor is sent to ECM.	<ul style="list-style-type: none">• Harness or connectors (The sensor circuit is open or shorted.)• Mass air flow sensor

DTC CONFIRMATION PROCEDURE

1. PRECONDITIONING

If DTC Confirmation Procedure has been previously conducted, always perform the following procedure before conducting the next test.

1. Turn ignition switch OFF and wait at least 10 seconds.
2. Turn ignition switch ON.
3. Turn ignition switch OFF and wait at least 10 seconds.

Which DTC is detected?

P0102, P010C >> GO TO 2.

P0103, P010D >> GO TO 3.

2. PERFORM DTC CONFIRMATION PROCEDURE FOR DTC P0102 AND P010C

1. Start engine and wait at least 5 seconds.
2. Check DTC.

Is DTC detected?

YES >> Go to [EC-173. "Diagnosis Procedure"](#).

NO >> INSPECTION END

3. PERFORM DTC CONFIRMATION PROCEDURE FOR DTC P0103 AND P010D-I

1. Turn ignition switch ON and wait at least 5 seconds.
2. Check DTC.

P0102, P0103, P010C, P010D MAF SENSOR

[VQ37VHR]

< DTC/CIRCUIT DIAGNOSIS >

Is DTC detected?

- YES >> Go to [EC-173, "Diagnosis Procedure"](#).
- NO >> GO TO 4.

4.PERFORM DTC CONFIRMATION PROCEDURE FOR DTC P0103 AND P010D-II

1. Start engine and wait at least 5 seconds.
2. Check DTC.

Is DTC detected?

- YES >> Go to [EC-173, "Diagnosis Procedure"](#).
- NO >> INSPECTION END

Diagnosis Procedure

INFOID:000000005151723

1.INSPECTION START

Confirm the detected DTC.

Which DTC is detected?

- P0102, P010C>>GO TO 2.
- P0103, P010D>>GO TO 3.

2.CHECK INTAKE SYSTEM

Check the following for connection.

- Air duct
- Vacuum hoses
- Intake air passage between air duct to intake manifold

Is the inspection result normal?

- YES >> GO TO 3.
- NO >> Reconnect the parts.

3.CHECK GROUND CONNECTION

1. Turn ignition switch OFF.
2. Check ground connection M95. Refer to Ground Inspection in [GI-39, "Circuit Inspection"](#).

Is the inspection result normal?

- YES >> GO TO 4.
- NO >> Repair or replace ground connection.

4.CHECK MAF SENSOR POWER SUPPLY CIRCUIT

1. Disconnect mass air flow (MAF) sensor harness connector.
2. Turn ignition switch ON.
3. Check the voltage between MAF sensor harness connector and ground.

DTC	MAF sensor			Ground	Voltage
	Bank	Connector	Terminal		
P0102, P0103	1	F31	5	Ground	Battery voltage
P010C, P010D	2	F42	5		

Is the inspection result normal?

- YES >> GO TO 6.
- NO >> GO TO 5.

5.DETECT MALFUNCTIONING PART

Check the following.

- Harness connectors E106, M6
- Harness connectors M116, F103
- Harness for open or short between mass air flow sensor and ECM
- Harness for open or short between mass air flow sensor and IPDM E/R

>> Repair open circuit, short to ground or short to power in harness or connectors.

P0102, P0103, P010C, P010D MAF SENSOR

< DTC/CIRCUIT DIAGNOSIS >

[VQ37VHR]

6. CHECK MAF SENSOR GROUND CIRCUIT FOR OPEN AND SHORT

1. Turn ignition switch OFF.
2. Disconnect ECM harness connector.
3. Check the continuity between MAF sensor harness connector and ECM harness connector.

DTC	MAF sensor			ECM		Continuity
	Bank	Connector	Terminal	Connector	Terminal	
P0102, P0103	1	F31	4	F102	68	Existed
P010C, P010D	2	F42	4		94	

4. Also check harness for short to ground and short to power.

Is the inspection result normal?

YES >> GO TO 7.

NO >> Repair open circuit, short to ground or short to power in harness or connectors.

7. CHECK MAF SENSOR INPUT SIGNAL CIRCUIT FOR OPEN AND SHORT

1. Check the continuity between MAF sensor harness connector and ECM harness connector.

DTC	MAF sensor			ECM		Continuity
	Bank	Connector	Terminal	Connector	Terminal	
P0102, P0103	1	F31	3	F102	77	Existed
P010C, P010D	2	F42	3		79	

2. Also check harness for short to ground and short to power.

Is the inspection result normal?

YES >> GO TO 8.

NO >> Repair open circuit, short to ground or short to power in harness or connectors.

8. CHECK MASS AIR FLOW SENSOR

Refer to [EC-174. "Component Inspection"](#).

Is the inspection result normal?

YES >> GO TO 9.

NO >> Replace malfunctioning mass air flow sensor.

9. CHECK INTERMITTENT INCIDENT

Refer to [GI-36. "Intermittent Incident"](#).

>> INSPECTION END

Component Inspection

INFOID:000000005151724

1. CHECK MASS AIR FLOW SENSOR-I

With CONSULT-III

1. Turn ignition switch OFF.
2. Reconnect all harness connectors disconnected.
3. Start engine and warm it up to normal operating temperature.
4. Connect CONSULT-III and select "DATA MONITOR" mode.
5. Select "MAS A/F SE-B1" and "MAS A/F SE-B2", and check the indication.

Monitor item	Condition	Indication (V)
MAS A/F SE-B1 MAS A/F SE-B2	Ignition switch ON (Engine stopped.)	Approx. 0.4
	Idle (Engine is warmed-up to normal operating temperature.)	0.7 - 1.2
	2,500 rpm (Engine is warmed-up to normal operating temperature.)	1.3 - 1.7
	Idle to about 4,000 rpm	0.7 - 1.2 to Approx. 2.4*

P0102, P0103, P010C, P010D MAF SENSOR

< DTC/CIRCUIT DIAGNOSIS >

[VQ37VHR]

*: Check for linear voltage rise in response to engine being increased to about 4,000 rpm.

⊗ Without CONSULT-III

1. Turn ignition switch OFF.
2. Reconnect all harness connectors disconnected.
3. Start engine and warm it up to normal operating temperature.
4. Check the voltage between ECM harness connector terminals under the following conditions.

ECM			Condition	Voltage (V)
Connector	+	-		
	Terminal	Terminal		
F102	77 [MAF sensor (bank 1) signal]	68	Ignition switch ON (Engine stopped.)	Approx. 0.4
			Idle (Engine is warmed-up to normal operating temperature.)	0.7 - 1.2
			2,500 rpm (Engine is warmed-up to normal operating temperature.)	1.3 - 1.7
			Idle to about 4,000 rpm	0.7 - 1.2 to Approx. 2.4*
	79 [MAF sensor (bank 2) signal]	94	Ignition switch ON (Engine stopped.)	Approx. 0.4
			Idle (Engine is warmed-up to normal operating temperature.)	0.7 - 1.2
			2,500 rpm (Engine is warmed-up to normal operating temperature.)	1.3 - 1.7
			Idle to about 4,000 rpm	0.7 - 1.2 to Approx. 2.4*

*: Check for linear voltage rise in response to engine being increased to about 4,000 rpm.

Is the inspection result normal?

- YES >> INSPECTION END
 NO >> GO TO 2.

2. CHECK FOR THE CAUSE OF UNEVEN AIR FLOW THROUGH MASS AIR FLOW SENSOR

1. Turn ignition switch OFF.
2. Check for the cause of uneven air flow through mass air flow sensor. Refer to the following.
 - Crushed air ducts
 - Malfunctioning seal of air cleaner element
 - Uneven dirt of air cleaner element
 - Improper specification of intake air system parts

Is the inspection result normal?

- YES >> GO TO 4.
 NO >> GO TO 3.

3. CHECK MASS AIR FLOW SENSOR-II

Ⓜ With CONSULT-III

1. Repair or replace malfunctioning part.
2. Start engine and warm it up to normal operating temperature.
3. Connect CONSULT-III and select "DATA MONITOR" mode.
4. Select "MAS A/F SE-B1" and "MAS A/F SE-B2", and check the indication.

Monitor item	Condition	Indication (V)
MAS A/F SE-B1 MAS A/F SE-B2	Ignition switch ON (Engine stopped.)	Approx. 0.4
	Idle (Engine is warmed-up to normal operating temperature.)	0.7 - 1.2
	2,500 rpm (Engine is warmed-up to normal operating temperature.)	1.3 - 1.7
	Idle to about 4,000 rpm	0.7 - 1.2 to Approx. 2.4*

*: Check for linear voltage rise in response to engine being increased to about 4,000 rpm.

⊗ Without CONSULT-III

1. Repair or replace malfunctioning part.
2. Start engine and warm it up to normal operating temperature.

P0102, P0103, P010C, P010D MAF SENSOR

< DTC/CIRCUIT DIAGNOSIS >

[VQ37VHR]

3. Check the voltage between ECM harness connector terminals under the following conditions.

Connector	ECM		Condition	Voltage (V)
	+	-		
	Terminal	Terminal		
F102	77 [MAF sensor (bank 1) signal]	68	Ignition switch ON (Engine stopped.)	Approx. 0.4
			Idle (Engine is warmed-up to normal operating temperature.)	0.7 - 1.2
			2,500 rpm (Engine is warmed-up to normal operating temperature.)	1.3 - 1.7
			Idle to about 4,000 rpm	0.7 - 1.2 to Approx. 2.4*
	79 [MAF sensor (bank 2) signal]	94	Ignition switch ON (Engine stopped.)	Approx. 0.4
			Idle (Engine is warmed-up to normal operating temperature.)	0.7 - 1.2
			2,500 rpm (Engine is warmed-up to normal operating temperature.)	1.3 - 1.7
			Idle to about 4,000 rpm	0.7 - 1.2 to Approx. 2.4*

*: Check for linear voltage rise in response to engine being increased to about 4,000 rpm.

Is the inspection result normal?

YES >> INSPECTION END

NO >> GO TO 4.

4. CHECK MASS AIR FLOW SENSOR-III

With CONSULT-III

1. Turn ignition switch OFF.
2. Disconnect mass air flow sensor harness connector and reconnect it again.
3. Start engine and warm it up to normal operating temperature.
4. Connect CONSULT-III and select "DATA MONITOR" mode.
5. Select "MAS A/F SE-B1" and "MAS A/F SE-B2", and check the indication.

Monitor item	Condition	Indication (V)
MAS A/F SE-B1 MAS A/F SE-B2	Ignition switch ON (Engine stopped.)	Approx. 0.4
	Idle (Engine is warmed-up to normal operating temperature.)	0.7 - 1.2
	2,500 rpm (Engine is warmed-up to normal operating temperature.)	1.3 - 1.7
	Idle to about 4,000 rpm	0.7 - 1.2 to Approx. 2.4*

*: Check for linear voltage rise in response to engine being increased to about 4,000 rpm.

Without CONSULT-III

1. Turn ignition switch OFF.
2. Disconnect mass air flow sensor harness connector and reconnect it again.
3. Start engine and warm it up to normal operating temperature.
4. Check the voltage between ECM harness connector terminals under the following conditions.

P0102, P0103, P010C, P010D MAF SENSOR

< DTC/CIRCUIT DIAGNOSIS >

[VQ37VHR]

ECM			Condition	Voltage (V)
Connector	+ Terminal	- Terminal		
F102	77 [MAF sensor (bank 1) signal]	68	Ignition switch ON (Engine stopped.)	Approx. 0.4
			Idle (Engine is warmed-up to normal operating temperature.)	0.7 - 1.2
			2,500 rpm (Engine is warmed-up to normal operating temperature.)	1.3 - 1.7
			Idle to about 4,000 rpm	0.7 - 1.2 to Approx. 2.4*
	79 [MAF sensor (bank 2) signal]	94	Ignition switch ON (Engine stopped.)	Approx. 0.4
			Idle (Engine is warmed-up to normal operating temperature.)	0.7 - 1.2
			2,500 rpm (Engine is warmed-up to normal operating temperature.)	1.3 - 1.7
			Idle to about 4,000 rpm	0.7 - 1.2 to Approx. 2.4*

*: Check for linear voltage rise in response to engine being increased to about 4,000 rpm.

Is the inspection result normal?

- YES >> INSPECTION END
- NO >> Clean or replace malfunctioning mass air flow sensor.

A
EC
C
D
E
F
G
H
I
J
K
L
M
N
O
P

P010A MANIFOLD ABSOLUTE PRESSURE SENSOR

< DTC/CIRCUIT DIAGNOSIS >

[VQ37VHR]

P010A MANIFOLD ABSOLUTE PRESSURE SENSOR

Description

INFOID:000000005151725

The manifold absolute pressure (MAP) sensor is placed at intake manifold collector. It detects intake manifold pressure and sends the voltage signal to the ECM.

The sensor uses a silicon diaphragm which is sensitive to the change in pressure. As the pressure increases, the voltage rises.

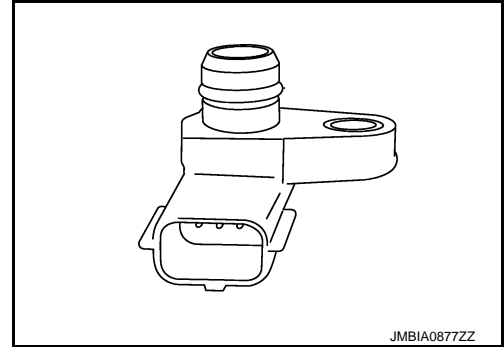

JMBIA0877ZZ

DTC Logic

INFOID:000000005151726

DTC DETECTION LOGIC

NOTE:

If DTC P010A is displayed with DTC P0643, first perform the trouble diagnosis for DTC P0643.

Refer to [EC-364, "DTC Logic"](#).

DTC No.	Trouble diagnosis name	DTC detecting condition	Possible cause
P010A	Manifold absolute pressure sensor circuit	<ul style="list-style-type: none">An excessively low voltage from the sensor is sent to ECM.An excessively high voltage from the sensor is sent to ECM.	<ul style="list-style-type: none">Harness or connectors (The sensor circuit is open or shorted.)Manifold absolute pressure (MAP) sensor

DTC CONFIRMATION PROCEDURE

1. PRECONDITIONING

If DTC Confirmation Procedure has been previously conducted, always perform the following procedure before conducting the next test.

- Turn ignition switch OFF and wait at least 10 seconds.
- Turn ignition switch ON.
- Turn ignition switch OFF and wait at least 10 seconds.

>> GO TO 2.

2. PERFORM DTC CONFIRMATION PROCEDURE

- Start engine and let it idle for 10 seconds.
- Check 1st trip DTC.

Is 1st trip DTC detected?

- YES >> Go to [EC-178, "Diagnosis Procedure"](#).
NO >> INSPECTION END

Diagnosis Procedure

INFOID:000000005151727

1. CHECK GROUND CONNECTION

- Turn ignition switch OFF.
- Check ground connection M95. Refer to Ground Inspection in [GI-39, "Circuit Inspection"](#).

Is the inspection result normal?

- YES >> GO TO 2.
NO >> Repair or replace ground connection.

2. CHECK MAP SENSOR POWER SUPPLY CIRCUIT

- Disconnect manifold absolute pressure (MAP) sensor harness connector.

P010A MANIFOLD ABSOLUTE PRESSURE SENSOR

[VQ37VHR]

< DTC/CIRCUIT DIAGNOSIS >

2. Turn ignition switch ON.
3. Check the voltage between MAP sensor harness connector and ground.

MAP sensor		Ground	Voltage (V)
Connector	Terminal		
F50	1	Ground	Approx. 5

Is the inspection result normal?

YES >> GO TO 3.

NO >> Repair open circuit, short to ground or short to power in harness or connectors.

3.CHECK MAP SENSOR GROUND CIRCUIT FOR OPEN AND SHORT

1. Turn ignition switch OFF.
2. Disconnect ECM harness connector.
3. Check the continuity between MAP sensor harness connector and ECM harness connector.

MAP sensor		ECM		Continuity
Connector	Terminal	Connector	Terminal	
F50	3	F102	96	Existed

4. Also check harness for short to ground and power.

Is the inspection result normal?

YES >> GO TO 4.

NO >> Repair open circuit, short to ground or short to power in harness or connectors.

4.CHECK MAP SENSOR INPUT SIGNAL CIRCUIT FOR OPEN AND SHORT

1. Check the continuity between MAP sensor harness connector and ECM harness connector.

MAP sensor		ECM		Continuity
Connector	Terminal	Connector	Terminal	
F50	2	F101	38	Existed

2. Also check harness for short to ground and power.

Is the inspection result normal?

YES >> GO TO 5.

NO >> Repair open circuit, short to ground or short to power in harness or connectors.

5.CHECK MAP SENSOR

Refer to [EC-179, "Component Inspection"](#).

Is the inspection result normal?

YES >> GO TO 6.

NO >> Replace MAP sensor.

6.CHECK INTERMITTENT INCIDENT

Refer to [GI-36, "Intermittent Incident"](#).

>> INSPECTION END

Component Inspection

INFOID:000000005151728

1.CHECK MAP SENSOR-I

1. Turn ignition switch OFF.
2. Start engine and warm it up to normal operating temperature.
3. Turn ignition switch OFF, wait at least 5 seconds and then turn ON.
4. Check the voltage between ECM harness connector terminals as follows.

P010A MANIFOLD ABSOLUTE PRESSURE SENSOR

< DTC/CIRCUIT DIAGNOSIS >

[VQ37VHR]

ECM			
+		-	
Connector	Terminal	Connector	Terminal
F101	38	F102	96

NOTE:

- To avoid the influence of intake manifold vacuum, check the voltage 1 or more minutes past after engine is stopped.
- Because the sensor is absolute pressure sensor, output value may differ depending on atmospheric pressure and altitude.

5. Measure the atmospheric pressure.

NOTE:

As the atmospheric pressure described on the synoptic chart is the value at sea level, compensate the pressure with the following chart.

Altitude (m)	Compensated pressure (hPa)
0	0
200	-24
400	-47
600	-70
800	-92
1000	-114
1500	-168
2000	-218

6. Check the manifold absolute pressure sensor value corresponding to the atmospheric pressure.

Atmospheric pressure (hPa)	Voltage (V)
800	3.1 – 3.7
850	3.3 – 3.9
900	3.5 – 4.1
950	3.8 – 4.3
1000	4.0 – 4.6
1050	4.2 – 4.8

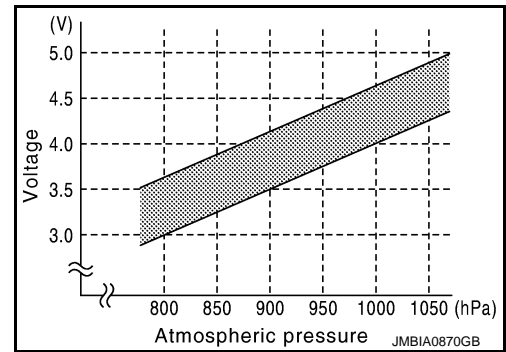

Is the inspection result normal?

YES >> GO TO 2.

NO >> Replace MAP sensor.

2. CHECK MAP SENSOR-II

1. Start engine and let it idle.
2. Check intake manifold vacuum.
3. Check the voltage between ECM harness connector terminals as per the following.

ECM			
+		-	
Connector	Terminal	Connector	Terminal
F101	38	F102	96

4. Confirm the difference of the voltage when engine is stopped and at idling is within the values shown in the following chart.

P010A MANIFOLD ABSOLUTE PRESSURE SENSOR

< DTC/CIRCUIT DIAGNOSIS >

[VQ37VHR]

Intake manifold vacuum [kPa (mmHg)]	Voltage difference (V)
-40 (-400)	1.5 – 2.0
-53.3 (-400)	2.0 – 2.6
-66.7 (-500)	2.6 – 3.2
-80 (-600)	3.2 – 3.8

Is the inspection result normal?

YES >> INSPECTION END
NO >> Replace MAP sensor.

A

EC

C

D

E

F

G

H

I

J

K

L

M

N

O

P

P0112, P0113 IAT SENSOR

< DTC/CIRCUIT DIAGNOSIS >

[VQ37VHR]

P0112, P0113 IAT SENSOR

Description

INFOID:000000005151729

The intake air temperature sensor is built-into the mass air flow sensor (bank 1) (1). The sensor detects intake air temperature and transmits a signal to the ECM.

The temperature sensing unit uses a thermistor which is sensitive to the change in temperature. Electrical resistance of the thermistor decreases in response to the rise in temperature.

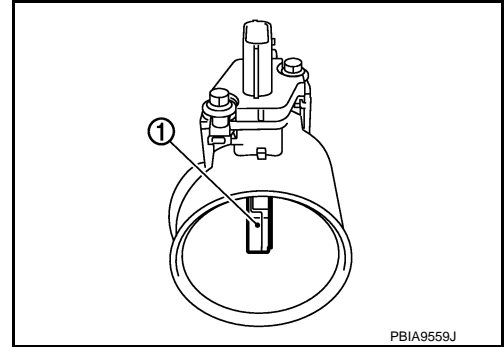

<Reference data>

Intake air temperature [°C (°F)]	Voltage* (V)	Resistance (kΩ)
25 (77)	3.3	1.800 - 2.200
80 (176)	1.2	0.283 - 0.359

*: These data are reference values and are measured between ECM terminals 67 (Intake air temperature sensor) and 68 (Sensor ground).

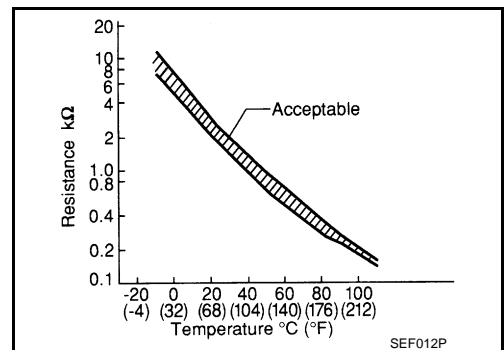

DTC Logic

INFOID:000000005151730

DTC DETECTION LOGIC

DTC No.	Trouble diagnosis name	DTC detecting condition	Possible cause
P0112	Intake air temperature sensor circuit low input	An excessively low voltage from the sensor is sent to ECM.	<ul style="list-style-type: none"> • Harness or connectors (The sensor circuit is open or shorted.) • Intake air temperature sensor
P0113	Intake air temperature sensor circuit high input	An excessively high voltage from the sensor is sent to ECM.	

DTC CONFIRMATION PROCEDURE

1. PRECONDITIONING

If DTC Confirmation Procedure has been previously conducted, always perform the following procedure before conducting the next test.

1. Turn ignition switch OFF and wait at least 10 seconds.
2. Turn ignition switch ON.
3. Turn ignition switch OFF and wait at least 10 seconds.

>> GO TO 2.

2. PERFORM DTC CONFIRMATION PROCEDURE

1. Turn ignition switch ON and wait at least 5 seconds.
2. Check 1st trip DTC.

Is 1st trip DTC detected?

- YES >> Go to [EC-183, "Diagnosis Procedure"](#).
 NO >> INSPECTION END

P0112, P0113 IAT SENSOR

[VQ37VHR]

< DTC/CIRCUIT DIAGNOSIS >

Diagnosis Procedure

INFOID:000000005151731

1. CHECK GROUND CONNECTION

1. Turn ignition switch OFF.
2. Check ground connection M95. Refer to Ground Inspection in [GI-39. "Circuit Inspection"](#).

Is the inspection result normal?

- YES >> GO TO 2.
NO >> Repair or replace ground connection.

2. CHECK INTAKE AIR TEMPERATURE SENSOR POWER SUPPLY CIRCUIT

1. Disconnect mass air flow (MAF) sensor (bank 1) (intake air temperature sensor is built-into) harness connector.
2. Turn ignition switch ON.
3. Check the voltage between mass air flow sensor (bank 1) harness connector and ground.

MAF sensor (bank 1)		Ground	Voltage (V)
Connector	Terminal		
F31	2	Ground	Approx. 5

Is the inspection result normal?

- YES >> GO TO 3.
NO >> Repair open circuit, short to ground or short to power in harness or connectors.

3. CHECK INTAKE AIR TEMPERATURE SENSOR GROUND CIRCUIT FOR OPEN AND SHORT

1. Turn ignition switch OFF.
2. Disconnect ECM harness connector.
3. Check the continuity between mass air flow sensor (bank 1) harness connector and ECM harness connector.

MAF sensor (bank 1)		ECM		Continuity
Connector	Terminal	Connector	Terminal	
F31	1	F102	68	Existed

4. Also check harness for short to ground and short to power.

Is the inspection result normal?

- YES >> GO TO 4.
NO >> Repair open circuit, short to ground or short to power in harness or connectors.

4. CHECK INTAKE AIR TEMPERATURE SENSOR

Refer to [EC-183. "Component Inspection"](#).

Is the inspection result normal?

- YES >> GO TO 5.
NO >> Replace mass air flow sensor (bank 1) (with intake air temperature sensor).

5. CHECK INTERMITTENT INCIDENT

Refer to [GI-36. "Intermittent Incident"](#).

>> INSPECTION END

Component Inspection

INFOID:000000005151732

1. CHECK INTAKE AIR TEMPERATURE SENSOR

1. Turn ignition switch OFF.
2. Disconnect mass air flow sensor (bank 1) harness connector.
3. Check resistance between mass air flow sensor (bank 1) terminals as follows.

P0112, P0113 IAT SENSOR

[VQ37VHR]

< DTC/CIRCUIT DIAGNOSIS >

Terminals	Condition		Resistance (k Ω)
1 and 2	Temperature [$^{\circ}$ C ($^{\circ}$ F)]	25 (77)	1.800 - 2.200

Is the inspection result normal?

YES >> INSPECTION END

NO >> Replace mass air flow sensor (bank 1) (with intake air temperature sensor).

P0116 ECT SENSOR

< DTC/CIRCUIT DIAGNOSIS >

[VQ37VHR]

P0116 ECT SENSOR

Description

INFOID:000000005151733

The engine coolant temperature sensor is used to detect the engine coolant temperature. The sensor modifies a voltage signal from the ECM. The modified signal returns to the ECM as the engine coolant temperature input. The sensor uses a thermistor which is sensitive to the change in temperature. The electrical resistance of the thermistor decreases as temperature increases.

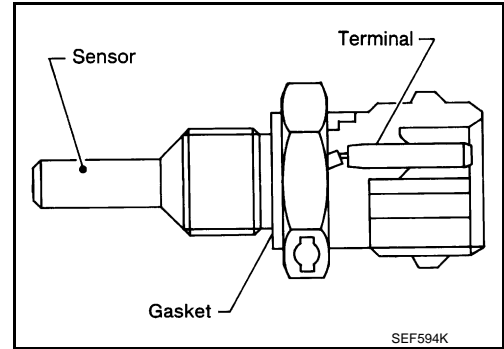

<Reference data>

Engine coolant temperature [°C (°F)]	Voltage* (V)	Resistance (kΩ)
-10 (14)	4.4	7.0 - 11.4
20 (68)	3.5	2.37 - 2.63
50 (122)	2.2	0.68 - 1.00
90 (194)	0.9	0.236 - 0.260

*: These data are reference values and are measured between ECM terminals 71 (Engine coolant temperature sensor) and 84 (Sensor ground).

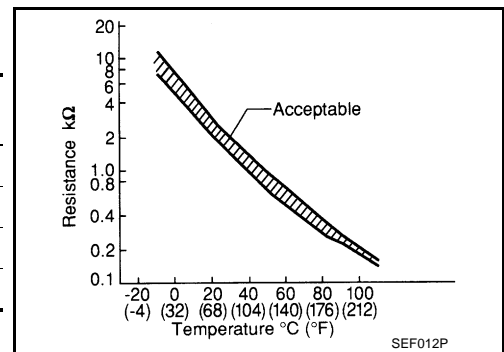

DTC Logic

INFOID:000000005151734

DTC DETECTION LOGIC

NOTE:

If DTC P0116 is displayed with P0117 or P0118, first perform the trouble diagnosis for DTC P0117, P0118. Refer to [EC-187, "DTC Logic"](#).

DTC No.	Trouble diagnosis name	DTC detecting condition	Possible cause
P0116	Engine coolant temperature sensor circuit range/performance	Engine coolant temperature signal from engine coolant temperature sensor does not fluctuate, even when some time has passed after starting the engine with pre-warming up condition.	<ul style="list-style-type: none"> Harness or connectors (High or low resistance in the circuit) Engine coolant temperature sensor

DTC CONFIRMATION PROCEDURE

1. PRECONDITIONING

If DTC Confirmation Procedure has been previously conducted, always perform the following procedure before conducting the next test.

- Turn ignition switch OFF and wait at least 10 seconds.
- Turn ignition switch ON.
- Turn ignition switch OFF and wait at least 10 seconds.

TEST CONDITION:

Before performing the following procedure, do not add fuel.

>> GO TO 2.

2. PERFORM DTC CONFIRMATION PROCEDURE

- Start engine and warm it up to normal operating temperature.
- Rev engine up to 2,000 rpm for more than 10 minutes.
- Move the vehicle to a cool place, then stop engine.

P0116 ECT SENSOR

[VQ37VHR]

< DTC/CIRCUIT DIAGNOSIS >

4. Check resistance between "fuel level sensor unit and fuel pump (main)" terminals 4 and 5.
5. Soak the vehicle until the resistance between "fuel level sensor unit and fuel pump (main)" terminals 4 and 5 becomes 0.5 kΩ higher than the value measured before soaking.

CAUTION:

Never turn ignition switch ON during soaking.

NOTE:

Soak time changes depending on ambient air temperature. It may take several hours.

6. Start engine and let it idle for 20 minutes.
7. Check 1st trip DTC.

Is 1st trip DTC detected?

- YES >> Go to [EC-186, "Diagnosis Procedure"](#).
NO >> INSPECTION END

Diagnosis Procedure

INFOID:000000005151735

1.CHECK GROUND CONNECTIONS

1. Turn ignition switch OFF.
2. Check ground connection M95. Refer to Ground Inspection in [GI-39, "Circuit Inspection"](#).

Is the inspection result normal?

- OK >> GO TO 2.
NG >> Repair or replace ground connections.

2.CHECK ENGINE COOLANT TEMPERATURE SENSOR

Refer to [EC-186, "Component Inspection"](#).

Is the inspection result normal?

- OK >> GO TO 3.
NG >> Replace engine coolant temperature sensor.

3.CHECK INTERMITTENT INCIDENT

Refer to [GI-36, "Intermittent Incident"](#).

>> **INSPECTION END**

Component Inspection

INFOID:000000005151736

1.CHECK ENGINE COOLANT TEMPERATURE SENSOR

1. Turn ignition switch OFF.
2. Disconnect engine coolant temperature sensor harness connector.
3. Remove engine coolant temperature sensor.
4. Check resistance between engine coolant temperature sensor terminals by heating with hot water as shown in the figure.

Terminals	Condition	Resistance (kΩ)	
1 and 2	Temperature [°C (°F)]	20 (68)	2.37 - 2.63
		50 (122)	0.68 - 1.00
		90 (194)	0.236 - 0.260

Is the inspection result normal?

- YES >> INSPECTION END
NO >> Replace engine coolant temperature sensor.

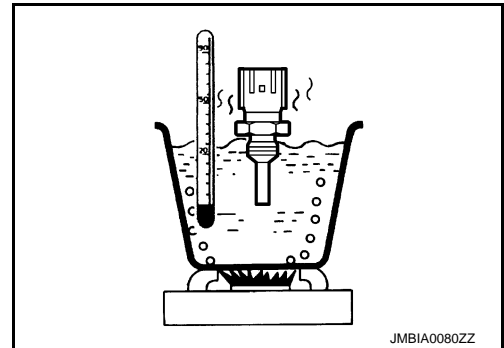

P0117, P0118 ECT SENSOR

[VQ37VHR]

< DTC/CIRCUIT DIAGNOSIS >

P0117, P0118 ECT SENSOR

Description

INFOID:000000005151737

The engine coolant temperature sensor is used to detect the engine coolant temperature. The sensor modifies a voltage signal from the ECM. The modified signal returns to the ECM as the engine coolant temperature input. The sensor uses a thermistor which is sensitive to the change in temperature. The electrical resistance of the thermistor decreases as temperature increases.

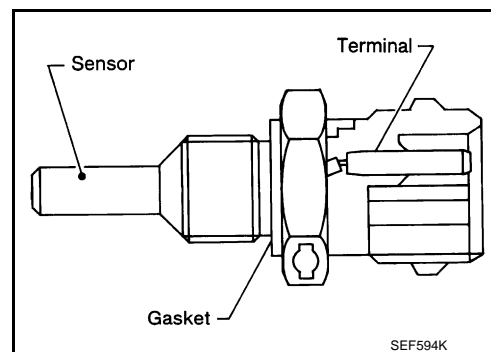

<Reference data>

Engine coolant temperature [°C (°F)]	Voltage* (V)	Resistance (kΩ)
-10 (14)	4.4	7.0 - 11.4
20 (68)	3.5	2.37 - 2.63
50 (122)	2.2	0.68 - 1.00
90 (194)	0.9	0.236 - 0.260

*: These data are reference values and are measured between ECM terminals 71 (Engine coolant temperature sensor) and 84 (Sensor ground).

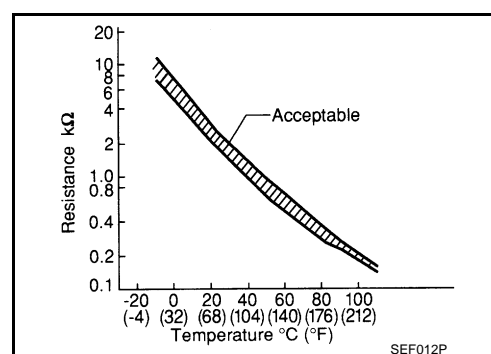

DTC Logic

INFOID:000000005151738

DTC DETECTION LOGIC

DTC No.	Trouble Diagnosis Name	DTC Detecting Condition	Possible Cause
P0117	Engine coolant temperature sensor circuit low input	An excessively low voltage from the sensor is sent to ECM.	<ul style="list-style-type: none"> Harness or connectors (The sensor circuit is open or shorted.) Engine coolant temperature sensor
P0118	Engine coolant temperature sensor circuit high input	An excessively high voltage from the sensor is sent to ECM.	

DTC CONFIRMATION PROCEDURE

1. PRECONDITIONING

If DTC Confirmation Procedure has been previously conducted, always perform the following procedure before conducting the next test.

- Turn ignition switch OFF and wait at least 10 seconds.
- Turn ignition switch ON.
- Turn ignition switch OFF and wait at least 10 seconds.

>> GO TO 2.

2. PERFORM DTC CONFIRMATION PROCEDURE

- Turn ignition switch ON and wait at least 5 seconds.
- Check DTC.

Is DTC detected?

- YES >> Go to [EC-188, "Diagnosis Procedure"](#).
- NO >> INSPECTION END

P0117, P0118 ECT SENSOR

[VQ37VHR]

< DTC/CIRCUIT DIAGNOSIS >

Diagnosis Procedure

INFOID:000000005151739

1. CHECK GROUND CONNECTION

1. Turn ignition switch OFF.
2. Check ground connection M95. Refer to Ground Inspection in [GI-39. "Circuit Inspection"](#).

Is the inspection result normal?

- YES >> GO TO 2.
NO >> Repair or replace ground connection.

2. CHECK ECT SENSOR POWER SUPPLY CIRCUIT

1. Disconnect engine coolant temperature (ECT) sensor harness connector.
2. Turn ignition switch ON.
3. Check the voltage between ECT sensor harness connector and ground.

ECT sensor		Ground	Voltage (V)
Connector	Terminal		
F17	1	Ground	Approx. 5

Is the inspection result normal?

- YES >> GO TO 3.
NO >> Repair open circuit, short to ground or short to power in harness or connectors.

3. CHECK ECT SENSOR GROUND CIRCUIT FOR OPEN AND SHORT

1. Turn ignition switch OFF.
2. Disconnect ECM harness connector.
3. Check the continuity between ECT sensor harness connector and ECM harness connector.

ECT sensor		ECM		Continuity
Connector	Terminal	Connector	Terminal	
F17	2	F102	84	Existed

4. Also check harness for short to ground and short to power.

Is the inspection result normal?

- YES >> GO TO 4.
NO >> Repair open circuit, short to ground or short to power in harness or connectors.

4. CHECK ENGINE COOLANT TEMPERATURE SENSOR

Refer to [EC-188. "Component Inspection"](#).

Is the inspection result normal?

- YES >> GO TO 5.
NO >> Replace engine coolant temperature sensor.

5. CHECK INTERMITTENT INCIDENT

Refer to [GI-36. "Intermittent Incident"](#).

>> INSPECTION END

Component Inspection

INFOID:000000005151740

1. CHECK ENGINE COOLANT TEMPERATURE SENSOR

1. Turn ignition switch OFF.
2. Disconnect engine coolant temperature sensor harness connector.
3. Remove engine coolant temperature sensor.

P0117, P0118 ECT SENSOR

[VQ37VHR]

< DTC/CIRCUIT DIAGNOSIS >

4. Check resistance between engine coolant temperature sensor terminals by heating with hot water as shown in the figure.

Terminals	Condition	Resistance (k Ω)	
1 and 2	Temperature [$^{\circ}$ C ($^{\circ}$ F)]	20 (68)	2.37 - 2.63
		50 (122)	0.68 - 1.00
		90 (194)	0.236 - 0.260

Is the inspection result normal?

YES >> INSPECTION END

NO >> Replace engine coolant temperature sensor.

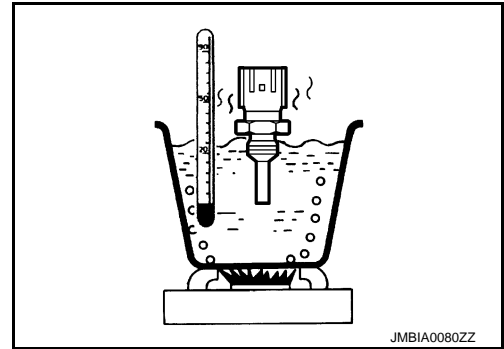

A

EC

C

D

E

F

G

H

I

J

K

L

M

N

O

P

P0122, P0123, P0227, P0228 TP SENSOR

< DTC/CIRCUIT DIAGNOSIS >

[VQ37VHR]

P0122, P0123, P0227, P0228 TP SENSOR

Description

INFOID:000000005151741

Electric throttle control actuator consists of throttle control motor, throttle position sensor, etc. The throttle position sensor responds to the throttle valve movement.

The throttle position sensor has two sensors. These sensors are a kind of potentiometer which transform the throttle valve position into output voltage, and emit the voltage signals to the ECM. The ECM judges the current opening angle of the throttle valve from these signals and controls throttle valve opening angle in response to driving conditions via the throttle control motor.

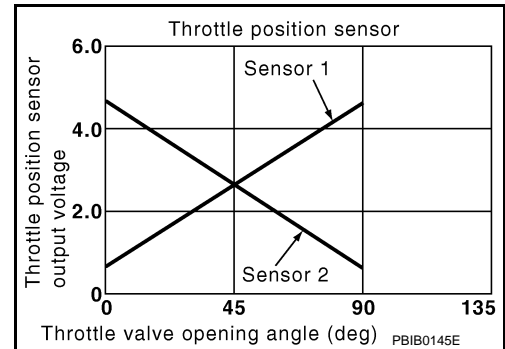

DTC Logic

INFOID:000000005151742

DTC DETECTION LOGIC

NOTE:

If DTC P0122, P0123, P0227 or P0228 is displayed with DTC P0643, first perform the trouble diagnosis for DTC P0643. Refer to [EC-364, "DTC Logic"](#).

DTC No.	Trouble diagnosis name	DTC detecting condition	Possible cause
P0122	Throttle position sensor 2 (bank 1) circuit low input	An excessively low voltage from the TP sensor 2 is sent to ECM.	<ul style="list-style-type: none"> • Harness or connectors (TP sensor 2 circuit is open or shorted.) • Electric throttle control actuator (TP sensor 2)
P0123	Throttle position sensor 2 (bank 1) circuit high input	An excessively high voltage from the TP sensor 2 is sent to ECM.	
P0227	Throttle position sensor 2 (bank 2) circuit low input	An excessively low voltage from the TP sensor 2 is sent to ECM.	
P0228	Throttle position sensor 2 (bank 2) circuit high input	An excessively high voltage from the TP sensor 2 is sent to ECM.	

DTC CONFIRMATION PROCEDURE

1. PRECONDITIONING

If DTC Confirmation Procedure has been previously conducted, always perform the following procedure before conducting the next test.

1. Turn ignition switch OFF and wait at least 10 seconds.
2. Turn ignition switch ON.
3. Turn ignition switch OFF and wait at least 10 seconds.

TESTING CONDITION:

Before performing the following procedure, confirm that battery voltage is more than 10 V at idle.

>> GO TO 2.

2. PERFORM DTC CONFIRMATION PROCEDURE

1. Start engine and let it idle for 1 second.
2. Check DTC.

Is DTC detected?

- YES >> Go to [EC-191, "Diagnosis Procedure"](#).
 NO >> INSPECTION END

P0122, P0123, P0227, P0228 TP SENSOR

< DTC/CIRCUIT DIAGNOSIS >

[VQ37VHR]

Diagnosis Procedure

INFOID:000000005151743

1. CHECK GROUND CONNECTION

1. Turn ignition switch OFF.
2. Check ground connection M95. Refer to Ground Inspection in [GI-39. "Circuit Inspection"](#).

Is the inspection result normal?

- YES >> GO TO 2.
NO >> Repair or replace ground connection.

2. CHECK THROTTLE POSITION SENSOR 2 POWER SUPPLY CIRCUIT

1. Disconnect electric throttle control actuator harness connector.
2. Turn ignition switch ON.
3. Check the voltage between electric throttle control actuator harness connector and ground.

DTC	Electric throttle control actuator			Ground	Voltage (V)
	Bank	Connector	Terminal		
P0122, P0123	1	F6	6	Ground	Approx. 5
P0227, P0228	2	F27	1		

Is the inspection result normal?

- YES >> GO TO 3.
NO >> Repair open circuit, short to ground or short to power in harness or connectors.

3. CHECK THROTTLE POSITION SENSOR 2 GROUND CIRCUIT FOR OPEN AND SHORT

1. Turn ignition switch OFF.
2. Disconnect ECM harness connector.
3. Check the continuity between electric throttle control actuator harness connector and ECM harness connector.

DTC	Electric throttle control actuator			ECM		Continuity
	Bank	Connector	Terminal	Connector	Terminal	
P0122, P0123	1	F6	3	F101	40	Existed
P0227, P0228	2	F27	4		48	

4. Also check harness for short to ground and short to power.

Is the inspection result normal?

- YES >> GO TO 4.
NO >> Repair open circuit, short to ground or short to power in harness or connectors.

4. CHECK THROTTLE POSITION SENSOR 2 INPUT SIGNAL CIRCUIT FOR OPEN AND SHORT

1. Check the continuity between electric throttle control actuator harness connector and ECM harness connector.

DTC	Electric throttle control actuator			ECM		Continuity
	Bank	Connector	Terminal	Connector	Terminal	
P0122, P0123	1	F6	5	F101	34	Existed
P0227, P0228	2	F27	3		35	

2. Also check harness for short to ground and short to power.

Is the inspection result normal?

- YES >> GO TO 5.
NO >> Repair open circuit, short to ground or short to power in harness or connectors.

5. CHECK THROTTLE POSITION SENSOR

Refer to [EC-192. "Component Inspection"](#).

P0122, P0123, P0227, P0228 TP SENSOR

[VQ37VHR]

< DTC/CIRCUIT DIAGNOSIS >

Is the inspection result normal?

- YES >> GO TO 7.
- NO >> GO TO 6.

6.REPLACE ELECTRIC THROTTLE CONTROL ACTUATOR

1. Replace malfunctioning electric throttle control actuator.
2. Go to [EC-192, "Special Repair Requirement"](#).

>> INSPECTION END

7.CHECK INTERMITTENT INCIDENT

Refer to [GI-36, "Intermittent Incident"](#).

>> INSPECTION END

Component Inspection

INFOID:000000005151744

1.CHECK THROTTLE POSITION SENSOR

1. Turn ignition switch OFF.
2. Reconnect all harness connectors disconnected.
3. Perform [EC-18, "THROTTLE VALVE CLOSED POSITION LEARNING : Special Repair Requirement"](#).
4. Turn ignition switch ON.
5. Set selector lever to D (A/T) or 1st (M/T) position.
6. Check the voltage between ECM harness connector terminals under the following conditions.

ECM			Condition	Voltage (V)
Connector	+	-		
	Terminal	Terminal		
F101	30 [TP sensor 1 (bank 1)]	40	Fully released	More than 0.36
			Fully depressed	Less than 4.75
	31 [TP sensor 1 (bank 2)]	48	Fully released	More than 0.36
			Fully depressed	Less than 4.75
	34 [TP sensor 2 (bank 1)]	40	Fully released	Less than 4.75
			Fully depressed	More than 0.36
	35 [TP sensor 2 (bank 2)]	48	Fully released	Less than 4.75
			Fully depressed	More than 0.36

Is the inspection result normal?

- YES >> INSPECTION END
- NO >> GO TO 2.

2.REPLACE ELECTRIC THROTTLE CONTROL ACTUATOR

1. Replace malfunctioning electric throttle control actuator.
2. Go to [EC-192, "Special Repair Requirement"](#).

>> INSPECTION END

Special Repair Requirement

INFOID:000000005151745

1.PERFORM THROTTLE VALVE CLOSED POSITION LEARNING

Refer to [EC-18, "THROTTLE VALVE CLOSED POSITION LEARNING : Special Repair Requirement"](#)

>> GO TO 2.

2.PERFORM IDLE AIR VOLUME LEARNING

P0122, P0123, P0227, P0228 TP SENSOR

< DTC/CIRCUIT DIAGNOSIS >

[VQ37VHR]

Refer to [EC-19. "IDLE AIR VOLUME LEARNING : Special Repair Requirement"](#)

>> END

A

EC

C

D

E

F

G

H

I

J

K

L

M

N

O

P

P0125 ECT SENSOR

Description

INFOID:000000005151746

The engine coolant temperature sensor is used to detect the engine coolant temperature. The sensor modifies a voltage signal from the ECM. The modified signal returns to the ECM as the engine coolant temperature input. The sensor uses a thermistor which is sensitive to the change in temperature. The electrical resistance of the thermistor decreases as temperature increases.

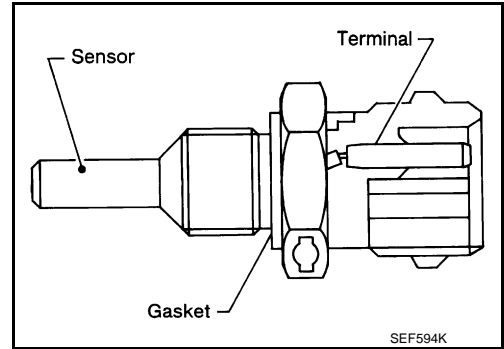

<Reference data>

Engine coolant temperature [°C (°F)]	Voltage* (V)	Resistance (kΩ)
-10 (14)	4.4	7.0 - 11.4
20 (68)	3.5	2.37 - 2.63
50 (122)	2.2	0.68 - 1.00
90 (194)	0.9	0.236 - 0.260

*: These data are reference values and are measured between ECM terminals 71 (Engine coolant temperature sensor) and 84 (Sensor ground).

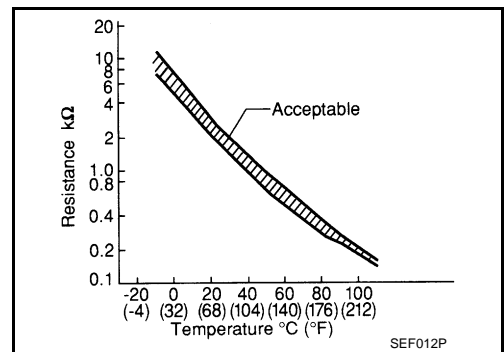

DTC Logic

INFOID:000000005151747

DTC DETECTION LOGIC

NOTE:

If DTC P0125 is displayed with P0117 or P0118, first perform the trouble diagnosis for DTC P0117 or P0118. Refer to [EC-187. "DTC Logic"](#).

DTC No.	Trouble diagnosis name	DTC detecting condition	Possible cause
P0125	Insufficient engine coolant temperature for closed loop fuel control	<ul style="list-style-type: none"> Voltage sent to ECM from the sensor is not practical, even when some time has passed after starting the engine. Engine coolant temperature is insufficient for closed loop fuel control. 	<ul style="list-style-type: none"> Harness or connectors (High resistance in the circuit) Engine coolant temperature sensor Thermostat

DTC CONFIRMATION PROCEDURE

1. PRECONDITIONING

If DTC Confirmation Procedure has been previously conducted, always perform the following procedure before conducting the next test.

1. Turn ignition switch OFF and wait at least 10 seconds.
2. Turn ignition switch ON.
3. Turn ignition switch OFF and wait at least 10 seconds.

>> GO TO 2.

2. CHECK ENGINE COOLANT TEMPERATURE SENSOR FUNCTION

1. Turn ignition switch ON.
2. Select "DATA MONITOR" mode with CONSULT-III.
3. Check that "COOLAN TEMP/S" is above 10°C (50°F).

Is the temperature above 10°C (50°F)?

P0125 ECT SENSOR

[VQ37VHR]

< DTC/CIRCUIT DIAGNOSIS >

- YES >> INSPECTION END
NO >> GO TO 3.

3.PERFORM DTC CONFIRMATION PROCEDURE

1. Start engine and run it for 65 minutes at idle speed.
If "COOLAN TEMP/S" increases to more than 10°C (50°F) within 65 minutes, stop engine because the test result will be OK.

CAUTION:

Be careful not to overheat engine.

2. Check 1st trip DTC.

Is 1st trip DTC detected?

- YES >> [EC-195. "Diagnosis Procedure"](#)
NO >> INSPECTION END

Diagnosis Procedure

INFOID:000000005151748

1.CHECK GROUND CONNECTION

1. Turn ignition switch OFF.
2. Check ground connection M95. Refer to Ground Inspection in [GI-39. "Circuit Inspection"](#).

Is the inspection result normal?

- YES >> GO TO 2.
NO >> Repair or replace ground connection.

2.CHECK ENGINE COOLANT TEMPERATURE SENSOR

Refer to [EC-195. "Component Inspection"](#).

Is the inspection result normal?

- YES >> GO TO 3.
NO >> Replace engine coolant temperature sensor.

3.CHECK THERMOSTAT OPERATION

When the engine is cold [lower than 70°C (158°F)] condition, grasp lower radiator hose and confirm the engine coolant does not flow.

Is the inspection result normal?

- YES >> GO TO 4.
NO >> Repair or replace thermostat. Refer to [CO-20. "Removal and Installation"](#).

4.CHECK INTERMITTENT INCIDENT

Refer to [GI-36. "Intermittent Incident"](#).

>> INSPECTION END

Component Inspection

INFOID:000000005151749

1.CHECK ENGINE COOLANT TEMPERATURE SENSOR

1. Turn ignition switch OFF.
2. Disconnect engine coolant temperature sensor harness connector.
3. Remove engine coolant temperature sensor.

P0125 ECT SENSOR

[VQ37VHR]

< DTC/CIRCUIT DIAGNOSIS >

4. Check resistance between engine coolant temperature sensor terminals by heating with hot water as shown in the figure.

Terminals	Condition	Resistance (k Ω)	
1 and 2	Temperature [$^{\circ}$ C ($^{\circ}$ F)]	20 (68)	2.37 - 2.63
		50 (122)	0.68 - 1.00
		90 (194)	0.236 - 0.260

Is the inspection result normal?

YES >> INSPECTION END

NO >> Replace engine coolant temperature sensor.

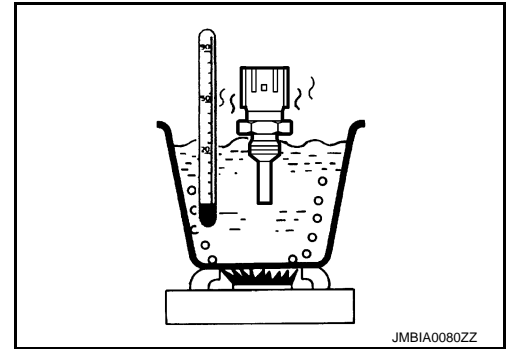

P0127 IAT SENSOR

< DTC/CIRCUIT DIAGNOSIS >

[VQ37VHR]

P0127 IAT SENSOR

Description

INFOID:000000005151750

The intake air temperature sensor is built-into mass air flow sensor (bank 1) (1). The sensor detects intake air temperature and transmits a signal to the ECM.

The temperature sensing unit uses a thermistor which is sensitive to the change in temperature. Electrical resistance of the thermistor decreases in response to the temperature rise.

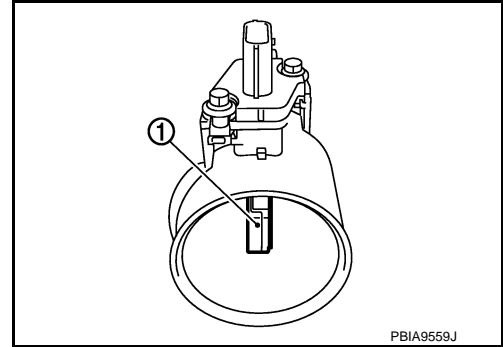

<Reference data>

Intake air temperature [°C (°F)]	Voltage* (V)	Resistance (kΩ)
25 (77)	3.3	1.800 - 2.200
80 (176)	1.2	0.283 - 0.359

*: These data are reference values and are measured between ECM terminals 67 (Intake air temperature sensor) and 68 (Sensor ground).

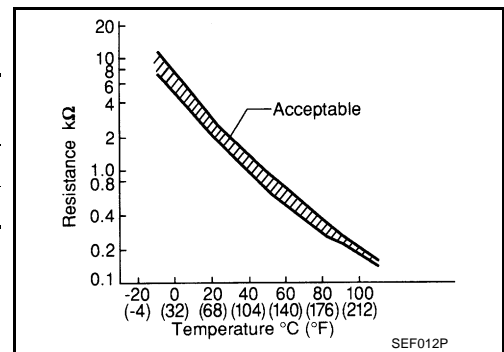

DTC Logic

INFOID:000000005151751

DTC DETECTION LOGIC

DTC No.	Trouble diagnosis name	DTC detecting condition	Possible cause
P0127	Intake air temperature too high	Rationally incorrect voltage from the sensor is sent to ECM, compared with the voltage signal from engine coolant temperature sensor.	<ul style="list-style-type: none"> • Harness or connectors (The sensor circuit is open or shorted) • Intake air temperature sensor

DTC CONFIRMATION PROCEDURE

1. PRECONDITIONING

If DTC Confirmation Procedure has been previously conducted, always perform the following procedure before conducting the next test.

1. Turn ignition switch OFF and wait at least 10 seconds.
2. Turn ignition switch ON.
3. Turn ignition switch OFF and wait at least 10 seconds.

TESTING CONDITION:

This test may be conducted with the drive wheels lifted in the shop or by driving the vehicle. If a road test is expected to be easier, it is unnecessary to lift the vehicle.

>> GO TO 2.

2. PERFORM DTC CONFIRMATION PROCEDURE

1. Wait until engine coolant temperature is less than 90°C (194°F)
 - Turn ignition switch ON.
 - Select "DATA MONITOR" mode with CONSULT-III.
 - Check the engine coolant temperature.
 - If the engine coolant temperature is not less than 90°C (194°F), turn ignition switch OFF and cool down engine.

P0127 IAT SENSOR

[VQ37VHR]

< DTC/CIRCUIT DIAGNOSIS >

NOTE:

- Perform the following steps before engine coolant temperature is above 90°C (194°F).
- Turn ignition switch ON.
- Select "DATA MONITOR" mode with CONSULT-III.
- Start engine.
- Hold vehicle speed at more than 70 km/h (43 MPH) for 100 consecutive seconds.

CAUTION:

Always drive vehicle at a safe speed.

- Check 1st trip DTC.

Is 1st trip DTC detected?

- YES >> Go to [EC-198, "Diagnosis Procedure"](#).
NO >> INSPECTION END

Diagnosis Procedure

INFOID:000000005151752

1.CHECK GROUND CONNECTION

- Turn ignition switch OFF.
- Check ground connection M95. Refer to Ground Inspection in [GI-39, "Circuit Inspection"](#).

Is the inspection result normal?

- YES >> GO TO 2.
NO >> Repair or replace ground connection.

2.CHECK INTAKE AIR TEMPERATURE SENSOR

Refer to [EC-198, "Component Inspection"](#).

Is the inspection result normal?

- YES >> GO TO 3.
NO >> Replace mass air flow sensor (bank 1) (with intake air temperature sensor).

3.CHECK INTERMITTENT INCIDENT

Refer to [GI-36, "Intermittent Incident"](#).

>> INSPECTION END

Component Inspection

INFOID:000000005151753

1.CHECK INTAKE AIR TEMPERATURE SENSOR

- Turn ignition switch OFF.
- Disconnect mass air flow sensor (bank 1) harness connector.
- Check resistance between mass air flow sensor (bank 1) terminals as follows.

Terminals	Condition	Resistance (kΩ)
1 and 2	Temperature [°C (°F)] 25 (77)	1.800 - 2.200

Is the inspection result normal?

- YES >> INSPECTION END
NO >> Replace mass air flow sensor (bank 1) (with intake air temperature sensor).

P0128 THERMOSTAT FUNCTION

< DTC/CIRCUIT DIAGNOSIS >

[VQ37VHR]

P0128 THERMOSTAT FUNCTION

DTC Logic

INFOID:000000005151754

DTC DETECTION LOGIC

NOTE:

If DTC P0128 is displayed with DTC P0300, P0301, P0302, P0303, P0304, P0305 or P0306, first perform the trouble diagnosis for P0300, P0301, P0302, P0303, P0304, P0305, P0306. Refer to [EC-260](#).

Engine coolant temperature has not risen enough to open the thermostat even though the engine has run long enough.

This is due to a leak in the seal or the thermostat being stuck open.

DTC No.	Trouble diagnosis name	DTC detecting condition	Possible cause
P0128	Thermostat function	The engine coolant temperature does not reach to specified temperature even though the engine has run long enough.	<ul style="list-style-type: none">ThermostatLeakage from sealing portion of thermostatEngine coolant temperature sensor

DTC CONFIRMATION PROCEDURE

1. PRECONDITIONING

If DTC Confirmation Procedure has been previously conducted, always perform the following before conducting the next test.

- Turn ignition switch OFF and wait at least 10 seconds.
- Turn ignition switch ON.
- Turn ignition switch OFF and wait at least 10 seconds.

TESTING CONDITION:

- For best results, perform at ambient temperature of -10°C (14°F) or higher.
- For best results, perform at engine coolant temperature of -10°C (14°F) to 56°C (133°F).
- Before performing the following procedure, do not add fuel.

>> GO TO 2.

2. PERFORM DTC CONFIRMATION PROCEDURE

- Turn A/C switch OFF.
- Turn blower fan switch OFF.
- Turn ignition switch ON.
- Select "COOLAN TEMP/S" in "DATA MONITOR" mode with CONSULT-III.
- Check the indication of "COOLAN TEMP/S".
If it is below 56°C (133°F), go to the next steps.
If it is above 56°C (133°F), cool engine down to less than 56°C (133°F). Then go to next step.
- Start engine.
- Drive vehicle for 10 consecutive minutes under the following condition.

VHCL SPEED SE	More than 56 km/h (35 mph)
---------------	----------------------------

If "COOLAN TEMP/S" increases to more than 75°C (167°F) within 10 minutes, turn ignition switch OFF because the test result will be OK.

CAUTION:

Always drive vehicle at safe speed.

- Check 1st trip DTC.

Is 1st trip DTC detected?

- YES >> Go to [EC-199, "Diagnosis Procedure"](#).
NO >> INSPECTION END

Diagnosis Procedure

INFOID:000000005151755

1. CHECK ENGINE COOLANT TEMPERATURE SENSOR

Refer to [EC-200, "Component Inspection"](#).

P0128 THERMOSTAT FUNCTION

[VQ37VHR]

< DTC/CIRCUIT DIAGNOSIS >

Is the inspection result normal?

YES >> GO TO 2.

NO >> Replace engine coolant temperature sensor.

2. CHECK THERMOSTAT

Check thermostat. Refer to [CO-20. "Inspection"](#).

Is the inspection result normal?

YES >> INSPECTION END

NO >> Replace thermostat.

Component Inspection

INFOID:000000005151756

1. CHECK ENGINE COOLANT TEMPERATURE SENSOR

1. Turn ignition switch OFF.
2. Disconnect engine coolant temperature sensor harness connector.
3. Remove engine coolant temperature sensor.
4. Check resistance between engine coolant temperature sensor terminals by heating with hot water as shown in the figure.

Terminals	Condition	Resistance (k Ω)	
1 and 2	Temperature [$^{\circ}$ C ($^{\circ}$ F)]	20 (68)	2.37 - 2.63
		50 (122)	0.68 - 1.00
		90 (194)	0.236 - 0.260

Is the inspection result normal?

YES >> INSPECTION END

NO >> Replace engine coolant temperature sensor.

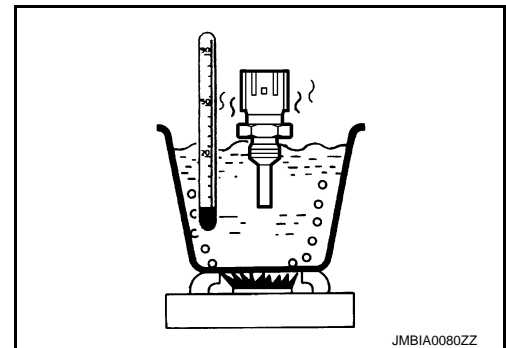

P0130, P0150 A/F SENSOR 1

< DTC/CIRCUIT DIAGNOSIS >

[VQ37VHR]

P0130, P0150 A/F SENSOR 1

Description

INFOID:000000005151757

The air fuel ratio (A/F) sensor 1 is a planar one-cell limit current sensor. The sensor element of the A/F sensor 1 is composed an electrode layer, which transports ions. It has a heater in the element. The sensor is capable of precise measurement $\lambda = 1$, but also in the lean and rich range. Together with its control electronics, the sensor outputs a clear, continuous signal throughout a wide λ range. The exhaust gas components diffuse through the diffusion layer at the sensor cell. An electrode layer is applied voltage, and this current relative oxygen density in lean. Also this current relative hydrocarbon density in rich.

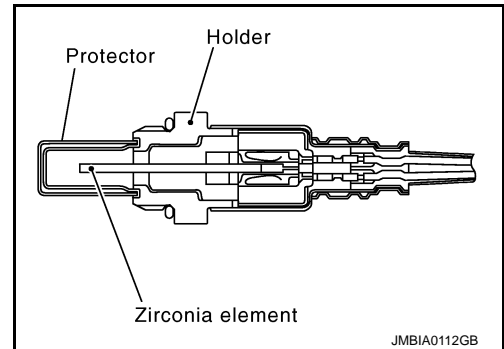

Therefore, the A/F sensor 1 is able to indicate air fuel ratio by this electrode layer of current. In addition, a heater is integrated in the sensor to ensure the required operating temperature of about 800°C (1,472°F).

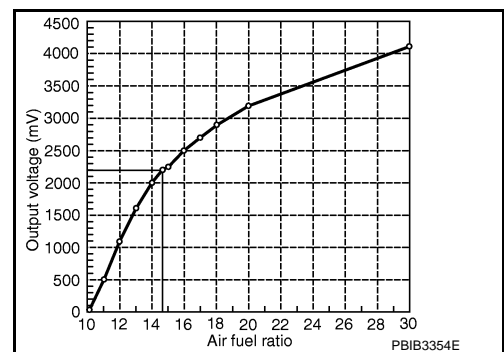

DTC Logic

INFOID:000000005151758

DTC DETECTION LOGIC

To judge malfunctions, the diagnosis checks that the A/F signal computed by ECM from the A/F sensor 1 signal fluctuates according to fuel feedback control.

DTC No.	Trouble diagnosis name	DTC detecting condition		Possible Cause
P0130	Air fuel ratio (A/F) sensor 1 (bank 1) circuit	A)	The A/F signal computed by ECM from the A/F sensor 1 signal is constantly in a range other than approx. 2.2 V.	<ul style="list-style-type: none"> • Harness or connectors (The A/F sensor 1 circuit is open or shorted.) • A/F sensor 1
		B)	The A/F signal computed by ECM from the A/F sensor 1 signal is constantly approx. 2.2 V.	
P0150	Air fuel ratio (A/F) sensor 1 (bank 2) circuit	A)	The A/F signal computed by ECM from the A/F sensor 1 signal is constantly in a range other than approx. 2.2 V.	
		B)	The A/F signal computed by ECM from the A/F sensor 1 signal is constantly approx. 2.2 V.	

DTC CONFIRMATION PROCEDURE

1. PRECONDITIONING

If DTC Confirmation Procedure has been previously conducted, always perform the following procedure before conducting the next test.

1. Turn ignition switch OFF and wait at least 10 seconds.
2. Turn ignition switch ON.
3. Turn ignition switch OFF and wait at least 10 seconds.

TESTING CONDITION:

Before performing the following procedure, confirm that battery voltage is more than 11 V at idle.

>> GO TO 2.

P0130, P0150 A/F SENSOR 1

[VQ37VHR]

< DTC/CIRCUIT DIAGNOSIS >

2. PERFORM DTC CONFIRMATION PROCEDURE FOR MALFUNCTION A

1. Start engine and warm it up to normal operating temperature.
2. Let engine idle for 2 minutes.
3. Check 1st trip DTC.

Is 1st trip DTC detected?

YES >> Go to [EC-203, "Diagnosis Procedure"](#).

NO-1 >> With CONSULT-III: GO TO 3.

NO-2 >> Without CONSULT-III: GO TO 7.

3. CHECK AIR FUEL RATIO (A/F) SENSOR 1 FUNCTION

1. Start engine and warm it up to normal operating temperature.
2. Select "A/F SEN1 (B1)" or "A/F SEN1 (B2)" in "DATA MONITOR" mode with CONSULT-III.
3. Check "A/F SEN1 (B1)" or "A/F SEN1 (B2)" indication.

Does the indication fluctuate around 2.2 V?

YES >> GO TO 4.

NO >> Go to [EC-203, "Diagnosis Procedure"](#).

4. PERFORM DTC CONFIRMATION PROCEDURE FOR MALFUNCTION B-I

1. Select "A/F SEN1 (B1) P1276" (for DTC P0130) or "A/F SEN1 (B2) P1286" (for DTC P0150) of "A/F SEN1" in "DTC WORK SUPPORT" mode with CONSULT-III.
2. Touch "START".
3. When the following conditions are met, "TESTING" will be displayed on the CONSULT-III screen.

ENG SPEED	1,100 - 3,200 rpm
VHCL SPEED SE	More than 64 km/h (40 mph)
B/FUEL SCHDL	1.0 - 8.0 msec
Selector lever	D position (A/T) 5th position (M/T)

If "TESTING" is not displayed after 20 seconds, retry from step 2.

CAUTION:

Always drive vehicle at a safe speed.

Is "TESTING" displayed on CONSULT-III screen?

YES >> GO TO 5.

NO >> Check A/F sensor 1 function again. GO TO 3.

5. PERFORM DTC CONFIRMATION PROCEDURE FOR MALFUNCTION B-II

Release accelerator pedal fully.

NOTE:

Never apply brake when releasing the accelerator pedal.

Which does "TESTING" change to?

COMPLETED>>GO TO 6.

OUT OF CONDITION>>Retry DTC CONFIRMATION PROCEDURE. GO TO 4.

6. PERFORM DTC CONFIRMATION PROCEDURE FOR MALFUNCTION B-III

Touch "SELF-DIAG RESULT".

Which is displayed on CONSULT-III screen?

OK >> INSPECTION END

NG >> Go to [EC-203, "Diagnosis Procedure"](#).

7. PERFORM COMPONENT FUNCTION CHECK FOR MALFUNCTION B

Perform component function check. Refer to [EC-203, "Component Function Check"](#).

NOTE:

Use component function check to check the overall function of the A/F sensor 1 circuit. During this check, a 1st trip DTC might not be confirmed.

Is the inspection result normal?

P0130, P0150 A/F SENSOR 1

[VQ37VHR]

< DTC/CIRCUIT DIAGNOSIS >

- YES >> INSPECTION END
- NO >> Go to [EC-203, "Diagnosis Procedure"](#).

A

Component Function Check

INFOID:000000005151759

1. PERFORM COMPONENT FUNCTION CHECK

EC

With GST

1. Start engine and warm it up to normal operating temperature.
2. Drive the vehicle at a speed of 80 km/h (50 MPH) for a few minutes in the suitable gear position.
3. Shift the selector lever to D position (A/T) or 5th position (M/T), then release the accelerator pedal fully until the vehicle speed decreases to 50 km/h (30 MPH).

C

CAUTION:

Always drive vehicle at a safe speed.

D

NOTE:

Never apply brake when releasing the accelerator pedal.

E

4. Repeat steps 2 and 3 for five times.
5. Stop the vehicle and turn ignition switch OFF.
6. Turn ignition switch ON.
7. Turn ignition switch OFF and wait at least 10 seconds.
8. Restart engine.
9. Repeat steps 2 and 3 for five times.
10. Stop the vehicle and connect GST to the vehicle.
11. Check 1st trip DTC.

F

G

Is 1st trip DTC detected?

- YES >> Go to [EC-203, "Diagnosis Procedure"](#).
- NO >> INSPECTION END

H

Diagnosis Procedure

INFOID:000000005151760

1. CHECK GROUND CONNECTION

I

1. Turn ignition switch OFF.
2. Check ground connection M95. Refer to Ground Inspection in [GI-39, "Circuit Inspection"](#).

J

Is the inspection result normal?

- YES >> GO TO 2.
- NO >> Repair or replace ground connection.

K

2. CHECK AIR FUEL RATIO (A/F) SENSOR 1 POWER SUPPLY CIRCUIT

1. Disconnect A/F sensor 1 harness connector.
2. Turn ignition switch ON.
3. Check the voltage between A/F sensor 1 harness connector and ground.

L

M

DTC	A/F sensor 1			Ground	Voltage
	Bank	Connector	Terminal		
P0130	1	F3	4	Ground	Battery voltage
P0150	2	F20	4		

N

Is the inspection result normal?

- YES >> GO TO 4.
- NO >> GO TO 3.

O

3. DETECT MALFUNCTIONING PART

P

Check the following.

- Harness connectors E3, F1
- IPDM E/R harness connector E7
- 15 A fuse (No. 46)
- Harness for open or short between A/F sensor 1 and fuse

>> Repair or replace harness or connectors.

P0130, P0150 A/F SENSOR 1

[VQ37VHR]

< DTC/CIRCUIT DIAGNOSIS >

4. CHECK A/F SENSOR 1 INPUT SIGNAL CIRCUIT FOR OPEN AND SHORT

1. Turn ignition switch OFF.
2. Disconnect ECM harness connector.
3. Check the continuity between A/F sensor 1 harness connector and ECM harness connector.

DTC	A/F sensor 1			ECM		Continuity
	Bank	Connector	Terminal	Connector	Terminal	
P0130	1	F3	1	F102	57	Existed
			2		61	
P0150	2	F20	1		65	
			2		66	

4. Check the continuity between A/F sensor 1 harness connector and ground, or ECM harness connector and ground.

DTC	A/F sensor 1			Ground	Continuity
	Bank	Connector	Terminal		
P0130	1	F3	1	Ground	Not existed
			2		
P0150	2	F20	1		
			2		

DTC	ECM			Ground	Continuity
	Bank	Connector	Terminal		
P0130	1	F102	57	Ground	Not existed
			61		
P0150	2		65		
			66		

5. Also check harness for short to power.

Is the inspection result normal?

YES >> GO TO 5.

NO >> Repair open circuit, short to ground or short to power in harness or connectors.

5. CHECK INTERMITTENT INCIDENT

Perform [GI-36, "Intermittent Incident"](#).

Is the inspection result normal?

YES >> GO TO 6.

NO >> Repair or replace.

6. REPLACE AIR FUEL RATIO (A/F) SENSOR 1

Replace malfunctioning air fuel ratio (A/F) sensor 1.

CAUTION:

- Discard any A/F sensor which has been dropped from a height of more than 0.5 m (19.7 in) onto a hard surface such as a concrete floor; use a new one.
- Before installing new A/F sensor, clean exhaust system threads using Oxygen Sensor Thread Cleaner [commercial service tool (J-43897-18 or J-43897-12)] and approved Anti-seize Lubricant (commercial service tool).

>> INSPECTION END

P0131, P0151 A/F SENSOR 1

Description

INFOID:000000005151761

The air fuel ratio (A/F) sensor 1 is a planar one-cell limit current sensor. The sensor element of the A/F sensor 1 is composed an electrode layer, which transports ions. It has a heater in the element. The sensor is capable of precise measurement $\lambda = 1$, but also in the lean and rich range. Together with its control electronics, the sensor outputs a clear, continuous signal throughout a wide λ range. The exhaust gas components diffuse through the diffusion layer at the sensor cell. An electrode layer is applied voltage, and this current relative oxygen density in lean. Also this current relative hydrocarbon density in rich.

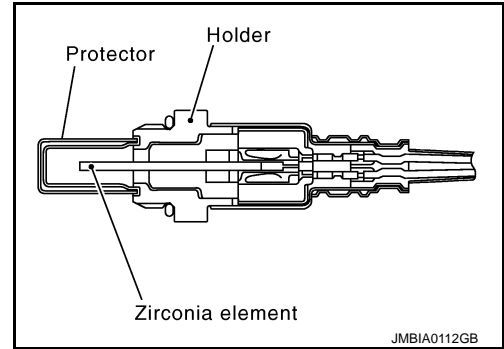

Therefore, the A/F sensor 1 is able to indicate air fuel ratio by this electrode layer of current. In addition, a heater is integrated in the sensor to ensure the required operating temperature of about 800°C (1,472°F).

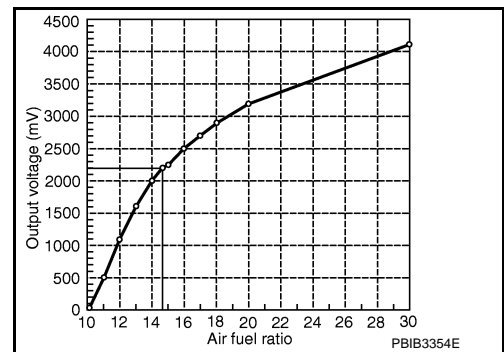

DTC Logic

INFOID:000000005151762

DTC DETECTION LOGIC

To judge malfunctions, the diagnosis checks that the A/F signal computed by ECM from the A/F sensor 1 signal is not inordinately low.

DTC No.	Trouble diagnosis name	DTC detecting condition	Possible Cause
P0131	Air fuel ratio (A/F) sensor 1 (bank 1) circuit low voltage	<ul style="list-style-type: none"> The A/F signal computed by ECM from the A/F sensor 1 signal is constantly approx. 0 V. 	<ul style="list-style-type: none"> Harness or connectors (The A/F sensor 1 circuit is open or shorted.) A/F sensor 1
P0151	Air fuel ratio (A/F) sensor 1 (bank 2) circuit low voltage		

DTC CONFIRMATION PROCEDURE

1. PRECONDITIONING

If DTC Confirmation Procedure has been previously conducted, always perform the following procedure before conducting the next test.

1. Turn ignition switch OFF and wait at least 10 seconds.
2. Turn ignition switch ON.
3. Turn ignition switch OFF and wait at least 10 seconds.

TESTING CONDITION:

Before performing the following procedure, confirm that battery voltage is more than 10.5 V at idle.

>> GO TO 2.

2. CHECK A/F SENSOR FUNCTION

1. Start engine and warm it up to normal operating temperature.
2. Select "A/F SEN1 (B1)" or "A/F SEN1 (B2)" in "DATA MONITOR" mode with CONSULT-III.
3. Check "A/F SEN1 (B1)" or "A/F SEN1 (B2)" indication.

Is the indication constantly approx. 0 V?

A
EC
C
D
E
F
G
H
I
J
K
L
M
N
O
P

P0131, P0151 A/F SENSOR 1

[VQ37VHR]

< DTC/CIRCUIT DIAGNOSIS >

- YES >> Go to [EC-206, "Diagnosis Procedure"](#).
NO >> GO TO 3.

3.PERFORM DTC CONFIRMATION PROCEDURE

1. Turn ignition switch OFF and wait at least 10 seconds.
2. Turn ignition switch ON.
3. Turn ignition switch OFF and wait at least 10 seconds.
4. Restart engine.
5. Drive and accelerate vehicle to more than 40 km/h (25 MPH) within 20 seconds after restarting engine.
CAUTION:
Always drive vehicle at a safe speed.
6. Maintain the following conditions for about 20 consecutive seconds.

ENG SPEED	1,000 - 3,200 rpm
VHCL SPEED SE	More than 40 km/h (25 mph)
B/FUEL SCHDL	1.5 - 9.0 msec
Selector lever	Suitable position

NOTE:

- Keep the accelerator pedal as steady as possible during cruising.
- If this procedure is not completed within 1 minute after restarting engine at step 4, return to step 1.

7. Check 1st trip DTC.

Is 1st trip DTC detected?

- YES >> Go to [EC-206, "Diagnosis Procedure"](#).
NO >> INSPECTION END

Diagnosis Procedure

INFOID:000000005151763

1.CHECK GROUND CONNECTION

1. Turn ignition switch OFF.
2. Check ground connection M95. Refer to Ground Inspection in [GI-39, "Circuit Inspection"](#).

Is the inspection result normal?

- YES >> GO TO 2.
NO >> Repair or replace ground connection.

2.CHECK AIR FUEL RATIO (A/F) SENSOR 1 POWER SUPPLY CIRCUIT

1. Disconnect A/F sensor 1 harness connector.
2. Turn ignition switch ON.
3. Check the voltage between A/F sensor 1 harness connector and ground.

DTC	A/F sensor 1			Ground	Voltage
	Bank	Connector	Terminal		
P0130	1	F3	4	Ground	Battery voltage
P0150	2	F20	4		

Is the inspection result normal?

- YES >> GO TO 4.
NO >> GO TO 3.

3.DETECT MALFUNCTIONING PART

Check the following.

- Harness connectors E3, F1
- IPDM E/R harness connector E7
- 15 A fuse (No. 46)
- Harness for open or short between A/F sensor 1 and fuse

P0131, P0151 A/F SENSOR 1

[VQ37VHR]

< DTC/CIRCUIT DIAGNOSIS >

>> Repair or replace harness or connectors.

4. CHECK A/F SENSOR 1 INPUT SIGNAL CIRCUIT FOR OPEN AND SHORT

1. Turn ignition switch OFF.
2. Disconnect ECM harness connector.
3. Check the continuity between A/F sensor 1 harness connector and ECM harness connector.

DTC	A/F sensor 1			ECM		Continuity
	Bank	Connector	Terminal	Connector	Terminal	
P0130	1	F3	1	F102	57	Existed
			2		61	
P0150	2	F20	1		65	
			2		66	

4. Check the continuity between A/F sensor 1 harness connector and ground, or ECM harness connector and ground.

DTC	A/F sensor 1			Ground	Continuity
	Bank	Connector	Terminal		
P0130	1	F3	1	Ground	Not existed
			2		
P0150	2	F20	1		
			2		

DTC	ECM			Ground	Continuity
	Bank	Connector	Terminal		
P0130	1	F102	57	Ground	Not existed
			61		
P0150	2		65		
			66		

5. Also check harness for short to power.

Is the inspection result normal?

YES >> GO TO 5.

NO >> Repair open circuit, short to ground or short to power in harness or connectors.

5. CHECK INTERMITTENT INCIDENT

Perform [GI-36. "Intermittent Incident"](#).

Is the inspection result normal?

YES >> GO TO 6.

NO >> Repair or replace.

6. REPLACE AIR FUEL RATIO (A/F) SENSOR 1

Replace malfunctioning air fuel ratio (A/F) sensor 1.

CAUTION:

- Discard any A/F sensor which has been dropped from a height of more than 0.5 m (19.7 in) onto a hard surface such as a concrete floor; use a new one.
- Before installing new A/F sensor, clean exhaust system threads using Oxygen Sensor Thread Cleaner [commercial service tool (J-43897-18 or J-43897-12)] and approved Anti-seize Lubricant (commercial service tool).

>> INSPECTION END

P0132, P0152 A/F SENSOR 1

Description

INFOID:000000005151764

The air fuel ratio (A/F) sensor 1 is a planar one-cell limit current sensor. The sensor element of the A/F sensor 1 is composed an electrode layer, which transports ions. It has a heater in the element. The sensor is capable of precise measurement $\lambda = 1$, but also in the lean and rich range. Together with its control electronics, the sensor outputs a clear, continuous signal throughout a wide λ range. The exhaust gas components diffuse through the diffusion layer at the sensor cell. An electrode layer is applied voltage, and this current relative oxygen density in lean. Also this current relative hydrocarbon density in rich.

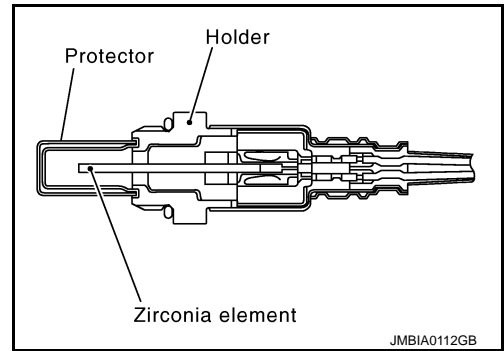

Therefore, the A/F sensor 1 is able to indicate air fuel ratio by this electrode layer of current. In addition, a heater is integrated in the sensor to ensure the required operating temperature of about 800°C (1,472°F).

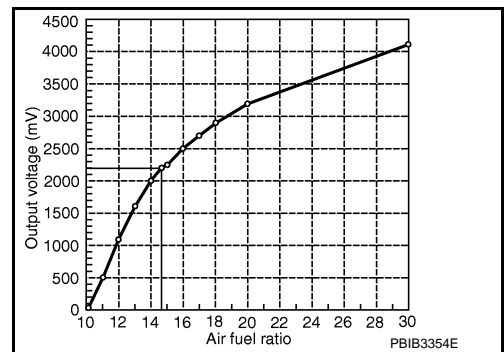

DTC Logic

INFOID:000000005151765

DTC DETECTION LOGIC

To judge the malfunction, the diagnosis checks that the A/F signal computed by ECM from the A/F sensor 1 signal is not inordinately high.

DTC No.	Trouble diagnosis name	DTC detecting condition	Possible Cause
P0132	Air fuel ratio (A/F) sensor 1 (bank 1) circuit high voltage	• The A/F signal computed by ECM from the A/F sensor 1 signal is constantly approx. 5 V.	<ul style="list-style-type: none"> • Harness or connectors (The A/F sensor 1 circuit is open or shorted.) • A/F sensor 1
P0152	Air fuel ratio (A/F) sensor 1 (bank 2) circuit high voltage		

DTC CONFIRMATION PROCEDURE

1. PRECONDITIONING

If DTC Confirmation Procedure has been previously conducted, always perform the following procedure before conducting the next test.

1. Turn ignition switch OFF and wait at least 10 seconds.
2. Turn ignition switch ON.
3. Turn ignition switch OFF and wait at least 10 seconds.

TESTING CONDITION:

Before performing the following procedure, confirm that battery voltage is more than 10.5 V at idle.

>> GO TO 2.

2. CHECK A/F SENSOR FUNCTION

1. Start engine and warm it up to normal operating temperature.
2. Select "A/F SEN1 (B1)" or "A/F SEN1 (B2)" in "DATA MONITOR" mode with CONSULT-III.
3. Check "A/F SEN1 (B1)" or "A/F SEN1 (B2)" indication.

Is the indication constantly approx. 5V?

P0132, P0152 A/F SENSOR 1

[VQ37VHR]

< DTC/CIRCUIT DIAGNOSIS >

- YES >> Go to [EC-209, "Diagnosis Procedure"](#).
NO >> GO TO 3.

3.PERFORM DTC CONFIRMATION PROCEDURE

1. Turn ignition switch OFF and wait at least 10 seconds.
2. Turn ignition switch ON.
3. Turn ignition switch OFF and wait at least 10 seconds.
4. Restart engine.
5. Drive and accelerate vehicle to more than 40 km/h (25 MPH) within 20 seconds after restarting engine.
CAUTION:
Always drive vehicle at a safe speed.
6. Maintain the following conditions for about 20 consecutive seconds.

ENG SPEED	1,000 - 3,200 rpm
VHCL SPEED SE	More than 40 km/h (25 mph)
B/FUEL SCHDL	1.5 - 9.0 msec
Selector lever	Suitable position

NOTE:

- Keep the accelerator pedal as steady as possible during cruising.
- If this procedure is not completed within 1 minute after restarting engine at step 4, return to step 1.

7. Check 1st trip DTC.

Is 1st trip DTC detected?

- YES >> Go to [EC-209, "Diagnosis Procedure"](#).
NO >> INSPECTION END

Diagnosis Procedure

INFOID:000000005151766

1.CHECK GROUND CONNECTION

1. Turn ignition switch OFF.
2. Check ground connection M95. Refer to Ground Inspection in [GI-39, "Circuit Inspection"](#).

Is the inspection result normal?

- YES >> GO TO 2.
NO >> Repair or replace ground connection.

2.CHECK AIR FUEL RATIO (A/F) SENSOR 1 POWER SUPPLY CIRCUIT

1. Disconnect A/F sensor 1 harness connector.
2. Turn ignition switch ON.
3. Check the voltage between A/F sensor 1 harness connector and ground.

DTC	A/F sensor 1			Ground	Voltage
	Bank	Connector	Terminal		
P0130	1	F3	4	Ground	Battery voltage
P0150	2	F20	4		

Is the inspection result normal?

- YES >> GO TO 4.
NO >> GO TO 3.

3.DETECT MALFUNCTIONING PART

Check the following.

- Harness connectors E3, F1
- IPDM E/R harness connector E7
- 15 A fuse (No. 46)
- Harness for open or short between A/F sensor 1 and fuse

P0132, P0152 A/F SENSOR 1

[VQ37VHR]

< DTC/CIRCUIT DIAGNOSIS >

>> Repair or replace harness or connectors.

4. CHECK A/F SENSOR 1 INPUT SIGNAL CIRCUIT FOR OPEN AND SHORT

1. Turn ignition switch OFF.
2. Disconnect ECM harness connector.
3. Check the continuity between A/F sensor 1 harness connector and ECM harness connector.

DTC	A/F sensor 1			ECM		Continuity
	Bank	Connector	Terminal	Connector	Terminal	
P0130	1	F3	1	F102	57	Existed
			2		61	
P0150	2	F20	1		65	
			2		66	

4. Check the continuity between A/F sensor 1 harness connector and ground, or ECM harness connector and ground.

DTC	A/F sensor 1			Ground	Continuity
	Bank	Connector	Terminal		
P0130	1	F3	1	Ground	Not existed
			2		
P0150	2	F20	1		
			2		

DTC	ECM			Ground	Continuity
	Bank	Connector	Terminal		
P0130	1	F102	57	Ground	Not existed
			61		
P0150	2		65		
			66		

5. Also check harness for short to power.

Is the inspection result normal?

YES >> GO TO 5.

NO >> Repair open circuit, short to ground or short to power in harness or connectors.

5. CHECK INTERMITTENT INCIDENT

Perform [GI-36. "Intermittent Incident"](#).

Is the inspection result normal?

YES >> GO TO 6.

NO >> Repair or replace.

6. REPLACE AIR FUEL RATIO (A/F) SENSOR 1

Replace malfunctioning air fuel ratio (A/F) sensor 1.

CAUTION:

- Discard any A/F sensor which has been dropped from a height of more than 0.5 m (19.7 in) onto a hard surface such as a concrete floor; use a new one.
- Before installing new A/F sensor, clean exhaust system threads using Oxygen Sensor Thread Cleaner [commercial service tool (J-43897-18 or J-43897-12)] and approved Anti-seize Lubricant (commercial service tool).

>> INSPECTION END

P0133, P0153 A/F SENSOR 1

Description

INFOID:000000005151767

The air fuel ratio (A/F) sensor 1 is a planar one-cell limit current sensor. The sensor element of the A/F sensor 1 is composed an electrode layer, which transports ions. It has a heater in the element. The sensor is capable of precise measurement $\lambda = 1$, but also in the lean and rich range. Together with its control electronics, the sensor outputs a clear, continuous signal throughout a wide λ range. The exhaust gas components diffuse through the diffusion layer at the sensor cell. An electrode layer is applied voltage, and this current relative oxygen density in lean. Also this current relative hydrocarbon density in rich.

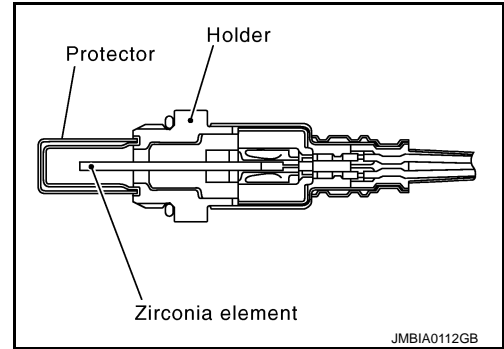

Therefore, the A/F sensor 1 is able to indicate air fuel ratio by this electrode layer of current. In addition, a heater is integrated in the sensor to ensure the required operating temperature of about 800°C (1,472°F).

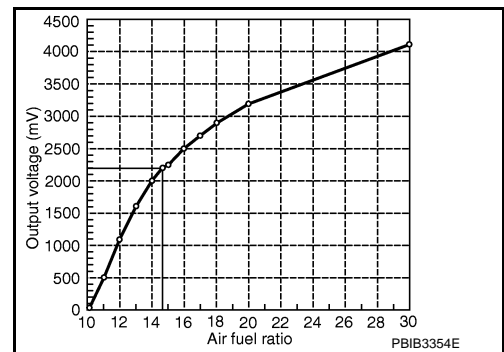

DTC Logic

INFOID:000000005151768

DTC DETECTION LOGIC

To judge malfunctions, this diagnosis measures response time of the A/F signal computed by ECM from the A/F sensor 1 signal. The time is compensated by engine operating (speed and load), fuel feedback control constant, and the A/F sensor 1 temperature index. Judgment is based on whether the compensated time (the A/F signal cycling time index) is inordinately long or not.

DTC No.	Trouble diagnosis name	DTC detecting condition	Possible Cause
P0133	Air fuel ratio (A/F) sensor 1 (bank 1) circuit slow response	<ul style="list-style-type: none"> The response of the A/F signal computed by ECM from A/F sensor 1 signal takes more than the specified time. 	<ul style="list-style-type: none"> Harness or connectors (The A/F sensor 1 circuit is open or shorted.) A/F sensor 1 A/F sensor 1 heater Fuel pressure Fuel injector Intake air leaks Exhaust gas leaks PCV Mass air flow sensor
P0153	Air fuel ratio (A/F) sensor 1 (bank 2) circuit slow response		

DTC CONFIRMATION PROCEDURE

1. PRECONDITIONING

If DTC Confirmation Procedure has been previously conducted, always perform the following procedure before conducting the next test.

1. Turn ignition switch OFF and wait at least 10 seconds.
2. Turn ignition switch ON.
3. Turn ignition switch OFF and wait at least 10 seconds.

TESTING CONDITION:

Before performing the following procedure, confirm that battery voltage is more than 11 V at idle.

Do you have CONSULT-III?

< DTC/CIRCUIT DIAGNOSIS >

- YES >> GO TO 2.
NO >> GO TO 5.

2.PERFORM DTC CONFIRMATION PROCEDURE-I

With CONSULT-III

1. Start engine and warm it up to normal operating temperature.
2. Turn ignition switch OFF and wait at least 10 seconds.
3. Turn ignition switch ON.
4. Turn ignition switch OFF and wait at least 10 seconds.
5. Start engine and keep the engine speed between 3,500 and 4,000 rpm for at least 1 minute under no load.
6. Let engine idle for 1 minute.
7. Select "A/F SEN1(B1) P1278/P1279" (for DTC P0133) or "A/F SEN1(B2) P1288/P1289" (for DTC P0153) of "A/F SEN1" in "DTC WORK SUPPORT" mode with CONSULT-III.
8. Touch "START".

Is "COMPLETED" displayed on CONSULT-III screen?

- YES >> GO TO 3
NO >> GO TO 4.

3.PERFORM DTC CONFIRMATION PROCEDURE-II

Touch "SELF-DIAG RESULT".

Which is displayed on CONSULT-III screen?

- OK >> INSPECTION END
NG >> Go to [EC-213. "Diagnosis Procedure"](#).

4.PERFORM DTC CONFIRMATION PROCEDURE-II

1. After perform the following procedure, "TESTING" will be displayed on the CONSULT-III screen.
 - Increase the engine speed up to about 3,600 rpm and maintain that speed for 10 seconds.
 - Fully release accelerator pedal and then let engine idle for about 10 seconds.**If "TESTING" is not displayed after 10 seconds, go to [EC-132. "Component Function Check"](#).**
2. Wait for about 20 seconds at idle under the condition that "TESTING" is displayed on the CONSULT-III screen.
3. Make sure that "TESTING" changes to "COMPLETED".
If "TESTING" changed to "OUT OF CONDITION", go to [EC-132. "Component Function Check"](#).
4. Touch "SELF-DIAG RESULT".

Which is displayed on CONSULT-III screen?

- OK >> INSPECTION END
NG >> Go to [EC-213. "Diagnosis Procedure"](#).

5.CHECK AIR-FUEL RATIO SELF-LEARNING VALUE

With GST

1. Start engine and warm it up to normal operating temperature.
2. Select Service \$01 with GST.
3. Calculate the total value of "Short term fuel trim" and "Long term fuel trim" indications.

Is the total percentage within $\pm 15\%$?

- YES >> GO TO 7.
NO >> GO TO 6.

6.DETECT MALFUNCTIONING PART

Check the following.

- Intake air leaks
- Exhaust gas leaks
- Incorrect fuel pressure
- Lack of fuel
- Fuel injector
- Incorrect PCV hose connection
- PCV valve
- Mass air flow sensor

P0133, P0153 A/F SENSOR 1

[VQ37VHR]

< DTC/CIRCUIT DIAGNOSIS >

>> Repair or replace malfunctioning part.

7. PERFORM DTC CONFIRMATION PROCEDURE

1. Turn ignition switch OFF and wait at least 10 seconds.
2. Turn ignition switch ON.
3. Turn ignition switch OFF and wait at least 10 seconds.
4. Start engine and keep the engine speed between 3,500 and 4,000 rpm for at least 1 minute under no load.
5. Let engine idle for 1 minute.
6. Increase the engine speed up to about 3,600 rpm and keep it for 10 seconds.
7. Fully release accelerator pedal and then let engine idle for about 1 minute.
8. Check 1st trip DTC.

Is 1st trip DTC detected?

- YES >> Go to [EC-213, "Diagnosis Procedure"](#).
NO >> INSPECTION END

Diagnosis Procedure

INFOID:000000005151769

1. CHECK GROUND CONNECTION

1. Turn ignition switch OFF.
2. Check ground connection M95. Refer to Ground Inspection in [GI-39, "Circuit Inspection"](#).

Is the inspection result normal?

- YES >> GO TO 2.
NO >> Repair or replace ground connection.

2. RETIGHTEN A/F SENSOR 1

Loosen and retighten the A/F sensor 1. Refer to [EM-34, "Removal and Installation"](#).

>> GO TO 3.

3. CHECK EXHAUST GAS LEAK

1. Start engine and run it at idle.
2. Listen for an exhaust gas leak before three way catalyst 1.

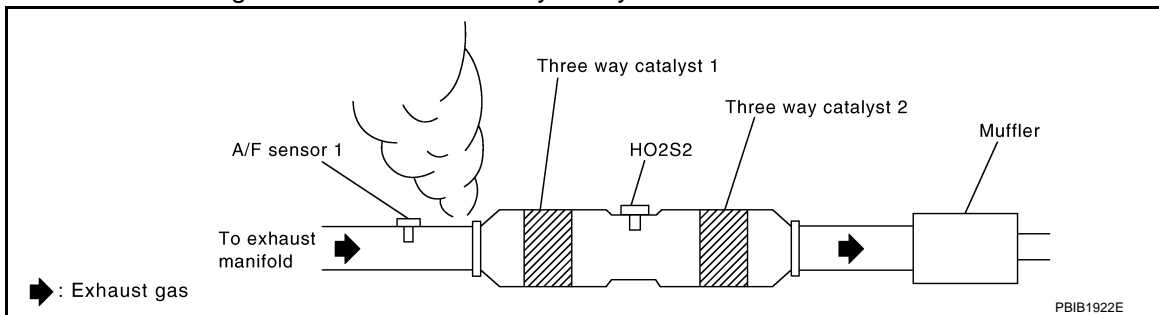

Is exhaust gas leak detected?

- YES >> Repair or replace.
NO >> GO TO 4.

4. CHECK FOR INTAKE AIR LEAK

Listen for an intake air leak after the mass air flow sensor.

Is intake air leak detected?

- YES >> Repair or replace.
NO >> GO TO 5.

5. CLEAR THE MIXTURE RATIO SELF-LEARNING VALUE

1. Clear the mixture ratio self-learning value. Refer to [EC-22, "MIXTURE RATIO SELF-LEARNING VALUE CLEAR : Special Repair Requirement"](#).
2. Run engine for at least 10 minutes at idle speed.

Is the 1st trip DTC P0171, P172, P0174 or P0175 detected? Is it difficult to start engine?

P0133, P0153 A/F SENSOR 1

[VQ37VHR]

< DTC/CIRCUIT DIAGNOSIS >

- YES >> Perform trouble diagnosis for DTC P0171, P0174 or P0172, P0175. Refer to [EC-236, "DTC Logic"](#) or [EC-240, "DTC Logic"](#).
- NO >> GO TO 6.

6. CHECK AIR FUEL RATIO (A/F) SENSOR 1 POWER SUPPLY CIRCUIT

1. Disconnect A/F sensor 1 harness connector.
2. Turn ignition switch ON.
3. Check the voltage between A/F sensor 1 harness connector and ground.

DTC	A/F sensor 1			Ground	Voltage
	Bank	Connector	Terminal		
P0133	1	F3	4	Ground	Battery voltage
P0153	2	F20	4		

Is the inspection result normal?

- YES >> GO TO 8.
NO >> GO TO 7.

7. DETECT MALFUNCTIONING PART

Check the following.

- Harness connectors E3, F1
- IPDM E/R harness connector E7
- 15 A fuse (No. 46)
- Harness for open or short between A/F sensor 1 and fuse

>> Repair or replace harness or connectors.

8. CHECK A/F SENSOR 1 INPUT SIGNAL CIRCUIT FOR OPEN AND SHORT

1. Turn ignition switch OFF.
2. Disconnect ECM harness connector.
3. Check the continuity between A/F sensor 1 harness connector and ECM harness connector.

DTC	A/F sensor 1			ECM		Continuity
	Bank	Connector	Terminal	Connector	Terminal	
P0133	1	F3	1	F102	57	Existed
			2		61	
P0153	2	F20	1		65	
			2		66	

4. Check the continuity between A/F sensor 1 harness connector and ground, or ECM harness connector and ground.

DTC	A/F sensor 1			Ground	Continuity
	Bank	Connector	Terminal		
P0133	1	F3	1	Ground	Not existed
			2		
P0153	2	F20	1		
			2		

P0133, P0153 A/F SENSOR 1

< DTC/CIRCUIT DIAGNOSIS >

[VQ37VHR]

DTC	ECM			Ground	Continuity
	Bank	Connector	Terminal		
P0133	1	F102	57	Ground	Not existed
			61		
P0153	2		65		
			66		

5. Also check harness for short to power.

Is the inspection result normal?

YES >> GO TO 9.

NO >> Repair open circuit, short to ground or short to power in harness or connectors.

9. CHECK AIR FUEL RATIO (A/F) SENSOR 1 HEATER

Refer to [EC-158. "Component Inspection"](#).

Is the inspection result normal?

YES >> GO TO 10.

NO >> GO TO 13.

10. CHECK MASS AIR FLOW SENSOR

Check both mass air flow sensor (bank 1 and bank 2).

Refer to [EC-169. "Component Inspection"](#).

Is the inspection result normal?

YES >> GO TO 11.

NO >> Replace malfunctioning mass air flow sensor.

11. CHECK PCV VALVE

Refer to [EC-514. "Component Inspection"](#).

Is the inspection result normal?

YES >> GO TO 12.

NO >> Repair or replace PCV valve.

12. CHECK INTERMITTENT INCIDENT

Perform [GI-36. "Intermittent Incident"](#).

Is the inspection result normal?

YES >> GO TO 13.

NO >> Repair or replace.

13. REPLACE AIR FUEL RATIO (A/F) SENSOR 1

Replace malfunctioning air fuel ratio (A/F) sensor 1.

CAUTION:

- Discard any A/F sensor which has been dropped from a height of more than 0.5 m (19.7 in) onto a hard surface such as a concrete floor; use a new one.
- Before installing new A/F sensor, clean exhaust system threads using Oxygen Sensor Thread Cleaner [commercial service tool (J-43897-18 or J-43897-12)] and approved Anti-seize Lubricant (commercial service tool).

>> INSPECTION END

P0137, P0157 HO2S2

Description

INFOID:000000005151770

The heated oxygen sensor 2, after three way catalyst 1, monitors the oxygen level in the exhaust gas on each bank.
 Even if switching characteristics of the air fuel ratio (A/F) sensor 1 are shifted, the air-fuel ratio is controlled to stoichiometric, by the signal from the heated oxygen sensor 2.
 This sensor is made of ceramic zirconia. The zirconia generates voltage from approximately 1 V in richer conditions to 0 V in leaner conditions.
 Under normal conditions the heated oxygen sensor 2 is not used for engine control operation.

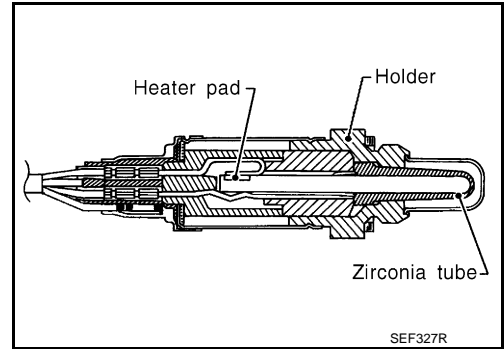

DTC Logic

INFOID:000000005151771

DTC DETECTION LOGIC

The heated oxygen sensor 2 has a much longer switching time between rich and lean than the air fuel ratio (A/F) sensor 1. The oxygen storage capacity of the three way catalyst 1 causes the longer switching time. To judge malfunctions of heated oxygen sensor 2, ECM monitors whether the maximum voltage of the sensor is sufficiently high during various driving conditions such as fuel-cut.

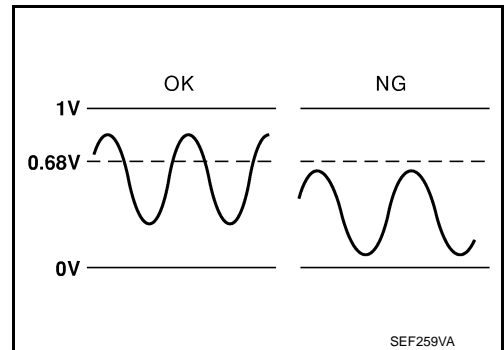

DTC No.	Trouble diagnosis name	DTC detecting condition	Possible cause
P0137	Heated oxygen sensor 2 (bank 1) circuit low voltage	The maximum voltage from the sensor does not reach the specified voltage.	<ul style="list-style-type: none"> • Harness or connectors (The sensor circuit is open or shorted) • Heated oxygen sensor 2 • Fuel pressure • Fuel injector • Intake air leaks
P0157	Heated oxygen sensor 2 (bank 2) circuit low voltage		

DTC CONFIRMATION PROCEDURE

1.INSPECTION START

Do you have CONSULT-III?

Do you have CONSULT-III?

YES >> GO TO 2.

NO >> GO TO 5.

2.PRECONDITIONING

If DTC confirmation Procedure has been previously conducted, always perform the following procedure before conducting the next test.

1. Turn ignition switch OFF and wait at least 10 seconds.
2. Turn ignition switch ON.
3. Turn ignition switch OFF and wait at least 10 seconds.

TESTING CONDITION:

For better results, perform "DTC WORK SUPPORT" at a temperature of 0 to 30°C (32 to 86°F).

>> GO TO 3.

3. PERFORM DTC CONFIRMATION PROCEDURE

With CONSULT-III

1. Turn ignition switch ON and select "DATA MONITOR" mode with CONSULT-III.
2. Start engine and warm it up to the normal operating temperature.
3. Turn ignition switch OFF and wait at least 10 seconds.
4. Turn ignition switch ON.
5. Turn ignition switch OFF and wait at least 10 seconds.
6. Start engine and keep the engine speed between 3,500 and 4,000 rpm for at least 1 minute under no load.
7. Let engine idle for 1 minute.
8. Make sure that "COOLAN TEMP/S" indicates more than 70°C (158°F).
If not, warm up engine and go to next step when "COOLAN TEMP/S" indication reaches 70°C (158°F).
9. Open engine hood.
10. Select "HO2S2 (B1) P1147" (for DTC P0137) or "HO2S2 (B2) P1167" (for DTC P0157) of "HO2S2" in "DTC WORK SUPPORT" mode with CONSULT-III.
11. Start engine and follow the instruction of CONSULT-III display.

NOTE:

It will take at most 10 minutes until "COMPLETED" is displayed.

12. Touch "SELF-DIAG RESULTS".

Which is displayed on CONSULT-III screen?

- OK >> INSPECTION END
- NG >> Go to [EC-218, "Diagnosis Procedure"](#).
- CAN NOT BE DIAGNOSED>>GO TO 4.

4. PERFORM DTC CONFIRMATION PROCEDURE AGAIN

1. Turn ignition switch OFF and leave the vehicle in a cool place (soak the vehicle).
2. Perform DTC confirmation procedure again.

>> GO TO 3.

5. PERFORM COMPONENT FUNCTION CHECK

Perform component function check. Refer to [EC-217, "Component Function Check"](#).

NOTE:

Use component function check to check the overall function of the heated oxygen sensor 2 circuit. During this check, a 1st trip DTC might not be confirmed.

Is the inspection result normal?

- YES >> INSPECTION END
- NO >> Go to [EC-218, "Diagnosis Procedure"](#).

Component Function Check

INFOID:000000005151772

1. PERFORM COMPONENT FUNCTION CHECK-I

Without CONSULT-III

1. Start engine and warm it up to the normal operating temperature.
2. Turn ignition switch OFF and wait at least 10 seconds.
3. Start engine and keep the engine speed between 3,500 and 4,000 rpm for at least 1 minute under no load.
4. Let engine idle for 1 minute.
5. Check the voltage between ECM harness connector terminals under the following condition.

DTC	ECM Connector	ECM		Condition	Voltage
		+	-		
		Terminal	Terminal		
P0137	F102	76	84	Revsing up to 4,000 rpm under no load at least 10 times	The voltage should be above 0.68 V at least once during this procedure.
P0157		80			

Is the inspection result normal?

- YES >> INSPECTION END

P0137, P0157 HO2S2

[VQ37VHR]

< DTC/CIRCUIT DIAGNOSIS >

NO >> GO TO 2.

2.PERFORM COMPONENT FUNCTION CHECK-II

Check the voltage between ECM harness connector terminals under the following condition.

DTC	ECM			Condition	Voltage
	Connector	+	-		
		Terminal	Terminal		
P0137	F102	76	84	Keeping engine at idle for 10 minutes	The voltage should be above 0.68 V at least once during this procedure.
P0157		80			

Is the inspection result normal?

YES >> INSPECTION END

NO >> GO TO 3.

3.PERFORM COMPONENT FUNCTION CHECK-III

Check the voltage between ECM harness connector terminals under the following condition.

DTC	ECM			Condition	Voltage
	Connector	+	-		
		Terminal	Terminal		
P0137	F102	76	84	Coasting from 80 km/h (50 MPH) in D position (A/T), 4th gear position (M/T)	The voltage should be above 0.68 V at least once during this procedure.
P0157		80			

Is the inspection result normal?

YES >> INSPECTION END

NO >> Go to [EC-218. "Diagnosis Procedure"](#).

Diagnosis Procedure

INFOID:000000005151773

1.CHECK GROUND CONNECTION

1. Turn ignition switch OFF.
2. Check ground connection M95. Refer to Ground Inspection in [GI-39. "Circuit Inspection"](#).

Is the inspection result normal?

YES >> GO TO 2.

NO >> Repair or replace ground connection.

2.CLEAR THE MIXTURE RATIO SELF-LEARNING VALUE

1. Clear the mixture ratio self-learning value. Refer to [EC-22. "MIXTURE RATIO SELF-LEARNING VALUE CLEAR : Special Repair Requirement"](#).
2. Run engine for at least 10 minutes at idle speed.

Is the 1st trip DTC P0171 or P0174 detected? Is it difficult to start engine?

YES >> Perform trouble diagnosis for DTC P0171 or P0174. Refer to [EC-236. "DTC Logic"](#).

NO >> GO TO 3.

3.CHECK HO2S2 GROUND CIRCUIT FOR OPEN AND SHORT

1. Turn ignition switch OFF.
2. Disconnect heated oxygen sensor 2 (HO2S2) harness connector.
3. Disconnect ECM harness connector.
4. Check the continuity between HO2S2 harness connector and ECM harness connector.

DTC	HO2S2			ECM		Continuity
	Bank	Connector	Terminal	Connector	Terminal	
P0137	1	F54	1	F102	84	Existed
P0157	2	F53	1			

< DTC/CIRCUIT DIAGNOSIS >

5. Also check harness for short to ground and short to power.

Is the inspection result normal?

YES >> GO TO 4.

NO >> Repair open circuit, short to ground or short to power in harness or connectors.

4.CHECK HO2S2 INPUT SIGNAL CIRCUIT FOR OPEN AND SHORT

1. Check the continuity between HO2S2 harness connector and ECM harness connector.

DTC	HO2S2			ECM		Continuity
	Bank	Connector	Terminal	Connector	Terminal	
P0137	1	F54	4	F102	76	Existed
P0157	2	F53	4		80	

2. Check the continuity between HO2S2 harness connector and ground, or ECM harness connector and ground.

DTC	HO2S2			Ground	Continuity
	Bank	Connector	Terminal		
P0137	1	F54	4	Ground	Not existed
P0157	2	F53	4		

DTC	ECM			Ground	Continuity
	Bank	Connector	Terminal		
P0137	1	F102	76	Ground	Not existed
P0157	2		80		

3. Also check harness for short to power.

Is the inspection result normal?

YES >> GO TO 5.

NO >> Repair open circuit, short to ground or short to power in harness or connectors.

5.CHECK HEATED OXYGEN SENSOR 2

Refer to [EC-220. "Component Inspection"](#).

Is the inspection result normal?

YES >> GO TO 7.

NO >> GO TO 6.

6.REPLACE HEATED OXYGEN SENSOR 2

Replace malfunctioning heated oxygen sensor 2.

CAUTION:

- Discard any heated oxygen sensor which has been dropped from a height of more than 0.5 m (19.7 in) onto a hard surface such as a concrete floor; use a new one.
- Before installing new heated oxygen sensor, clean exhaust system threads using Oxygen Sensor Thread Cleaner [commercial service tool (J-43897-18 or J-43897-12)] and approved Anti-seize Lubricant (commercial service tool).

>> INSPECTION END

7.CHECK INTERMITTENT INCIDENT

Refer to [GI-36. "Intermittent Incident"](#).

>> INSPECTION END

Component Inspection

INFOID:000000005151774

1.INSPECTION START

Do you have CONSULT-III?

Do you have CONSULT-III?

YES >> GO TO 2.

NO >> GO TO 3.

2.CHECK HEATED OXYGEN SENSOR 2

Ⓜ With CONSULT-III

1. Turn ignition switch ON and select "DATA MONITOR" mode with CONSULT-III.
2. Start engine and warm it up to the normal operating temperature.
3. Turn ignition switch OFF and wait at least 10 seconds.
4. Start engine and keep the engine speed between 3,500 and 4,000 rpm for at least 1 minute under no load.
5. Let engine idle for 1 minute.
6. Select "FUEL INJECTION" in "ACTIVE TEST" mode, and select "HO2S2 (B1)/(B2)" as the monitor item with CONSULT-III.
7. Check "HO2S2 (B1)/(B2)" at idle speed when adjusting "FUEL INJECTION" to $\pm 25\%$.

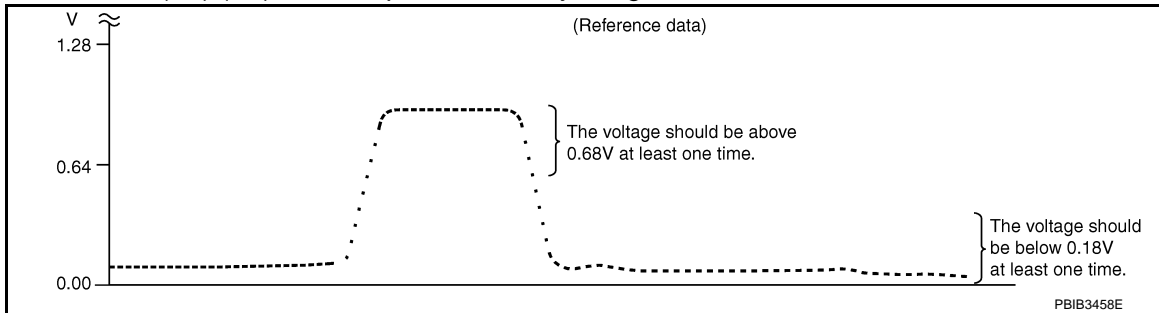

"HO2S2 (B1)/(B2)" should be above 0.68 V at least once when the "FUEL INJECTION" is +25%.

"HO2S2 (B1)/(B2)" should be below 0.18 V at least once when the "FUEL INJECTION" is -25%.

Is the inspection result normal?

YES >> INSPECTION END

NO >> GO TO 6.

3.CHECK HEATED OXYGEN SENSOR 2-I

ⓧ Without CONSULT-III

1. Start engine and warm it up to the normal operating temperature.
2. Turn ignition switch OFF and wait at least 10 seconds.
3. Start engine and keep the engine speed between 3,500 and 4,000 rpm for at least 1 minute under no load.
4. Let engine idle for 1 minute.
5. Check the voltage between ECM harness connector terminals under the following condition.

Connector	ECM		Condition	Voltage
	+	-		
	Terminal	Terminal		
F102	76 [HO2S2 (bank 1)]	84	Revving up to 4,000 rpm under no load at least 10 times	The voltage should be above 0.68 V at least once during this procedure. The voltage should be below 0.18 V at least once during this procedure.
	80 [HO2S2 (bank 2)]			

Is the inspection result normal?

YES >> INSPECTION END

NO >> GO TO 4.

4.CHECK HEATED OXYGEN SENSOR 2-II

Check the voltage between ECM harness connector terminals under the following condition.

ECM			Condition	Voltage
Connector	+	-		
	Terminal	Terminal		
F102	76 [HO2S2 (bank 1)]	84	Keeping engine at idle for 10 minutes	The voltage should be above 0.68 V at least once during this procedure. The voltage should be below 0.18 V at least once during this procedure.
	80 [HO2S2 (bank 2)]			

A

EC

C

Is the inspection result normal?

D

YES >> INSPECTION END
NO >> GO TO 5.

5.CHECK HEATED OXYGEN SENSOR 2-III

E

Check the voltage between ECM harness connector terminals under the following condition.

ECM			Condition	Voltage
Connector	+	-		
	Terminal	Terminal		
F102	76 [HO2S2 (bank 1)]	84	Coasting from 80 km/h (50 MPH) in D position (A/T), 4th gear position (M/T)	The voltage should be above 0.68 V at least once during this procedure. The voltage should be below 0.18 V at least once during this procedure.
	80 [HO2S2 (bank 2)]			

F

G

H

I

Is the inspection result normal?

YES >> INSPECTION END
NO >> GO TO 6.

J

6.REPLACE HEATED OXYGEN SENSOR 2

Replace malfunctioning heated oxygen sensor 2.

K

CAUTION:

- Discard any heated oxygen sensor which has been dropped from a height of more than 0.5 m (19.7 in) onto a hard surface such as a concrete floor; use a new one.
- Before installing new heated oxygen sensor, clean exhaust system threads using Oxygen Sensor Thread Cleaner [commercial service tool (J-43897-18 or J-43897-12)] and approved Anti-seize Lubricant (commercial service tool).

L

M

>> INSPECTION END

N

O

P

P0138, P0158 HO2S2

Description

INFOID:000000005151775

The heated oxygen sensor 2, after three way catalyst 1, monitors the oxygen level in the exhaust gas on each bank. Even if switching characteristics of the air fuel ratio (A/F) sensor 1 are shifted, the air-fuel ratio is controlled to stoichiometric, by the signal from the heated oxygen sensor 2. This sensor is made of ceramic zirconia. The zirconia generates voltage from approximately 1 V in richer conditions to 0 V in leaner conditions. Under normal conditions the heated oxygen sensor 2 is not used for engine control operation.

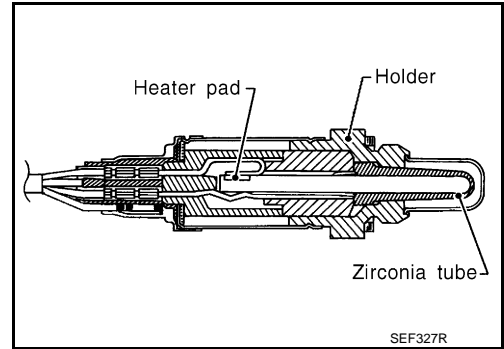

DTC Logic

INFOID:000000005151776

DTC DETECTION LOGIC

The heated oxygen sensor 2 has a much longer switching time between rich and lean than the air fuel ratio (A/F) sensor 1. The oxygen storage capacity of the three way catalyst 1 causes the longer switching time.

MALFUNCTION A

To judge malfunctions of heated oxygen sensor 2, ECM monitors whether the voltage is unusually high during various driving conditions such as fuel cut.

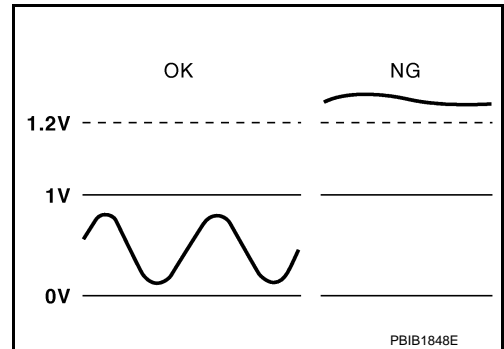

MALFUNCTION B

To judge malfunctions of heated oxygen sensor 2, ECM monitors whether the minimum voltage of sensor is sufficiently low during various driving conditions such as fuel cut.

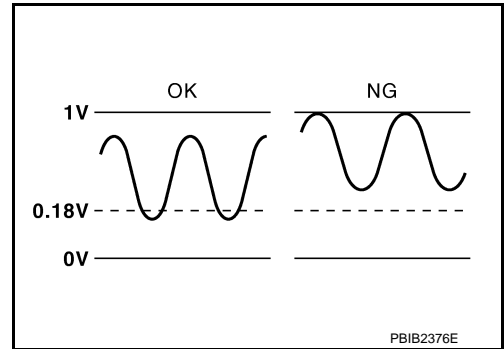

DTC No.	Trouble diagnosis name	DTC detecting condition		Possible cause
P0138	Heated oxygen sensor 2 (bank 1) circuit high voltage	A)	An excessively high voltage from the sensor is sent to ECM.	<ul style="list-style-type: none"> • Harness or connectors (The sensor circuit is open or shorted) • Heated oxygen sensor 2
		B)	The minimum voltage from the sensor is not reached to the specified voltage.	<ul style="list-style-type: none"> • Harness or connectors (The sensor circuit is open or shorted) • Heated oxygen sensor 2 • Fuel pressure • Fuel injector

P0138, P0158 HO2S2

[VQ37VHR]

< DTC/CIRCUIT DIAGNOSIS >

DTC No.	Trouble diagnosis name	DTC detecting condition		Possible cause
P0158	Heated oxygen sensor 2 (bank 2) circuit high voltage	A)	An excessively high voltage from the sensor is sent to ECM.	<ul style="list-style-type: none"> • Harness or connectors (The sensor circuit is open or shorted) • Heated oxygen sensor 2
		B)	The minimum voltage from the sensor is not reached to the specified voltage.	<ul style="list-style-type: none"> • Harness or connectors (The sensor circuit is open or shorted) • Heated oxygen sensor 2 • Fuel pressure • Fuel injector

DTC CONFIRMATION PROCEDURE

1. PRECONDITIONING

If DTC Confirmation Procedure has been previously conducted, always perform the following procedure before conducting the next test.

1. Turn ignition switch OFF and wait at least 10 seconds.
2. Turn ignition switch ON.
3. Turn ignition switch OFF and wait at least 10 seconds.

>> GO TO 2.

2. PERFORM DTC CONFIRMATION PROCEDURE FOR MALFUNCTION A

1. Start engine and warm it up to the normal operating temperature.
2. Turn ignition switch OFF and wait at least 10 seconds.
3. Turn ignition switch ON.
4. Turn ignition switch OFF and wait at least 10 seconds.
5. Start engine and keep the engine speed between 3,500 and 4,000 rpm for at least 1 minute under no load.
6. Let engine idle for 2 minutes.
7. Check 1st trip DTC.

Is 1st trip DTC detected?

YES >> Go to [EC-225, "Diagnosis Procedure"](#).

NO-1 >> With CONSULT-III: GO TO 3.

NO-2 >> Without CONSULT-III: GO TO 5.

3. PERFORM DTC CONFIRMATION PROCEDURE FOR MALFUNCTION B

NOTE:

For better results, perform "DTC WORK SUPPORT" at a temperature of 0 to 30 °C (32 to 86 °F).

1. Select "DATA MONITOR" mode with CONSULT-III.
2. Start engine and warm it up to the normal operating temperature.
3. Turn ignition switch OFF and wait at least 10 seconds.
4. Turn ignition switch ON.
5. Turn ignition switch OFF and wait at least 10 seconds.
6. Start engine and keep the engine speed between 3,500 and 4,000 rpm for at least 1 minute under no load.
7. Let engine idle for 1 minute.
8. Make sure that "COOLAN TEMP/S" indicates more than 70°C (158°F).
If not, warm up engine and go to next step when "COOLAN TEMP/S" indication reaches 70°C (158°F).
9. Open engine hood.
10. Select "HO2S2 (B1) P1146" (for DTC P0138) or "HO2S2 (B2) P1166" (for DTC P0158) of "HO2S2" in "DTC WORK SUPPORT" mode with CONSULT-III.
11. Start engine and follow the instruction of CONSULT-III display.

NOTE:

It will take at most 10 minutes until "COMPLETED" is displayed.

12. Touch "SELF-DIAG RESULTS".

Which is displayed on CONSULT-III screen?

OK >> INSPECTION END

NG >> Go to [EC-225, "Diagnosis Procedure"](#).

CON NOT BE DIAGNOSED>>GO TO 4.

4. PERFORM DTC CONFIRMATION PROCEDURE FOR MALFUNCTION B AGAIN

1. Turn ignition switch OFF and leave the vehicle in a cool place (soak the vehicle).

< DTC/CIRCUIT DIAGNOSIS >

2. Perform DTC confirmation procedure again.

>> GO TO 3.

5. PERFORM COMPONENT FUNCTION CHECK FOR MALFUNCTION B

Perform component function check. Refer to [EC-224, "Component Function Check"](#).

NOTE:

Use component function check to check the overall function of the heated oxygen sensor 2 circuit. During this check, a 1st trip DTC might not be confirmed.

Is the inspection result normal?

YES >> INSPECTION END

NO >> Go to [EC-225, "Diagnosis Procedure"](#).

Component Function Check

INFOID:000000005151777

1. PERFORM COMPONENT FUNCTION CHECK-I

⊗ Without CONSULT-III

1. Start engine and warm it up to the normal operating temperature.
2. Turn ignition switch OFF and wait at least 10 seconds.
3. Start engine and keep the engine speed between 3,500 and 4,000 rpm for at least 1 minute under no load.
4. Let engine idle for 1 minute.
5. Check the voltage between ECM harness connector terminals under the following condition.

DTC	ECM		Condition	Voltage	
	Connector	+			-
		Terminal			Terminal
P0138 P0158	F102	76 80	84	Reving up to 4,000 rpm under no load at least 10 times The voltage should be below 0.18 V at least once during this procedure.	

Is the inspection result normal?

YES >> INSPECTION END

NO >> GO TO 2.

2. PERFORM COMPONENT FUNCTION CHECK-II

Check the voltage between ECM harness connector terminals under the following condition.

DTC	ECM		Condition	Voltage	
	Connector	+			-
		Terminal			Terminal
P0138 P0158	F102	76 80	84	Keeping engine at idle for 10 minutes The voltage should be below 0.18 V at least once during this procedure.	

Is the inspection result normal?

YES >> INSPECTION END

NO >> GO TO 3.

3. PERFORM COMPONENT FUNCTION CHECK-III

Check the voltage between ECM harness connector terminals under the following condition.

DTC	ECM		Condition	Voltage	
	Connector	+			-
		Terminal			Terminal
P0138 P0158	F102	76 80	84	Coasting from 80 km/h (50 MPH) in D position (A/T), 4th gear position (M/T) The voltage should be below 0.18 V at least once during this procedure.	

< DTC/CIRCUIT DIAGNOSIS >

Is the inspection result normal?

- YES >> INSPECTION END
- NO >> Go to [EC-225, "Diagnosis Procedure"](#).

Diagnosis Procedure

INFOID:000000005151778

1.INSPECTION START

Confirm the detected malfunction (A or B). Refer to [EC-222, "DTC Logic"](#).

Which malfunction is detected?

- A >> GO TO 2
- B >> GO TO 9.

2.CHECK GROUND CONNECTION

1. Turn ignition switch OFF.
2. Check ground connection M95. Refer to Ground Inspection in [GI-39, "Circuit Inspection"](#).

Is the inspection result normal?

- YES >> GO TO 3.
- NO >> Repair or replace ground connection.

3.CHECK HO2S2 GROUND CIRCUIT FOR OPEN AND SHORT

1. Disconnect heated oxygen sensor 2 (HO2S2) harness connector.
2. Disconnect ECM harness connector.
3. Check the continuity between HO2S2 harness connector and ECM harness connector.

DTC	HO2S2			ECM		Continuity
	Bank	Connector	Terminal	Connector	Terminal	
P0138	1	F54	1	F102	84	Existed
P0158	2	F53	1			

4. Also check harness for short to ground and short to power.

Is the inspection result normal?

- YES >> GO TO 4.
- NO >> Repair open circuit, short to ground or short to power in harness or connectors.

4.CHECK HO2S2 INPUT SIGNAL CIRCUIT FOR OPEN AND SHORT

1. Check the continuity between HO2S2 harness connector and ECM harness connector.

DTC	HO2S2			ECM		Continuity
	Bank	Connector	Terminal	Connector	Terminal	
P0138	1	F54	4	F102	76	Existed
P0158	2	F53	4		80	

2. Check the continuity between HO2S2 harness connector and ground, or ECM harness connector and ground.

DTC	HO2S2			Ground	Continuity
	Bank	Connector	Terminal		
P0138	1	F54	4	Ground	Not existed
P0158	2	F53	4		

DTC	ECM			Ground	Continuity
	Bank	Connector	Terminal		
P0138	1	F102	76	Ground	Not existed
P0158	2		80		

< DTC/CIRCUIT DIAGNOSIS >

3. Also check harness for short to power.

Is the inspection result normal?

YES >> GO TO 5.

NO >> Repair open circuit, short to ground or short to power in harness or connectors.

5.CHECK HO2S2 CONNECTOR FOR WATER

Check connectors for water.

Water should not exist.

Is the inspection result normal?

YES >> GO TO 6.

NO >> Repair or replace harness or connectors.

6.CHECK HEATED OXYGEN SENSOR 2

Refer to [EC-227, "Component Inspection"](#).

Is the inspection result normal?

YES >> GO TO 8.

NO >> GO TO 7.

7.REPLACE HEATED OXYGEN SENSOR 2

Replace malfunctioning heated oxygen sensor 2.

CAUTION:

- Discard any heated oxygen sensor which has been dropped from a height of more than 0.5 m (19.7 in) onto a hard surface such as a concrete floor; use a new one.
- Before installing new heated oxygen sensor, clean exhaust system threads using Oxygen Sensor Thread Cleaner [commercial service tool (J-43897-18 or J-43897-12)] and approved Anti-seize Lubricant (commercial service tool).

>> INSPECTION END

8.CHECK INTERMITTENT INCIDENT

Refer to [GI-36, "Intermittent Incident"](#).

>> INSPECTION END

9.CHECK GROUND CONNECTION

1. Turn ignition switch OFF.

2. Check ground connection M95. Refer to Ground Inspection in [GI-39, "Circuit Inspection"](#).

Is the inspection result normal?

YES >> GO TO 10.

NO >> Repair or replace ground connection.

10.CLEAR THE MIXTURE RATIO SELF-LEARNING VALUE

1. Clear the mixture ratio self-learning value. Refer to [EC-22, "MIXTURE RATIO SELF-LEARNING VALUE CLEAR : Special Repair Requirement"](#).

2. Run engine for at least 10 minutes at idle speed.

Is the 1st trip DTC P0172 or P0175 detected? Is it difficult to start engine?

YES >> Perform trouble diagnosis for DTC P0172, P0175. Refer to [EC-240, "DTC Logic"](#).

NO >> GO TO 11.

11.CHECK HO2S2 GROUND CIRCUIT FOR OPEN AND SHORT

1. Turn ignition switch OFF.

2. Disconnect heated oxygen sensor 2 harness connector.

3. Disconnect ECM harness connector.

4. Check the continuity between HO2S2 harness connector and ECM harness connector.

DTC	HO2S2			ECM		Continuity
	Bank	Connector	Terminal	Connector	Terminal	
P0138	1	F54	1	F102	84	Existed
P0158	2	F53	1			

5. Also check harness for short to ground and short to power.

Is the inspection result normal?

YES >> GO TO 12.

NO >> Repair open circuit, short to ground or short to power in harness or connectors.

12.CHECK HO2S2 INPUT SIGNAL CIRCUIT FOR OPEN AND SHORT

1. Check the continuity between HO2S2 harness connector and ECM harness connector.

DTC	HO2S2			ECM		Continuity
	Bank	Connector	Terminal	Connector	Terminal	
P0138	1	F54	4	F102	76	Existed
P0158	2	F53	4		80	

2. Check the continuity between HO2S2 harness connector or ECM harness connector and ground.

DTC	HO2S2			ECM		Ground	Continuity
	Bank	Connector	Terminal	Connector	Terminal		
P0138	1	F54	4	F102	76	Ground	Not existed
P0158	2	F53	4		80		

3. Also check harness for short to power.

Is the inspection result normal?

YES >> GO TO 13.

NO >> Repair open circuit, short to ground or short to power in harness or connectors.

13.CHECK HEATED OXYGEN SENSOR 2

Refer to [EC-224, "Component Function Check"](#).

Is the inspection result normal?

YES >> GO TO 15.

NO >> GO TO 14.

14.REPLACE HEATED OXYGEN SENSOR 2

Replace malfunctioning heated oxygen sensor 2.

CAUTION:

- Discard any heated oxygen sensor which has been dropped from a height of more than 0.5 m (19.7 in) onto a hard surface such as a concrete floor; use a new one.
- Before installing new heated oxygen sensor, clean exhaust system threads using Oxygen Sensor Thread Cleaner [commercial service tool (J-43897-18 or J-43897-12)] and approved Anti-seize Lubricant (commercial service tool).

>> INSPECTION END

15.CHECK INTERMITTENT INCIDENT

Refer to [GI-36, "Intermittent Incident"](#).

>> INSPECTION END

Component Inspection

1.INSPECTION START

< DTC/CIRCUIT DIAGNOSIS >

Do you have CONSULT-III?

Do you have CONSULT-III?

- YES >> GO TO 2.
- NO >> GO TO 3.

2.CHECK HEATED OXYGEN SENSOR 2

④ With CONSULT-III

1. Turn ignition switch ON and select "DATA MONITOR" mode with CONSULT-III.
2. Start engine and warm it up to the normal operating temperature.
3. Turn ignition switch OFF and wait at least 10 seconds.
4. Start engine and keep the engine speed between 3,500 and 4,000 rpm for at least 1 minute under no load.
5. Let engine idle for 1 minute.
6. Select "FUEL INJECTION" in "ACTIVE TEST" mode, and select "HO2S2 (B1)/(B2)" as the monitor item with CONSULT-III.
7. Check "HO2S2 (B1)/(B2)" at idle speed when adjusting "FUEL INJECTION" to $\pm 25\%$.

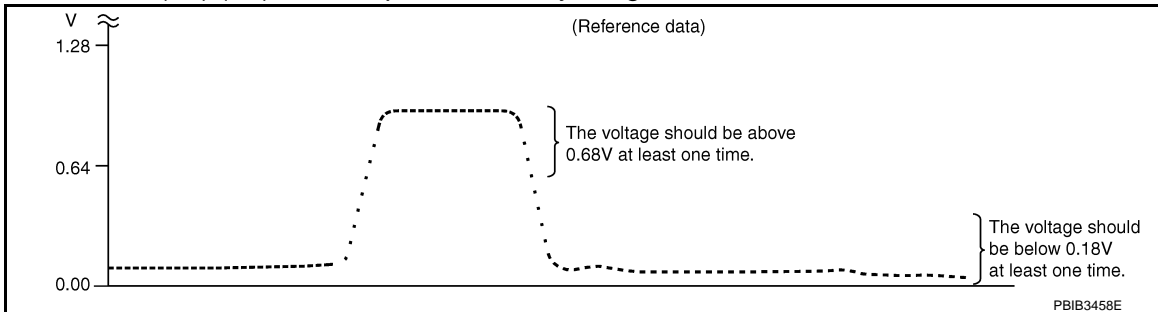

"HO2S2 (B1)/(B2)" should be above 0.68 V at least once when the "FUEL INJECTION" is +25%.
"HO2S2 (B1)/(B2)" should be below 0.18 V at least once when the "FUEL INJECTION" is -25%.

Is the inspection result normal?

- YES >> INSPECTION END
- NO >> GO TO 6.

3.CHECK HEATED OXYGEN SENSOR 2-I

⊗ Without CONSULT-III

1. Start engine and warm it up to the normal operating temperature.
2. Turn ignition switch OFF and wait at least 10 seconds.
3. Start engine and keep the engine speed between 3,500 and 4,000 rpm for at least 1 minute under no load.
4. Let engine idle for 1 minute.
5. Check the voltage between ECM harness connector terminals under the following condition.

ECM		Condition	Voltage
Connector	+ Terminal		
F102	76 [HO2S2 (bank 1)]	Revving up to 4,000 rpm under no load at least 10 times	The voltage should be above 0.68 V at least once during this procedure. The voltage should be below 0.18 V at least once during this procedure.
	80 [HO2S2 (bank 2)]		

Is the inspection result normal?

- YES >> INSPECTION END
- NO >> GO TO 4.

4.CHECK HEATED OXYGEN SENSOR 2-II

Check the voltage between ECM harness connector terminals under the following condition.

ECM			Condition	Voltage
Connector	+	-		
	Terminal	Terminal		
F102	76 [HO2S2 (bank 1)]	84	Keeping engine at idle for 10 minutes	The voltage should be above 0.68 V at least once during this procedure. The voltage should be below 0.18 V at least once during this procedure.
	80 [HO2S2 (bank 2)]			

A

EC

C

Is the inspection result normal?

D

YES >> INSPECTION END
NO >> GO TO 5.

5. CHECK HEATED OXYGEN SENSOR 2-III

E

Check the voltage between ECM harness connector terminals under the following condition.

ECM			Condition	Voltage
Connector	+	-		
	Terminal	Terminal		
F102	76 [HO2S2 (bank 1)]	84	Coasting from 80 km/h (50 MPH) in D position (A/T), 4th gear position (M/T)	The voltage should be above 0.68 V at least once during this procedure. The voltage should be below 0.18 V at least once during this procedure.
	80 [HO2S2 (bank 2)]			

F

G

H

I

Is the inspection result normal?

J

YES >> INSPECTION END
NO >> GO TO 6.

6. REPLACE HEATED OXYGEN SENSOR 2

Replace malfunctioning heated oxygen sensor 2.

K

CAUTION:

- Discard any heated oxygen sensor which has been dropped from a height of more than 0.5 m (19.7 in) onto a hard surface such as a concrete floor; use a new one.
- Before installing new heated oxygen sensor, clean exhaust system threads using Oxygen Sensor Thread Cleaner [commercial service tool (J-43897-18 or J-43897-12)] and approved Anti-seize Lubricant (commercial service tool).

L

M

>> INSPECTION END

N

O

P

P0139, P0159 HO2S2

Description

INFOID:000000005151780

The heated oxygen sensor 2, after three way catalyst 1, monitors the oxygen level in the exhaust gas on each bank.
 Even if switching characteristics of the air fuel ratio (A/F) sensor 1 are shifted, the air-fuel ratio is controlled to stoichiometric, by the signal from the heated oxygen sensor 2.
 This sensor is made of ceramic zirconia. The zirconia generates voltage from approximately 1 V in richer conditions to 0V in leaner conditions.
 Under normal conditions the heated oxygen sensor 2 is not used for engine control operation.

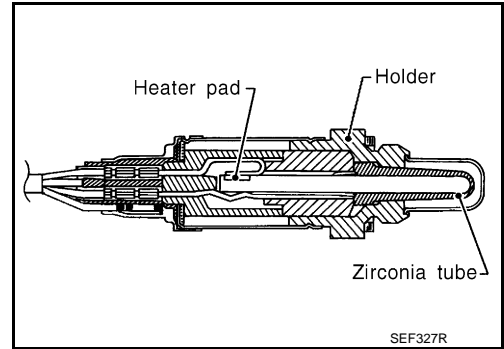

DTC Logic

INFOID:000000005151781

DTC DETECTION LOGIC

The heated oxygen sensor 2 has a much longer switching time between rich and lean than the air fuel ratio (A/F) sensor 1. The oxygen storage capacity of the three way catalyst 1 causes the longer switching time. To judge the malfunctions of heated oxygen sensor 2, ECM monitors whether the switching response of the sensor's voltage is faster than specified during various driving conditions such as fuel cut.

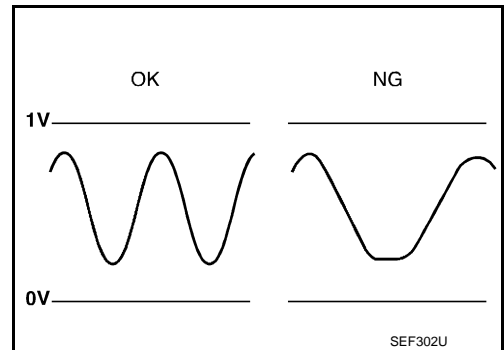

DTC No.	Trouble diagnosis name	DTC detecting condition	Possible cause
P0139	Heated oxygen sensor 2 (bank 1) circuit slow response	It takes more time for the sensor to respond between rich and lean than the specified time.	<ul style="list-style-type: none"> • Harness or connectors (The sensor circuit is open or shorted) • Heated oxygen sensor 2 • Fuel pressure • Fuel injector • Intake air leaks
P0159	Heated oxygen sensor 2 (bank 2) circuit slow response		

DTC CONFIRMATION PROCEDURE

1.INSPECTION START

Do you have CONSULT-III?

Do you have CONSULT-III?

YES >> GO TO 2.

NO >> GO TO 5.

2.PRECONDITIONING

If DTC Confirmation Procedure has been previously conducted, always perform the following procedure before conducting the next test.

1. Turn ignition switch OFF and wait at least 10 seconds.
2. Turn ignition switch ON.
3. Turn ignition switch OFF and wait at least 10 seconds.

TESTING CONDITION:

For better results, perform "DTC WORK SUPPORT" at a temperature of 0 to 30°C (32 to 86°F).

>> GO TO 3.

3. PERFORM DTC CONFIRMATION PROCEDURE

With CONSULT-III

1. Turn ignition switch ON and select "DATA MONITOR" mode with CONSULT-III.
 2. Start engine and warm it up to the normal operating temperature.
 3. Turn ignition switch OFF and wait at least 10 seconds.
 4. Turn ignition switch ON.
 5. Turn ignition switch OFF and wait at least 10 seconds.
 6. Start engine and keep the engine speed between 3,500 and 4,000 rpm for at least 1 minute under no load.
 7. Let engine idle for 1 minute.
 8. Make sure that "COOLAN TEMP/S" indicates more than 70°C (158°F).
If not, warm up engine and go to next step when "COOLAN TEMP/S" indication reaches to 70°C (158°F).
 9. Open engine hood.
 10. Select "HO2S2 (B1) P0139" or "HO2S2 (B2) P0159" of "HO2S2" in "DTC WORK SUPPORT" mode with CONSULT-III.
 11. Start engine and follow the instruction of CONSULT-III display.
- NOTE:**
It will take at most 10 minutes until "COMPLETED" is displayed.
12. Touch "SELF-DIAG RESULTS".

Which is displayed on CONSULT-III screen?

- OK >> INSPECTION END
- NG >> Go to [EC-232, "Diagnosis Procedure"](#).
- CAN NOT BE DIAGNOSED>>GO TO 4.

4. PERFORM DTC CONFIRMATION PROCEDURE AGAIN

1. Turn ignition switch OFF and leave the vehicle in a cool place (soak the vehicle).
2. Perform DTC confirmation procedure again.

>> GO TO 3.

5. PERFORM COMPONENT FUNCTION CHECK

Perform component function check. Refer to [EC-231, "Component Function Check"](#).

NOTE:

Use component function check to check the overall function of the heated oxygen sensor 2 circuit. During this check, a 1st trip DTC might not be confirmed.

Is the inspection result normal?

- YES >> INSPECTION END
- NO >> Go to [EC-232, "Diagnosis Procedure"](#).

Component Function Check

INFOID:000000005151782

1. PERFORM COMPONENT FUNCTION CHECK-I

Without CONSULT-III

1. Start engine and warm it up to the normal operating temperature.
2. Turn ignition switch OFF and wait at least 10 seconds.
3. Start engine and keep the engine speed between 3,500 and 4,000 rpm for at least 1 minute under no load.
4. Let engine idle for 1 minute.
5. Check the voltage between ECM harness connector terminals under the following condition.

DTC	Connector	ECM		Condition	Voltage
		+	-		
		Terminal	Terminal		
P0139	F102	76	84	Revving up to 4,000 rpm under no load at least 10 times	A change of voltage should be more than 0.24 V for 1 second during this procedure.
P0159		80			

Is the inspection result normal?

- YES >> INSPECTION END

< DTC/CIRCUIT DIAGNOSIS >

NO >> GO TO 2.

2.PERFORM COMPONENT FUNCTION CHECK-II

Check the voltage between ECM harness connector terminals under the following condition.

DTC	ECM			Condition	Voltage
	Connector	+	-		
		Terminal	Terminal		
P0139	F102	76	84	Keeping engine at idle for 10 minutes	A change of voltage should be more than 0.24 V for 1 second during this procedure.
P0159		80			

Is the inspection result normal?

YES >> INSPECTION END

NO >> GO TO 3.

3.PERFORM COMPONENT FUNCTION CHECK-III

Check the voltage between ECM harness connector terminals under the following condition.

DTC	ECM			Condition	Voltage
	Connector	+	-		
		Terminal	Terminal		
P0139	F102	76	84	Coasting from 80 km/h (50 MPH) in D position (A/T), 4th gear position (M/T)	A change of voltage should be more than 0.24 V for 1 second during this procedure.
P0159		80			

Is the inspection result normal?

YES >> INSPECTION END

NO >> Go to [EC-232, "Diagnosis Procedure"](#).

Diagnosis Procedure

INFOID:000000005151783

1.CHECK GROUND CONNECTION

1. Turn ignition switch OFF.
2. Check ground connection M95. Refer to Ground Inspection in [GI-39, "Circuit Inspection"](#).

Is the inspection result normal?

YES >> GO TO 2.

NO >> Repair or replace ground connection.

2.CLEAR THE MIXTURE RATIO SELF-LEARNING VALUE

1. Clear the mixture ratio self-learning value. Refer to [EC-22, "MIXTURE RATIO SELF-LEARNING VALUE CLEAR : Special Repair Requirement"](#).
2. Run engine for at least 10 minutes at idle speed.

Is the 1st trip DTC P0171, P0172, P0174 or P0175 detected? Is it difficult to start engine?

YES >> Perform trouble diagnosis for DTC P0171, P0174 or P0172, P0175. Refer to [EC-236, "DTC Logic"](#) or [EC-240, "DTC Logic"](#).

NO >> GO TO 3.

3.CHECK HO2S2 GROUND CIRCUIT FOR OPEN AND SHORT

1. Turn ignition switch OFF.
2. Disconnect heated oxygen sensor 2 (HO2S2) harness connector.
3. Disconnect ECM harness connector.
4. Check the continuity between HO2S2 harness connector and ECM harness connector.

< DTC/CIRCUIT DIAGNOSIS >

DTC	HO2S2			ECM		Continuity
	Bank	Connector	Terminal	Connector	Terminal	
P0139	1	F54	1	F102	84	Existed
P0159	2	F53	1			

5. Also check harness for short to ground and short to power.

Is the inspection result normal?

YES >> GO TO 4.

NO >> Repair open circuit, short to ground or short to power in harness or connectors.

4.CHECK HO2S2 INPUT SIGNAL CIRCUIT FOR OPEN AND SHORT

1. Check the continuity between HO2S2 harness connector and ECM harness connector.

DTC	HO2S2			ECM		Continuity
	Bank	Connector	Terminal	Connector	Terminal	
P0139	1	F54	4	F102	76	Existed
P0159	2	F53	4		80	

2. Check the continuity between HO2S2 harness connector and ground, or ECM harness connector and ground.

DTC	HO2S2			Ground	Continuity
	Bank	Connector	Terminal		
P0139	1	F54	4	Ground	Not existed
P0159	2	F53	4		

DTC	ECM			Ground	Continuity
	Bank	Connector	Terminal		
P0139	1	F102	76	Ground	Not existed
P0159	2		80		

3. Also check harness for short to power.

Is the inspection result normal?

YES >> GO TO 5.

NO >> Repair open circuit, short to ground or short to power in harness or connectors.

5.CHECK HEATED OXYGEN SENSOR 2

Refer to [EC-234. "Component Inspection"](#).

Is the inspection result normal?

YES >> GO TO 7.

NO >> GO TO 6.

6.REPLACE HEATED OXYGEN SENSOR 2

Replace malfunctioning heated oxygen sensor 2.

CAUTION:

- Discard any heated oxygen sensor which has been dropped from a height of more than 0.5 m (19.7 in) onto a hard surface such as a concrete floor; use a new one.
- Before installing new heated oxygen sensor, clean exhaust system threads using Oxygen Sensor Thread Cleaner [commercial service tool (J-43897-18 or J-43897-12)] and approved Anti-seize Lubricant (commercial service tool).

>> INSPECTION END

7.CHECK INTERMITTENT INCIDENT

A
EC

C

D

E

F

G

H

I

J

K

L

M

N

O

P

< DTC/CIRCUIT DIAGNOSIS >

Refer to [GI-36, "Intermittent Incident"](#).

>> INSPECTION END

Component Inspection

INFOID:000000005151784

1.INSPECTION START

Do you have CONSULT-III?

Do you have CONSULT-III?

YES >> GO TO 2.

NO >> GO TO 3.

2.CHECK HEATED OXYGEN SENSOR 2

 With CONSULT-III

1. Turn ignition switch ON and select "DATA MONITOR" mode with CONSULT-III.
2. Start engine and warm it up to the normal operating temperature.
3. Turn ignition switch OFF and wait at least 10 seconds.
4. Start engine and keep the engine speed between 3,500 and 4,000 rpm for at least 1 minute under no load.
5. Let engine idle for 1 minute.
6. Select "FUEL INJECTION" in "ACTIVE TEST" mode, and select "HO2S2 (B1)/(B2)" as the monitor item with CONSULT-III.
7. Check "HO2S2 (B1)/(B2)" at idle speed when adjusting "FUEL INJECTION" to $\pm 25\%$.

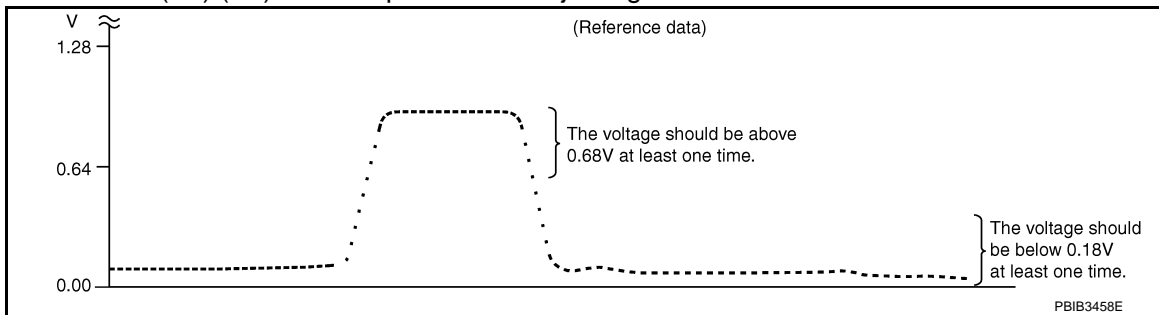

"HO2S2 (B1)/(B2)" should be above 0.68 V at least once when the "FUEL INJECTION" is +25%.

"HO2S2 (B1)/(B2)" should be below 0.18 V at least once when the "FUEL INJECTION" is -25%.

Is the inspection result normal?

YES >> INSPECTION END

NO >> GO TO 6.

3.CHECK HEATED OXYGEN SENSOR 2-I

 Without CONSULT-III

1. Start engine and warm it up to the normal operating temperature.
2. Turn ignition switch OFF and wait at least 10 seconds.
3. Start engine and keep the engine speed between 3,500 and 4,000 rpm for at least 1 minute under no load.
4. Let engine idle for 1 minute.
5. Check the voltage between ECM harness connector terminals under the following condition.

Connector	ECM		Condition	Voltage
	+	-		
	Terminal	Terminal		
F102	76 [HO2S2 (bank 1)]	84	Revving up to 4,000 rpm under no load at least 10 times	The voltage should be above 0.68 V at least once during this procedure. The voltage should be below 0.18 V at least once during this procedure.
	80 [HO2S2 (bank 2)]			

Is the inspection result normal?

YES >> INSPECTION END

< DTC/CIRCUIT DIAGNOSIS >

NO >> GO TO 4.

4.CHECK HEATED OXYGEN SENSOR 2-II

Check the voltage between ECM harness connector terminals under the following condition.

ECM			Condition	Voltage
Connector	+	-		
	Terminal	Terminal		
F102	76 [HO2S2 (bank 1)]	84	Keeping engine at idle for 10 minutes	The voltage should be above 0.68 V at least once during this procedure. The voltage should be below 0.18 V at least once during this procedure.
	80 [HO2S2 (bank 2)]			

Is the inspection result normal?

YES >> INSPECTION END

NO >> GO TO 5.

5.CHECK HEATED OXYGEN SENSOR 2-III

Check the voltage between ECM harness connector terminals under the following condition.

ECM			Condition	Voltage
Connector	+	-		
	Terminal	Terminal		
F102	76 [HO2S2 (bank 1)]	84	Coasting from 80 km/h (50 MPH) in D position (A/T), 4th gear position (M/T)	The voltage should be above 0.68 V at least once during this procedure. The voltage should be below 0.18 V at least once during this procedure.
	80 [HO2S2 (bank 2)]			

Is the inspection result normal?

YES >> INSPECTION END

NO >> GO TO 6.

6.REPLACE HEATED OXYGEN SENSOR 2

Replace malfunctioning heated oxygen sensor 2.

CAUTION:

- Discard any heated oxygen sensor which has been dropped from a height of more than 0.5 m (19.7 in) onto a hard surface such as a concrete floor; use a new one.
- Before installing new heated oxygen sensor, clean exhaust system threads using Oxygen Sensor Thread Cleaner [commercial service tool (J-43897-18 or J-43897-12)] and approved Anti-seize Lubricant (commercial service tool).

>> INSPECTION END

P0171, P0174 FUEL INJECTION SYSTEM FUNCTION

[VQ37VHR]

< DTC/CIRCUIT DIAGNOSIS >

P0171, P0174 FUEL INJECTION SYSTEM FUNCTION

DTC Logic

INFOID:000000005151785

DTC DETECTION LOGIC

With the Air/Fuel Mixture Ratio Self-Learning Control, the actual mixture ratio can be brought closely to the theoretical mixture ratio based on the mixture ratio feedback signal from A/F sensor 1. The ECM calculates the necessary compensation to correct the offset between the actual and the theoretical ratios.

In case the amount of the compensation value is extremely large (the actual mixture ratio is too lean), the ECM judges the condition as the fuel injection system malfunction and illuminates the MIL (2 trip detection logic).

Sensor	Input signal to ECM	ECM function	Actuator
A/F sensor 1	Density of oxygen in exhaust gas (Mixture ratio feedback signal)	Fuel injection control	Fuel injector

DTC No.	Trouble diagnosis name	DTC detecting condition	Possible cause
P0171	Fuel injection system too lean (bank 1)	• Fuel injection system does not operate properly. • The amount of mixture ratio compensation is too large. (The mixture ratio is too lean.)	• Intake air leaks • A/F sensor 1 • Fuel injector • Exhaust gas leaks • Incorrect fuel pressure • Lack of fuel • Mass air flow sensor • Incorrect PCV hose connection
P0174	Fuel injection system too lean (bank 2)		

DTC CONFIRMATION PROCEDURE

1. PRECONDITIONING

If DTC Confirmation Procedure has been previously conducted, always perform the following procedure before conducting the next test.

1. Turn ignition switch OFF and wait at least 10 seconds.
2. Turn ignition switch ON.
3. Turn ignition switch OFF and wait at least 10 seconds.

>> GO TO 2.

2. PERFORM DTC CONFIRMATION PROCEDURE-I

1. Clear the mixture ratio self-learning value. Refer to [EC-22. "MIXTURE RATIO SELF-LEARNING VALUE CLEAR : Special Repair Requirement"](#).
2. Start engine.

Is it difficult to start engine?

YES >> GO TO 3.

NO >> GO TO 4.

3. RESTART ENGINE

If it is difficult to start engine, the fuel injection system has a malfunction, too.

Crank engine while depressing accelerator pedal.

NOTE:

When depressing accelerator pedal three fourths (3/4) or more, the control system does not start the engine. Do not depress accelerator pedal too much.

Does engine start?

YES >> Go to [EC-237. "Diagnosis Procedure"](#).

NO >> Check exhaust and intake air leak visually.

4. PERFORM DTC CONFIRMATION PROCEDURE-II

1. Keep engine idle for at least 5 minutes.
2. Check 1st trip DTC.

P0171, P0174 FUEL INJECTION SYSTEM FUNCTION

[VQ37VHR]

< DTC/CIRCUIT DIAGNOSIS >

Is 1st trip DTC detected?

- YES >> Go to [EC-237, "Diagnosis Procedure"](#).
- NO >> GO TO 5.

5.PERFORM DTC CONFIRMATION PROCEDURE-III

1. Turn ignition switch OFF and wait at least 10 seconds.
2. Start engine.
3. Maintain the following conditions for at least 10 consecutive minutes.
Hold the accelerator pedal as steady as possible.

VHCL SPEED SE	50 - 120 km/h (31 - 75 MPH)
---------------	-----------------------------

CAUTION:

Always drive vehicle at a safe speed.

4. Check 1st trip DTC.

Is 1st trip DTC detected?

- YES >> Go to [EC-237, "Diagnosis Procedure"](#).
- NO >> INSPECTION END

Diagnosis Procedure

INFOID:000000005151786

1.CHECK EXHAUST GAS LEAK

1. Start engine and run it at idle.
2. Listen for an exhaust gas leak before three way catalyst 1.

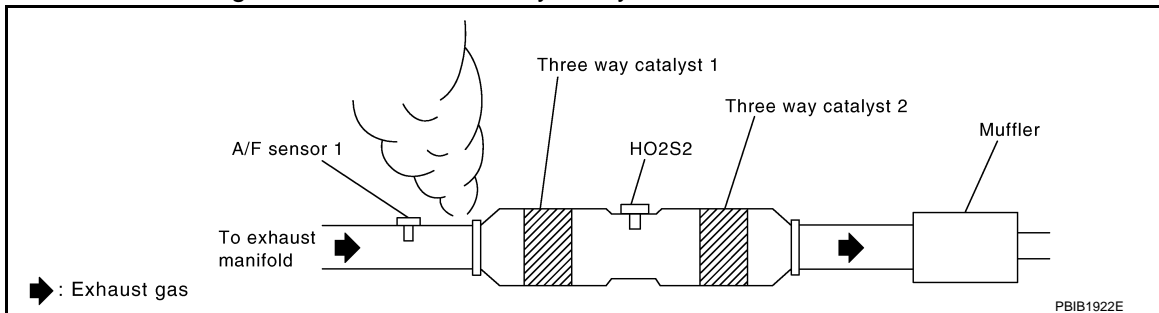

Is exhaust gas leak detected?

- YES >> Repair or replace.
- NO >> GO TO 2.

2.CHECK FOR INTAKE AIR LEAK

1. Listen for an intake air leak after the mass air flow sensor.
2. Check PCV hose connection.

Is intake air leak detected?

- YES >> Repair or replace.
- NO >> GO TO 3.

3.CHECK A/F SENSOR 1 INPUT SIGNAL CIRCUIT

1. Turn ignition switch OFF.
2. Disconnect corresponding A/F sensor 1 harness connector.
3. Disconnect ECM harness connector.
4. Check the continuity between A/F sensor 1 harness connector and ECM harness connector.

DTC	A/F sensor 1			ECM		Continuity
	Bank	Connector	Terminal	Connector	Terminal	
P0171	1	F3	1	F102	57	Existed
			2		61	
P0174	2	F20	1		65	
			2		66	

P0171, P0174 FUEL INJECTION SYSTEM FUNCTION

[VQ37VHR]

< DTC/CIRCUIT DIAGNOSIS >

5. Check the continuity between A/F sensor 1 harness connector and ground, or ECM harness connector and ground.

DTC	A/F sensor 1			Ground	Continuity
	Bank	Connector	Terminal		
P0171	1	F3	1	Ground	Not existed
			2		
P0174	2	F20	1		
			2		

DTC	ECM			Ground	Continuity
	Bank	Connector	Terminal		
P0171	1	F102	57	Ground	Not existed
			61		
P0174	2		65		
			66		

6. Also check harness for short to power.

Is the inspection result normal?

YES >> GO TO 4.

NO >> Repair open circuit, short to ground or short to power in harness or connectors.

4. CHECK FUEL PRESSURE

1. Release fuel pressure to zero. Refer to [EC-607, "Inspection"](#).
2. Install fuel pressure gauge and check fuel pressure. Refer to [EC-607, "Inspection"](#).

At idling: Approximately 350 kPa (3.57 kg/cm², 51 psi)

Is the inspection result normal?

YES >> GO TO 6.

NO >> GO TO 5.

5. DETECT MALFUNCTIONING PART

Check fuel hoses and fuel tubes for clogging.

Is the inspection result normal?

YES >> Replace "fuel filter and fuel pump assembly".

NO >> Repair or replace.

6. CHECK MASS AIR FLOW SENSOR

 **With CONSULT-III**

1. Install all removed parts.
2. Check "MASS AIR FLOW" in "DATA MONITOR" mode with CONSULT-III.
For specification, refer to [EC-612, "Mass Air Flow Sensor"](#).

 **With GST**

1. Install all removed parts.
2. Check mass air flow sensor signal in Service \$01 with GST.
For specification, refer to [EC-612, "Mass Air Flow Sensor"](#).

Is the measurement value within the specification?

YES >> GO TO 7.

NO >> Check connectors for rusted terminals or loose connections in the mass air flow sensor circuit or grounds. Refer to [EC-173, "Diagnosis Procedure"](#).

7. CHECK FUNCTION OF FUEL INJECTOR

 **With CONSULT-III**

1. Start engine.

P0171, P0174 FUEL INJECTION SYSTEM FUNCTION

[VQ37VHR]

< DTC/CIRCUIT DIAGNOSIS >

2. Perform "POWER BALANCE" in "ACTIVE TEST" mode with CONSULT-III.
3. Make sure that each circuit produces a momentary engine speed drop.

⊗ Without CONSULT-III

1. Start engine and let it idle.
2. Listen to each fuel injector operating sound.

Clicking sound should be heard.

Is the inspection result normal?

YES >> GO TO 8.

NO >> Perform trouble diagnosis for FUEL INJECTOR, refer to [EC-492. "Diagnosis Procedure"](#).

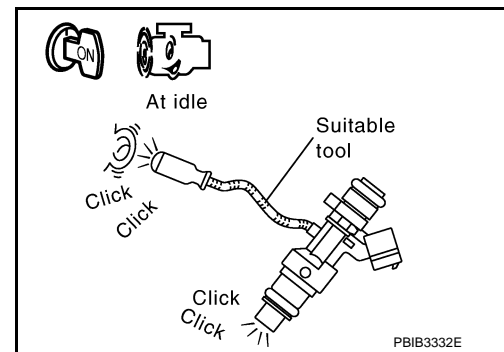

8. CHECK FUEL INJECTOR

1. Turn ignition switch OFF.
2. Confirm that the engine is cooled down and there are no fire hazards near the vehicle.
3. Disconnect all fuel injector harness connectors.
4. Remove fuel tube assembly. Refer to [EM-37. "Removal and Installation"](#).
Keep fuel hose and all fuel injectors connected to fuel tube.
5. For DTC P0171, reconnect fuel injector harness connectors on bank 1.
For DTC P0174, reconnect fuel injector harness connectors on bank 2.
6. Disconnect all ignition coil harness connectors.
7. Prepare pans or saucers under each fuel injector.
8. Crank engine for about 3 seconds.
For DTC P0171, make sure that fuel sprays out from fuel injectors on bank 1.
For DTC P0174, make sure that fuel sprays out from fuel injectors on bank 2.

Fuel should be sprayed evenly for each fuel injector.

Is the inspection result normal?

YES >> GO TO 9.

NO >> Replace fuel injectors from which fuel does not spray out. Always replace O-ring with new ones.

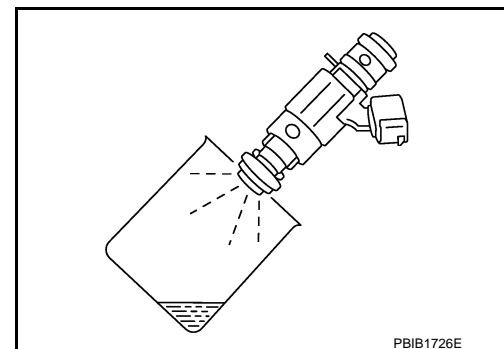

9. CHECK INTERMITTENT INCIDENT

Refer to [GI-36. "Intermittent Incident"](#).

>> INSPECTION END

P0172, P0175 FUEL INJECTION SYSTEM FUNCTION

[VQ37VHR]

< DTC/CIRCUIT DIAGNOSIS >

P0172, P0175 FUEL INJECTION SYSTEM FUNCTION

DTC Logic

INFOID:000000005151787

DTC DETECTION LOGIC

With the Air/Fuel Mixture Ratio Self-Learning Control, the actual mixture ratio can be brought closely to the theoretical mixture ratio based on the mixture ratio feedback signal from A/F sensor 1. The ECM calculates the necessary compensation to correct the offset between the actual and the theoretical ratios.

In case the amount of the compensation value is extremely large (the actual mixture ratio is too rich), the ECM judges the condition as the fuel injection system malfunction and illuminates the MIL (2 trip detection logic).

Sensor	Input signal to ECM	ECM function	Actuator
A/F sensor 1	Density of oxygen in exhaust gas (Mixture ratio feedback signal)	Fuel injection control	Fuel injector

DTC No.	Trouble diagnosis name	DTC detecting condition	Possible cause
P0172	Fuel injection system too rich (bank 1)	• Fuel injection system does not operate properly. • The amount of mixture ratio compensation is too large. (The mixture ratio is too rich.)	• A/F sensor 1 • Fuel injector • Exhaust gas leaks • Incorrect fuel pressure • Mass air flow sensor
P0175	Fuel injection system too rich (bank 2)		

DTC CONFIRMATION PROCEDURE

1. PRECONDITIONING

If DTC Confirmation Procedure has been previously conducted, always perform the following procedure before conducting the next test.

1. Turn ignition switch OFF and wait at least 10 seconds.
2. Turn ignition switch ON.
3. Turn ignition switch OFF and wait at least 10 seconds.

>> GO TO 2.

2. PERFORM DTC CONFIRMATION PROCEDURE-I

1. Clear the mixture ratio self-learning value. Refer to [EC-22, "MIXTURE RATIO SELF-LEARNING VALUE CLEAR : Special Repair Requirement"](#).
2. Start engine.

Is it difficult to start engine?

- YES >> GO TO 3.
NO >> GO TO 4.

3. RESTART ENGINE

If it is difficult to start engine, the fuel injection system has a malfunction, too.
Crank engine while depressing accelerator pedal.

NOTE:

When depressing accelerator pedal three fourths (3/4) or more, the control system does not start the engine. Do not depress accelerator pedal too much.

Does engine start?

- YES >> Go to [EC-241, "Diagnosis Procedure"](#).
NO >> Remove spark plugs and check for fouling, etc.

4. PERFORM DTC CONFIRMATION PROCEDURE-II

1. Keep engine idle for at least 10 minutes.
2. Check 1st trip DTC.

Is 1st trip DTC detected?

- YES >> Go to [EC-241, "Diagnosis Procedure"](#).
NO >> GO TO 5.

P0172, P0175 FUEL INJECTION SYSTEM FUNCTION

< DTC/CIRCUIT DIAGNOSIS >

[VQ37VHR]

5. PERFORM DTC CONFIRMATION PROCEDURE-III

1. Turn ignition switch OFF and wait at least 10 seconds.
2. Start engine.
3. Maintain the following conditions for at least 10 consecutive minutes..
Hold the accelerator pedal as steady as possible.

VHCL SPEED SE	50 - 120 km/h (31 - 75 MPH)
---------------	-----------------------------

CAUTION:

Always drive vehicle at a safe speed.

4. Check 1st trip DTC.

Is 1st trip DTC detected?

- YES >> Go to [EC-241. "Diagnosis Procedure"](#).
NO >> INSPECTION END

Diagnosis Procedure

INFOID:000000005151788

1. CHECK EXHAUST GAS LEAK

1. Start engine and run it at idle.
2. Listen for an exhaust gas leak before three way catalyst 1.

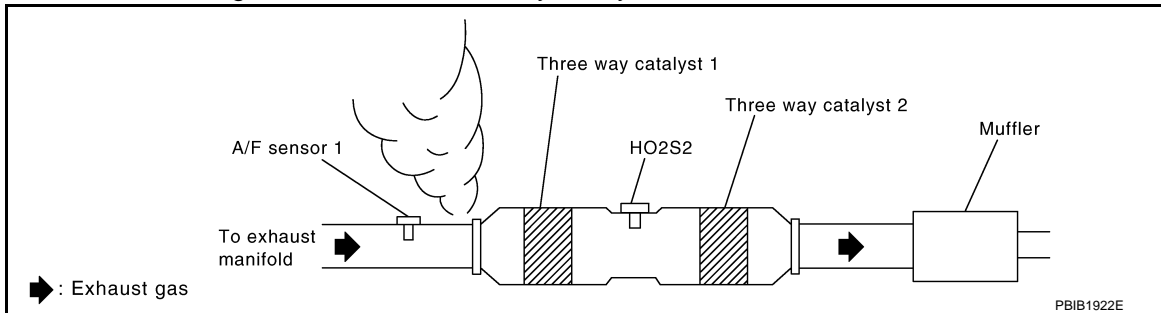

Is exhaust gas leak detected?

- YES >> Repair or replace.
NO >> GO TO 2.

2. CHECK FOR INTAKE AIR LEAK

Listen for an intake air leak after the mass air flow sensor.

Is intake air leak detected?

- YES >> Repair or replace.
NO >> GO TO 3.

3. CHECK A/F SENSOR 1 INPUT SIGNAL CIRCUIT

1. Turn ignition switch OFF.
2. Disconnect corresponding A/F sensor 1 harness connector.
3. Disconnect ECM harness connector.
4. Check the continuity between A/F sensor 1 harness connector and ECM harness connector.

DTC	A/F sensor 1			ECM		Continuity
	Bank	Connector	Terminal	Connector	Terminal	
P0172	1	F3	1	F102	57	Existed
			2		61	
P0175	2	F20	1		65	
			2		66	

5. Check the continuity between A/F sensor 1 harness connector and ground, or ECM harness connector and ground.

P0172, P0175 FUEL INJECTION SYSTEM FUNCTION

[VQ37VHR]

< DTC/CIRCUIT DIAGNOSIS >

DTC	A/F sensor 1			Ground	Continuity
	Bank	Connector	Terminal		
P0172	1	F3	1	Ground	Not existed
			2		
P0175	2	F20	1		
			2		

DTC	ECM			Ground	Continuity
	Bank	Connector	Terminal		
P0172	1	F102	57	Ground	Not existed
			61		
P0175	2		65		
			66		

6. Also check harness for short to power.

Is the inspection result normal?

YES >> GO TO 4.

NO >> Repair open circuit, short to ground or short to power in harness or connectors.

4. CHECK FUEL PRESSURE

1. Release fuel pressure to zero. Refer to [EC-607, "Inspection"](#).
2. Install fuel pressure gauge and check fuel pressure. Refer to [EC-607, "Inspection"](#).

At idling: Approximately 350 kPa (3.57 kg/cm², 51 psi)

Is the inspection result normal?

YES >> GO TO 5.

NO >> Replace "fuel filter and fuel pump assembly".

5. CHECK MASS AIR FLOW SENSOR

 **With CONSULT-III**

1. Install all removed parts.
2. Check "MASS AIR FLOW" in "DATA MONITOR" mode with CONSULT-III.
For specification, refer to [EC-612, "Mass Air Flow Sensor"](#).

 **With GST**

1. Install all removed parts.
2. Check mass air flow sensor signal in "Service \$01" with GST.
For specification, refer to [EC-612, "Mass Air Flow Sensor"](#).

Is the measurement value within the specification?

YES >> GO TO 6.

NO >> Check connectors for rusted terminals or loose connections in the mass air flow sensor circuit or grounds. Refer to [EC-173, "Diagnosis Procedure"](#).

6. CHECK FUNCTION OF FUEL INJECTOR

 **With CONSULT-III**

1. Start engine.
2. Perform "POWER BALANCE" in "ACTIVE TEST" mode with CONSULT-III.
3. Make sure that each circuit produces a momentary engine speed drop.

 **Without CONSULT-III**

1. Start engine and let it idle.

P0172, P0175 FUEL INJECTION SYSTEM FUNCTION

[VQ37VHR]

< DTC/CIRCUIT DIAGNOSIS >

- Listen to each fuel injector operating sound.

Clicking sound should be heard.

Is the inspection result normal?

YES >> GO TO 7.

NO >> Perform trouble diagnosis for FUEL INJECTOR, refer to [EC-492. "Diagnosis Procedure"](#).

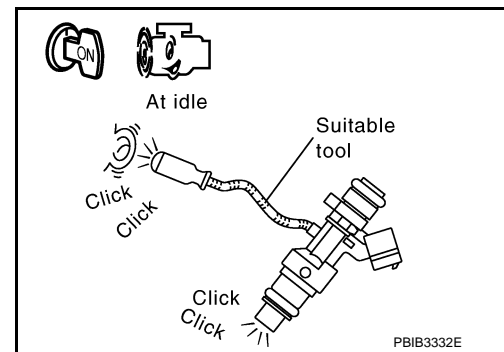

7. CHECK FUEL INJECTOR

- Remove fuel injector assembly. Refer to [EM-37. "Removal and Installation"](#).
Keep fuel hose and all fuel injectors connected to fuel tube.
- Confirm that the engine is cooled down and there are no fire hazards near the vehicle.
- Disconnect all fuel injector harness connectors.
- Disconnect all ignition coil harness connectors.
- Prepare pans or saucers under each fuel injector.
- Crank engine for about 3 seconds.
Make sure fuel that does not drip from fuel injector.

Is the inspection result normal?

YES >> GO TO 8.

NO >> Replace the fuel injectors from which fuel is dripping. Always replace O-ring with new one.

8. CHECK INTERMITTENT INCIDENT

Refer to [GI-36. "Intermittent Incident"](#).

>> INSPECTION END

P0181 FTT SENSOR

Description

INFOID:000000005151789

The fuel tank temperature sensor is used to detect the fuel temperature inside the fuel tank. The sensor modifies a voltage signal from the ECM. The modified signal returns to the ECM as the fuel temperature input. The sensor uses a thermistor which is sensitive to the change in temperature. The electrical resistance of the thermistor decreases as temperature increases.

<Reference data>

Fluid temperature [°C (°F)]	Voltage* (V)	Resistance (kΩ)
20 (68)	3.5	2.3 - 2.7
50 (122)	2.2	0.79 - 0.90

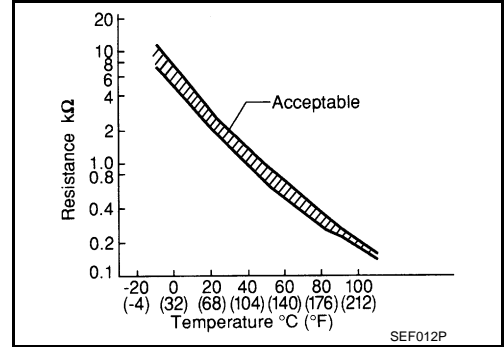

*: These data are reference values and are measured between ECM terminals 106 (Fuel tank temperature sensor) and 128 (ECM ground).

DTC Logic

INFOID:000000005151790

DTC DETECTION LOGIC

DTC No.	Trouble diagnosis name	DTC detecting condition	Possible cause
P0181	Fuel tank temperature sensor circuit range/performance	Rationally incorrect voltage from the sensor is sent to ECM, compared with the voltage signals from engine coolant temperature sensor and intake air temperature sensor.	<ul style="list-style-type: none"> • Harness or connectors (The sensor circuit is open or shorted) • Fuel tank temperature sensor

DTC CONFIRMATION PROCEDURE

1. PRECONDITIONING

If DTC Confirmation Procedure has been previously conducted, always perform the following procedure before conducting the next test.

1. Turn ignition switch OFF and wait at least 10 seconds.
2. Turn ignition switch ON.
3. Turn ignition switch OFF and wait at least 10 seconds.

>> GO TO 2.

2. PERFORM DTC CONFIRMATION PROCEDURE-I

1. Turn ignition switch ON and wait at least 10 seconds.
2. Check 1st trip DTC.

Is 1st trip DTC detected?

- YES >> Go to [EC-245, "Diagnosis Procedure"](#).
- NO >> GO TO 3.

3. CHECK ENGINE COOLANT TEMPERATURE

1. Select "COOLAN TEMP/S" in "DATA MONITOR" with CONSULT-III.
2. Check "COOLAN TEMP/S" value.

"COOLAN TEMP/S" less than 60°C (140°F)?

- YES >> INSPECTION END
- NO >> GO TO 4.

4. PERFORM DTC CONFIRMATION PROCEDURE-II

1. Cool engine down until "COOLAN TEMP/S" is less than 60°C (140°F).
2. Wait at least 10 seconds.

P0181 FTT SENSOR

[VQ37VHR]

< DTC/CIRCUIT DIAGNOSIS >

3. Check 1st trip DTC.

Is 1st trip DTC detected?

YES >> Go to [EC-245, "Diagnosis Procedure"](#).

NO >> INSPECTION END

Diagnosis Procedure

INFOID:000000005151791

1. CHECK GROUND CONNECTION

1. Turn ignition switch OFF.

2. Check ground connection M95. Refer to Ground Inspection in [GI-39, "Circuit Inspection"](#).

Is the inspection result normal?

YES >> GO TO 2.

NO >> Repair or replace ground connection.

2. CHECK DTC WITH "UNIFIED METER AND A/C AMP."

Refer to [MWI-37, "CONSULT-III Function \(METER/M&A\)"](#).

Is the inspection result normal?

YES >> GO TO 3.

NO >> Go to [MWI-53, "Component Function Check"](#).

3. CHECK FUEL TANK TEMPERATURE SENSOR POWER SUPPLY CIRCUIT

1. Turn ignition switch OFF.

2. Disconnect "fuel level sensor unit and fuel pump" harness connector.

3. Turn ignition switch ON.

4. Check the voltage between "fuel level sensor unit and fuel pump" harness connector and ground.

Fuel level sensor unit and fuel pump		Ground	Voltage (V)
Connector	Terminal		
B22	4	Ground	Approx. 5

Is the inspection result normal?

YES >> GO TO 5.

NO >> GO TO 4.

4. DETECT MALFUNCTIONING PART

Check the following.

- Harness connectors M7, B1
- Harness for open or short between ECM and "fuel level sensor unit and fuel pump"

>> Repair open circuit, short to ground or short to power in harness or connector.

5. CHECK FUEL TANK TEMPERATURE SENSOR GROUND CIRCUIT FOR OPEN AND SHORT

1. Turn ignition switch OFF.

2. Disconnect "unified meter and A/C amp." harness connector.

3. Check the continuity between "fuel level sensor unit and fuel pump" harness connector and "unified meter and A/C amp." harness connector.

Fuel level sensor unit and fuel pump		Unified meter and A/C amp.		Continuity
Connector	Terminal	Connector	Terminal	
B22	5	M67	58	Existed

4. Also check harness for short to ground and short to power.

Is the inspection result normal?

YES >> GO TO 7.

NO >> GO TO 6.

P0181 FTT SENSOR

< DTC/CIRCUIT DIAGNOSIS >

[VQ37VHR]

6. DETECT MALFUNCTIONING PART

Check the following.

- Harness connectors M7, B1
- Harness for open or short between “fuel level sensor unit and fuel pump” and “unified meter and A/C amp.”

>> Repair open circuit, short to ground or short to power in harness or connector.

7. CHECK FUEL TANK TEMPERATURE SENSOR

Refer to [EC-246. "Component Inspection"](#).

Is the inspection result normal?

YES >> GO TO 8.

NO >> Replace “fuel level sensor unit and fuel pump”.

8. CHECK INTERMITTENT INCIDENT

Refer to [GI-36. "Intermittent Incident"](#).

>> INSPECTION END

Component Inspection

INFOID:000000005151792

1. CHECK FUEL TANK TEMPERATURE SENSOR

1. Turn ignition switch OFF.
2. Disconnect “fuel level sensor unit and fuel pump” harness connector.
3. Remove fuel level sensor unit.
4. Check resistance between “fuel level sensor unit and fuel pump” terminals by heating with hot water as shown in the figure.

Terminals	Condition	Resistance (k Ω)
4 and 5	20 (68)	2.3 - 2.7
	50 (122)	0.79 - 0.90

Is the inspection result normal?

YES >> INSPECTION END

NO >> Replace “fuel level sensor unit and fuel pump”.

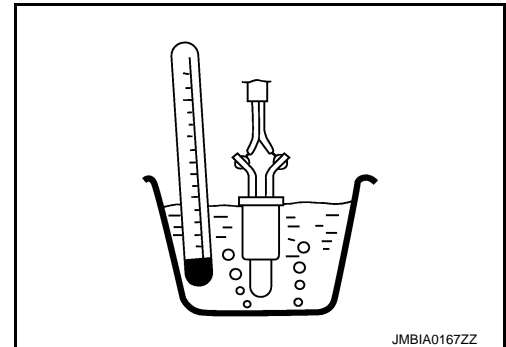

P0182, P0183 FTT SENSOR

Description

INFOID:000000005151793

The fuel tank temperature sensor is used to detect the fuel temperature inside the fuel tank. The sensor modifies a voltage signal from the ECM. The modified signal returns to the ECM as the fuel temperature input. The sensor uses a thermistor which is sensitive to the change in temperature. The electrical resistance of the thermistor decreases as temperature increases.

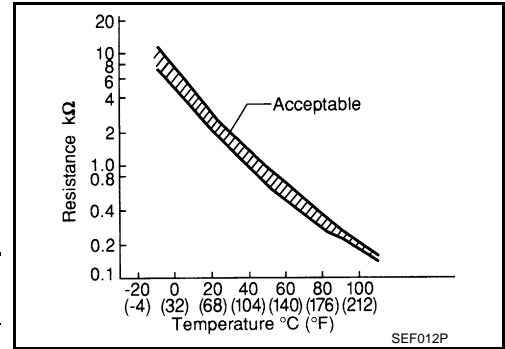

<Reference data>

Fluid temperature [°C (°F)]	Voltage* (V)	Resistance (kΩ)
20 (68)	3.5	2.3 - 2.7
50 (122)	2.2	0.79 - 0.90

*: These data are reference values and are measured between ECM terminals 106 (Fuel tank temperature sensor) and 128 (ECM ground).

DTC Logic

INFOID:000000005151794

DTC DETECTION LOGIC

DTC No.	Trouble diagnosis name	DTC detecting condition	Possible cause
P0182	Fuel tank temperature sensor circuit low input	An excessively low voltage from the sensor is sent to ECM.	<ul style="list-style-type: none"> • Harness or connectors (The sensor circuit is open or shorted.) • Fuel tank temperature sensor
P0183	Fuel tank temperature sensor circuit high input	An excessively high voltage from the sensor is sent to ECM.	

DTC CONFIRMATION PROCEDURE

1. PRECONDITIONING

If DTC Confirmation Procedure has been previously conducted, always perform the following procedure before conducting the next test.

1. Turn ignition switch OFF and wait at least 10 seconds.
2. Turn ignition switch ON.
3. Turn ignition switch OFF and wait at least 10 seconds.

>> GO TO 2.

2. PERFORM DTC CONFIRMATION PROCEDURE

1. Turn ignition switch ON and wait at least 5 seconds.
2. Check 1st trip DTC.

Is 1st trip DTC detected?

- YES >> Go to [EC-247. "Diagnosis Procedure"](#).
- NO >> INSPECTION END

Diagnosis Procedure

INFOID:000000005151795

1. CHECK GROUND CONNECTION

1. Turn ignition switch OFF.
2. Check ground connection M95. Refer to Ground Inspection in [GI-39. "Circuit Inspection"](#).

Is the inspection result normal?

- YES >> GO TO 2.
- NO >> Repair or replace ground connection.

2. CHECK DTC WITH "UNIFIED METER AND A/C AMP."

< DTC/CIRCUIT DIAGNOSIS >

Refer to [MWI-37. "CONSULT-III Function \(METER/M&A\)".](#)

Is the inspection result normal?

- YES >> GO TO 3.
- NO >> Go to [MWI-53. "Component Function Check".](#)

3.CHECK FUEL TANK TEMPERATURE SENSOR POWER SUPPLY CIRCUIT

1. Turn ignition switch OFF.
2. Disconnect "fuel level sensor unit and fuel pump" harness connector.
3. Turn ignition switch ON.
4. Check the voltage between "fuel level sensor unit and fuel pump" harness connector and ground.

Fuel level sensor unit and fuel pump		Ground	Voltage (V)
Connector	Terminal		
B22	4	Ground	Approx. 5

Is the inspection result normal?

- YES >> GO TO 5.
- NO >> GO TO 4.

4.DETECT MALFUNCTIONING PART

Check the following.

- Harness connectors M7, B1
- Harness for open or short between ECM and "fuel level sensor unit and fuel pump"

>> Repair open circuit, short to ground or short to power in harness or connector.

5.CHECK FUEL TANK TEMPERATURE SENSOR GROUND CIRCUIT FOR OPEN AND SHORT

1. Turn ignition switch OFF.
2. Disconnect "unified meter and A/C amp." harness connector.
3. Check the continuity between "fuel level sensor unit and fuel pump" harness connector and "unified meter and A/C amp." harness connector.

Fuel level sensor unit and fuel pump		Unified meter and A/C amp.		Continuity
Connector	Terminal	Connector	Terminal	
B22	5	M67	58	Existed

4. Also check harness for short to ground and short to power.

Is the inspection result normal?

- YES >> GO TO 7.
- NO >> GO TO 6.

6.DETECT MALFUNCTIONING PART

Check the following.

- Harness connectors M7, B1
- Harness for open or short between "fuel level sensor unit and fuel pump" and "unified meter and A/C amp."

>> Repair open circuit, short to ground or short to power in harness or connector.

7.CHECK FUEL TANK TEMPERATURE SENSOR

Refer to [EC-249. "Component Inspection".](#)

Is the inspection result normal?

- YES >> GO TO 8.
- NO >> Replace "fuel level sensor unit and fuel pump".

8.CHECK INTERMITTENT INCIDENT

P0182, P0183 FTT SENSOR

[VQ37VHR]

< DTC/CIRCUIT DIAGNOSIS >

Refer to [GI-36. "Intermittent Incident"](#).

>> INSPECTION END

Component Inspection

INFOID:000000005151796

A

EC

1. CHECK FUEL TANK TEMPERATURE SENSOR

1. Turn ignition switch OFF.
2. Disconnect "fuel level sensor unit and fuel pump" harness connector.
3. Remove fuel level sensor unit.
4. Check resistance between "fuel level sensor unit and fuel pump" terminals by heating with hot water as shown in the figure.

Terminals	Condition		Resistance (k Ω)
4 and 5	Temperature [$^{\circ}$ C ($^{\circ}$ F)]	20 (68)	2.3 - 2.7
		50 (122)	0.79 - 0.90

Is the inspection result normal?

- YES >> INSPECTION END
NO >> Replace "fuel level sensor unit and fuel pump".

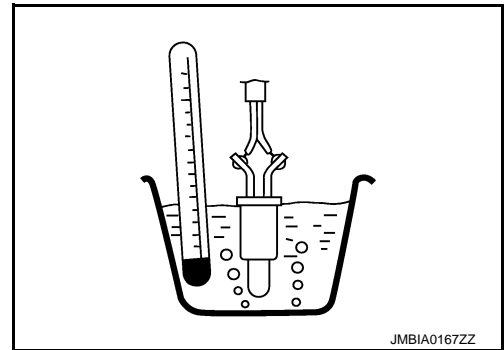

C

D

E

F

G

H

I

J

K

L

M

N

O

P

P0196 EOT SENSOR

Description

INFOID:000000005151797

The engine oil temperature sensor is used to detect the engine oil temperature. The sensor modifies a voltage signal from the ECM. The modified signal returns to the ECM as the engine oil temperature input. The sensor uses a thermistor which is sensitive to the change in temperature. The electrical resistance of the thermistor decreases as temperature increases.

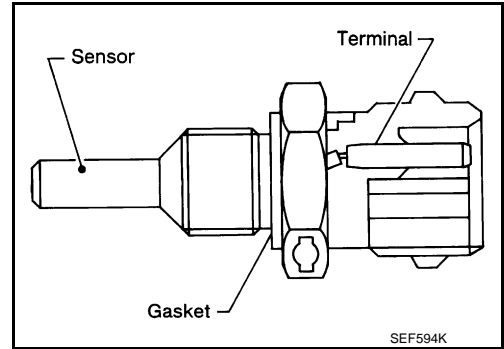

<Reference data>

Engine oil temperature [°C (°F)]	Voltage* (V)	Resistance (kΩ)
-10 (14)	4.4	7.0 - 11.4
20 (68)	3.5	2.1 - 2.9
50 (122)	2.2	0.68 - 1.00
90 (194)	0.9	0.236 - 0.260
110 (230)	0.6	0.143 - 0.153

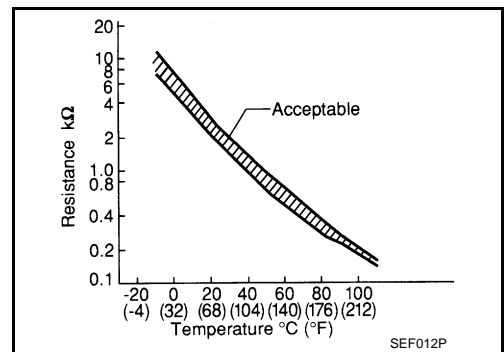

*: These data are reference values and are measured between ECM terminals 78 (Engine oil temperature sensor) and 84 (Sensor ground).

DTC Logic

INFOID:000000005151798

DTC DETECTION LOGIC

NOTE:

If DTC P0196 is displayed with P0197 or P0198, first perform the trouble diagnosis for DTC P0197 or P0198. Refer to [EC-253, "DTC Logic"](#).

DTC No.	Trouble diagnosis name	DTC detecting condition	Possible cause
P0196	Engine oil temperature sensor range/performance	Rationally incorrect voltage from the sensor is sent to ECM, compared with the voltage signals from engine coolant temperature sensor and intake air temperature sensor.	<ul style="list-style-type: none"> • Harness or connectors (The sensor circuit is open or shorted) • Engine oil temperature sensor

DTC CONFIRMATION PROCEDURE

1. PRECONDITIONING

If DTC Confirmation Procedure has been previously conducted, always perform the following procedure before conducting the next test.

1. Turn ignition switch OFF and wait at least 10 seconds.
2. Turn ignition switch ON.
3. Turn ignition switch OFF and wait at least 10 seconds.

TESTING CONDITION:

Before performing the following procedure, confirm that battery voltage is more than 11 V at idle.

>> GO TO 2.

2. PERFORM DTC CONFIRMATION PROCEDURE-I

1. Start engine and warm it up to normal operating temperature.
2. Turn ignition switch OFF and wait at least 10 seconds.

P0196 EOT SENSOR

[VQ37VHR]

< DTC/CIRCUIT DIAGNOSIS >

3. Turn ignition switch ON.
4. Turn ignition switch OFF and wait at least 10 seconds.
5. Start engine and let it idle for 5 minutes and 10 seconds.
6. Check 1st trip DTC.

Is 1st trip DTC detected?

- YES >> [EC-251, "Diagnosis Procedure"](#).
NO >> GO TO 3.

3.PERFORM DTC CONFIRMATION PROCEDURE-II

1. Select "DATA MONITOR" mode with CONSULT-III.
2. Check that "COOLAN TEMP/S" indicates above 80°C (176°F).
If it is above 80°C (176°F), go to the following steps.
If it is below 80°C (176°F), warm engine up until "COOLAN TEMP/S" indicates more than 80°C (176°F).
Then perform the following steps.
3. Turn ignition switch OFF and soak the vehicle in a cool place.
4. Turn ignition switch ON.
5. Turn ignition switch OFF and wait at least 10 seconds.
6. Turn ignition switch ON.

NOTE:

Do not turn ignition switch OFF until step 10.

7. Select "DATA MONITOR" mode with CONSULT-III.
8. Check the following.

COOLAN TEMP/S	Below 40°C (104°F)
INT/A TEMP SE	Below 40°C (104°F)
Difference between "COOLAN TEMP/S" and "INT/A TEMP SE"	Within 6°C (11°F)

If they are within the specified range, perform the following steps.

If they are out of the specified range, soak the vehicle to meet the above conditions. Then perform the following steps.

NOTE:

- **Do not turn ignition switch OFF.**
- **If it is supposed to need a long period of time, do not deplete the battery.**

9. Start engine and let it idle for 5 minutes.
10. Check 1st trip DTC.

Is 1st trip DTC detected?

- YES >> [EC-251, "Diagnosis Procedure"](#).
NO >> INSPECTION END

Diagnosis Procedure

INFOID:000000005151799

1.CHECK GROUND CONNECTION

1. Turn ignition switch OFF.
2. Check ground connection M95. Refer to Ground Inspection in [GI-39, "Circuit Inspection"](#).

Is the inspection result normal?

- YES >> GO TO 2.
NO >> Repair or replace ground connection.

2.CHECK ENGINE OIL TEMPERATURE SENSOR

Refer to [EC-252, "Component Inspection"](#).

Is the inspection result normal?

- YES >> GO TO 3.
NO >> Replace engine oil temperature sensor.

3.CHECK INTERMITTENT INCIDENT

Refer to [GI-36, "Intermittent Incident"](#).

>> INSPECTION END

Component Inspection

INFOID:000000005151800

1. CHECK ENGINE OIL TEMPERATURE SENSOR

1. Turn ignition switch OFF.
2. Disconnect engine oil temperature sensor harness connector.
3. Remove engine oil temperature sensor.
4. Check resistance between engine oil temperature sensor terminals by heating with hot water as shown in the figure.

Terminals	Condition	Resistance (kΩ)	
1 and 2	Temperature [°C (°F)]	20 (68)	2.1 - 2.9
		50 (122)	0.68 - 1.00
		90 (194)	0.236 - 0.260

Is the inspection result normal?

- YES >> INSPECTION END
 NO >> Replace engine oil temperature sensor.

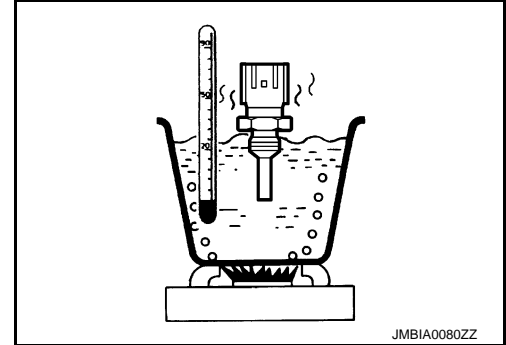

P0197, P0198 EOT SENSOR

< DTC/CIRCUIT DIAGNOSIS >

[VQ37VHR]

P0197, P0198 EOT SENSOR

Description

INFOID:000000005151801

The engine oil temperature sensor is used to detect the engine oil temperature. The sensor modifies a voltage signal from the ECM. The modified signal returns to the ECM as the engine oil temperature input. The sensor uses a thermistor which is sensitive to the change in temperature. The electrical resistance of the thermistor decreases as temperature increases.

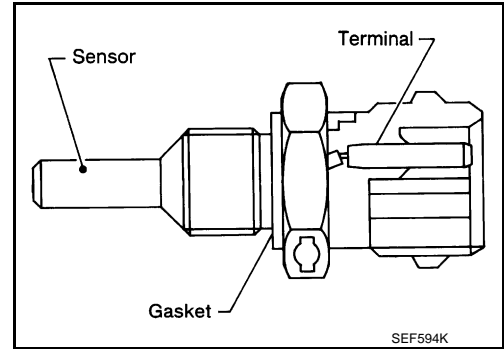

<Reference data>

Engine oil temperature [°C (°F)]	Voltage* (V)	Resistance (kΩ)
-10 (14)	4.4	7.0 - 11.4
20 (68)	3.5	2.1 - 2.9
50 (122)	2.2	0.68 - 1.00
90 (194)	0.9	0.236 - 0.260
110 (230)	0.6	0.143 - 0.153

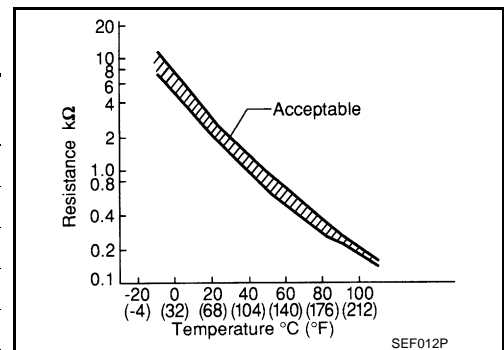

*: These data are reference values and are measured between ECM terminals 78 (Engine oil temperature sensor) and 84 (Sensor ground).

DTC Logic

INFOID:000000005151802

DTC DETECTION LOGIC

DTC No.	Trouble Diagnosis Name	DTC Detecting Condition	Possible Cause
P0197	Engine oil temperature sensor circuit low input	An excessively low voltage from the sensor is sent to ECM.	<ul style="list-style-type: none"> • Harness or connectors (The sensor circuit is open or shorted.) • Engine oil temperature sensor
P0198	Engine oil temperature sensor circuit high input	An excessively high voltage from the sensor is sent to ECM.	

DTC CONFIRMATION PROCEDURE

1. PRECONDITIONING

If DTC Confirmation Procedure has been previously conducted, always perform the following procedure before conducting the next test.

1. Turn ignition switch OFF and wait at least 10 seconds.
2. Turn ignition switch ON.
3. Turn ignition switch OFF and wait at least 10 seconds.

>> GO TO 2.

2. PERFORM DTC CONFIRMATION PROCEDURE

1. Start engine and wait at least 5 seconds.
2. Check 1st trip DTC.

Is 1st trip DTC detected?

P0197, P0198 EOT SENSOR

[VQ37VHR]

< DTC/CIRCUIT DIAGNOSIS >

- YES >> Go to [EC-254, "Diagnosis Procedure"](#).
NO >> INSPECTION END

Diagnosis Procedure

INFOID:000000005151803

1. CHECK GROUND CONNECTION

1. Turn ignition switch OFF.
2. Check ground connection M95. Refer to Ground Inspection in [GI-39, "Circuit Inspection"](#).

Is the inspection result normal?

- YES >> GO TO 2.
NO >> Repair or replace ground connection.

2. CHECK EOT SENSOR POWER SUPPLY CIRCUIT

1. Disconnect engine oil temperature (EOT) sensor harness connector.
2. Turn ignition switch ON.
3. Check the voltage between EOT sensor harness connector and ground.

EOT sensor		Ground	Voltage (V)
Connector	Terminal		
F38	1	Ground	Approx. 5

Is the inspection result normal?

- YES >> GO TO 3.
NO >> Repair open circuit, short to ground or short to power in harness or connectors.

3. CHECK EOT SENSOR GROUND CIRCUIT FOR OPEN AND SHORT

1. Turn ignition switch OFF.
2. Disconnect ECM harness connector.
3. Check the continuity between EOT sensor harness connector and ECM harness connector.

EOT sensor		ECM		Continuity
Connector	Terminal	Connector	Terminal	
F38	2	F102	84	Existed

4. Also check harness for short to ground and short to power.

Is the inspection result normal?

- YES >> GO TO 4.
NO >> Repair open circuit, short to ground or short to power in harness or connectors.

4. CHECK ENGINE OIL TEMPERATURE SENSOR

Refer to [EC-254, "Component Inspection"](#).

Is the inspection result normal?

- YES >> GO TO 5.
NO >> Replace engine oil temperature sensor.

5. CHECK INTERMITTENT INCIDENT

Refer to [GI-36, "Intermittent Incident"](#).

>> INSPECTION END

Component Inspection

INFOID:000000005151804

1. CHECK ENGINE OIL TEMPERATURE SENSOR

1. Turn ignition switch OFF.
2. Disconnect engine oil temperature sensor harness connector.
3. Remove engine oil temperature sensor.

P0197, P0198 EOT SENSOR

[VQ37VHR]

< DTC/CIRCUIT DIAGNOSIS >

4. Check resistance between engine oil temperature sensor terminals by heating with hot water as shown in the figure.

Terminals	Condition		Resistance (k Ω)
1 and 2	Temperature °C (°F)]	20 (68)	2.1 - 2.9
		50 (122)	0.68 - 1.00
		90 (194)	0.236 - 0.260

Is the inspection result normal?

YES >> INSPECTION END

NO >> Replace engine oil temperature sensor.

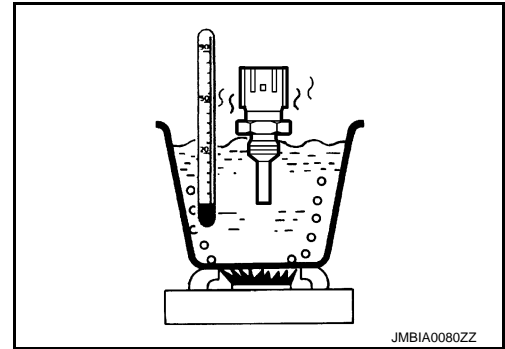

A

EC

C

D

E

F

G

H

I

J

K

L

M

N

O

P

P0222, P0223, P2132, P2133 TP SENSOR

< DTC/CIRCUIT DIAGNOSIS >

[VQ37VHR]

P0222, P0223, P2132, P2133 TP SENSOR

Description

INFOID:000000005151805

Electric throttle control actuator consists of throttle control motor, throttle position sensor, etc. The throttle position sensor responds to the throttle valve movement.

The throttle position sensor has two sensors. These sensors are a kind of potentiometer which transform the throttle valve position into output voltage, and emit the voltage signals to the ECM. The ECM judges the current opening angle of the throttle valve from these signals and controls the throttle valve opening angle properly in response to driving condition via the throttle control motor.

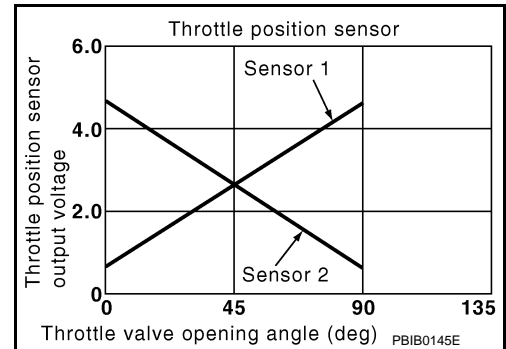

DTC Logic

INFOID:000000005151806

DTC DETECTION LOGIC

NOTE:

If DTC P0222, P0223, P2132 or P2133 is displayed with DTC P0643, first perform the trouble diagnosis for DTC P0643. Refer to [EC-364, "DTC Logic"](#).

DTC No.	Trouble diagnosis name	DTC detecting condition	Possible cause
P0222	Throttle position sensor 1 (bank 1) circuit low input	An excessively low voltage from the TP sensor 1 is sent to ECM.	<ul style="list-style-type: none"> • Harness or connectors (TP sensor 1 circuit is open or shorted.) • Electric throttle control actuator (TP sensor 1)
P0223	Throttle position sensor 1 (bank 1) circuit high input	An excessively high voltage from the TP sensor 1 is sent to ECM.	
P2132	Throttle position sensor 1 (bank 2) circuit low input	An excessively low voltage from the TP sensor 1 is sent to ECM.	
P2133	Throttle position sensor 1 (bank 2) circuit high input	An excessively high voltage from the TP sensor 1 is sent to ECM.	

DTC CONFIRMATION PROCEDURE

1. PRECONDITIONING

If DTC Confirmation Procedure has been previously conducted, always perform the following procedure before conducting the next test.

1. Turn ignition switch OFF and wait at least 10 seconds.
2. Turn ignition switch ON.
3. Turn ignition switch OFF and wait at least 10 seconds.

TESTING CONDITION:

Before performing the following procedure, confirm that battery voltage is more than 10 V at idle.

>> GO TO 2.

2. PERFORM DTC CONFIRMATION PROCEDURE

1. Start engine and let it idle for 1 second.
2. Check DTC.

Is DTC detected?

- YES >> Go to [EC-257, "Diagnosis Procedure"](#).
 NO >> INSPECTION END

P0222, P0223, P2132, P2133 TP SENSOR

< DTC/CIRCUIT DIAGNOSIS >

[VQ37VHR]

Diagnosis Procedure

INFOID:000000005151807

1. CHECK GROUND CONNECTION

1. Turn ignition switch OFF.
2. Check ground connection M95. Refer to Ground Inspection in [GI-39. "Circuit Inspection"](#).

Is the inspection result normal?

- YES >> GO TO 2.
NO >> Repair or replace ground connection.

2. CHECK THROTTLE POSITION SENSOR 1 POWER SUPPLY CIRCUIT

1. Disconnect electric throttle control actuator harness connector.
2. Turn ignition switch ON.
3. Check the voltage between electric throttle control actuator harness connector and ground.

DTC	Electric throttle control actuator			Ground	Voltage (V)
	Bank	Connector	Terminal		
P0222, P0223	1	F6	6	Ground	Approx. 5
P2132, P2133	2	F27	1		

Is the inspection result normal?

- YES >> GO TO 3.
NO >> Repair open circuit, short to ground or short to power in harness or connectors.

3. CHECK THROTTLE POSITION SENSOR 1 GROUND CIRCUIT FOR OPEN AND SHORT

1. Turn ignition switch OFF.
2. Disconnect ECM harness connector.
3. Check the continuity between electric throttle control actuator harness connector and ECM harness connector.

DTC	Electric throttle control actuator			ECM		Continuity
	Bank	Connector	Terminal	Connector	Terminal	
P0222, P0223	1	F6	3	F101	40	Existed
P2132, P2133	2	F27	4		48	

4. Also check harness for short to ground and short to power.

Is the inspection result normal?

- YES >> GO TO 4.
NO >> Repair open circuit, short to ground or short to power in harness or connectors.

4. CHECK THROTTLE POSITION SENSOR 1 INPUT SIGNAL CIRCUIT FOR OPEN AND SHORT

1. Check the continuity between electric throttle control actuator harness connector and ECM harness connector.

DTC	Electric throttle control actuator			ECM		Continuity
	Bank	Connector	Terminal	Connector	Terminal	
P0222, P0223	1	F6	4	F101	30	Existed
P2132, P2133	2	F27	2		31	

2. Also check harness for short to ground and short to power.

Is the inspection result normal?

- YES >> GO TO 5.
NO >> Repair open circuit, short to ground or short to power in harness or connectors.

5. CHECK THROTTLE POSITION SENSOR

Refer to [EC-258. "Component Inspection"](#).

P0222, P0223, P2132, P2133 TP SENSOR

[VQ37VHR]

< DTC/CIRCUIT DIAGNOSIS >

Is the inspection result normal?

- YES >> GO TO 7.
- NO >> GO TO 6.

6. REPLACE ELECTRIC THROTTLE CONTROL ACTUATOR

1. Replace malfunctioning electric throttle control actuator.
2. Go to [EC-258, "Special Repair Requirement"](#).

>> INSPECTION END

7. CHECK INTERMITTENT INCIDENT

Refer to [GI-36, "Intermittent Incident"](#).

>> INSPECTION END

Component Inspection

INFOID:000000005151808

1. CHECK THROTTLE POSITION SENSOR

1. Turn ignition switch OFF.
2. Reconnect all harness connectors disconnected.
3. Perform [EC-18, "THROTTLE VALVE CLOSED POSITION LEARNING : Special Repair Requirement"](#).
4. Turn ignition switch ON.
5. Set selector lever to D (A/T) or 1st (M/T) position.
6. Check the voltage between ECM harness connector terminals under the following conditions.

ECM			Condition	Voltage (V)
Connector	+	-		
	Terminal			
F101	30 [TP sensor 1 (bank 1)]	40	Fully released	More than 0.36
			Fully depressed	Less than 4.75
	31 [TP sensor 1 (bank 2)]	48	Fully released	More than 0.36
			Fully depressed	Less than 4.75
	34 [TP sensor 2 (bank 1)]	40	Fully released	Less than 4.75
			Fully depressed	More than 0.36
	35 [TP sensor 2 (bank 2)]	48	Fully released	Less than 4.75
			Fully depressed	More than 0.36

Is the inspection result normal?

- YES >> INSPECTION END
- NO >> GO TO 2.

2. REPLACE ELECTRIC THROTTLE CONTROL ACTUATOR

1. Replace malfunctioning electric throttle control actuator.
2. Go to [EC-258, "Special Repair Requirement"](#).

>> INSPECTION END

Special Repair Requirement

INFOID:000000005151809

1. PERFORM THROTTLE VALVE CLOSED POSITION LEARNING

Refer to [EC-18, "THROTTLE VALVE CLOSED POSITION LEARNING : Special Repair Requirement"](#)

>> GO TO 2.

2. PERFORM IDLE AIR VOLUME LEARNING

P0222, P0223, P2132, P2133 TP SENSOR

< DTC/CIRCUIT DIAGNOSIS >

[VQ37VHR]

Refer to [EC-19. "IDLE AIR VOLUME LEARNING : Special Repair Requirement"](#)

>> END

A

EC

C

D

E

F

G

H

I

J

K

L

M

N

O

P

P0300, P0301, P0302, P0303, P0304, P0305, P0306 MISFIRE

< DTC/CIRCUIT DIAGNOSIS >

[VQ37VHR]

P0300, P0301, P0302, P0303, P0304, P0305, P0306 MISFIRE

DTC Logic

INFOID:000000005151810

DTC DETECTION LOGIC

When a misfire occurs, engine speed will fluctuate. If the engine speed fluctuates enough to cause the crankshaft position (CKP) sensor (POS) signal to vary, ECM can determine that a misfire is occurring.

Sensor	Input signal to ECM	ECM function
Crankshaft position sensor (POS)	Engine speed	On board diagnosis of misfire

The misfire detection logic consists of the following two conditions.

1. One Trip Detection Logic (Three Way Catalyst Damage)

On the 1st trip, when a misfire condition occurs that can damage the three way catalyst (TWC) due to overheating, the MIL will blink.

When a misfire condition occurs, the ECM monitors the CKP sensor signal every 200 engine revolutions for a change.

When the misfire condition decreases to a level that will not damage the TWC, the MIL will turn off.

If another misfire condition occurs that can damage the TWC on a second trip, the MIL will blink.

When the misfire condition decreases to a level that will not damage the TWC, the MIL will remain illuminating.

If another misfire condition occurs that can damage the TWC, the MIL will begin to blink again.

2. Two Trip Detection Logic (Exhaust quality deterioration)

For misfire conditions that will not damage the TWC (but will affect vehicle emissions), the MIL will only illuminate when the misfire is detected on a second trip. During this condition, the ECM monitors the CKP sensor signal every 1,000 engine revolutions.

A misfire malfunction can be detected in any one cylinder or in multiple cylinders.

DTC No.	Trouble diagnosis name	DTC detecting condition	Possible cause
P0300	Multiple cylinder misfires detected	Multiple cylinders misfire.	<ul style="list-style-type: none">• Improper spark plug• Insufficient compression• Incorrect fuel pressure• The fuel injector circuit is open or shorted• Fuel injector• Intake air leak• The ignition signal circuit is open or shorted• Lack of fuel• Signal plate• A/F sensor 1• Incorrect PCV hose connection
P0301	No.1 cylinder misfire detected	No. 1 cylinder misfires.	
P0302	No. 2 cylinder misfire detected	No. 2 cylinder misfires.	
P0303	No. 3 cylinder misfire detected	No. 3 cylinder misfires.	
P0304	No. 4 cylinder misfire detected	No. 4 cylinder misfires.	
P0305	No. 5 cylinder misfire detected	No. 5 cylinder misfires.	
P0306	No. 6 cylinder misfire detected	No. 6 cylinder misfires.	

DTC CONFIRMATION PROCEDURE

1. PRECONDITIONING

If DTC Confirmation Procedure has been previously conducted, always perform the following procedure before conducting the next test.

1. Turn ignition switch OFF and wait at least 10 seconds.
2. Turn ignition switch ON.
3. Turn ignition switch OFF and wait at least 10 seconds.

>> GO TO 2.

2. PERFORM DTC CONFIRMATION PROCEDURE-I

1. Start engine and warm it up to normal operating temperature.
2. Turn ignition switch OFF and wait at least 10 seconds.
3. Turn ignition switch ON.
4. Turn ignition switch OFF and wait at least 10 seconds.
5. Restart engine and let it idle for about 15 minutes.
6. Check 1st trip DTC.

P0300, P0301, P0302, P0303, P0304, P0305, P0306 MISFIRE

< DTC/CIRCUIT DIAGNOSIS >

[VQ37VHR]

Is 1st trip DTC detected?

YES >> Go to [EC-261, "Diagnosis Procedure"](#).

NO >> GO TO 3.

3.PERFORM DTC CONFIRMATION PROCEDURE-II

1. Turn ignition switch OFF and wait at least 10 seconds.
2. Turn ignition switch ON.
3. Turn ignition switch OFF and wait at least 10 seconds.
4. Start engine and drive the vehicle under similar conditions to (1st trip) Freeze Frame Data for a certain time. Refer to the table below.

Hold the accelerator pedal as steady as possible.

Similar conditions to (1st trip) Freeze Frame Data mean that the following conditions should be satisfied at the same time.

CAUTION:

Always drive vehicle in safe manner according to traffic conditions and obey all traffic laws when driving.

Engine speed	Engine speed in the freeze frame data \pm 400 rpm
Vehicle speed	Vehicle speed in the freeze frame data \pm 10 km/h (6 MPH)
Base fuel schedule	Base fuel schedule in the freeze frame data \times (1 \pm 0.1)
Engine coolant temperature (T) condition	When the freeze frame data shows lower than 70 °C (158 °F), T should be lower than 70 °C (158 °F).
	When the freeze frame data shows higher than or equal to 70 °C (158 °F), T should be higher than or equal to 70 °C (158 °F).

Driving time varies according to the engine speed in the freeze frame data.

Engine speed	Time
Around 1,000 rpm	Approximately 10 minutes
Around 2,000 rpm	Approximately 5 minutes
More than 3,000 rpm	Approximately 3.5 minutes

5. Check 1st trip DTC.

Is 1st trip DTC detected?

YES >> Go to [EC-261, "Diagnosis Procedure"](#).

NO >> INSPECTION END

Diagnosis Procedure

INFOID:000000005151811

1.CHECK FOR INTAKE AIR LEAK AND PCV HOSE

1. Start engine and run it at idle speed.
2. Listen for the sound of the intake air leak.
3. Check PCV hose connection.

Is intake air leak detected?

YES >> Discover air leak location and repair.

NO >> GO TO 2.

2.CHECK FOR EXHAUST SYSTEM CLOGGING

Stop engine and visually check exhaust tube, three way catalyst and muffler for dents.

Is the inspection result normal?

YES-1 >> With CONSULT-III: GO TO 3.

YES-2 >> Without CONSULT-III: GO TO 4.

NO >> Repair or replace it.

3.PERFORM POWER BALANCE TEST

 **With CONSULT-III**

1. Start engine.

P0300, P0301, P0302, P0303, P0304, P0305, P0306 MISFIRE

[VQ37VHR]

< DTC/CIRCUIT DIAGNOSIS >

2. Perform "POWER BALANCE" in "ACTIVE TEST" mode with CONSULT-III.
3. Make sure that each circuit produces a momentary engine speed drop.

Is the inspection result normal?

- YES >> GO TO 9.
NO >> GO TO 4.

4.CHECK FUNCTION OF FUEL INJECTOR-I

1. Start engine and let it idle.
2. Listen to each fuel injector operation sound.

Clicking sound should be heard.

Is the inspection result normal?

- YES >> GO TO 5.
NO >> Perform trouble diagnosis for FUEL INJECTOR, refer to [EC-492. "Diagnosis Procedure"](#).

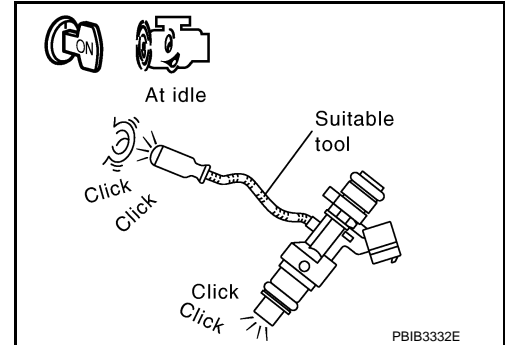

5.CHECK FUNCTION OF IGNITION COIL-I

CAUTION:

Perform the following procedure in a place where with no combustible objects and good ventilation.

1. Turn ignition switch OFF.
2. Remove fuel pump fuse (1) in IPDM E/R (2) to release fuel pressure.

NOTE:

Do not use CONSULT-III to release fuel pressure, or fuel pressure applies again during the following procedure.

3. Start engine.
4. After engine stalls, crank it two or three times to release all fuel pressure.
5. Turn ignition switch OFF.
6. Remove all ignition coil harness connectors to avoid the electrical discharge from the ignition coils.
7. Remove ignition coil and spark plug of the cylinder to be checked.
8. Crank engine for 5 seconds or more to remove combustion gas in the cylinder.
9. Connect spark plug and harness connector to ignition coil.
10. Fix ignition coil using a rope etc. with gap of 13 - 17 mm (0.52 - 0.66 in) between the edge of the spark plug and grounded metal portion as shown in the figure.
11. Crank engine for about 3 seconds, and check whether spark is generated between the spark plug and the grounded metal portion.

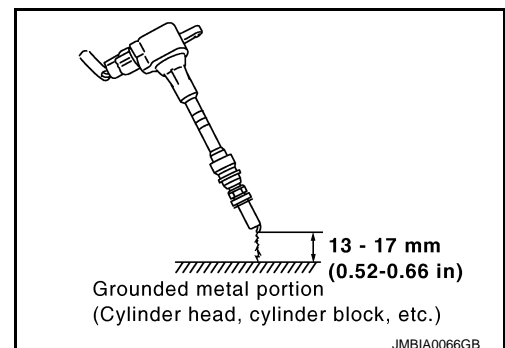
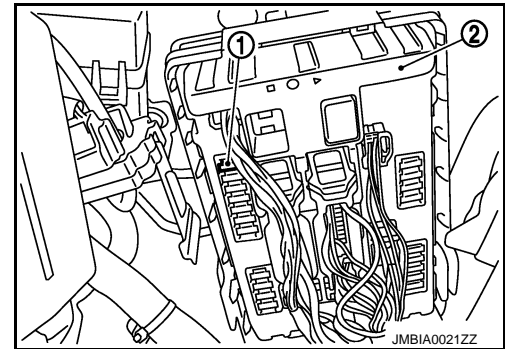

Spark should be generated.

CAUTION:

- During the operation, always stay 0.5 m (1.6 ft) or more away from the spark plug and ignition coil. Be careful not to get an electrical shock while checking, because the electrical discharge voltage becomes 20 kV or more.
- It might damage the ignition coil if the gap of more than 17 mm (0.66 in) is made.

NOTE:

When the gap is less than 13 mm (0.52 in), a spark might be generated even if the coil is malfunctioning.

Is the inspection result normal?

- YES >> GO TO 9.
NO >> GO TO 6.

6. CHECK FUNCTION OF IGNITION COIL-II

1. Turn ignition switch OFF.
2. Disconnect spark plug and connect a non-malfunctioning spark plug.
3. Crank engine for about 3 seconds, and recheck whether spark is generated between the spark plug and the grounded metal portion.

Spark should be generated.

Is the inspection result normal?

YES >> GO TO 7.

NO >> Check ignition coil, power transistor and their circuits. Refer to [EC-503. "Diagnosis Procedure"](#).

7. CHECK SPARK PLUG

Check the initial spark plug for fouling, etc.

Is the inspection result normal?

YES >> Replace spark plug(s) with standard type one(s). For spark plug type, refer to [EM-17. "Inspection"](#).

NO >> Repair or clean spark plug. Then GO TO 8.

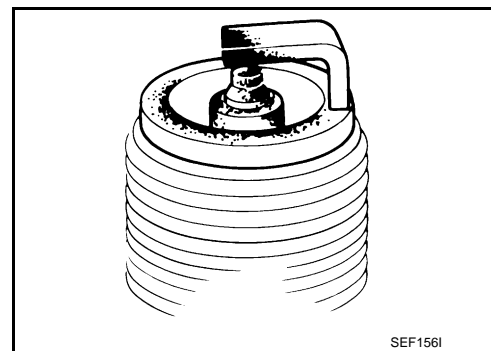

8. CHECK FUNCTION OF IGNITION COIL-III

1. Reconnect the initial spark plugs.
2. Crank engine for about 3 seconds, and recheck whether spark is generated between the spark plug and the grounded portion.

Spark should be generated.

Is the inspection result normal?

YES >> INSPECTION END

NO >> Replace spark plug(s) with standard type one(s). For spark plug type, refer to [EM-16. "Removal and Installation"](#).

9. CHECK COMPRESSION PRESSURE

Check compression pressure. Refer to [EM-23. "Inspection"](#).

Is the inspection result normal?

YES >> GO TO 10.

NO >> Check pistons, piston rings, valves, valve seats and cylinder head gaskets.

10. CHECK FUEL PRESSURE

1. Install all removed parts.
2. Release fuel pressure to zero. Refer to [EC-607. "Inspection"](#).
3. Install fuel pressure gauge and check fuel pressure. Refer to [EC-607. "Inspection"](#).

At idle: Approximately 350 kPa (3.57 kg/cm², 51 psi)

Is the inspection result normal?

YES >> GO TO 12.

NO >> GO TO 11.

11. DETECT MALFUNCTIONING PART

Check fuel hoses and fuel tubes for clogging.

Is the inspection result normal?

YES >> Replace "fuel filter and fuel pump assembly".

NO >> Repair or replace.

12. CHECK IDLE SPEED AND IGNITION TIMING

For procedure, refer to [EC-13, "BASIC INSPECTION : Special Repair Requirement"](#).
 For specification, refer to [EC-612, "Idle Speed"](#) and [EC-612, "Ignition Timing"](#).

Is the inspection result normal?

YES >> GO TO 13.

NO >> Follow the [EC-13, "BASIC INSPECTION : Special Repair Requirement"](#).

13. CHECK A/F SENSOR 1 INPUT SIGNAL CIRCUIT

1. Turn ignition switch OFF.
2. Disconnect corresponding A/F sensor 1 harness connector.
3. Disconnect ECM harness connector.
4. Check the continuity between A/F sensor 1 harness connector and ECM harness connector.

A/F sensor 1			ECM		Continuity
Bank	Connector	Terminal	Connector	Terminal	
1	F3	1	F102	57	Existed
		2		61	
2	F20	1		65	
		2		66	

5. Check the continuity between A/F sensor 1 harness connector and ground, or ECM harness connector and ground.

A/F sensor 1			Ground	Continuity
Bank	Connector	Terminal		
1	F3	1	Ground	Not existed
		2		
2	F20	1		
		2		

ECM			Ground	Continuity
Bank	Connector	Terminal		
1	F102	57	Ground	Not existed
		61		
2		65		
		66		

6. Also check harness for short to power.

Is the inspection result normal?

YES >> GO TO 14.

NO >> Repair open circuit, short to ground or short to power in harness or connectors.

14. CHECK A/F SENSOR 1 HEATER

Refer to [EC-158, "Component Inspection"](#).

Is the inspection result normal?

YES >> GO TO 15.

NO >> Replace (malfunctioning) A/F sensor 1.

15. CHECK MASS AIR FLOW SENSOR

 **With CONSULT-III**

Check mass air flow sensor signal in "DATA MONITOR" mode with CONSULT-III.
 For specification, refer to [EC-612, "Mass Air Flow Sensor"](#).

 **With GST**

P0300, P0301, P0302, P0303, P0304, P0305, P0306 MISFIRE

< DTC/CIRCUIT DIAGNOSIS >

[VQ37VHR]

Check mass air flow sensor signal in Service \$01 with GST.

For specification, refer to [EC-612, "Mass Air Flow Sensor"](#).

Is the measurement value within the specification?

YES >> GO TO 16.

NO >> Check connectors for rusted terminals or loose connections in the mass air flow sensor circuit or ground. Refer to [EC-173, "Diagnosis Procedure"](#).

A

EC

16.CHECK SYMPTOM TABLE

Check items on the rough idle symptom in [EC-595, "Symptom Table"](#).

Is the inspection result normal?

YES >> GO TO 17.

NO >> Repair or replace.

C

D

17.ERASE THE 1ST TRIP DTC

Some tests may cause a 1st trip DTC to be set.

Erase the 1st trip DTC from the ECM memory after performing the tests. Refer to [EC-107, "Diagnosis Description"](#).

E

F

>> GO TO 18.

18.CHECK INTERMITTENT INCIDENT

Refer to [GI-36, "Intermittent Incident"](#).

G

>> INSPECTION END

H

I

J

K

L

M

N

O

P

P0327, P0328, P0332, P0333 KS

Description

INFOID:000000005151812

The knock sensor is attached to the cylinder block. It senses engine knocking using a piezoelectric element. A knocking vibration from the cylinder block is sensed as vibrational pressure. This pressure is converted into a voltage signal and sent to the ECM.

DTC Logic

INFOID:000000005151813

DTC DETECTION LOGIC

DTC No.	Trouble diagnosis name	DTC detected condition	Possible cause
P0327	Knock sensor (bank 1) circuit low input	An excessively low voltage from the sensor is sent to ECM.	<ul style="list-style-type: none"> • Harness or connectors (The sensor circuit is open or shorted.) • Knock sensor
P0328	Knock sensor (bank 1) circuit high input	An excessively high voltage from the sensor is sent to ECM.	
P0332	Knock sensor (bank 2) circuit low input	An excessively low voltage from the sensor is sent to ECM.	
P0333	Knock sensor (bank 2) circuit high input	An excessively high voltage from the sensor is sent to ECM.	

DTC CONFIRMATION PROCEDURE

1. PRECONDITIONING

If DTC Confirmation Procedure has been previously conducted, always perform the following procedure before conducting the next test.

1. Turn ignition switch OFF and wait at least 10 seconds.
2. Turn ignition switch ON.
3. Turn ignition switch OFF and wait at least 10 seconds.

TESTING CONDITION:

Before performing the following procedure, confirm that battery voltage is more than 10 V at idle.

>> GO TO 2.

2. PERFORM DTC CONFIRMATION PROCEDURE

1. Start engine and run it for at least 5 seconds at idle speed.
2. Check 1st trip DTC.

Is 1st trip DTC detected?

- YES >> Go to [EC-266, "Diagnosis Procedure"](#).
 NO >> INSPECTION END

Diagnosis Procedure

INFOID:000000005151814

1. CHECK GROUND CONNECTION

1. Turn ignition switch OFF.
2. Check ground connection M95. Refer to Ground Inspection in [GI-39, "Circuit Inspection"](#).

Is the inspection result normal?

- YES >> GO TO 2.
 NO >> Repair or replace ground connection.

2. CHECK KNOCK SENSOR GROUND CIRCUIT FOR OPEN AND SHORT

1. Disconnect knock sensor harness connector and ECM harness connector.
2. Check the continuity between knock sensor harness connector and ECM harness connector.

DTC	Knock sensor			ECM		Continuity
	Bank	Connector	Terminal	Connector	Terminal	
P0327, P0328	1	F203	2	F102	72	Existed
P0332, P0333	2	F202	2			

3. Also check harness for short to power.

Is the inspection result normal?

- YES >> GO TO 4.
- NO >> GO TO 3.

3.DETECT MALFUNCTIONING PART

Check the following.

- Harness connectors F9, F201
- Harness for open or short between knock sensor and ECM

>> Repair open circuit or short to power in harness or connectors.

4.CHECK KNOCK SENSOR INPUT SIGNAL CIRCUIT FOR OPEN AND SHORT

1. Check the continuity between knock sensor harness connector and ECM harness connector.

DTC	Knock sensor			ECM		Continuity
	Bank	Connector	Terminal	Connector	Terminal	
P0327, P0328	1	F203	1	F102	73	Existed
P0332, P0333	2	F202	1		69	

2. Also check harness for short to ground and short to power.

Is the inspection result normal?

- YES >> GO TO 6.
- NO >> GO TO 5.

5.DETECT MALFUNCTIONING PART

Check the following.

- Harness connectors F9, F201
- Harness for open or short between ECM and knock sensor

>> Repair open circuit, short to ground or short to power in harness or connectors.

6.CHECK KNOCK SENSOR

Refer to [EC-267, "Component Inspection"](#).

Is the inspection result normal?

- YES >> GO TO 7.
- NO >> Replace malfunctioning knock sensor.

7.CHECK INTERMITTENT INCIDENT

Refer to [GI-36, "Intermittent Incident"](#).

>> INSPECTION END

Component Inspection

INFOID:000000005151815

1.CHECK KNOCK SENSOR

1. Turn ignition switch OFF.
2. Disconnect knock sensor harness connector.
3. Check resistance between knock sensor terminals as per the following.

NOTE:

P0327, P0328, P0332, P0333 KS

[VQ37VHR]

< DTC/CIRCUIT DIAGNOSIS >

It is necessary to use an ohmmeter which can measure more than 10 MΩ.

Terminals	Resistance (kΩ)
1 and 2	Approx. 532 - 588 [at 20°C (68°F)]

CAUTION:

Do not use any knock sensors that have been dropped or physically damaged. Use only new ones.

Is the inspection result normal?

YES >> INSPECTION END

NO >> Replace malfunctioning knock sensor.

P0335 CKP SENSOR (POS)

< DTC/CIRCUIT DIAGNOSIS >

[VQ37VHR]

P0335 CKP SENSOR (POS)

Description

INFOID:000000005151816

The crankshaft position sensor (POS) is located on the cylinder block facing the gear teeth (cogs) of the signal plate. It detects the fluctuation of the engine revolution.

The sensor consists of a permanent magnet and Hall IC.

When the engine is running, the high and low parts of the teeth cause the gap with the sensor to change.

The changing gap causes the magnetic field near the sensor to change.

Due to the changing magnetic field, the voltage from the sensor changes.

The ECM receives the voltage signal and detects the fluctuation of the engine revolution.

ECM receives the signals as shown in the figure.

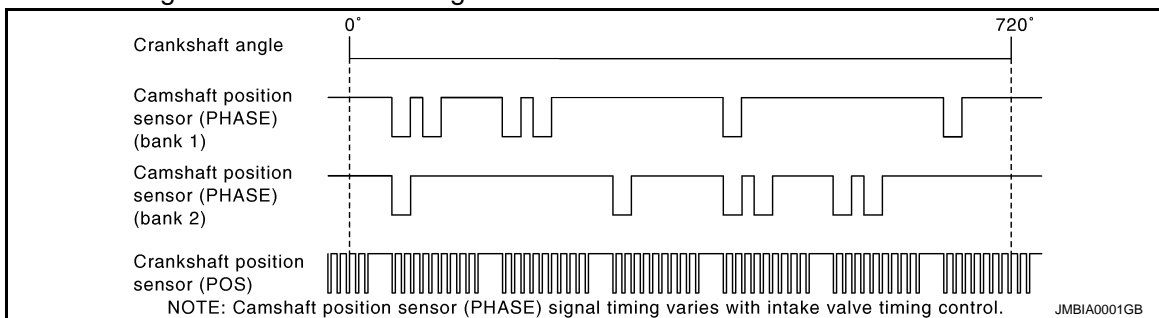
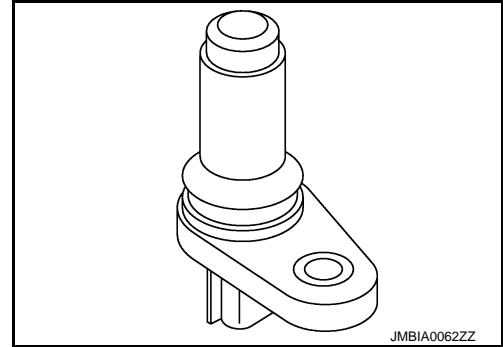

DTC Logic

INFOID:000000005151817

DTC DETECTION LOGIC

DTC No.	Trouble diagnosis name	DTC detecting condition	Possible cause
P0335	Crankshaft position sensor (POS) circuit	<ul style="list-style-type: none"> The crankshaft position sensor (POS) signal is not detected by the ECM during the first few seconds of engine cranking. The proper pulse signal from the crankshaft position sensor (POS) is not sent to ECM while the engine is running. The crankshaft position sensor (POS) signal is not in the normal pattern during engine running. 	<ul style="list-style-type: none"> Harness or connectors [CKP sensor (POS) circuit is open or shorted.] (APP sensor 2 circuit is shorted.) (EVAP control system pressure sensor circuit is shorted.) (Refrigerant pressure sensor circuit is shorted.) (Brake booster pressure sensor circuit is shorted) Crankshaft position sensor (POS) Accelerator pedal position sensor EVAP control system pressure sensor Refrigerant pressure sensor Brake booster pressure sensor. Signal plate

DTC CONFIRMATION PROCEDURE

1. PRECONDITIONING

If DTC Confirmation Procedure has been previously conducted, always perform the following procedure before conducting the next test.

- Turn ignition switch OFF and wait at least 10 seconds.
- Turn ignition switch ON.
- Turn ignition switch OFF and wait at least 10 seconds.

TESTING CONDITION:

Before performing the following procedure, confirm that battery voltage is more than 10.5 V with ignition switch ON.

P0335 CKP SENSOR (POS)

< DTC/CIRCUIT DIAGNOSIS >

[VQ37VHR]

>> GO TO 2.

2. PERFORM DTC CONFIRMATION PROCEDURE

1. Start engine and let it idle for at least 5 seconds.
If engine does not start, crank engine for at least 2 seconds.
2. Check 1st trip DTC.

Is 1st trip DTC detected?

- YES >> Go to [EC-270, "Diagnosis Procedure"](#).
NO >> INSPECTION END

Diagnosis Procedure

INFOID:000000005151818

1. CHECK GROUND CONNECTION

1. Turn ignition switch OFF.
2. Check ground connection M95. Refer to Ground Inspection in [GI-39, "Circuit Inspection"](#).

Is the inspection result normal?

- YES >> GO TO 2.
NO >> Repair or replace ground connection.

2. CHECK CRANKSHAFT POSITION (CKP) SENSOR (POS) POWER SUPPLY CIRCUIT-I

1. Disconnect crankshaft position (CKP) sensor (POS) harness connector.
2. Turn ignition switch ON.
3. Check the voltage between CKP sensor (POS) harness connector and ground.

CKP sensor (POS)		Ground	Voltage (V)
Connector	Terminal		
F2	1	Ground	Approx. 5

Is the inspection result normal?

- YES >> GO TO 8.
NO >> GO TO 3.

3. CHECK CRANKSHAFT POSITION (CKP) SENSOR (POS) POWER SUPPLY CIRCUIT-II

1. Turn ignition switch ON.
2. Disconnect ECM harness connector.
3. Check the continuity between CKP sensor (POS) harness connector and ECM harness connector.

CKP sensor (POS)		ECM		Continuity
Connector	Terminal	Connector	Terminal	
F2	1	F101	46	Existed

Is the inspection result normal?

- YES >> GO TO 4.
NO >> Repair open circuit.

4. CHECK SENSOR POWER SUPPLY CIRCUIT

Check harness for short to power and short to ground, between the following terminals.

ECM		Sensor		
Connector	Terminal	Name	Connector	Terminal
F101	45	Brake booster pressure sensor	E48	1
	46	CKP sensor (POS)	F2	

P0335 CKP SENSOR (POS)

[VQ37VHR]

< DTC/CIRCUIT DIAGNOSIS >

ECM		Sensor		
Connector	Terminal	Name	Connector	Terminal
M107	103	APP sensor	E112	6
	107	EVAP control system pressure sensor	B30	3
		Refrigerant pressure sensor	E77	3

Is the inspection result normal?

YES >> GO TO 5.

NO >> Repair short to ground or short to power in harness or connectors.

5. CHECK COMPONENTS

Check the following.

- Brake booster pressure sensor (Refer to [EC-357, "Component Inspection"](#).)
- EVAP control system pressure sensor (Refer to [EC-311, "Component Inspection"](#).)
- Refrigerant pressure sensor (Refer to [EC-516, "Diagnosis Procedure"](#).)

Is the inspection result normal?

YES >> GO TO 6.

NO >> Replace malfunctioning component.

6. CHECK APP SENSOR

Refer to [EC-465, "Component Inspection"](#).

Is the inspection result normal?

YES >> GO TO 12.

NO >> GO TO 7.

7. REPLACE ACCELERATOR PEDAL ASSEMBLY

1. Replace accelerator pedal assembly.
2. Go to [EC-465, "Special Repair Requirement"](#).

>> INSPECTION END

8. CHECK CKP SENSOR (POS) GROUND CIRCUIT FOR OPEN AND SHORT

1. Turn ignition switch OFF.
2. Disconnect ECM harness connector.
3. Check the continuity between CKP sensor (POS) harness connector and ECM harness connector.

CKP sensor (POS)		ECM		Continuity
Connector	Terminal	Connector	Terminal	
F2	2	F101	47	Existed

4. Also check harness for short to ground and short to power.

Is the inspection result normal?

YES >> GO TO 9.

NO >> Repair open circuit, short to ground or short to power in harness or connectors.

9. CHECK CKP SENSOR (POS) INPUT SIGNAL CIRCUIT FOR OPEN AND SHORT

1. Check the continuity between CKP sensor (POS) harness connector and ECM harness connector.

CKP sensor (POS)		ECM		Continuity
Connector	Terminal	Connector	Terminal	
F2	3	F101	37	Existed

2. Also check harness for short to ground and short to power.

Is the inspection result normal?

YES >> GO TO 10.

NO >> Repair open circuit, short to ground or short to power in harness or connectors.

P0335 CKP SENSOR (POS)

[VQ37VHR]

< DTC/CIRCUIT DIAGNOSIS >

10. CHECK CRANKSHAFT POSITION SENSOR (POS)

Refer to [EC-272. "Component Inspection"](#).

Is the inspection result normal?

YES >> GO TO 11.

NO >> Replace crankshaft position sensor (POS).

11. CHECK GEAR TOOTH

Visually check for chipping signal plate gear tooth.

Is the inspection result normal?

YES >> GO TO 12.

NO >> Replace the signal plate.

12. CHECK INTERMITTENT INCIDENT

Refer to [GI-36. "Intermittent Incident"](#).

>> INSPECTION END

Component Inspection

INFOID:000000005151819

1. CHECK CRANKSHAFT POSITION SENSOR (POS)-I

1. Turn ignition switch OFF.
2. Loosen the fixing bolt of the sensor.
3. Disconnect crankshaft position sensor (POS) harness connector.
4. Remove the sensor.
5. Visually check the sensor for chipping.

Is the inspection result normal?

YES >> GO TO 2.

NO >> Replace crankshaft position sensor (POS).

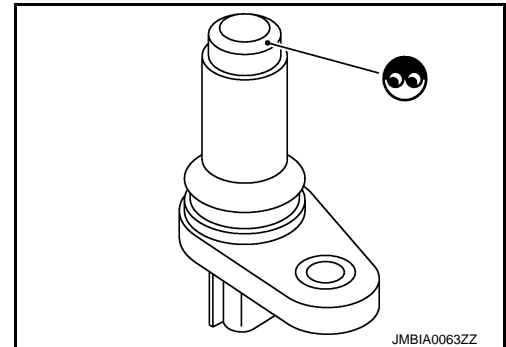

2. CHECK CRANKSHAFT POSITION SENSOR (POS)-II

Check resistance between crankshaft position sensor (POS) terminals as follows.

Terminals (Polarity)	Resistance (Ω)
1 (+) - 2 (-)	Except 0 or ∞ [at 25°C (77°F)]
1 (+) - 3 (-)	
2 (+) - 3 (-)	

Is the inspection result normal?

YES >> INSPECTION END

NO >> Replace crankshaft position sensor (POS).

P0340, P0345 CMP SENSOR (PHASE)

< DTC/CIRCUIT DIAGNOSIS >

[VQ37VHR]

P0340, P0345 CMP SENSOR (PHASE)

Description

INFOID:000000005151820

The camshaft position sensor (PHASE) senses the retraction of camshaft (INT) to identify a particular cylinder. The camshaft position sensor (PHASE) senses the piston position.

When the crankshaft position sensor (POS) system becomes inoperative, the camshaft position sensor (PHASE) provides various controls of engine parts instead, utilizing timing of cylinder identification signals.

The sensor consists of a permanent magnet and Hall IC.

When engine is running, the high and low parts of the teeth cause the gap with the sensor to change.

The changing gap causes the magnetic field near the sensor to change.

Due to the changing magnetic field, the voltage from the sensor changes.

ECM receives the signals as shown in the figure.

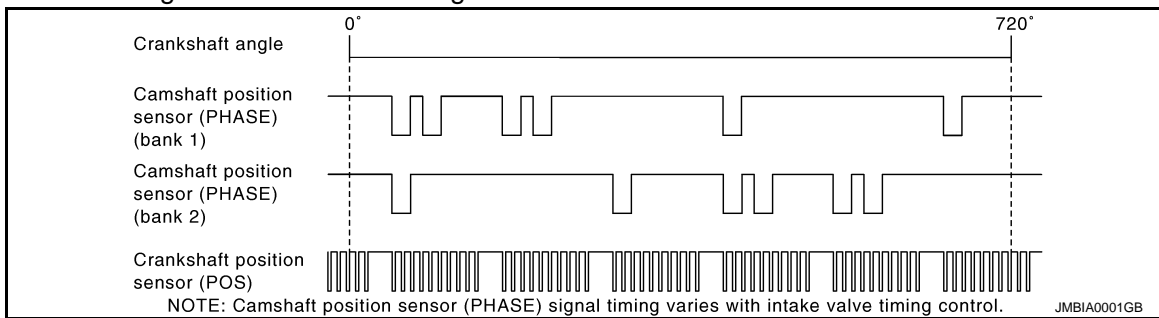
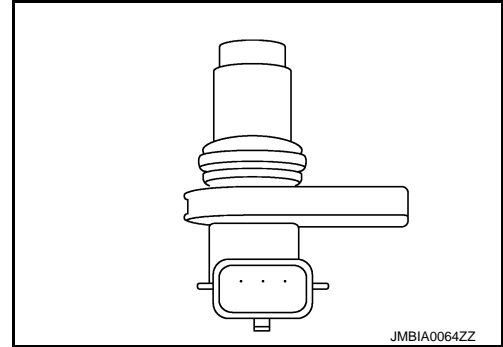

DTC Logic

INFOID:000000005151821

DTC DETECTION LOGIC

NOTE:

If DTC P0340 or P0345 is displayed with DTC P0643, first perform the trouble diagnosis for DTC P0643. Refer to [EC-364, "DTC Logic"](#).

DTC No.	Trouble diagnosis name	DTC detecting condition	Possible cause
P0340	Camshaft position sensor (PHASE) (bank 1) circuit	<ul style="list-style-type: none"> The cylinder No. signal is not sent to ECM for the first few seconds during engine cranking. The cylinder No. signal is not sent to ECM during engine running. 	<ul style="list-style-type: none"> Harness or connectors [CMP sensor (PHASE) (bank 1) circuit is open or shorted.] Camshaft position sensor (PHASE) (bank 1) Camshaft (INT) Starter motor Starting system circuit Dead (Weak) battery
P0345	Camshaft position sensor (PHASE) (bank 2) circuit	<ul style="list-style-type: none"> The cylinder No. signal is not in the normal pattern during engine running. 	<ul style="list-style-type: none"> Harness or connectors [CMP sensor (PHASE) (bank 2) circuit is open or shorted.] Camshaft position sensor (PHASE) (bank 2) Camshaft (INT) Starter motor Starting system circuit Dead (Weak) battery

DTC CONFIRMATION PROCEDURE

1. PRECONDITIONING

If DTC Confirmation Procedure has been previously conducted, always perform the following procedure before conducting the next test.

P0340, P0345 CMP SENSOR (PHASE)

[VQ37VHR]

< DTC/CIRCUIT DIAGNOSIS >

1. Turn ignition switch OFF and wait at least 10 seconds.
2. Turn ignition switch ON.
3. Turn ignition switch OFF and wait at least 10 seconds.

TESTING CONDITION:

Before performing the following procedure, confirm that battery voltage is more than 10.5 V with ignition switch ON.

>> GO TO 2.

2.PERFORM DTC CONFIRMATION PROCEDURE-I

1. Start engine and let it idle for at least 5 seconds.
If engine does not start, crank engine for at least 2 seconds.
2. Check 1st trip DTC.

Is 1st trip DTC detected?

- YES >> Go to [EC-274, "Diagnosis Procedure"](#).
NO >> GO TO 3.

3.PERFORM DTC CONFIRMATION PROCEDURE-II

1. Maintaining engine speed at more than 800 rpm for at least 5 seconds.
2. Check 1st trip DTC.

Is 1st trip DTC detected?

- YES >> Go to [EC-274, "Diagnosis Procedure"](#).
NO >> INSPECTION END

Diagnosis Procedure

INFOID:000000005151822

1.CHECK STARTING SYSTEM

Turn ignition switch to START position.

Does the engine turn over? Does the starter motor operate?

- YES >> GO TO 2.
NO >> Check starting system. (Refer to [EC-9, "Work Flow"](#).)

2.CHECK GROUND CONNECTION

1. Turn ignition switch OFF.
2. Check ground connection M95. Refer to Ground Inspection in [GI-39, "Circuit Inspection"](#).

Is the inspection result normal?

- YES >> GO TO 3.
NO >> Repair or replace ground connection.

3.CHECK CAMSHAFT POSITION (CMP) SENSOR (PHASE) POWER SUPPLY CIRCUIT

1. Disconnect camshaft position (CMP) sensor (PHASE) harness connector.
2. Turn ignition switch ON.
3. Check the voltage between CMP sensor (PHASE) harness connector and ground.

DTC	CMP sensor (PHASE)			Ground	Voltage (V)
	Bank	Connector	Terminal		
P0340	1	F5	1	Ground	Approx. 5
P0345	2	F18	1		

Is the inspection result normal?

- YES >> GO TO 4.
NO >> Repair open circuit, short to ground or short to power in harness or connectors.

4.CHECK CMP SENSOR (PHASE) GROUND CIRCUIT FOR OPEN AND SHORT

1. Turn ignition switch OFF.
2. Disconnect ECM harness connector.
3. Check the continuity between CMP sensor (PHASE) harness connector and ECM harness connector.

P0340, P0345 CMP SENSOR (PHASE)

< DTC/CIRCUIT DIAGNOSIS >

[VQ37VHR]

DTC	CMP sensor (PHASE)			ECM		Continuity
	Bank	Connector	Terminal	Connector	Terminal	
P0340	1	F5	2	F102	96	Existed
P0345	2	F18	2		92	

4. Also check harness for short to ground and short to power.

Is the inspection result normal?

YES >> GO TO 5.

NO >> Repair open circuit, short to ground or short to power in harness or connectors.

5.CHECK CMP SENSOR (PHASE) INPUT SIGNAL CIRCUIT FOR OPEN AND SHORT

1. Check the continuity between CMP sensor (PHASE) harness connector and ECM harness connector.

DTC	CMP sensor (PHASE)			ECM		Continuity
	Bank	Connector	Terminal	Connector	Terminal	
P0340	1	F5	3	F102	59	Existed
P0345	2	F18	3		63	

2. Also check harness for short to ground and short to power.

Is the inspection result normal?

YES >> GO TO 6.

NO >> Repair open circuit, short to ground or short to power in harness or connectors.

6.CHECK CAMSHAFT POSITION SENSOR (PHASE)

Refer to [EC-275, "Component Inspection"](#).

Is the inspection result normal?

YES >> GO TO 7.

NO >> Replace malfunctioning camshaft position sensor (PHASE).

7.CHECK CAMSHAFT (INTAKE)

Check the following.

- Accumulation of debris to the signal plate of camshaft front end
- Chipping signal plate of camshaft front end

Is the inspection result normal?

YES >> GO TO 8.

NO >> Remove debris and clean the signal plate of camshaft front end or replace camshaft.

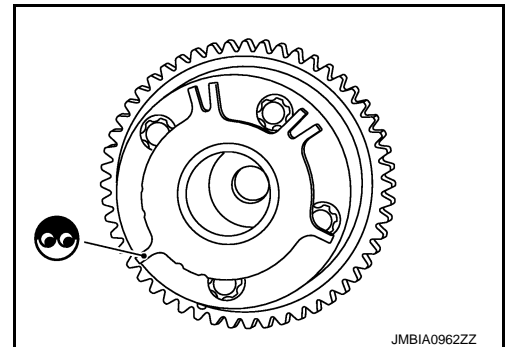

8.CHECK INTERMITTENT INCIDENT

Refer to [GI-36, "Intermittent Incident"](#).

>> INSPECTION END

Component Inspection

INFOID:000000005151823

1.CHECK CAMSHAFT POSITION SENSOR (PHASE)-I

1. Turn ignition switch OFF.
2. Loosen the fixing bolt of the sensor.
3. Disconnect camshaft position sensor (PHASE) harness connector.
4. Remove the sensor.

P0340, P0345 CMP SENSOR (PHASE)

[VQ37VHR]

< DTC/CIRCUIT DIAGNOSIS >

5. Visually check the sensor for chipping.

Is the inspection result normal?

YES >> GO TO 2.

NO >> Replace malfunctioning camshaft position sensor (PHASE).

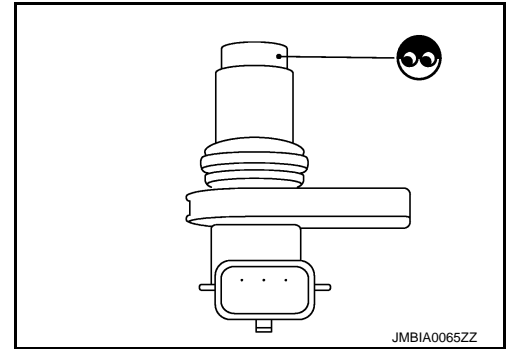

2. CHECK CAMSHAFT POSITION SENSOR (PHASE)-II

Check resistance camshaft position sensor (PHASE) terminals as follows.

Terminals (Polarity)	Resistance (Ω)
1 (+) - 2 (-)	Except 0 or ∞ [at 25°C (77°F)]
1 (+) - 3 (-)	
2 (+) - 3 (-)	

Is the inspection result normal?

YES >> INSPECTION END

NO >> Replace malfunctioning camshaft position sensor (PHASE).

P0420, P0430 THREE WAY CATALYST FUNCTION

< DTC/CIRCUIT DIAGNOSIS >

[VQ37VHR]

P0420, P0430 THREE WAY CATALYST FUNCTION

DTC Logic

INFOID:000000005151824

DTC DETECTION LOGIC

The ECM monitors the switching frequency ratio of air fuel ratio (A/F) sensor 1 and heated oxygen sensor 2. A three way catalyst 1 with high oxygen storage capacity will indicate a low switching frequency of heated oxygen sensor 2. As oxygen storage capacity decreases, the heated oxygen sensor 2 switching frequency will increase.

When the frequency ratio of A/F sensor 1 and heated oxygen sensor 2 approaches a specified limit value, the three way catalyst 1 malfunction is diagnosed.

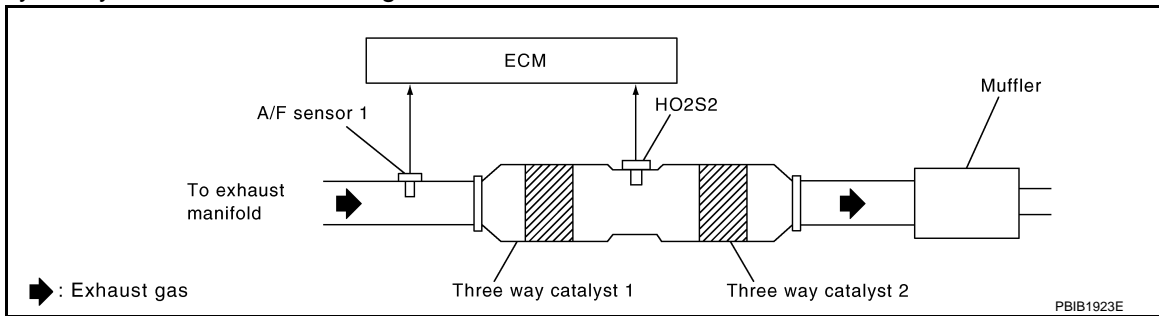

DTC No.	Trouble diagnosis name	DTC detecting condition	Possible cause
P0420	Catalyst system efficiency below threshold (bank 1)	<ul style="list-style-type: none"> • Three way catalyst (manifold) does not operate properly. • Three way catalyst (manifold) does not have enough oxygen storage capacity. 	<ul style="list-style-type: none"> • Three way catalyst (manifold) • Exhaust tube • Intake air leaks • Fuel injector • Fuel injector leaks • Spark plug • Improper ignition timing
P0430	Catalyst system efficiency below threshold (bank 2)		

DTC CONFIRMATION PROCEDURE

1. INSPECTION START

Do you have CONSULT-III?

Do you have CONSULT-III?

YES >> GO TO 2.

NO >> GO TO 7.

2. PRECONDITIONING

If DTC Confirmation Procedure has been previously conducted, always perform the following procedure before conducting the next test.

1. Turn ignition switch OFF and wait at least 10 seconds.
2. Turn ignition switch ON.
3. Turn ignition switch OFF and wait at least 10 seconds.

TESTING CONDITION:

Do not hold engine speed for more than the specified minutes below.

>> GO TO 3.

3. PERFORM DTC CONFIRMATION PROCEDURE-I

With CONSULT-III

1. Turn ignition switch ON and select "DATA MONITOR" mode with CONSULT-III.
2. Start engine and warm it up to the normal operating temperature.
3. Turn ignition switch OFF and wait at least 10 seconds.
4. Turn ignition switch ON.
5. Turn ignition switch OFF and wait at least 10 seconds.
6. Start engine and keep the engine speed between 3,500 and 4,000 rpm for at least 1 minute under no load.
7. Let engine idle for 1 minute.

P0420, P0430 THREE WAY CATALYST FUNCTION

[VQ37VHR]

< DTC/CIRCUIT DIAGNOSIS >

8. Make sure that "COOLAN TEMP/S" indicates more than 70°C (158°F).
If not, warm up engine and go to next step when "COOLAN TEMP/S" indication reaches 70°C (158°F).
9. Open engine hood.
10. Select "DTC & SRT CONFIRMATION" then "SRT WORK SUPPORT" mode with CONSULT-III.
11. Rev engine up to about 2,000 rpm and hold it for 3 consecutive minutes then release the accelerator pedal completely.
12. Check the indication of "CATALYST".

Which is displayed on CONSULT-III screen?

CMPLT >> GO TO 6.

INCMP >> GO TO 4.

4. PERFORM DTC CONFIRMATION PROCEDURE-II

1. Wait 5 seconds at idle.
2. Rev engine up to about 2,000 rpm and maintain it until "INCMP" of "CATALYST" changes to "CMPLT" (It will take approximately 5 minutes).

Does the indication change to "CMPLT"?

YES >> GO TO 6.

NO >> GO TO 5.

5. PERFORM DTC CONFIRMATION PROCEDURE AGAIN

1. Stop engine and cool it down to less than 70°C (158°F).
2. Perform DTC CONFIRMATION PROCEDURE again.

>> GO TO 3.

6. PERFORM DTC CONFIRMATION PROCEDURE-III

Check 1st trip DTC.

Is 1st trip DTC detected?

YES >> Go to [EC-279, "Diagnosis Procedure"](#).

NO >> INSPECTION END

7. PERFORM COMPONENT FUNCTION CHECK

Perform component function check. Refer to [EC-278, "Component Function Check"](#).

NOTE:

Use component function check to check the overall function of the three way catalyst (manifold). During this check, a 1st trip DTC might not be confirmed.

Is the inspection result normal?

YES >> INSPECTION END

NO >> Go to [EC-279, "Diagnosis Procedure"](#).

Component Function Check

INFOID:000000005151825

1. PERFORM COMPONENT FUNCTION CHECK

⊗ Without CONSULT-III

1. Start engine and warm it up to the normal operating temperature.
2. Turn ignition switch OFF and wait at least 10 seconds.
3. Start engine and keep the engine speed between 3,500 and 4,000 rpm for at least 1 minute under no load.
4. Let engine idle for 1 minute.
5. Open engine hood.
6. Check the voltage between ECM harness connector terminals under the following condition.

P0420, P0430 THREE WAY CATALYST FUNCTION

< DTC/CIRCUIT DIAGNOSIS >

[VQ37VHR]

DTC	ECM		Condition	Voltage	
	Connector	+			-
		Terminal			Terminal
P0420	F102	76 [HO2S2 (bank 1)]	84	Keeping engine speed at 2,500 rpm constant under no load	
P0430		80 [HO2S2 (bank 2)]			

A

EC

C

D

Is the inspection result normal?

- YES >> INSPECTION END
- NO >> Go to [EC-279, "Diagnosis Procedure"](#).

Diagnosis Procedure

INFOID:000000005151826

1. CHECK EXHAUST SYSTEM

Visually check exhaust tubes and muffler for dents.

Is the inspection result normal?

- YES >> GO TO 2.
- NO >> Repair or replace.

2. CHECK EXHAUST GAS LEAK

1. Start engine and run it at idle.
2. Listen for an exhaust gas leak before the three way catalyst 1.

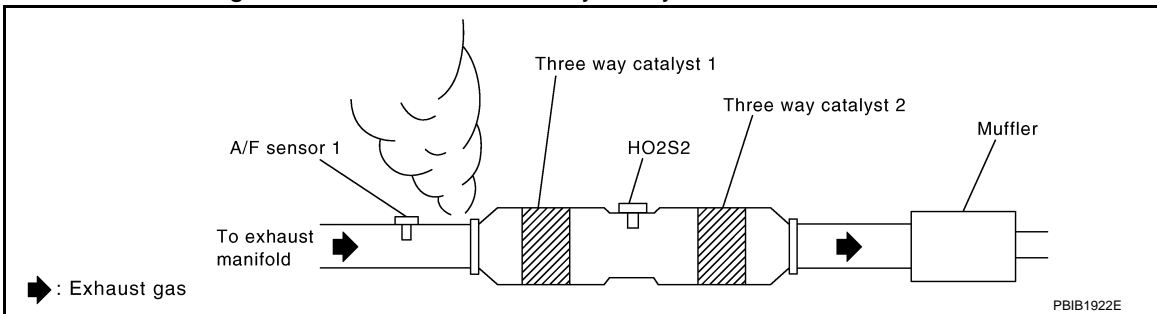

Is exhaust gas leak detected?

- YES >> Repair or replace.
- NO >> GO TO 3.

3. CHECK INTAKE AIR LEAK

Listen for an intake air leak after the mass air flow sensor.

Is intake air leak detected?

- YES >> Repair or replace.
- NO >> GO TO 4.

4. CHECK IDLE SPEED AND IGNITION TIMING

For procedure, refer to [EC-13, "BASIC INSPECTION : Special Repair Requirement"](#).
For specification, refer to [EC-612, "Idle Speed"](#) and [EC-612, "Ignition Timing"](#).

Is the inspection result normal?

- YES >> GO TO 5.
- NO >> Follow the [EC-13, "BASIC INSPECTION : Special Repair Requirement"](#).

5. CHECK FUEL INJECTORS

1. Stop engine and then turn ignition switch ON.
2. Check the voltage between ECM harness connector terminals as per the following.

E

F

G

H

I

J

K

L

M

N

O

P

P0420, P0430 THREE WAY CATALYST FUNCTION

< DTC/CIRCUIT DIAGNOSIS >

[VQ37VHR]

ECM				Voltage
+		-		
Connector	Terminal	Connector	Terminal	
F102	81	M107	128	Battery voltage
	82			
	85			
	86			
	89			
	90			

Is the inspection result normal?

YES >> GO TO 6.

NO >> Perform [EC-492, "Diagnosis Procedure"](#).

6. CHECK FUNCTION OF IGNITION COIL-I

CAUTION:

Perform the following procedure in a place where with no combustible objects and good ventilation.

1. Turn ignition switch OFF.
2. Remove fuel pump fuse (1) in IPDM E/R (2) to release fuel pressure.

NOTE:

Do not use CONSULT-III to release fuel pressure, or fuel pressure applies again during the following procedure.

3. Start engine.
4. After engine stalls, crank it two or three times to release all fuel pressure.
5. Turn ignition switch OFF.
6. Remove all ignition coil harness connectors to avoid the electrical discharge from the ignition coils.
7. Remove ignition coil and spark plug of the cylinder to be checked.
8. Crank engine for 5 seconds or more to remove combustion gas in the cylinder.
9. Connect spark plug and harness connector to ignition coil.
10. Fix ignition coil using a rope etc. with gap of 13 - 17 mm (0.52 - 0.66 in) between the edge of the spark plug and grounded metal portion as shown in the figure.
11. Crank engine for about 3 seconds, and check whether spark is generated between the spark plug and the grounded metal portion.

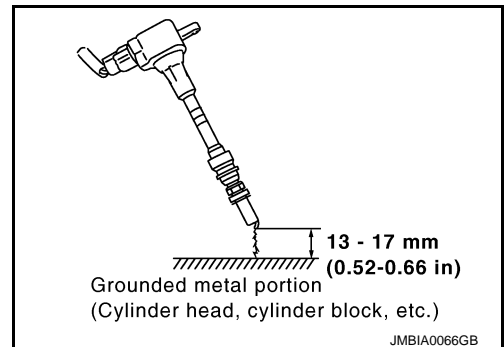
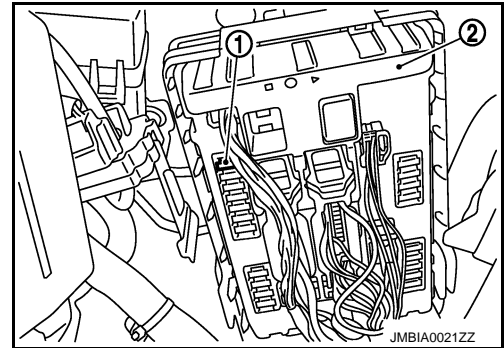

Spark should be generated.

CAUTION:

- During the operation, always stay 0.5 m (1.6 ft) or more away from the spark plug and ignition coil. Be careful not to get an electrical shock while checking, because the electrical discharge voltage becomes 20 kV or more.
- It might damage the ignition coil if the gap of more than 17 mm (0.66 in) is made.

NOTE:

When the gap is less than 13 mm (0.52 in), a spark might be generated even if the coil is malfunctioning.

Is the inspection result normal?

YES >> GO TO 10.

NO >> GO TO 7.

7. CHECK FUNCTION OF IGNITION COIL-II

1. Turn ignition switch OFF.

P0420, P0430 THREE WAY CATALYST FUNCTION

[VQ37VHR]

< DTC/CIRCUIT DIAGNOSIS >

2. Disconnect spark plug and connect a non-malfunctioning spark plug.
3. Crank engine for about 3 seconds, and recheck whether spark is generated between the spark plug and the grounded metal portion.

Spark should be generated.

Is the inspection result normal?

YES >> GO TO 8.

NO >> Check ignition coil, power transistor and their circuits. Refer to [EC-503, "Diagnosis Procedure"](#).

8.CHECK SPARK PLUG

Check the initial spark plug for fouling, etc.

Is the inspection result normal?

YES >> Replace spark plug(s) with standard type one(s). For spark plug type, refer to [EM-17, "Inspection"](#).

NO >> Repair or clean spark plug. Then GO TO 9.

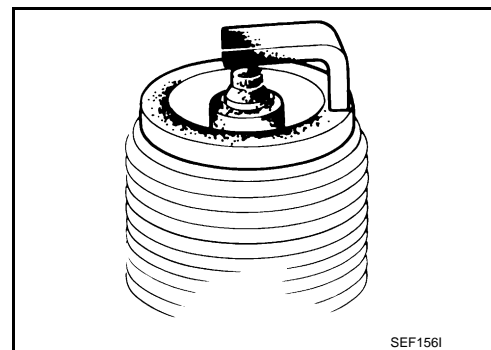

9.CHECK FUNCTION OF IGNITION COIL-III

1. Reconnect the initial spark plugs.
2. Crank engine for about three seconds, and recheck whether spark is generated between the spark plug and the grounded portion.

Spark should be generated.

Is the inspection result normal?

YES >> INSPECTION END

NO >> Replace spark plug(s) with standard type one(s). For spark plug type, refer to [EM-16, "Removal and Installation"](#).

10.CHECK FUEL INJECTOR

1. Turn ignition switch OFF.
2. Remove fuel injector assembly.
Refer to [EM-37, "Removal and Installation"](#).
Keep fuel hose and all fuel injectors connected to fuel tube.
3. Disconnect all ignition coil harness connectors.
4. Reconnect all fuel injector harness connectors disconnected.
5. Turn ignition switch ON.
6. Check that fuel does not drip from fuel injector.

Does fuel drip from fuel injector?

YES >> Replace the fuel injector(s) from which fuel is dripping.

NO >> GO TO 11.

11.CHECK INTERMITTENT INCIDENT

Refer to [GI-36, "Intermittent Incident"](#).

Is the inspection result normal?

YES >> Replace three way catalyst assembly.

NO >> Repair or replace harness or connector.

P0441 EVAP CONTROL SYSTEM

< DTC/CIRCUIT DIAGNOSIS >

[VQ37VHR]

P0441 EVAP CONTROL SYSTEM

DTC Logic

INFOID:000000005151827

DTC DETECTION LOGIC

NOTE:

If DTC P0441 is displayed with other DTC such as P2122, P2123, P2127, P2128 or P2138, first perform trouble diagnosis for other DTC.

In this evaporative emission (EVAP) control system, purge flow occurs during non-closed throttle conditions. Purge volume is related to air intake volume. Under normal purge conditions (non-closed throttle), the EVAP canister purge volume control solenoid valve is open to admit purge flow. Purge flow exposes the EVAP control system pressure sensor to intake manifold vacuum.

Under normal conditions (non-closed throttle), sensor output voltage indicates if pressure drop and purge flow are adequate. If not, a malfunction is determined.

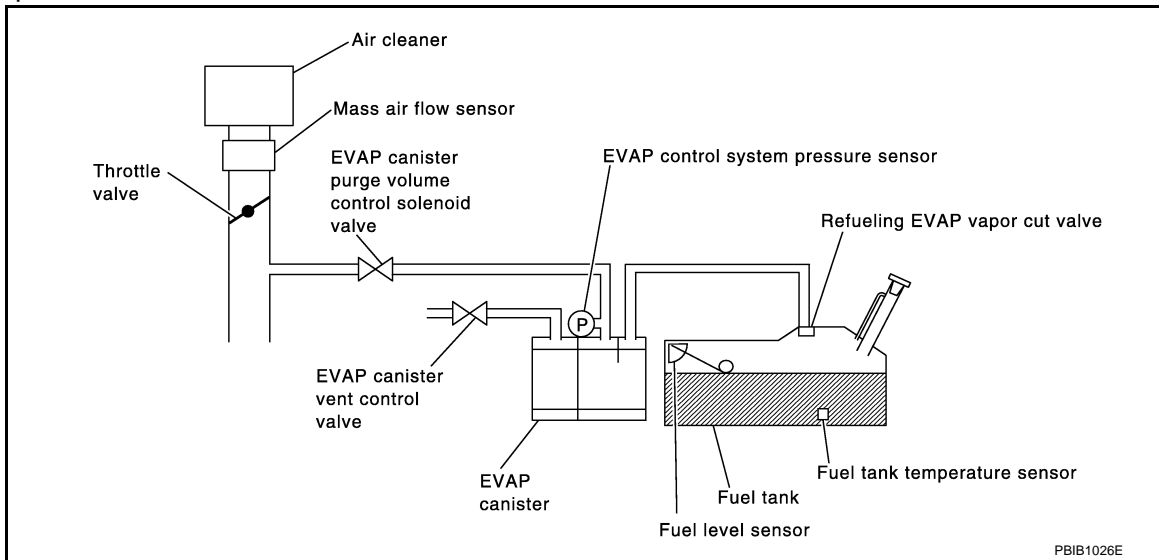

DTC No.	Trouble diagnosis name	DTC detecting condition	Possible cause
P0441	EVAP control system incorrect purge flow	EVAP control system does not operate properly, EVAP control system has a leak between intake manifold and EVAP control system pressure sensor.	<ul style="list-style-type: none"> • EVAP canister purge volume control solenoid valve stuck closed • EVAP control system pressure sensor and the circuit • Loose, disconnected or improper connection of rubber tube • Blocked rubber tube • Cracked EVAP canister • EVAP canister purge volume control solenoid valve circuit • Accelerator pedal position sensor • Blocked purge port • EVAP canister vent control valve

DTC CONFIRMATION PROCEDURE

1. INSPECTION START

Do you have CONSULT-III?

Do you have CONSULT-III?

YES >> GO TO 2.

NO >> GO TO 6.

2. PRECONDITIONING

If DTC Confirmation Procedure has been previously conducted, always perform the following procedure before conducting the next test.

1. Turn ignition switch OFF and wait at least 10 seconds.

P0441 EVAP CONTROL SYSTEM

[VQ37VHR]

< DTC/CIRCUIT DIAGNOSIS >

2. Turn ignition switch ON.
3. Turn ignition switch OFF and wait at least 10 seconds.

TESTING CONDITION:

Always perform test at a temperature of 5°C (41°F) or more.

>> GO TO 3.

3.PERFORM DTC CONFIRMATION PROCEDURE-I

Ⓜ With CONSULT-III

1. Start engine and warm it up to normal operating temperature.
2. Turn ignition switch OFF and wait at least 10 seconds.
3. Turn ignition switch ON.
4. Turn ignition switch OFF and wait at least 10 seconds.
5. Start engine and let it idle for at least 70 seconds.
6. Select "PURG FLOW P0441" of "EVAPORATIVE SYSTEM" in "DTC WORK SUPPORT" mode with CONSULT-III.
7. Touch "START".

Is "COMPLETED" displayed on CONSULT-III screen?

- YES >> GO TO 5.
NO >> GO TO 4.

4.PERFORM DTC CONFIRMATION PROCEDURE-II

When the following conditions are met, "TESTING" will be displayed on the CONSULT-III screen. Maintain the conditions continuously until "TESTING" changes to "COMPLETED". (It will take at least 35 seconds.)

Selector lever	Suitable position
VHCL SPEED SE	32 - 120 km/h (20 - 75 mph)
ENG SPEED	500 - 3,000 rpm
B/FUEL SCHDL	1.3 - 9.0 msec
COOLAN TEMP/S	More than 0°C (32°F)

CAUTION:

Always drive vehicle at a safe speed.

Is "COMPLETED" displayed on CONSULT-III screen?

- YES >> GO TO 5.
NO >> Perform DTC CONFIRMATION PROCEDURE again. GO TO 3.

5.PERFORM DTC CONFIRMATION PROCEDURE-III

Touch "SELF-DIAG RESULTS".

Which is displayed on CONSULT-III screen?

- OK >> INSPECTION END
NG >> Go to [EC-284, "Diagnosis Procedure"](#).

6.PERFORM COMPONENT FUNCTION CHECK

Perform component function check. Refer to [EC-283, "Component Function Check"](#).

NOTE:

Use component function check to check the overall monitoring function of the EVAP control system purge flow monitoring. During this check, a 1st trip DTC might not be confirmed.

Is the inspection result normal?

- YES >> INSPECTION END
NO >> Go to [EC-284, "Diagnosis Procedure"](#).

Component Function Check

INFOID:000000005151828

1.PERFORM COMPONENT FUNCTION CHECK

Ⓧ Without CONSULT-III

1. Lift up drive wheels.

P0441 EVAP CONTROL SYSTEM

[VQ37VHR]

< DTC/CIRCUIT DIAGNOSIS >

2. Start engine (VDC switch OFF) and warm it up to normal operating temperature.
3. Turn ignition switch OFF and wait at least 10 seconds.
4. Turn ignition switch ON.
5. Turn ignition switch OFF and wait at least 10 seconds.
6. Start engine and wait at least 70 seconds.
7. Set voltmeter probes to ECM harness connector terminals as per the following.

ECM		
Connector	+	-
	Terminal	Terminal
M107	102 (EVAP control system pressure sensor signal)	112

8. Check EVAP control system pressure sensor value at idle speed and note it.
9. Establish and maintain the following conditions for at least 1 minute.

Air conditioner switch	ON
Headlamp switch	ON
Rear window defogger switch	ON
Engine speed	Approx. 3,000 rpm
Gear position	Any position other than P, N or R

10. Verify that EVAP control system pressure sensor value stays 0.1 V less than the value at idle speed (measured at step 8) for at least 1 second.

Is the inspection result normal?

- YES >> INSPECTION END
NO >> Go to [EC-284, "Diagnosis Procedure"](#).

Diagnosis Procedure

INFOID:000000005151829

1. CHECK EVAP CANISTER

1. Turn ignition switch OFF.
2. Check EVAP canister for cracks.

Is the inspection result normal?

- YES-1 >> With CONSULT-III: GO TO 2.
YES-2 >> Without CONSULT-III: GO TO 3.
NO >> Replace EVAP canister.

2. CHECK PURGE FLOW

With CONSULT-III

1. Disconnect vacuum hose connected to EVAP canister purge volume control solenoid valve at EVAP service port.
2. Start engine and let it idle.
3. Select "PURG VOL CONT/V" in "ACTIVE TEST" mode with CONSULT-III.
4. Touch "Qd" and "Qu" on CONSULT-III screen to adjust "PURG VOL C/V" opening and check vacuum existence.

PURG VOL C/V	Vacuum
100%	Existed
0%	Not existed

Is the inspection result normal?

- YES >> GO TO 7.
NO >> GO TO 4.

3. CHECK PURGE FLOW

Without CONSULT-III

P0441 EVAP CONTROL SYSTEM

[VQ37VHR]

< DTC/CIRCUIT DIAGNOSIS >

1. Start engine and warm it up to normal operating temperature.
2. Stop engine.
3. Disconnect vacuum hose connected to EVAP canister purge volume control solenoid valve at EVAP service port and install vacuum gauge. For the location of EVAP service port, refer to [EC-80. "System Diagram"](#).
4. Start engine and let it idle.
Do not depress accelerator pedal even slightly.
5. Check vacuum gauge indication before 60 seconds passed after starting engine.

Vacuum should not exist.

6. Revving engine up to 2,000rpm after 100 seconds passed after starting engine.

Vacuum should exist.

Is the inspection result normal?

YES >> GO TO 7.

NO >> GO TO 4.

4.CHECK EVAP PURGE LINE

1. Turn ignition switch OFF.
2. Check EVAP purge line for improper connection or disconnection.
Refer to [EC-80. "System Diagram"](#).

Is the inspection result normal?

YES >> GO TO 5.

NO >> Repair it.

5.CHECK EVAP PURGE HOSE AND PURGE PORT

1. Disconnect purge hoses connected to EVAP service port **A** and EVAP canister purge volume control solenoid valve **B**.
2. Blow air into each hose and EVAP purge port **C**.

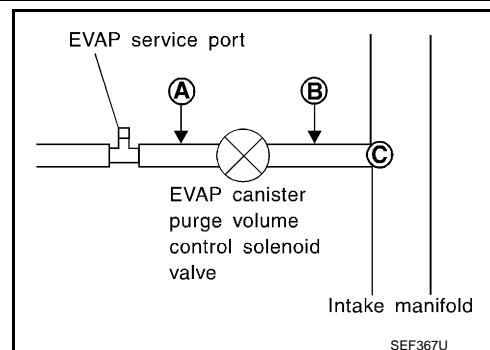

3. Check that air flows freely.

Is the inspection result normal?

YES-1 >> With CONSULT-III: GO TO 6.

YES-2 >> Without CONSULT-III: GO TO 7.

NO >> Repair or clean hoses and/or purge port.

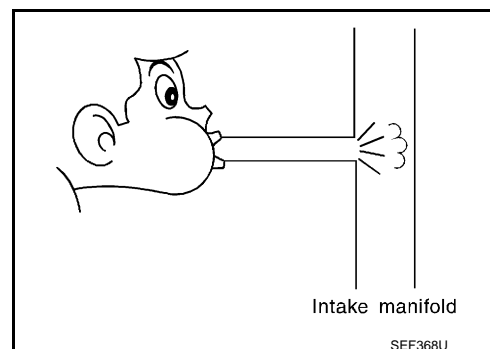

6.CHECK EVAP CANISTER PURGE VOLUME CONTROL SOLENOID VALVE

With CONSULT-III

1. Start engine.
2. Perform "PURG VOL CONT/V" in "ACTIVE TEST" mode with CONSULT-III. Check that engine speed varies according to the valve opening.

Does engine speed vary according to the valve opening?

YES >> GO TO 8.

P0441 EVAP CONTROL SYSTEM

[VQ37VHR]

< DTC/CIRCUIT DIAGNOSIS >

NO >> GO TO 7.

7. CHECK EVAP CANISTER PURGE VOLUME CONTROL SOLENOID VALVE

Refer to [EC-296, "Component Inspection"](#).

Is the inspection result normal?

YES >> GO TO 8.

NO >> Replace EVAP canister purge volume control solenoid valve.

8. CHECK EVAP CONTROL SYSTEM PRESSURE SENSOR CONNECTOR

1. Disconnect EVAP control system pressure sensor harness connector.
2. Check connectors for water.

Water should not exist.

Is the inspection result normal?

YES >> GO TO 9.

NO >> Replace EVAP control system pressure sensor.

9. CHECK EVAP CONTROL SYSTEM PRESSURE SENSOR FUNCTION

Refer to [EC-312, "DTC Logic"](#) for DTC P0452, [EC-317, "DTC Logic"](#) for DTC P0453.

Is the inspection result normal?

YES >> GO TO 10.

NO >> Replace EVAP control system pressure sensor.

10. CHECK RUBBER TUBE FOR CLOGGING

1. Disconnect rubber tube connected to EVAP canister vent control valve.
2. Check the rubber tube for clogging.

Is the inspection result normal?

YES >> GO TO 11.

NO >> Clean the rubber tube using an air blower.

11. CHECK EVAP CANISTER VENT CONTROL VALVE

Refer to [EC-303, "Component Inspection"](#).

Is the inspection result normal?

YES >> GO TO 12.

NO >> Replace EVAP canister vent control valve.

12. CHECK EVAP PURGE LINE

Inspect EVAP purge line (pipe and rubber tube). Check for evidence of leaks.

Refer to [EC-80, "System Diagram"](#).

Is the inspection result normal?

YES >> GO TO 13.

NO >> Replace it.

13. CLEAN EVAP PURGE LINE

Clean EVAP purge line (pipe and rubber tube) using air blower.

>> GO TO 14.

14. CHECK INTERMITTENT INCIDENT

Refer to [GI-36, "Intermittent Incident"](#).

>> INSPECTION END

P0442 EVAP CONTROL SYSTEM

< DTC/CIRCUIT DIAGNOSIS >

[VQ37VHR]

P0442 EVAP CONTROL SYSTEM

DTC Logic

INFOID:000000005151830

DTC DETECTION LOGIC

NOTE:

If DTC P0442 is displayed with DTC P0456, first perform the trouble diagnosis for DTC P0456. Refer to [EC-329, "DTC Logic"](#).

This diagnosis detects leaks in the EVAP purge line using engine intake manifold vacuum.

If pressure does not increase, the ECM will check for leaks in the line between the fuel tank and EVAP canister purge volume control solenoid valve, under the following "Vacuum test" conditions.

The EVAP canister vent control valve is closed to shut the EVAP purge line off. The EVAP canister purge volume control solenoid valve will then be opened to depressurize the EVAP purge line using intake manifold vacuum. After this occurs, the EVAP canister purge volume control solenoid valve will be closed.

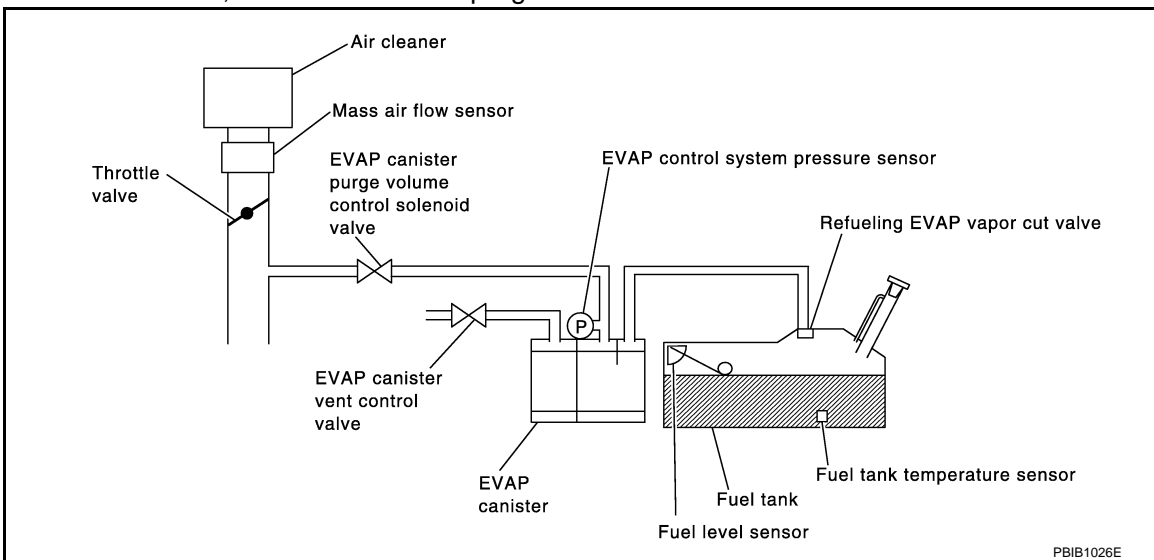

DTC No.	Trouble diagnosis name	DTC detecting condition	Possible cause
P0442	EVAP control system small leak detected (negative pressure)	EVAP control system has a leak, EVAP control system does not operate properly.	<ul style="list-style-type: none"> • Incorrect fuel tank vacuum relief valve • Incorrect fuel filler cap used • Fuel filler cap remains open or fails to close. • Foreign matter caught in fuel filler cap. • Leak is in line between intake manifold and EVAP canister purge volume control solenoid valve. • Foreign matter caught in EVAP canister vent control valve. • EVAP canister or fuel tank leaks • EVAP purge line (pipe and rubber tube) leaks • EVAP purge line rubber tube bent • Loose or disconnected rubber tube • EVAP canister vent control valve and the circuit • EVAP canister purge volume control solenoid valve and the circuit • Fuel tank temperature sensor • O-ring of EVAP canister vent control valve is missing or damaged • EVAP canister is saturated with water • EVAP control system pressure sensor • Fuel level sensor and the circuit • Refueling EVAP vapor cut valve • ORVR system leaks

CAUTION:

- Use only a genuine NISSAN fuel filler cap as a replacement. If an incorrect fuel filler cap is used, the MIL may illuminate.
- If the fuel filler cap is not tightened properly, the MIL may illuminate.

P0442 EVAP CONTROL SYSTEM

[VQ37VHR]

< DTC/CIRCUIT DIAGNOSIS >

- Use only a genuine NISSAN rubber tube as a replacement.

DTC CONFIRMATION PROCEDURE

1. PRECONDITIONING

If DTC Confirmation Procedure has been previously conducted, always perform the following procedure before conducting the next test.

TESTING CONDITION:

- Perform "DTC WORK SUPPORT" when the fuel level is between 1/4 and 3/4 full, and vehicle is placed on flat level surface.
- Always perform test at a temperature of 0 to 30°C (32 to 86°F).

NOTE:

Make sure that EVAP hoses are connected to EVAP canister purge volume control solenoid valve properly.

Do you have CONSULT-III?

YES >> GO TO 2.

NO >> GO TO 3.

2. PERFORM DTC CONFIRMATION PROCEDURE

With CONSULT-III

1. Turn ignition switch ON.
2. Turn ignition switch OFF and wait at least 10 seconds.
3. Turn ignition switch ON and select "DATA MONITOR" mode with CONSULT-III.
4. Make sure that the following conditions are met.
COOLAN TEMP/S: 0 - 70°C (32 - 158°F)
INT/A TEMP SE: 0 - 30°C (32 - 86°F)
5. Select "EVAP SML LEAK P0442/P1442" of "EVAPORATIVE SYSTEM" in "DTC WORK SUPPORT" mode with CONSULT-III.
Follow the instructions displayed on CONSULT-III screen.

NOTE:

If the engine speed cannot be maintained within the range displayed on the CONSULT-III screen, go to [EC-13, "BASIC INSPECTION : Special Repair Requirement"](#).

Which is displayed on CONSULT-III screen?

OK >> INSPECTION END

NG >> Go to [EC-288, "Diagnosis Procedure"](#).

3. PERFORM DTC CONFIRMATION PROCEDURE

With GST

NOTE:

Be sure to read the explanation of Driving Pattern in [EC-561, "How to Set SRT Code"](#) before driving vehicle.

1. Start engine.
2. Drive vehicle according to Driving Pattern,
3. Stop vehicle.
4. Turn ignition switch OFF and wait at least 10 seconds.
5. Turn ignition switch ON.
6. Turn ignition switch OFF and wait at least 10 seconds.
7. Check 1st trip DTC.

Is 1st trip DTC displayed?

YES-1 >> P0441: Go to [EC-284, "Diagnosis Procedure"](#).

YES-2 >> P0442: Go to [EC-288, "Diagnosis Procedure"](#).

NO >> INSPECTION END

Diagnosis Procedure

INFOID:000000005151831

1. CHECK FUEL FILLER CAP DESIGN

1. Turn ignition switch OFF.

P0442 EVAP CONTROL SYSTEM

[VQ37VHR]

< DTC/CIRCUIT DIAGNOSIS >

2. Check for genuine NISSAN fuel filler cap design.

Is the inspection result normal?

YES >> GO TO 2.

NO >> Replace with genuine NISSAN fuel filler cap.

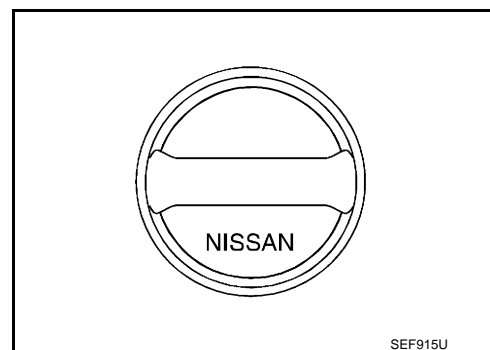

2.CHECK FUEL FILLER CAP INSTALLATION

Check that the cap is tightened properly by rotating the cap clockwise.

Is the inspection result normal?

YES >> GO TO 3.

NO >> Open fuel filler cap, then clean cap and fuel filler neck threads using air blower. Retighten until ratcheting sound is heard.

3.CHECK FUEL FILLER CAP FUNCTION

Check for air releasing sound while opening the fuel filler cap.

Is the inspection result normal?

YES >> GO TO 5.

NO >> GO TO 4.

4.CHECK FUEL TANK VACUUM RELIEF VALVE

Refer to [EC-292. "Component Inspection"](#).

Is the inspection result normal?

YES >> GO TO 5.

NO >> Replace fuel filler cap with a genuine one.

5.CHECK FOR EVAP LEAK

Refer to [EC-608. "Inspection"](#).

Is there any leak in EVAP line?

YES >> Repair or replace.

NO >> GO TO 6.

6.CHECK EVAP CANISTER VENT CONTROL VALVE

Check the following.

- EVAP canister vent control valve is installed properly.

Refer to [EC-610. "Removal and Installation"](#).

- EVAP canister vent control valve.

Refer to [EC-303. "Component Inspection"](#).

Is the inspection result normal?

YES >> GO TO 7.

NO >> Repair or replace EVAP canister vent control valve and O-ring.

7.CHECK IF EVAP CANISTER IS SATURATED WITH WATER

1. Remove EVAP canister with EVAP canister vent control valve and EVAP control system pressure sensor attached.

P0442 EVAP CONTROL SYSTEM

[VQ37VHR]

< DTC/CIRCUIT DIAGNOSIS >

2. Check if water will drain from EVAP canister (1).

2 : EVAP canister vent control valve

Does water drain from the EVAP canister?

YES >> GO TO 8.

NO-1 >> With CONSULT-III: GO TO 10.

NO-2 >> Without CONSULT-III: GO TO 11.

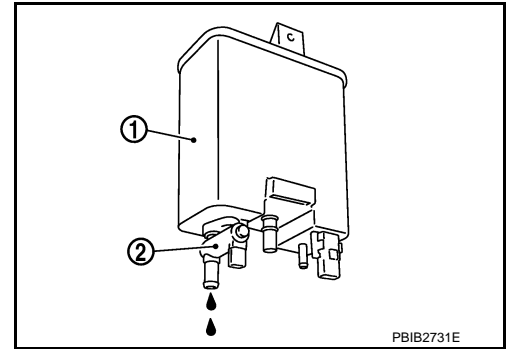

8. CHECK EVAP CANISTER

Weigh the EVAP canister with the EVAP canister vent control valve and EVAP control system pressure sensor attached.

The weight should be less than 2.2 kg (4.9 lb).

Is the inspection result normal?

YES-1 >> With CONSULT-III: GO TO 10.

YES-2 >> Without CONSULT-III: GO TO 11.

NO >> GO TO 9.

9. DETECT MALFUNCTIONING PART

Check the following.

- EVAP canister for damage
- EVAP hose between EVAP canister and vehicle frame for clogging or poor connection

>> Repair hose or replace EVAP canister.

10. CHECK EVAP CANISTER PURGE VOLUME CONTROL SOLENOID VALVE OPERATION

With CONSULT-III

1. Disconnect vacuum hose connected to EVAP canister purge volume control solenoid valve at EVAP service port.
2. Start engine and let it idle.
3. Select "PURG VOL CONT/V" in "ACTIVE TEST" mode.
4. Touch "Qu" on CONSULT-III screen to increase "PURG VOL C/V" opening to 100%.
5. Check vacuum hose for vacuum.

Vacuum should exist.

Is the inspection result normal?

YES >> GO TO 13.

NO >> GO TO 12.

11. CHECK EVAP CANISTER PURGE VOLUME CONTROL SOLENOID VALVE OPERATION

Without CONSULT-III

1. Start engine and warm it up to normal operating temperature.
2. Stop engine.
3. Disconnect vacuum hose connected to EVAP canister purge volume control solenoid valve at EVAP service port.
4. Start engine and let it idle for at least 80 seconds.
5. Check vacuum hose for vacuum when revving engine up to 2,000 rpm.

Vacuum should exist.

Is the inspection result normal?

YES >> GO TO 13.

NO >> GO TO 12.

12. CHECK VACUUM HOSE

Check vacuum hoses for clogging or disconnection. Refer to [EC-80, "System Diagram"](#).

P0442 EVAP CONTROL SYSTEM

[VQ37VHR]

< DTC/CIRCUIT DIAGNOSIS >

Is the inspection result normal?

YES >> GO TO 13.

NO >> Repair or reconnect the hose.

13.CHECK EVAP CANISTER PURGE VOLUME CONTROL SOLENOID VALVE

Refer to [EC-296, "Component Inspection"](#).

Is the inspection result normal?

YES >> GO TO 14.

NO >> Replace EVAP canister purge volume control solenoid valve.

14.CHECK FUEL TANK TEMPERATURE SENSOR

Refer to [EC-246, "Component Inspection"](#).

Is the inspection result normal?

YES >> GO TO 15.

NO >> Replace fuel level sensor unit.

15.CHECK EVAP CONTROL SYSTEM PRESSURE SENSOR

Refer to [EC-311, "Component Inspection"](#).

Is the inspection result normal?

YES >> GO TO 16.

NO >> Replace EVAP control system pressure sensor.

16.CHECK EVAP PURGE LINE

Check EVAP purge line (pipe, rubber tube, fuel tank and EVAP canister) for cracks or improper connection.

Refer to [EC-80, "System Diagram"](#).

Is the inspection result normal?

YES >> GO TO 17.

NO >> Repair or reconnect the hose.

17.CLEAN EVAP PURGE LINE

Clean EVAP purge line (pipe and rubber tube) using air blower.

>> GO TO 18.

18.CHECK EVAP/ORVR LINE

Check EVAP/ORVR line between EVAP canister and fuel tank for clogging, kinks, looseness and improper connection. For location, refer to [EC-509, "Description"](#).

Is the inspection result normal?

YES >> GO TO 19.

NO >> Repair or replace hoses and tubes.

19.CHECK RECIRCULATION LINE

Check recirculation line between filler neck tube and fuel tank for clogging, kinks, cracks, looseness and improper connection.

Is the inspection result normal?

YES >> GO TO 20.

NO >> Repair or replace hose, tube or filler neck tube.

20.CHECK REFUELING EVAP VAPOR CUT VALVE

Refer to [EC-512, "Component Inspection"](#).

Is the inspection result normal?

YES >> GO TO 21.

NO >> Replace refueling EVAP vapor cut valve with fuel tank.

21.CHECK FUEL LEVEL SENSOR

Refer to [MWI-54, "Component Inspection"](#).

Is the inspection result normal?

P0442 EVAP CONTROL SYSTEM

[VQ37VHR]

< DTC/CIRCUIT DIAGNOSIS >

- YES >> GO TO 22.
NO >> Replace fuel level sensor unit.

22.CHECK INTERMITTENT INCIDENT

Refer to [GI-36. "Intermittent Incident"](#).

>> INSPECTION END

Component Inspection

INFOID:000000005151832

1.CHECK FUEL TANK VACUUM RELIEF VALVE

1. Turn ignition switch OFF.
2. Remove fuel filler cap.
3. Wipe clean valve housing.

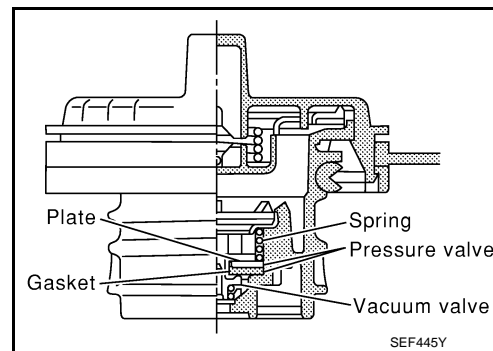

4. Check valve opening pressure and vacuum.

Pressure: 15.3 - 20.0 kPa (0.156 - 0.204 kg/cm², 2.22 - 2.90 psi)

Vacuum: -6.0 to -3.3 kPa (-0.061 to -0.034 kg/cm², -0.87 to -0.48 psi)

Is the inspection result normal?

- YES >> INSPECTION END
NO >> GO TO 2.

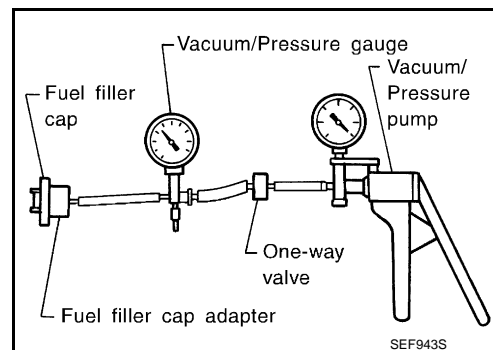

2.REPLACE FUEL FILLER CAP

Replace fuel filler cap.

CAUTION:

Use only a genuine fuel filler cap as a replacement. If an incorrect fuel filler cap is used, the MIL may illuminate.

>> INSPECTION END

P0443 EVAP CANISTER PURGE VOLUME CONTROL SOLENOID VALVE

< DTC/CIRCUIT DIAGNOSIS >

[VQ37VHR]

P0443 EVAP CANISTER PURGE VOLUME CONTROL SOLENOID VALVE

Description

INFOID:000000005151833

The EVAP canister purge volume control solenoid valve is used to control the flow rate of fuel vapor from the EVAP canister. The EVAP canister purge volume control solenoid valve is moved by ON/OFF pulses from the ECM. The longer the ON pulse, the greater the amount of fuel vapor that will flow through the valve.

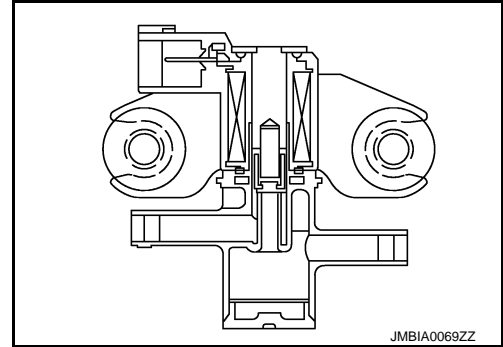

DTC Logic

INFOID:000000005151834

DTC DETECTION LOGIC

DTC No.	Trouble diagnosis name	DTC detecting condition	Possible cause
P0443	EVAP canister purge volume control solenoid valve	The canister purge flow is detected during the specified driving conditions, even when EVAP canister purge volume control solenoid valve is completely closed.	<ul style="list-style-type: none"> • EVAP control system pressure sensor • EVAP canister purge volume control solenoid valve (The valve is stuck open.) • EVAP canister vent control valve • EVAP canister • Hoses (Hoses are connected incorrectly or clogged.)

DTC CONFIRMATION PROCEDURE

1. PRECONDITIONING

If DTC Confirmation Procedure has been previously conducted, always perform the following procedure before conducting the next test.

1. Turn ignition switch OFF and wait at least 10 seconds.
2. Turn ignition switch ON.
3. Turn ignition switch OFF and wait at least 10 seconds.

TESTING CONDITION:

Always perform test at a temperature of 5°C (41°F) or more.

Do you have CONSULT-III

- YES >> GO TO 2.
NO >> GO TO 3.

2. PERFORM DTC CONFIRMATION PROCEDURE

With CONSULT-III

1. Start engine and warm it up to normal operating temperature.
2. Turn ignition switch OFF and wait at least 10 seconds.
3. Turn ignition switch ON.
4. Turn ignition switch OFF and wait at least 10 seconds.
5. Turn ignition switch ON.
6. Select "PURG VOL CN/V P1444" of "EVAPORATIVE SYSTEM" in "DTC WORK SUPPORT" mode with CONSULT-III.
7. Touch "START".
8. Start engine and let it idle until "TESTING" on CONSULT-III changes to "COMPLETED". (It will take approximately 10 seconds.)
If "TESTING" is not displayed after 5 minutes, retry from step 2.
9. Touch "SELF-DIAG RESULTS".

Which is displayed on CONSULT-III screen?

P0443 EVAP CANISTER PURGE VOLUME CONTROL SOLENOID VALVE

[VQ37VHR]

< DTC/CIRCUIT DIAGNOSIS >

- OK >> INSPECTION END
NG >> Go to [EC-294, "Diagnosis Procedure"](#).

3.PERFORM DTC CONFIRMATION PROCEDURE

With GST

1. Start engine and warm it up to normal operating temperature.
2. Turn ignition switch OFF and wait at least 10 seconds.
3. Turn ignition switch ON.
4. Turn ignition switch OFF and wait at least 10 seconds.
5. Start engine and let it idle for at least 20 seconds.
6. Check 1st trip DTC.

Is 1st trip DTC displayed?

- YES >> Go to [EC-294, "Diagnosis Procedure"](#).
NO >> INSPECTION END

Diagnosis Procedure

INFOID:000000005151835

1.CHECK EVAP CANISTER PURGE VOLUME CONTROL SOLENOID VALVE POWER SUPPLY CIRCUIT

1. Turn ignition switch OFF.
2. Disconnect EVAP canister purge volume control solenoid valve harness connector.
3. Turn ignition switch ON.
4. Check the voltage between EVAP canister purge volume control solenoid valve harness connector and ground.

EVAP canister purge volume control solenoid valve		Ground	Voltage
Connector	Terminal		
F7	1	Ground	Battery voltage

Is the inspection result normal?

- YES >> GO TO 3.
NO >> GO TO 2.

2.DETECT MALFUNCTIONING PART

Check the following.

- Harness connectors E106, M6
- Harness connectors M116, F103
- Harness for open or short between EVAP canister purge volume control solenoid valve and IPDM E/R
- Harness for open or short between EVAP canister purge volume control solenoid valve and ECM

>> Repair open circuit, short to ground or short to power in harness or connectors.

3.CHECK EVAP CANISTER PURGE VOLUME CONTROL SOLENOID VALVE OUTPUT SIGNAL CIRCUIT FOR OPEN AND SHORT

1. Turn ignition switch OFF.
2. Disconnect ECM harness connector.
3. Check the continuity between EVAP canister purge volume control solenoid valve harness connector and ECM harness connector.

EVAP canister purge volume control solenoid valve		ECM		Continuity
Connector	Terminal	Connector	Terminal	
F7	2	F101	21	Existed

4. Also check harness for short to ground and short to power.

Is the inspection result normal?

- YES >> GO TO 4.
NO >> Repair open circuit, short to ground or short to power in harness or connectors.

4.CHECK EVAP CONTROL SYSTEM PRESSURE SENSOR CONNECTOR

P0443 EVAP CANISTER PURGE VOLUME CONTROL SOLENOID VALVE

[VQ37VHR]

< DTC/CIRCUIT DIAGNOSIS >

1. Disconnect EVAP control system pressure sensor harness connector.
2. Check connectors for water.

A

Water should not exist.

Is the inspection result normal?

- YES >> GO TO 5.
NO >> Replace EVAP control system pressure sensor.

EC

5.CHECK EVAP CONTROL SYSTEM PRESSURE SENSOR

C

Refer to [EC-311, "Component Inspection"](#).

Is the inspection result normal?

- YES-1 >> With CONSULT-III: GO TO 6.
YES-2 >> Without CONSULT-III: GO TO 7.
NO >> Replace EVAP control system pressure sensor.

D

E

6.CHECK EVAP CANISTER PURGE VOLUME CONTROL SOLENOID VALVE

 **With CONSULT-III**

1. Turn ignition switch OFF.
2. Reconnect harness connectors disconnected.
3. Start engine.
4. Perform "PURG VOL CONT/V" in "ACTIVE TEST" mode with CONSULT-III. Check that engine speed varies according to the valve opening.

F

G

Does engine speed vary according to the valve opening?

- YES >> GO TO 8.
NO >> GO TO 7.

H

7.CHECK EVAP CANISTER PURGE VOLUME CONTROL SOLENOID VALVE

Refer to [EC-296, "Component Inspection"](#).

Is the inspection result normal?

- YES >> GO TO 8.
NO >> Replace EVAP canister purge volume control solenoid valve.

I

J

8.CHECK RUBBER TUBE FOR CLOGGING

1. Disconnect rubber tube connected to EVAP canister vent control valve.
2. Check the rubber tube for clogging.

K

Is the inspection result normal?

- YES >> GO TO 9.
NO >> Clean the rubber tube using an air blower.

L

9.CHECK EVAP CANISTER VENT CONTROL VALVE

Refer to [EC-303, "Component Inspection"](#).

Is the inspection result normal?

- YES >> GO TO 10.
NO >> Replace EVAP canister vent control valve.

M

N

10.CHECK IF EVAP CANISTER IS SATURATED WITH WATER

1. Remove EVAP canister with EVAP canister vent control valve and EVAP control system pressure sensor attached.

O

P

P0443 EVAP CANISTER PURGE VOLUME CONTROL SOLENOID VALVE

< DTC/CIRCUIT DIAGNOSIS >

[VQ37VHR]

2. Check if water will drain from EVAP canister (1).

2 : EVAP canister vent control valve

Does water drain from the EVAP canister?

- YES >> GO TO 11.
NO >> GO TO 13.

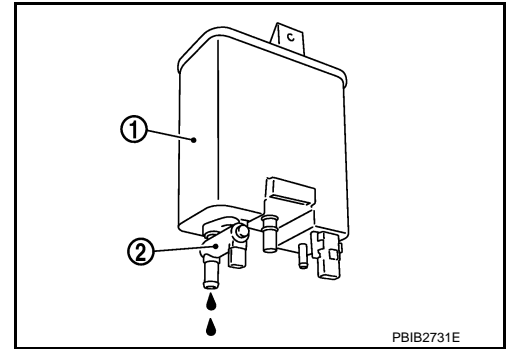

11. CHECK EVAP CANISTER

Weigh the EVAP canister with the EVAP canister vent control valve and EVAP control system pressure sensor attached.

The weight should be less than 2.2 kg (4.9 lb).

Is the inspection result normal?

- YES >> GO TO 13.
NO >> GO TO 12.

12. DETECT MALFUNCTIONING PART

Check the following.

- EVAP canister for damage
- EVAP hose between EVAP canister and vehicle frame for clogging or poor connection

>> Repair hose or replace EVAP canister.

13. CHECK INTERMITTENT INCIDENT

Refer to [GI-36, "Intermittent Incident"](#).

>> INSPECTION END

Component Inspection

INFOID:000000005151836

1. CHECK EVAP CANISTER PURGE VOLUME CONTROL SOLENOID VALVE

① With CONSULT-III

1. Turn ignition switch OFF.
2. Reconnect all harness connectors disconnected.
3. Disconnect EVAP purge hoses connected to EVAP canister purge volume control solenoid valve.
4. Turn ignition switch ON.
5. Select "PURG VOL CONT/V" in "ACTIVE TEST" mode with CONSULT-III.
6. Touch "Qd" and "Qu" on CONSULT-III screen to adjust "PURG VOL C/V" opening and check air passage continuity of EVAP canister purge volume control solenoid valve under the following conditions.

Condition (PURG VOL C/V value)	Air passage continuity between (A) and (B)
100%	Existed
0%	Not existed

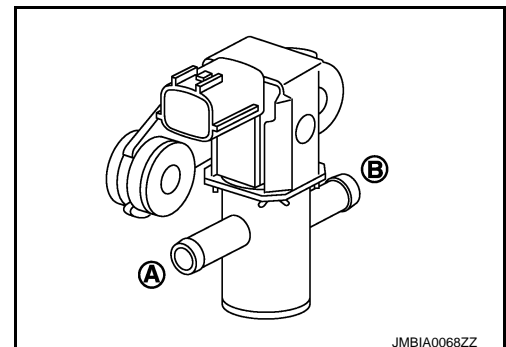

② Without CONSULT-III

1. Turn ignition switch OFF.
2. Disconnect EVAP canister purge volume control solenoid valve harness connector.
3. Disconnect EVAP purge hoses connected to EVAP canister purge volume control solenoid valve.

P0443 EVAP CANISTER PURGE VOLUME CONTROL SOLENOID VALVE

< DTC/CIRCUIT DIAGNOSIS >

[VQ37VHR]

4. Check air passage continuity of EVAP canister purge volume control solenoid valve under the following conditions.

Condition	Air passage continuity between (A) and (B)
12V direct current supply between terminals 1 and 2	Existed
No supply	Not existed

Is the inspection result normal?

YES >> INSPECTION END

NO >> Replace EVAP canister purge volume control solenoid valve

A

EC

C

D

E

F

G

H

I

J

K

L

M

N

O

P

P0444, P0445 EVAP CANISTER PURGE VOLUME CONTROL SOLENOID VALVE

[VQ37VHR]

< DTC/CIRCUIT DIAGNOSIS >

P0444, P0445 EVAP CANISTER PURGE VOLUME CONTROL SOLENOID VALVE

Description

INFOID:000000005151837

The EVAP canister purge volume control solenoid valve is used to control the flow rate of fuel vapor from the EVAP canister. The EVAP canister purge volume control solenoid valve is moved by ON/OFF pulses from the ECM. The longer the ON pulse, the greater the amount of fuel vapor that will flow through the valve.

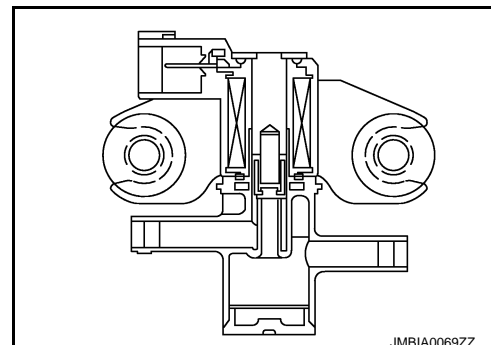

DTC Logic

INFOID:000000005151838

DTC DETECTION LOGIC

DTC No.	Trouble diagnosis name	DTC detecting condition	Possible cause
P0444	EVAP canister purge volume control solenoid valve circuit open	An excessively low voltage signal is sent to ECM through the valve	<ul style="list-style-type: none">• Harness or connectors (The solenoid valve circuit is open or shorted.)• EVAP canister purge volume control solenoid valve
P0445	EVAP canister purge volume control solenoid valve circuit shorted	An excessively high voltage signal is sent to ECM through the valve	<ul style="list-style-type: none">• Harness or connectors (The solenoid valve circuit is shorted.)• EVAP canister purge volume control solenoid valve

DTC CONFIRMATION PROCEDURE

1.CONDITIONING

If DTC Confirmation Procedure has been previously conducted, always perform the following procedure before conducting the next test.

1. Turn ignition switch OFF and wait at least 10 seconds.
2. Turn ignition switch ON.
3. Turn ignition switch OFF and wait at least 10 seconds.

TESTING CONDITION:

Before performing the following procedure, confirm battery voltage is more than 11 V at idle.

>> GO TO 2.

2.PERFORM DTC CONFIRMATION PROCEDURE

1. Start engine and let it idle for at least 13 seconds.
2. Check 1st trip DTC.

Is 1st trip DTC detected?

- YES >> Go to [EC-298. "Diagnosis Procedure"](#).
NO >> INSPECTION END

Diagnosis Procedure

INFOID:000000005151839

1.CHECK EVAP CANISTER PURGE VOLUME CONTROL SOLENOID VALVE POWER SUPPLY CIRCUIT

1. Turn ignition switch OFF.
2. Disconnect EVAP canister purge volume control solenoid valve harness connector.
3. Turn ignition switch ON.

P0444, P0445 EVAP CANISTER PURGE VOLUME CONTROL SOLENOID VALVE

[VQ37VHR]

< DTC/CIRCUIT DIAGNOSIS >

4. Check the voltage between EVAP canister purge volume control solenoid valve harness connector and ground.

EVAP canister purge volume control solenoid valve		Ground	Voltage
Connector	Terminal		
F7	1	Ground	Battery voltage

Is the inspection result normal?

YES >> GO TO 3.

NO >> GO TO 2.

2. DETECT MALFUNCTIONING PART

Check the following.

- Harness connectors E106, M6
- Harness connectors M116, F103
- Harness for open or short between EVAP canister purge volume control solenoid valve and IPDM E/R
- Harness for open or short between EVAP canister purge volume control solenoid valve and ECM

>> Repair open circuit, short to ground or short to power in harness or connectors.

3. CHECK EVAP CANISTER PURGE VOLUME CONTROL SOLENOID VALVE OUTPUT SIGNAL CIRCUIT FOR OPEN AND SHORT

1. Turn ignition switch OFF.
2. Disconnect ECM harness connector.
3. Check the continuity between EVAP canister purge volume control solenoid valve harness connector and ECM harness connector.

EVAP canister purge volume control solenoid valve		ECM		Continuity
Connector	Terminal	Connector	Terminal	
F7	2	F101	21	Existed

4. Also check harness for short to ground and short to power.

Is the inspection result normal?

YES-1 >> With CONSULT-III: GO TO 4.

YES-2 >> Without CONSULT-III: GO TO 5.

NO >> Repair open circuit, short to ground or short to power in harness or connectors.

4. CHECK EVAP CANISTER PURGE VOLUME CONTROL SOLENOID VALVE OPERATION

Ⓜ With CONSULT-III

1. Reconnect all harness connectors disconnected.
2. Start engine.
3. Perform "PURG VOL CONT/V" in "ACTIVE TEST" mode with CONSULT-III. Check that engine speed varies according to the valve opening.

Does engine speed vary according to the valve opening?

YES >> GO TO 6.

NO >> GO TO 5.

5. CHECK EVAP CANISTER PURGE VOLUME CONTROL SOLENOID VALVE

Refer to [EC-300. "Component Inspection"](#).

Is the inspection result normal?

YES >> GO TO 6.

NO >> Replace EVAP canister purge volume control solenoid valve.

6. CHECK INTERMITTENT INCIDENT

Refer to [GI-36. "Intermittent Incident"](#).

P0444, P0445 EVAP CANISTER PURGE VOLUME CONTROL SOLENOID VALVE

< DTC/CIRCUIT DIAGNOSIS >

[VQ37VHR]

>> INSPECTION END

Component Inspection

INFOID:000000005151840

1. CHECK EVAP CANISTER PURGE VOLUME CONTROL SOLENOID VALVE

With CONSULT-III

1. Turn ignition switch OFF.
2. Reconnect all harness connectors disconnected.
3. Disconnect EVAP purge hoses connected to EVAP canister purge volume control solenoid valve.
4. Turn ignition switch ON.
5. Select "PURG VOL CONT/V" in "ACTIVE TEST" mode with CONSULT-III.
6. Touch "Qd" and "Qu" on CONSULT-III screen to adjust "PURG VOL C/V" opening and check air passage continuity of EVAP canister purge volume control solenoid valve under the following conditions.

Condition (PURG VOL C/V value)	Air passage continuity between (A) and (B)
100%	Existed
0%	Not existed

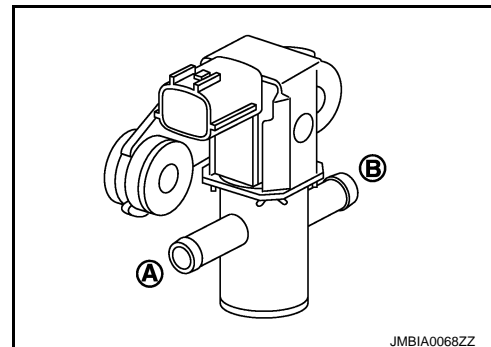

Without CONSULT-III

1. Turn ignition switch OFF.
2. Disconnect EVAP canister purge volume control solenoid valve harness connector.
3. Disconnect EVAP purge hoses connected to EVAP canister purge volume control solenoid valve.
4. Check air passage continuity of EVAP canister purge volume control solenoid valve under the following conditions.

Condition	Air passage continuity between (A) and (B)
12 V direct current supply between terminals 1 and 2	Existed
No supply	Not existed

Is the inspection result normal?

YES >> INSPECTION END

NO >> Replace EVAP canister purge volume control solenoid valve

P0447 EVAP CANISTER VENT CONTROL VALVE

[VQ37VHR]

< DTC/CIRCUIT DIAGNOSIS >

P0447 EVAP CANISTER VENT CONTROL VALVE

Description

INFOID:000000005151841

The EVAP canister vent control valve is located on the EVAP canister and is used to seal the canister vent.

This solenoid valve responds to signals from the ECM. When the ECM sends an ON signal, the coil in the solenoid valve is energized. A plunger will then move to seal the canister vent. The ability to seal the vent is necessary for the on board diagnosis of other evaporative emission control system components.

This solenoid valve is used only for diagnosis, and usually remains opened.

When the vent is closed, under normal purge conditions, the evaporative emission control system is depressurized and allows "EVAP Control System" diagnosis.

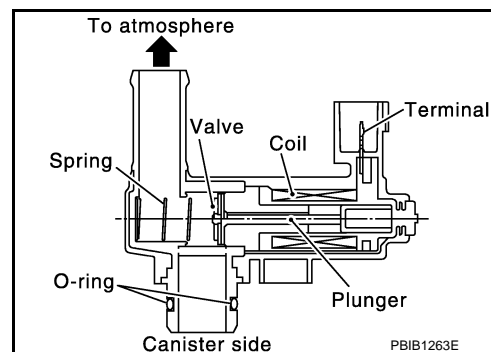

DTC Logic

INFOID:000000005151842

DTC DETECTION LOGIC

DTC No.	Trouble diagnosis name	DTC detecting condition	Possible cause
P0447	EVAP canister vent control valve circuit open	An improper voltage signal is sent to ECM through EVAP canister vent control valve.	<ul style="list-style-type: none">• Harness or connectors (The valve circuit is open or shorted.)• EVAP canister vent control valve

DTC CONFIRMATION PROCEDURE

1. PRECONDITIONING

If DTC Confirmation Procedure has been previously conducted, always perform the following procedure before conducting the next test.

1. Turn ignition switch OFF and wait at least 10 seconds.
2. Turn ignition switch ON.
3. Turn ignition switch OFF and wait at least 10 seconds.

TESTING CONDITION:

Before performing the following procedure, confirm battery voltage is more than 11 V at idle.

>> GO TO 2.

2. PERFORM DTC CONFIRMATION PROCEDURE

1. Start engine and wait at least 8 seconds.
2. Check 1st trip DTC.

Is 1st trip DTC detected?

- YES >> Go to [EC-301. "Diagnosis Procedure"](#).
NO >> INSPECTION END

Diagnosis Procedure

INFOID:000000005151843

1. INSPECTION START

Do you have CONSULT-III?

Do you have CONSULT-III?

- YES >> GO TO 2.
NO >> GO TO 3.

2. CHECK EVAP CANISTER VENT CONTROL VALVE CIRCUIT

With CONSULT-III

1. Turn ignition switch OFF and then ON.
2. Select "VENT CONTROL/V" in "ACTIVE TEST" mode with CONSULT-III.

P0447 EVAP CANISTER VENT CONTROL VALVE

[VQ37VHR]

< DTC/CIRCUIT DIAGNOSIS >

3. Touch "ON/OFF" on CONSULT-III screen.
4. Check for operating sound of the valve.

Clicking sound should be heard.

Is the inspection result normal?

- YES >> GO TO 7.
NO >> GO TO 3.

3.CHECK EVAP CANISTER VENT CONTROL VALVE POWER SUPPLY CIRCUIT

1. Turn ignition switch OFF.
2. Disconnect EVAP canister vent control valve harness connector.
3. Turn ignition switch ON.
4. Check the voltage between EVAP canister vent control valve harness connector and ground.

EVAP canister vent control valve		Ground	Voltage
Connector	Terminal		
B31	1	Ground	Battery voltage

Is the inspection result normal?

- YES >> GO TO 5.
NO >> GO TO 4.

4.DETECT MALFUNCTIONING PART

Check the following.

- Harness connectors E3, F1
- Harness connectors F103, M116
- Harness connectors M7, B1
- Harness for open or short between EVAP canister vent control valve and IPDM E/R

>> Repair open circuit, short to ground or short to power in harness or connectors.

5.CHECK EVAP CANISTER VENT CONTROL VALVE OUTPUT SIGNAL CIRCUIT FOR OPEN AND SHORT

1. Turn ignition switch OFF.
2. Disconnect ECM harness connector.
3. Check the continuity between EVAP canister vent control valve harness connector and ECM harness connector.

EVAP canister vent control valve		ECM		Continuity
Connector	Terminal	Connector	Terminal	
B31	2	M107	121	Existed

4. Also check harness for short to ground and short to power.

Is the inspection result normal?

- YES >> GO TO 7.
NO >> GO TO 6.

6.DETECT MALFUNCTIONING PART

Check the following.

- Harness connectors B1, M7
- Harness for open or short between EVAP canister vent control valve and ECM

>> Repair open circuit, short to ground or short to power in harness or connectors.

7.CHECK RUBBER TUBE FOR CLOGGING

1. Disconnect rubber tube connected to EVAP canister vent control valve.
2. Check the rubber tube for clogging.

P0447 EVAP CANISTER VENT CONTROL VALVE

[VQ37VHR]

< DTC/CIRCUIT DIAGNOSIS >

Is the inspection result normal?

- YES >> GO TO 8.
- NO >> Clean the rubber tube using an air blower.

8. CHECK EVAP CANISTER VENT CONTROL VALVE

Refer to [EC-303, "Component Inspection"](#).

Is the inspection result normal?

- YES >> GO TO 9.
- NO >> Replace EVAP canister vent control valve.

9. CHECK INTERMITTENT INCIDENT

Refer to [GI-36, "Intermittent Incident"](#).

>> INSPECTION END

Component Inspection

INFOID:000000005151844

1. CHECK EVAP CANISTER VENT CONTROL VALVE-I

1. Turn ignition switch OFF.
2. Remove EVAP canister vent control valve from EVAP canister.
3. Check portion (A) of EVAP canister vent control valve for rust.

Is it rusted?

- YES >> Replace EVAP canister vent control valve.
- NO >> GO TO 2.

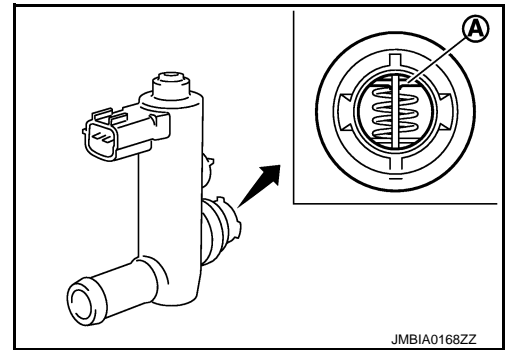

2. CHECK EVAP CANISTER VENT CONTROL VALVE-II

Ⓜ With CONSULT-III

1. Reconnect harness connectors disconnected.
2. Turn ignition switch ON.
3. Perform "VENT CONTROL/V" in "ACTIVE TEST" mode.
4. Check air passage continuity and operation delay time.
Make sure that new O-ring is installed properly.

Condition VENT CONT/V	Air passage continuity between (A) and (B)
ON	Not existed
OFF	Existed

Operation takes less than 1 second.

ⓧ Without CONSULT-III

1. Disconnect EVAP canister vent control valve harness connector.
2. Check air passage continuity and operation delay time under the following conditions.
Make sure that new O-ring is installed properly.

Condition	Air passage continuity between (A) and (B)
12 V direct current supply between terminals 1 and 2	Not existed
OFF	Existed

Operation takes less than 1 second.

Is the inspection result normal?

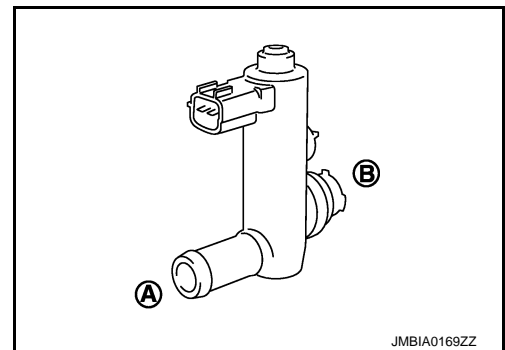

P0447 EVAP CANISTER VENT CONTROL VALVE

[VQ37VHR]

< DTC/CIRCUIT DIAGNOSIS >

- YES >> GO TO 3.
NO >> Replace EVAP canister vent control valve.

3. CHECK EVAP CANISTER VENT CONTROL VALVE-III

④ With CONSULT-III

1. Clean the air passage [portion (A) to (B)] of EVAP canister vent control valve using an air blower.
2. Perform "VENT CONTROL/V" in "ACTIVE TEST" mode.
3. Check air passage continuity and operation delay time.

Make sure that new O-ring is installed properly.

Condition VENT CONT/V	Air passage continuity between (A) and (B)
ON	Not existed
OFF	Existed

Operation takes less than 1 second.

⊗ Without CONSULT-III

1. Clean the air passage [portion (A) to (B)] of EVAP canister vent control valve using an air blower.
2. Check air passage continuity and operation delay time under the following conditions.

Make sure that new O-ring is installed properly.

Condition	Air passage continuity between (A) and (B)
12 V direct current supply between terminals 1 and 2	Not existed
OFF	Existed

Operation takes less than 1 second.

Is the inspection result normal?

- YES >> INSPECTION END
NO >> Replace EVAP canister vent control valve.

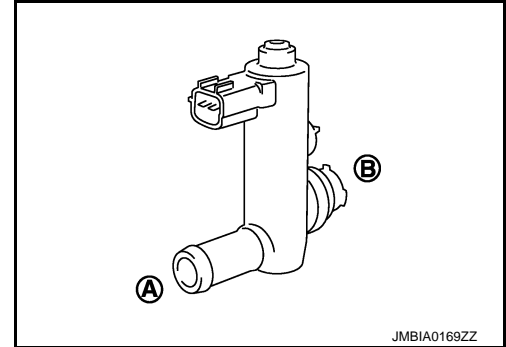

P0448 EVAP CANISTER VENT CONTROL VALVE

[VQ37VHR]

< DTC/CIRCUIT DIAGNOSIS >

P0448 EVAP CANISTER VENT CONTROL VALVE

Description

INFOID:000000005151845

The EVAP canister vent control valve is located on the EVAP canister and is used to seal the canister vent.

This solenoid valve responds to signals from the ECM. When the ECM sends an ON signal, the coil in the solenoid valve is energized. A plunger will then move to seal the canister vent. The ability to seal the vent is necessary for the on board diagnosis of other evaporative emission control system components.

This solenoid valve is used only for diagnosis, and usually remains opened.

When the vent is closed, under normal purge conditions, the evaporative emission control system is depressurized and allows "EVAP Control System" diagnosis.

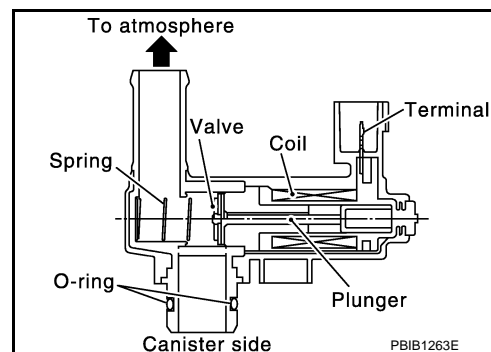

DTC Logic

INFOID:000000005151846

DTC DETECTION LOGIC

DTC No.	Trouble diagnosis name	DTC detecting condition	Possible cause
P0448	EVAP canister vent control valve close	EVAP canister vent control valve remains closed under specified driving conditions.	<ul style="list-style-type: none"> • EVAP canister vent control valve • EVAP control system pressure sensor and the circuit • Blocked rubber tube to EVAP canister vent control valve • EVAP canister is saturated with water

DTC CONFIRMATION PROCEDURE

1. PRECONDITIONING

If DTC Confirmation Procedure has been previously conducted, always perform the following procedure before conducting the next test.

1. Turn ignition switch OFF and wait at least 10 seconds.
2. Turn ignition switch ON.
3. Turn ignition switch OFF and wait at least 10 seconds.

>> GO TO 2.

2. PERFORM DTC CONFIRMATION PROCEDURE

1. Turn ignition switch ON and wait at least 5 seconds.
 2. Turn ignition switch OFF and wait at least 10 seconds.
 3. Start engine and let it idle for at least 1 minute.
 4. Repeat next procedures five times.
 - Increase the engine speed up to between 3,000 and 3,500 rpm and maintain that speed for 2 minutes.
- Do not exceed 2 minutes.**
- Fully released accelerator pedal and keep engine idle for about 5 seconds.
5. Repeat next procedure 27 times.
 - Quickly increase the engine speed up to between 3,000 and 3,500 rpm and maintain that speed for 25 to 30 seconds.

P0448 EVAP CANISTER VENT CONTROL VALVE

[VQ37VHR]

< DTC/CIRCUIT DIAGNOSIS >

- Fully released accelerator pedal and keep engine idle for at least 35 seconds.

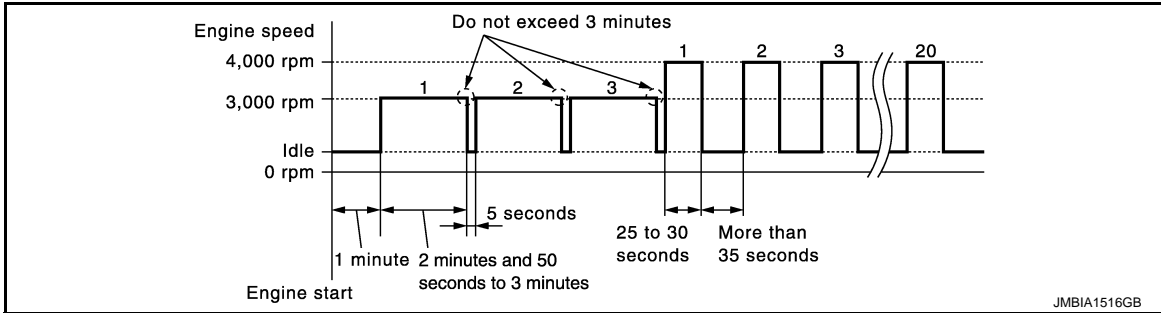

6. Check 1st trip DTC.

Is 1st trip DTC detected?

- YES >> Go to [EC-306. "Diagnosis Procedure"](#).
- NO >> INSPECTION END

Diagnosis Procedure

INFOID:000000005151847

1.CHECK RUBBER TUBE

1. Turn ignition switch OFF.
2. Disconnect rubber tube connected to EVAP canister vent control valve.
3. Check the rubber tube for clogging.

Is the inspection result normal?

- YES >> GO TO 2.
- NO >> Clean rubber tube using an air blower.

2.CHECK EVAP CANISTER VENT CONTROL VALVE

Refer to [EC-307. "Component Inspection"](#).

Is the inspection result normal?

- YES >> GO TO 3.
- NO >> Replace EVAP canister vent control valve.

3.CHECK IF EVAP CANISTER IS SATURATED WITH WATER

1. Remove EVAP canister with EVAP canister vent control valve (2) and EVAP control system pressure sensor attached.
2. Check if water will drain from the EVAP canister (1).

Does water drain from EVAP canister?

- YES >> GO TO 4.
- NO >> GO TO 6.

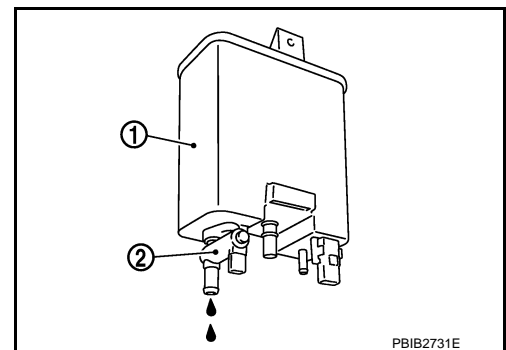

4.CHECK EVAP CANISTER

Weigh the EVAP canister with the EVAP canister vent control valve and EVAP control system pressure sensor attached.

The weight should be less than 2.2 kg (4.9 lb).

Is the inspection result normal?

- YES >> GO TO 6.
- NO >> GO TO 5.

5.DETECT MALFUNCTIONING PART

Check the following.

- EVAP canister for damage
- EVAP hose between EVAP canister and vehicle frame for clogging or poor connection

P0448 EVAP CANISTER VENT CONTROL VALVE

< DTC/CIRCUIT DIAGNOSIS >

[VQ37VHR]

>> Repair hose or replace EVAP canister.

6. CHECK EVAP CONTROL SYSTEM PRESSURE SENSOR CONNECTOR

1. Disconnect EVAP control system pressure sensor harness connector.
2. Check connectors for water.

Water should not exist.

Is the inspection result normal?

- YES >> GO TO 7.
NO >> Replace EVAP control system pressure sensor.

7. CHECK EVAP CONTROL SYSTEM PRESSURE SENSOR

Refer to [EC-311, "Component Inspection"](#).

Is the inspection result normal?

- YES >> GO TO 8.
NO >> Replace EVAP control system pressure sensor.

8. CHECK INTERMITTENT INCIDENT

Refer to [GI-36, "Intermittent Incident"](#).

>> INSPECTION END

Component Inspection

INFOID:000000005151848

1. CHECK EVAP CANISTER VENT CONTROL VALVE-I

1. Turn ignition switch OFF.
2. Remove EVAP canister vent control valve from EVAP canister.
3. Check portion (A) of EVAP canister vent control valve for being rusted.

Is it rusted?

- YES >> Replace EVAP canister vent control valve.
NO >> GO TO 2.

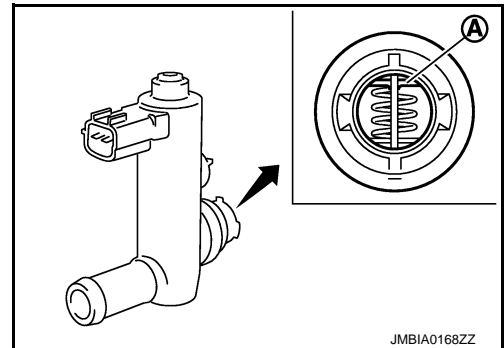

2. CHECK EVAP CANISTER VENT CONTROL VALVE-II

☐ With CONSULT-III

1. Reconnect harness connectors disconnected.
2. Turn ignition switch ON.
3. Perform "VENT CONTROL/V" in "ACTIVE TEST" mode.
4. Check air passage continuity and operation delay time.
Make sure that new O-ring is installed properly.

Condition VENT CONT/V	Air passage continuity between (A) and (B)
ON	Not existed
OFF	Existed

Operation takes less than 1 second.

☒ Without CONSULT-III

1. Disconnect EVAP canister vent control valve harness connector.
2. Check air passage continuity and operation delay time under the following conditions.
Make sure that new O-ring is installed properly.

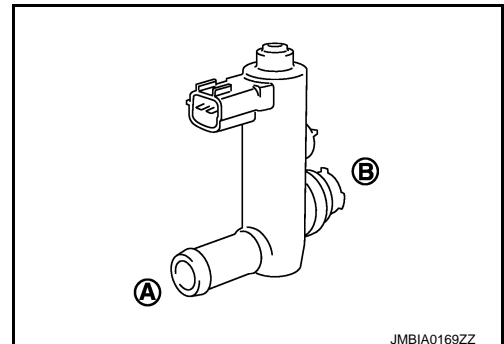

P0448 EVAP CANISTER VENT CONTROL VALVE

< DTC/CIRCUIT DIAGNOSIS >

[VQ37VHR]

Condition	Air passage continuity between (A) and (B)
12 V direct current supply between terminals 1 and 2	Not existed
OFF	Existed

Operation takes less than 1 second.

Is the inspection result normal?

- YES >> INSPECTION END
 NO >> GO TO 3.

3. CHECK EVAP CANISTER VENT CONTROL VALVE-III

④ With CONSULT-III

1. Clean the air passage [portion (A) to (B)] of EVAP canister vent control valve using an air blower.
2. Perform "VENT CONTROL/V" in "ACTIVE TEST" mode.
3. Check air passage continuity and operation delay time.
Make sure that new O-ring is installed properly.

Condition VENT CONT/V	Air passage continuity between (A) and (B)
ON	Not existed
OFF	Existed

Operation takes less than 1 second.

⊗ Without CONSULT-III

1. Clean the air passage [portion (A) to (B)] of EVAP canister vent control valve using an air blower.
2. Check air passage continuity and operation delay time under the following conditions.
Make sure that new O-ring is installed properly.

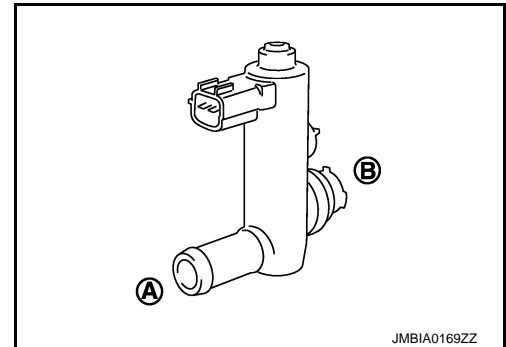

Condition	Air passage continuity between (A) and (B)
12 V direct current supply between terminals 1 and 2	Not existed
OFF	Existed

Operation takes less than 1 second.

Is the inspection result normal?

- YES >> INSPECTION END
 NO >> Replace EVAP canister vent control valve.

P0451 EVAP CONTROL SYSTEM PRESSURE SENSOR

< DTC/CIRCUIT DIAGNOSIS >

[VQ37VHR]

P0451 EVAP CONTROL SYSTEM PRESSURE SENSOR

Description

INFOID:000000005151849

The EVAP control system pressure sensor detects pressure in the purge line. The sensor output voltage to the ECM increases as pressure increases.

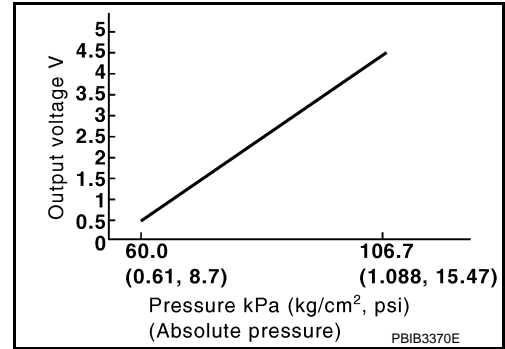

DTC Logic

INFOID:000000005151850

DTC DETECTION LOGIC

DTC No.	Trouble diagnosis name	DTC detecting condition	Possible cause
P0451	EVAP control system pressure sensor performance	ECM detects a sloshing signal from the EVAP control system pressure sensor	<ul style="list-style-type: none"> • Harness or connectors (EVAP control system pressure sensor circuit is shorted.) [CKP sensor (POS) circuit is shorted.] (APP sensor 2 circuit is shorted.) (Refrigerant pressure sensor circuit is shorted.) (Brake booster pressure sensor circuit is shorted) • EVAP control system pressure sensor • Crankshaft position sensor (POS) • Accelerator pedal position sensor • Refrigerant pressure sensor • Brake booster pressure sensor

DTC CONFIRMATION PROCEDURE

1. PRECONDITIONING

If DTC Confirmation Procedure has been previously conducted, always perform the following procedure before conducting the next test.

1. Turn ignition switch OFF and wait at least 10 seconds.
2. Turn ignition switch ON.
3. Turn ignition switch OFF and wait at least 10 seconds.

>> GO TO 2.

2. PERFORM DTC CONFIRMATION PROCEDURE

1. Turn ignition switch OFF and wait at least 10 seconds.
2. Start engine and wait at least 40 seconds.

NOTE:

Do not depress accelerator pedal even slightly.

3. Check 1st trip DTC.

Is 1st trip DTC detected?

YES >> Go to [EC-309, "Diagnosis Procedure"](#).

NO >> INSPECTION END

Diagnosis Procedure

INFOID:000000005151851

1. CHECK GROUND CONNECTION

P0451 EVAP CONTROL SYSTEM PRESSURE SENSOR

[VQ37VHR]

< DTC/CIRCUIT DIAGNOSIS >

1. Turn ignition switch OFF.
2. Check ground connection M95. Refer to Ground Inspection in [GI-39, "Circuit Inspection"](#).

Is the inspection result normal?

- YES >> GO TO 2.
NO >> Repair or replace ground connection.

2.CHECK EVAP CONTROL SYSTEM PRESSURE SENSOR CONNECTOR FOR WATER

1. Disconnect EVAP control system pressure sensor harness connector.
2. Check sensor harness connector for water.

Water should not exist.

Is the inspection result normal?

- YES >> GO TO 3.
NO >> Repair or replace harness connector.

3.CHECK EVAP CONTROL SYSTEM PRESSURE SENSOR POWER SUPPLY CIRCUIT

1. Turn ignition switch ON.
2. Check the voltage between EVAP control system pressure sensor harness connector and ground.

EVAP control system pressure sensor		Ground	Voltage (V)
Connector	Terminal		
B30	3	Ground	Approx. 5

Is the inspection result normal?

- YES >> GO TO 8.
NO >> GO TO 4.

4.CHECK SENSOR POWER SUPPLY CIRCUIT

Check harness for short to power and short to ground, between the following terminals.

ECM		Sensor		
Connector	Terminal	Name	Connector	Terminal
F101	45	Brake booster pressure sensor	E48	1
	46	CKP sensor (POS)	F2	1
M107	103	APP sensor	E112	6
	107	EVAP control system pressure sensor	B30	3
		Refrigerant pressure sensor	E77	3

Is the inspection result normal?

- YES >> GO TO 5.
NO >> Repair short to ground or short to power in harness or connectors.

5.CHECK COMPONENTS

Check the following.

- Crankshaft position sensor (POS) (Refer to [EC-272, "Component Inspection"](#).)
- Brake booster pressure sensor (Refer to [EC-357, "Component Inspection"](#).)
- Refrigerant pressure sensor (Refer to [EC-516, "Diagnosis Procedure"](#).)

Is the inspection result normal?

- YES >> GO TO 6.
NO >> Replace malfunctioning component.

6.CHECK APP SENSOR

Refer to [EC-465, "Component Inspection"](#).

Is the inspection result normal?

- YES >> GO TO 9.

P0451 EVAP CONTROL SYSTEM PRESSURE SENSOR

< DTC/CIRCUIT DIAGNOSIS >

[VQ37VHR]

NO >> GO TO 7.

7. REPLACE ACCELERATOR PEDAL ASSEMBLY

1. Replace accelerator pedal assembly
2. Go to [EC-465. "Special Repair Requirement"](#).

>> INSPECTION END

8. CHECK EVAP CONTROL SYSTEM PRESSURE SENSOR

Refer to [EC-311. "Component Inspection"](#).

Is the inspection result normal?

YES >> GO TO 9.

NO >> Replace EVAP control system pressure sensor.

9. CHECK INTERMITTENT INCIDENT

Refer to [GI-36. "Intermittent Incident"](#).

>> INSPECTION END

Component Inspection

INFOID:000000005151852

1. CHECK EVAP CONTROL SYSTEM PRESSURE SENSOR

1. Turn ignition switch OFF.
2. Remove EVAP control system pressure sensor with its harness connector.
Always replace O-ring with a new one.
3. Install a vacuum pump to EVAP control system pressure sensor.
4. Turn ignition switch ON and check output voltage between ECM harness connector terminals under the following conditions.

ECM			Condition [Applied vacuum kPa (kg/cm ² , psi)]	Voltage (V)
Connector	+	-		
	Terminal	Terminal		
M107	102	112	Not applied	1.8 - 4.8
			-26.7 (-0.272, -3.87)	2.1 to 2.5 lower than above value

CAUTION:

- Always calibrate the vacuum pump gauge when using it.
- Never apply below -93.3 kPa (-0.952 kg/cm², -13.53 psi) or pressure over 101.3 kPa (1.033 kg/cm², 14.69 psi).

Is the inspection result normal?

YES >> INSPECTION END

NO >> Replace EVAP control system pressure sensor

P0452 EVAP CONTROL SYSTEM PRESSURE SENSOR

< DTC/CIRCUIT DIAGNOSIS >

[VQ37VHR]

P0452 EVAP CONTROL SYSTEM PRESSURE SENSOR

Description

INFOID:000000005151853

The EVAP control system pressure sensor detects pressure in the purge line. The sensor output voltage to the ECM increases as pressure increases.

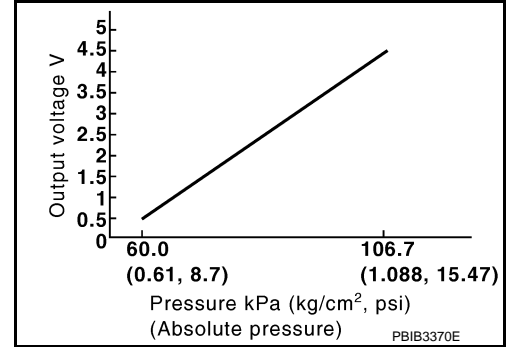

DTC Logic

INFOID:000000005151854

DTC DETECTION LOGIC

DTC No.	Trouble diagnosis name	DTC detecting condition	Possible cause
P0452	EVAP control system pressure sensor low input	An excessively low voltage from the sensor is sent to ECM.	<ul style="list-style-type: none"> • Harness or connectors (EVAP control system pressure sensor circuit is open or shorted.) [CKP sensor (POS) circuit is shorted.] (APP sensor 2 circuit is shorted.) (Refrigerant pressure sensor circuit is shorted.) (Brake booster pressure sensor circuit is shorted) • EVAP control system pressure sensor • Crankshaft position sensor (POS) • Accelerator pedal position sensor • Refrigerant pressure sensor • Brake booster pressure sensor

DTC CONFIRMATION PROCEDURE

1. PRECONDITIONING

If DTC Confirmation Procedure has been previously conducted, always perform the following procedure before conducting the next test.

1. Turn ignition switch OFF and wait at least 10 seconds.
2. Turn ignition switch ON.
3. Turn ignition switch OFF and wait at least 10 seconds.

TESTING CONDITION:

Always perform test at a temperature of 5°C (41°F) or more.

>> GO TO 2.

2. PERFORM DTC CONFIRMATION PROCEDURE

With CONSULT-III

1. Start engine and warm it up to normal operating temperature.
2. Turn ignition switch OFF and wait at least 10 seconds.
3. Turn ignition switch ON.
4. Turn ignition switch OFF and wait at least 10 seconds.
5. Turn ignition switch ON.
6. Select "DATA MONITOR" mode with CONSULT-III.
7. Make sure that "FUEL T/TMP SE" is more than 0°C (32°F).
8. Start engine and wait at least 20 seconds.
9. Check 1st trip DTC.

P0452 EVAP CONTROL SYSTEM PRESSURE SENSOR

[VQ37VHR]

< DTC/CIRCUIT DIAGNOSIS >

With GST

1. Start engine and warm it up to normal operating temperature.
2. Set voltmeter probes to ECM harness connector terminals as per the following.

ECM		
Connector	+	-
	Terminal	Terminal
M107	106 (Fuel tank temperature sensor signal)	128 (ECM ground)

3. Make sure that the voltage is less than 4.2 V.
4. Turn ignition switch OFF and wait at least 10 seconds.
5. Turn ignition switch ON.
6. Turn ignition switch OFF and wait at least 10 seconds.
7. Start engine and wait at least 20 seconds.
8. Check 1st trip DTC.

Is 1st trip DTC detected?

- YES >> Go to [EC-313, "Diagnosis Procedure"](#).
NO >> INSPECTION END

Diagnosis Procedure

INFOID:000000005151855

1. CHECK GROUND CONNECTION

1. Turn ignition switch OFF.
2. Check ground connection M95. Refer to Ground Inspection in [GI-39, "Circuit Inspection"](#).

Is the inspection result normal?

- YES >> GO TO 2.
NO >> Repair or replace ground connection.

2. CHECK CONNECTOR

1. Disconnect EVAP control system pressure sensor harness connector.
2. Check sensor harness connector for water.

Water should not exist.

Is the inspection result normal?

- YES >> GO TO 3.
NO >> Repair or replace harness connector.

3. CHECK EVAP CONTROL SYSTEM PRESSURE SENSOR POWER SUPPLY CIRCUIT-I

1. Turn ignition switch ON.
2. Check the voltage between EVAP control system pressure sensor harness connector and ground.

EVAP control system pressure sensor		Ground	Voltage (V)
Connector	Terminal		
B30	3	Ground	Approx. 5

Is the inspection result normal?

- YES >> GO TO 10.
NO >> GO TO 4.

4. CHECK EVAP CONTROL SYSTEM PRESSURE SENSOR POWER SUPPLY CIRCUIT-II

1. Turn ignition switch OFF.
2. Disconnect ECM harness connector.
3. Check the continuity between EVAP control system pressure sensor harness connector and ECM harness connector.

P0452 EVAP CONTROL SYSTEM PRESSURE SENSOR

< DTC/CIRCUIT DIAGNOSIS >

[VQ37VHR]

EVAP control system pressure sensor		ECM		Continuity
Connector	Terminal	Connector	Terminal	
B30	3	M107	107	Existed

Is the inspection result normal?

YES >> GO TO 6.

NO >> GO TO 5.

5.DETECT MALFUNCTIONING PART

Check the following.

- Harness connectors M7, B1
- Harness for open between ECM and EVAP control system pressure sensor

>> Repair open circuit.

6.CHECK SENSOR POWER SUPPLY CIRCUIT

Check harness for short to power and short to ground, between the following terminals.

ECM		Sensor		
Connector	Terminal	Name	Connector	Terminal
F101	45	Brake booster pressure sensor	E48	1
	46	CKP sensor (POS)	F2	1
M107	103	APP sensor	E112	6
	107	EVAP control system pressure sensor	B30	3
Refrigerant pressure sensor		E77	3	

Is the inspection result normal?

YES >> GO TO 7.

NO >> Repair short to ground or short to power in harness or connectors.

7.CHECK COMPONENTS

Check the following.

- Crankshaft position sensor (POS) (Refer to [EC-272. "Component Inspection".](#))
- Brake booster pressure sensor (Refer to [EC-357. "Component Inspection".](#))
- Refrigerant pressure sensor (Refer to [EC-516. "Diagnosis Procedure".](#))

Is the inspection result normal?

YES >> GO TO 8.

NO >> Replace malfunctioning component.

8.CHECK APP SENSOR

Refer to [EC-465. "Component Inspection".](#)

Is the inspection result normal?

YES >> GO TO 15.

NO >> GO TO 9.

9.REPLACE ACCELERATOR PEDAL ASSEMBLY

1. Replace accelerator pedal assembly
2. Go to [EC-465. "Special Repair Requirement".](#)

>> INSPECTION END

10.CHECK EVAP CONTROL SYSTEM PRESSURE SENSOR GROUND CIRCUIT FOR OPEN AND SHORT

1. Turn ignition switch OFF.

P0452 EVAP CONTROL SYSTEM PRESSURE SENSOR

[VQ37VHR]

< DTC/CIRCUIT DIAGNOSIS >

2. Disconnect ECM harness connector.
3. Check the continuity between EVAP control system pressure sensor harness connector and ECM harness connector.

EVAP control system pressure sensor		ECM		Continuity
Connector	Terminal	Connector	Terminal	
B30	1	M107	112	Existed

4. Also check harness for short to ground and short to power.

Is the inspection result normal?

- YES >> GO TO 12.
NO >> GO TO 11.

11.DETECT MALFUNCTIONING PART

Check the following.

- Harness connectors B1, M7
- Harness for open or short between EVAP control system pressure sensor and ECM

>> Repair open circuit, short to ground or short to power in harness or connectors.

12.CHECK EVAP CONTROL SYSTEM PRESSURE SENSOR INPUT SIGNAL CIRCUIT FOR OPEN AND SHORT

1. Check the continuity between EVAP control system pressure sensor harness connector and ECM harness connector.

EVAP control system pressure sensor		ECM		Continuity
Connector	Terminal	Connector	Terminal	
B30	2	M107	102	Existed

2. Also check harness for short to ground and short to power.

Is the inspection result normal?

- YES >> GO TO 14.
NO >> GO TO 13.

13.DETECT MALFUNCTIONING PART

Check the following.

- Harness connectors B1, M7
- Harness for open or short between EVAP control system pressure sensor and ECM

>> Repair open circuit, short to ground or short to power in harness or connectors.

14.CHECK EVAP CONTROL SYSTEM PRESSURE SENSOR

Refer to [EC-315. "Component Inspection"](#).

Is the inspection result normal?

- YES >> GO TO 15.
NO >> Replace EVAP control system pressure sensor.

15.CHECK INTERMITTENT INCIDENT

Refer to [GI-36. "Intermittent Incident"](#).

>> INSPECTION END

Component Inspection

INFOID:000000005151856

1.CHECK EVAP CONTROL SYSTEM PRESSURE SENSOR

P0452 EVAP CONTROL SYSTEM PRESSURE SENSOR

[VQ37VHR]

< DTC/CIRCUIT DIAGNOSIS >

1. Turn ignition switch OFF.
2. Remove EVAP control system pressure sensor with its harness connector.
Always replace O-ring with a new one.
3. Install a vacuum pump to EVAP control system pressure sensor.
4. Turn ignition switch ON and check output voltage between ECM harness connector terminals under the following conditions.

ECM			Condition [Applied vacuum kPa (kg/cm ² , psi)]	Voltage (V)
Connector	+	-		
	Terminal	Terminal		
M107	102	112	Not applied	1.8 - 4.8
			-26.7 (-0.272, -3.87)	2.1 to 2.5 lower than above value

CAUTION:

- Always calibrate the vacuum pump gauge when using it.
- Never apply below -93.3 kPa (-0.952 kg/cm², -13.53 psi) or pressure over 101.3 kPa (1.033 kg/cm², 14.69 psi).

Is the inspection result normal?

- YES >> INSPECTION END
NO >> Replace EVAP control system pressure sensor

P0453 EVAP CONTROL SYSTEM PRESSURE SENSOR

< DTC/CIRCUIT DIAGNOSIS >

[VQ37VHR]

P0453 EVAP CONTROL SYSTEM PRESSURE SENSOR

Description

INFOID:000000005151857

The EVAP control system pressure sensor detects pressure in the purge line. The sensor output voltage to the ECM increases as pressure increases.

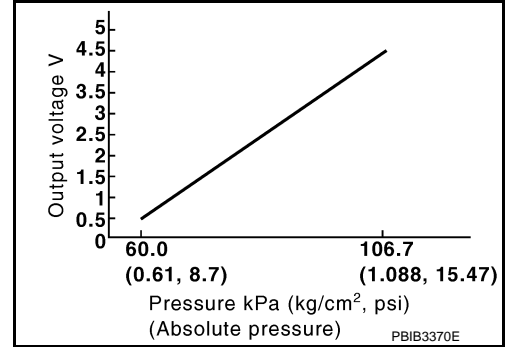

DTC Logic

INFOID:000000005151858

DTC DETECTION LOGIC

DTC No.	Trouble diagnosis name	DTC detecting condition	Possible cause
P0453	EVAP control system pressure sensor high input	An excessively high voltage from the sensor is sent to ECM.	<ul style="list-style-type: none"> • Harness or connectors (EVAP control system pressure sensor circuit is open or shorted.) [CKP sensor (POS) circuit is shorted.] (APP sensor 2 circuit is shorted.) (Refrigerant pressure sensor circuit is shorted.) (Brake booster pressure sensor circuit is shorted) • EVAP control system pressure sensor • Crankshaft position sensor (POS) • Accelerator pedal position sensor • Refrigerant pressure sensor • Brake booster pressure sensor • EVAP canister vent control valve • EVAP canister • Rubber hose from EVAP canister vent control valve to vehicle frame

DTC CONFIRMATION PROCEDURE

1. PRECONDITIONING

If DTC Confirmation Procedure has been previously conducted, always perform the following procedure before conducting the next test.

1. Turn ignition switch OFF and wait at least 10 seconds.
2. Turn ignition switch ON.
3. Turn ignition switch OFF and wait at least 10 seconds.

TESTING CONDITION:

Always perform test at a temperature of 5°C (41°F) or more.

>> GO TO 2.

2. PERFORM DTC CONFIRMATION PROCEDURE

With CONSULT-III

1. Start engine and warm it up to normal operating temperature.
2. Turn ignition switch OFF and wait at least 10 seconds.
3. Turn ignition switch ON.
4. Turn ignition switch OFF and wait at least 10 seconds.
5. Turn ignition switch ON.
6. Select "DATA MONITOR" mode with CONSULT-III.

P0453 EVAP CONTROL SYSTEM PRESSURE SENSOR

[VQ37VHR]

< DTC/CIRCUIT DIAGNOSIS >

7. Make sure that "FUEL T/TMP SE" is more than 0°C (32°F).
8. Start engine and wait at least 20 seconds.
9. Check 1st trip DTC.

With GST

1. Start engine and warm it up to normal operating temperature.
2. Set voltmeter probes to ECM harness connector terminals as per the following.

ECM		
Connector	+	-
	Terminal	Terminal
M107	106 (Fuel tank temperature sensor signal)	128 (ECM ground)

3. Make sure that the voltage is less than 4.2 V.
4. Turn ignition switch OFF and wait at least 10 seconds.
5. Turn ignition switch ON.
6. Turn ignition switch OFF and wait at least 10 seconds.
7. Start engine and wait at least 20 seconds.
8. Check 1st trip DTC.

Is 1st trip DTC detected?

- YES >> Go to [EC-318, "Diagnosis Procedure"](#).
NO >> INSPECTION END

Diagnosis Procedure

INFOID:000000005151859

1.CHECK GROUND CONNECTION

1. Turn ignition switch OFF.
2. Check ground connection M95. Refer to Ground Inspection in [GI-39, "Circuit Inspection"](#).

Is the inspection result normal?

- YES >> GO TO 2.
NO >> Repair or replace ground connection.

2.CHECK CONNECTOR

1. Disconnect EVAP control system pressure sensor harness connector.
2. Check sensor harness connector for water.

Water should not exist.

Is the inspection result normal?

- YES >> GO TO 3.
NO >> Repair or replace harness connector.

3.CHECK EVAP CONTROL SYSTEM PRESSURE SENSOR POWER SUPPLY CIRCUIT

1. Turn ignition switch ON.
2. Check the voltage between EVAP control system pressure sensor harness connector and ground.

EVAP control system pressure sensor		Ground	Voltage (V)
Connector	Terminal		
B30	3	Ground	Approx. 5

Is the inspection result normal?

- YES >> GO TO 10.
NO >> GO TO 4.

4.CHECK EVAP CONTROL SYSTEM PRESSURE SENSOR POWER SUPPLY CIRCUIT-II

1. Turn ignition switch OFF.
2. Disconnect ECM harness connector.

P0453 EVAP CONTROL SYSTEM PRESSURE SENSOR

[VQ37VHR]

< DTC/CIRCUIT DIAGNOSIS >

3. Check the continuity between EVAP control system pressure sensor harness connector and ECM harness connector.

EVAP control system pressure sensor		ECM		Continuity
Connector	Terminal	Connector	Terminal	
B30	3	M107	107	Existed

Is the inspection result normal?

- YES >> GO TO 6.
NO >> GO TO 5.

5. DETECT MALFUNCTIONING PART

Check the following.

- Harness connectors M7, B1
- Harness for open between ECM and EVAP control system pressure sensor

>> Repair open circuit.

6. CHECK SENSOR POWER SUPPLY CIRCUIT

Check harness for short to power and short to ground, between the following terminals.

ECM		Sensor		
Connector	Terminal	Name	Connector	Terminal
F101	45	Brake booster pressure sensor	E48	1
	46	CKP sensor (POS)	F2	1
M107	103	APP sensor	E112	6
	107	EVAP control system pressure sensor	B30	3
	111	Refrigerant pressure sensor	E77	3

Is the inspection result normal?

- YES >> GO TO 7.
NO >> Repair short to ground or short to power in harness or connectors.

7. CHECK COMPONENTS

Check the following.

- Crankshaft position sensor (POS) (Refer to [EC-272, "Component Inspection"](#).)
- Brake booster pressure sensor (Refer to [EC-357, "Component Inspection"](#).)
- Refrigerant pressure sensor (Refer to [EC-516, "Diagnosis Procedure"](#).)

Is the inspection result normal?

- YES >> GO TO 8.
NO >> Replace malfunctioning component.

8. CHECK APP SENSOR

Refer to [EC-465, "Component Inspection"](#).

Is the inspection result normal?

- YES >> GO TO 20.
NO >> GO TO 9.

9. REPLACE ACCELERATOR PEDAL ASSEMBLY

1. Replace accelerator pedal assembly
2. Go to [EC-465, "Special Repair Requirement"](#).

>> INSPECTION END

10. CHECK EVAP CONTROL SYSTEM PRESSURE SENSOR GROUND CIRCUIT FOR OPEN AND SHORT

P0453 EVAP CONTROL SYSTEM PRESSURE SENSOR

[VQ37VHR]

< DTC/CIRCUIT DIAGNOSIS >

1. Turn ignition switch OFF.
2. Disconnect ECM harness connector.
3. Check the continuity between EVAP control system pressure sensor harness connector and ECM harness connector.

EVAP control system pressure sensor		ECM		Continuity
Connector	Terminal	Connector	Terminal	
B30	1	M107	112	Existed

4. Also check harness for short to ground and short to power.

Is the inspection result normal?

- YES >> GO TO 12.
NO >> GO TO 11.

11.DETECT MALFUNCTIONING PART

Check the following.

- Harness connectors B1, M7
- Harness for open or short between EVAP control system pressure sensor and ECM

>> Repair open circuit, short to ground or short to power in harness or connectors.

12.CHECK EVAP CONTROL SYSTEM PRESSURE SENSOR INPUT SIGNAL CIRCUIT FOR OPEN AND SHORT

1. Check the continuity between EVAP control system pressure sensor harness connector and ECM harness connector.

EVAP control system pressure sensor		ECM		Continuity
Connector	Terminal	Connector	Terminal	
B30	2	M107	102	Existed

2. Also check harness for short to ground and short to power.

Is the inspection result normal?

- YES >> GO TO 14.
NO >> GO TO 13.

13.DETECT MALFUNCTIONING PART

Check the following.

- Harness connectors B1, M7
- Harness for open or short between EVAP control system pressure sensor and ECM

>> Repair open circuit, short to ground or short to power in harness or connectors.

14.CHECK RUBBER TUBE

1. Disconnect rubber tube connected to EVAP canister vent control valve.
2. Check the rubber tube for clogging.

Is the inspection result normal?

- YES >> GO TO 15.
NO >> Clean the rubber tube using an air blower, repair or replace rubber tube.

15.CHECK EVAP CANISTER VENT CONTROL VALVE

Refer to [EC-303, "Component Inspection"](#).

Is the inspection result normal?

- YES >> GO TO 16.
NO >> Replace EVAP canister vent control valve.

16.CHECK EVAP CONTROL SYSTEM PRESSURE SENSOR

Refer to [EC-321, "Component Inspection"](#).

P0453 EVAP CONTROL SYSTEM PRESSURE SENSOR

[VQ37VHR]

< DTC/CIRCUIT DIAGNOSIS >

Is the inspection result normal?

- YES >> GO TO 17.
- NO >> Replace EVAP control system pressure sensor.

17. CHECK IF EVAP CANISTER IS SATURATED WITH WATER

1. Remove EVAP canister with EVAP canister vent control valve and EVAP control system pressure sensor attached.
2. Check if water will drain from the EVAP canister (1).

2 : EVAP canister vent control valve

Does water drain from EVAP canister?

- YES >> GO TO 18.
- NO >> GO TO 20.

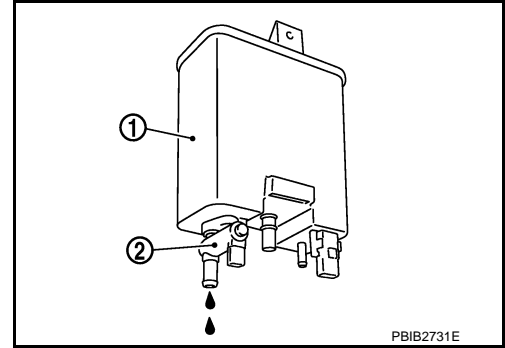

18. CHECK EVAP CANISTER

Weigh the EVAP canister with the EVAP canister vent control valve and EVAP control system pressure sensor attached.

The weight should be less than 2.2 kg (4.9 lb).

Is the inspection result normal?

- YES >> GO TO 20.
- NO >> GO TO 19.

19. DETECT MALFUNCTIONING PART

Check the following.

- EVAP canister for damage
- EVAP hose between EVAP canister and vehicle frame for clogging or poor connection

>> Repair hose or replace EVAP canister.

20. CHECK INTERMITTENT INCIDENT

Refer to [GI-36. "Intermittent Incident"](#).

>> INSPECTION END

Component Inspection

INFOID:000000005151860

1. CHECK EVAP CONTROL SYSTEM PRESSURE SENSOR

1. Turn ignition switch OFF.
2. Remove EVAP control system pressure sensor with its harness connector.
Always replace O-ring with a new one.
3. Install a vacuum pump to EVAP control system pressure sensor.
4. Turn ignition switch ON and check output voltage between ECM harness connector terminals under the following conditions.

ECM			Condition [Applied vacuum kPa (kg/cm ² , psi)]	Voltage (V)
Connector	+	-		
	Terminal	Terminal		
M107	102	112	Not applied	1.8 - 4.8
			-26.7 (-0.272, -3.87)	2.1 to 2.5 lower than above value

CAUTION:

- Always calibrate the vacuum pump gauge when using it.

P0453 EVAP CONTROL SYSTEM PRESSURE SENSOR

< DTC/CIRCUIT DIAGNOSIS >

[VQ37VHR]

- Do not apply below -93.3 kPa (-0.952 kg/cm², -13.53 psi) or pressure over 101.3 kPa (1.033 kg/cm², 14.69 psi).

Is the inspection result normal?

YES >> INSPECTION END

NO >> Replace EVAP control system pressure sensor.

P0455 EVAP CONTROL SYSTEM

< DTC/CIRCUIT DIAGNOSIS >

[VQ37VHR]

P0455 EVAP CONTROL SYSTEM

DTC Logic

INFOID:000000005151861

DTC DETECTION LOGIC

This diagnosis detects a very large leak (fuel filler cap fell off etc.) in EVAP system between the fuel tank and EVAP canister purge volume control solenoid valve.

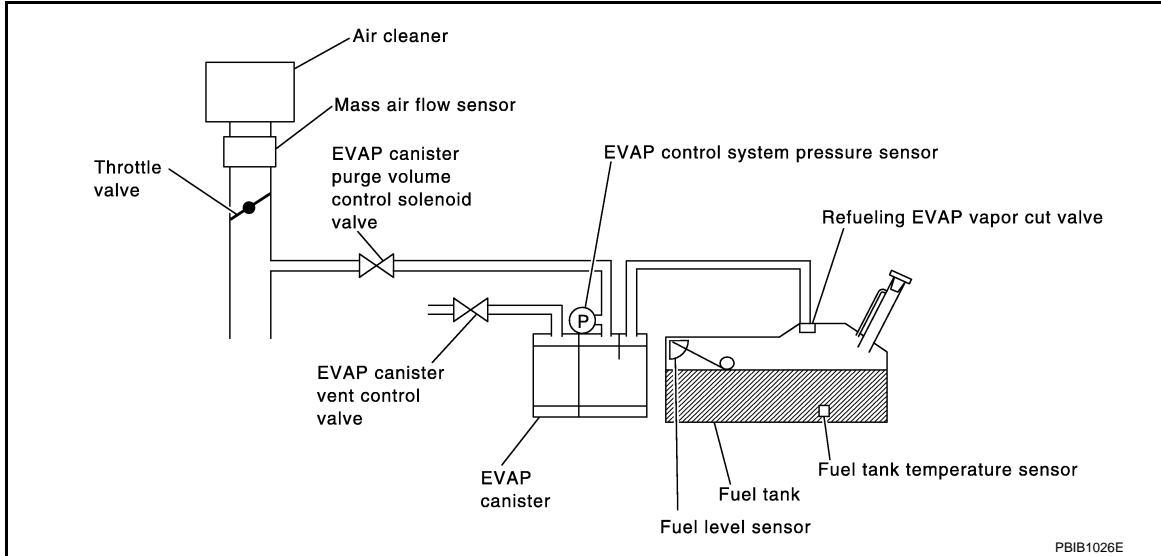

DTC No.	Trouble diagnosis name	DTC detecting condition	Possible cause
P0455	EVAP control system gross leak detected	EVAP control system has a very large leak such as fuel filler cap fell off, EVAP control system does not operate properly.	<ul style="list-style-type: none"> Fuel filler cap remains open or fails to close. Incorrect fuel tank vacuum relief valve Incorrect fuel filler cap used Foreign matter caught in fuel filler cap. Leak is in line between intake manifold and EVAP canister purge volume control solenoid valve. Foreign matter caught in EVAP canister vent control valve. EVAP canister or fuel tank leaks EVAP purge line (pipe and rubber tube) leaks EVAP purge line rubber tube bent. Loose or disconnected rubber tube EVAP canister vent control valve and the circuit EVAP canister purge volume control solenoid valve and the circuit Fuel tank temperature sensor O-ring of EVAP canister vent control valve is missing or damaged. EVAP control system pressure sensor Refueling EVAP vapor cut valve ORVR system leaks

CAUTION:

- Use only a genuine NISSAN fuel filler cap as a replacement. If an incorrect fuel filler cap is used, the MIL may illuminate.
- If the fuel filler cap is not tightened properly, the MIL may illuminate.
- Use only a genuine NISSAN rubber tube as a replacement.

DTC CONFIRMATION PROCEDURE

1. PRECONDITIONING

CAUTION:

P0455 EVAP CONTROL SYSTEM

[VQ37VHR]

< DTC/CIRCUIT DIAGNOSIS >

Never remove fuel filler cap during the DTC Confirmation Procedure.

If DTC Confirmation Procedure has been previously conducted, always perform the following procedure before conducting the next test.

1. Turn ignition switch OFF and wait at least 10 seconds.
2. Turn ignition switch ON.
3. Turn ignition switch OFF and wait at least 10 seconds.

NOTE:

Make sure that EVAP hoses are connected to EVAP canister purge volume control solenoid valve properly.

TESTING CONDITION:

- Perform "DTC WORK SUPPORT" when the fuel level is between 1/4 and 3/4 full, and vehicle is placed on flat level surface.
- Open engine hood before conducting the following procedures.

Do you have CONSULT-III?

- YES >> GO TO 2.
NO >> GO TO 4.

2.PERFORM DTC CONFIRMATION PROCEDURE

 **With CONSULT-III**

1. Tighten fuel filler cap securely until ratcheting sound is heard.
2. Turn ignition switch ON.
3. Turn ignition switch OFF and wait at least 10 seconds.
4. Turn ignition switch ON and select "DATA MONITOR" mode with CONSULT-III.
5. Make sure that the following conditions are met.

COOLAN TEMP/S: 0 - 70°C (32 - 158°F)

INT/A TEMP SE: 0 - 60°C (32 - 140°F)

6. Select "EVAP SML LEAK P0442/P1442" of "EVAPORATIVE SYSTEM" in "DTC WORK SUPPORT" mode with CONSULT-III.

Follow the instructions displayed on CONSULT-III screen.

NOTE:

If the engine speed cannot be maintained within the range displayed on the CONSULT-III screen, go to [EC-13, "BASIC INSPECTION : Special Repair Requirement"](#).

Which is displayed on CONSULT-III screen?

- OK >> INSPECTION END.
NG >> GO TO 3.

3.CHECK DTC

Check DTC.

Which DTC is detected?

- P0455 >> Go to [EC-327, "Component Inspection"](#).
P0442 >> Go to [EC-288, "Diagnosis Procedure"](#).

4.PERFORM DTC CONFIRMATION PROCEDURE

 **With GST**

NOTE:

Be sure to read the explanation of Driving Pattern in [EC-561, "How to Set SRT Code"](#) before driving vehicle.

1. Start engine.
2. Drive vehicle according to Driving Pattern.
3. Stop vehicle.
4. Turn ignition switch OFF, wait at least 10 seconds and then turn ON.
5. Check 1st trip DTC.

Is 1st trip DTC detected?

- YES-1 >> P0455: Go to [EC-327, "Component Inspection"](#).
YES-2 >> P0442: Go to [EC-288, "Diagnosis Procedure"](#).
YES-3 >> P0441: Go to [EC-284, "Diagnosis Procedure"](#).
NO >> INSPECTION END

P0455 EVAP CONTROL SYSTEM

[VQ37VHR]

< DTC/CIRCUIT DIAGNOSIS >

Diagnosis Procedure

INFOID:000000005151862

1. CHECK FUEL FILLER CAP DESIGN

1. Turn ignition switch OFF.
2. Check for genuine NISSAN fuel filler cap design.

Is the inspection result normal?

- YES >> GO TO 2.
NO >> Replace with genuine NISSAN fuel filler cap.

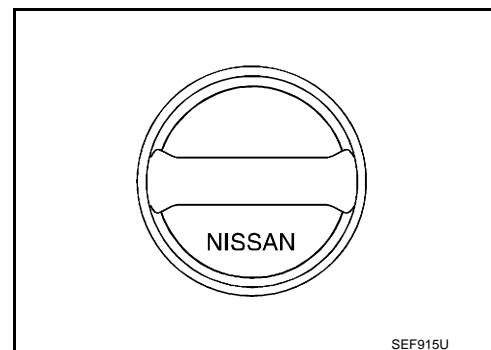

2. CHECK FUEL FILLER CAP INSTALLATION

Check that the cap is tightened properly by rotating the cap clockwise.

Is the inspection result normal?

- YES >> GO TO 3.
NO >> Open fuel filler cap, then clean cap and fuel filler neck threads using air blower. Retighten until ratcheting sound is heard.

3. CHECK FUEL FILLER CAP FUNCTION

Check for air releasing sound while opening the fuel filler cap.

Is the inspection result normal?

- YES >> GO TO 5.
NO >> GO TO 4.

4. CHECK FUEL TANK VACUUM RELIEF VALVE

Refer to [EC-512. "Component Inspection"](#).

Is the inspection result normal?

- YES >> GO TO 5.
NO >> Replace fuel filler cap with a genuine one.

5. CHECK EVAP PURGE LINE

Check EVAP purge line (pipe, rubber tube, fuel tank and EVAP canister) for cracks, improper connection or disconnection.

Refer to [EC-80. "System Diagram"](#).

Is the inspection result normal?

- YES >> GO TO 6.
NO >> Repair or reconnect the hose.

6. CLEAN EVAP PURGE LINE

Clean EVAP purge line (pipe and rubber tube) using air blower.

>> GO TO 7.

7. CHECK EVAP CANISTER VENT CONTROL VALVE

Check the following.

- EVAP canister vent control valve is installed properly.
Refer to [EC-610. "Removal and Installation"](#).
- EVAP canister vent control valve.
Refer to [EC-303. "Component Inspection"](#).

Is the inspection result normal?

- YES >> GO TO 8.
NO >> Repair or replace EVAP canister vent control valve and O-ring.

< DTC/CIRCUIT DIAGNOSIS >

8. CHECK FOR EVAP LEAK

Refer to [EC-608, "Inspection"](#).

Is there any leak in EVAP line?

- YES >> Repair or replace.
- NO-1 >> With CONSULT-III: GO TO 9.
- NO-2 >> Without CONSULT-III: GO TO 10.

9. CHECK EVAP CANISTER PURGE VOLUME CONTROL SOLENOID VALVE OPERATION

With CONSULT-III

1. Disconnect vacuum hose connected to EVAP canister purge volume control solenoid valve at EVAP service port.
2. Start engine and let it idle.
3. Select "PURG VOL CONT/V" in "ACTIVE TEST" mode.
4. Touch "Qu" on CONSULT-III screen to increase "PURG VOL C/V" opening to 100%.
5. Check vacuum hose for vacuum.

Vacuum should exist.

Is the inspection result normal?

- YES >> GO TO 12.
- NO >> GO TO 11.

10. CHECK EVAP CANISTER PURGE VOLUME CONTROL SOLENOID VALVE OPERATION

Without CONSULT-III

1. Start engine and warm it up to normal operating temperature.
2. Stop engine.
3. Disconnect vacuum hose connected to EVAP canister purge volume control solenoid valve at EVAP service port.
4. Start engine and let it idle for at least 80 seconds.
5. Check vacuum hose for vacuum when revving engine up to 2,000 rpm.

Vacuum should exist.

Is the inspection result normal?

- YES >> GO TO 13.
- NO >> GO TO 11.

11. CHECK VACUUM HOSE

Check vacuum hoses for clogging or disconnection. Refer to [EC-80, "System Diagram"](#).

Is the inspection result normal?

- YES-1 >> With CONSULT-III: GO TO 12.
- YES-2 >> Without CONSULT-III: GO TO 13.
- NO >> Repair or reconnect the hose.

12. CHECK EVAP CANISTER PURGE VOLUME CONTROL SOLENOID VALVE

With CONSULT-III

1. Start engine.
2. Perform "PURG VOL CONT/V" in "ACTIVE TEST" mode with CONSULT-III. Check that engine speed varies according to the valve opening.

Does engine speed vary according to the valve opening?

- YES >> GO TO 14.
- NO >> GO TO 13.

13. CHECK EVAP CANISTER PURGE VOLUME CONTROL SOLENOID VALVE

Refer to [EC-296, "Component Inspection"](#).

Is the inspection result normal?

- YES >> GO TO 14.
- NO >> Replace EVAP canister purge volume control solenoid valve.

P0455 EVAP CONTROL SYSTEM

[VQ37VHR]

< DTC/CIRCUIT DIAGNOSIS >

14. CHECK FUEL TANK TEMPERATURE SENSOR

Refer to [EC-246, "Component Inspection"](#).

Is the inspection result normal?

YES >> GO TO 15.

NO >> Replace fuel level sensor unit.

15. CHECK EVAP CONTROL SYSTEM PRESSURE SENSOR

Refer to [EC-311, "Component Inspection"](#).

Is the inspection result normal?

YES >> GO TO 16.

NO >> Replace EVAP control system pressure sensor.

16. CHECK EVAP/ORVR LINE

Check EVAP/ORVR line between EVAP canister and fuel tank for clogging, kinks, looseness and improper connection. For location, refer to [EC-509, "Description"](#).

Is the inspection result normal?

YES >> GO TO 17.

NO >> Repair or replace hoses and tubes.

17. CHECK RECIRCULATION LINE

Check recirculation line between filler neck tube and fuel tank for clogging, kinks, cracks, looseness and improper connection.

Is the inspection result normal?

YES >> GO TO 18.

NO >> Repair or replace hose, tube or filler neck tube.

18. CHECK REFUELING EVAP VAPOR CUT VALVE

Refer to [EC-512, "Component Inspection"](#).

Is the inspection result normal?

YES >> GO TO 19.

NO >> Replace refueling EVAP vapor cut valve with fuel tank.

19. CHECK INTERMITTENT INCIDENT

Refer to [GI-36, "Intermittent Incident"](#).

>> INSPECTION END

Component Inspection

INFOID:000000005151863

1. CHECK FUEL TANK VACUUM RELIEF VALVE

1. Turn ignition switch OFF.
2. Remove fuel filler cap.
3. Wipe clean valve housing.

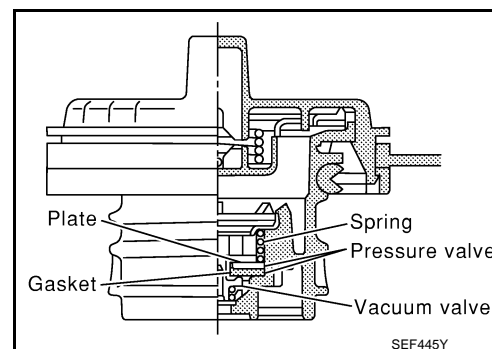

P0455 EVAP CONTROL SYSTEM

[VQ37VHR]

< DTC/CIRCUIT DIAGNOSIS >

4. Check valve opening pressure and vacuum.

Pressure: 15.3 - 20.0 kPa (0.156 - 0.204 kg/cm², 2.22 - 2.90 psi)

Vacuum: -6.0 to -3.3 kPa (-0.061 to -0.034 kg/cm², -0.87 to -0.48 psi)

Is the inspection result normal?

YES >> INSPECTION END

NO >> GO TO 2.

2. REPLACE FUEL FILLER CAP

Replace fuel filler cap.

CAUTION:

Use only a genuine fuel filler cap as a replacement. If an incorrect fuel filler cap is used, the MIL may illuminate.

>> INSPECTION END

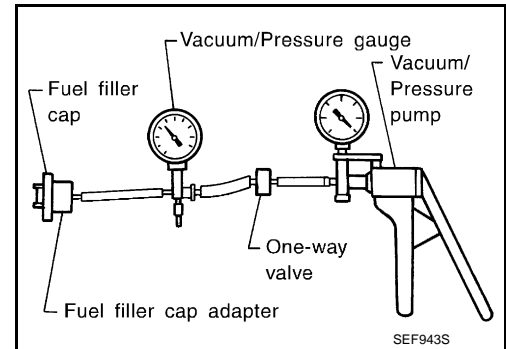

P0456 EVAP CONTROL SYSTEM

< DTC/CIRCUIT DIAGNOSIS >

[VQ37VHR]

P0456 EVAP CONTROL SYSTEM

DTC Logic

INFOID:000000005151864

DTC DETECTION LOGIC

NOTE:

If DTC P0456 is displayed with DTC P0442, first perform the trouble diagnosis for DTC P0456.

This diagnosis detects very small leaks in the EVAP line between fuel tank and EVAP canister purge volume control solenoid valve, using the intake manifold vacuum in the same way as conventional EVAP small leak diagnosis.

If ECM judges a leak which corresponds to a very small leak, the very small leak P0456 will be detected.

If ECM judges a leak equivalent to a small leak, EVAP small leak P0442 will be detected.

If ECM judges that there are no leaks, the diagnosis will be OK.

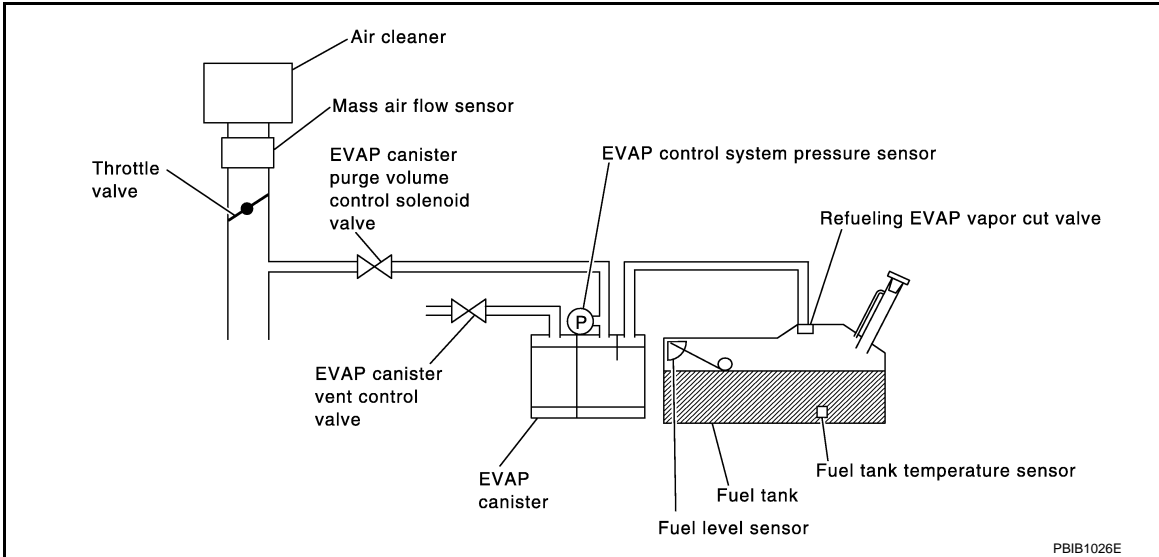

DTC No.	Trouble diagnosis name	DTC detecting condition	Possible cause
P0456	Evaporative emission control system very small leak (negative pressure check)	<ul style="list-style-type: none"> • EVAP system has a very small leak. • EVAP system does not operate properly. 	<ul style="list-style-type: none"> • Incorrect fuel tank vacuum relief valve • Incorrect fuel filler cap used • Fuel filler cap remains open or fails to close. • Foreign matter caught in fuel filler cap. • Leak is in line between intake manifold and EVAP canister purge volume control solenoid valve. • Foreign matter caught in EVAP canister vent control valve. • EVAP canister or fuel tank leaks • EVAP purge line (pipe and rubber tube) leaks • EVAP purge line rubber tube bent • Loose or disconnected rubber tube • EVAP canister vent control valve and the circuit • EVAP canister purge volume control solenoid valve and the circuit • Fuel tank temperature sensor • O-ring of EVAP canister vent control valve is missing or damaged • EVAP canister is saturated with water • EVAP control system pressure sensor • Refueling EVAP vapor cut valve • ORVR system leaks • Fuel level sensor and the circuit • Foreign matter caught in EVAP canister purge volume control solenoid valve

CAUTION:

- Use only a genuine NISSAN fuel filler cap as a replacement. If an incorrect fuel filler cap is used, the MIL may illuminate.

P0456 EVAP CONTROL SYSTEM

[VQ37VHR]

< DTC/CIRCUIT DIAGNOSIS >

- If the fuel filler cap is not tightened properly, the MIL may illuminate.
- Use only a genuine NISSAN rubber tube as a replacement.

DTC CONFIRMATION PROCEDURE

1. INSPECTION START

Do you have CONSULT-III?

Do you have CONSULT-III?

YES >> GO TO 2.

NO >> GO TO 4.

2. PRECONDITIONING

If DTC Confirmation Procedure has been previously conducted, always perform the following procedure before conducting the next test.

1. Turn ignition switch OFF and wait at least 10 seconds.
2. Turn ignition switch ON.
3. Turn ignition switch OFF and wait at least 10 seconds.

NOTE:

After repair, make sure that the hoses and clips are installed properly.

TESTING CONDITION:

- Open engine hood before conducting the following procedure.
- If any of following conditions are met just before the DTC confirmation procedure, leave the vehicle for more than 1 hour.
 - Fuel filler cap is removed.
 - Fuel is refilled or drained.
 - EVAP component part/parts is/are removed.
- Before performing the following procedure, confirm that battery voltage is more than 11 V at idle.
- Make sure that EVAP hoses are connected to EVAP canister purge volume control solenoid valve properly.

>> GO TO 3.

3. PERFORM DTC CONFIRMATION PROCEDURE

With CONSULT-III

1. Turn ignition switch ON and select "DATA MONITOR" mode with CONSULT-III.
2. Make sure that the following conditions are met.

FUEL LEVEL SE: 0.25 - 1.4 V

COOLAN TEMP/S: 0 - 32°C (32 - 90°F)

FUEL T/TMP SE: 0 - 35°C (32 - 95°F)

INT A/TEMP SE: More than 0°C (32°F)

If NG, turn ignition switch OFF and leave the vehicle in a cool place (soak the vehicle), or refill/drain fuel until the output voltage condition of the "FUEL LEVEL SE" meets within the range above and leave the vehicle for more than 1 hour. Then start from step 1.

3. Turn ignition switch OFF and wait at least 10 seconds.
4. Turn ignition switch ON.
5. Select "EVAP V/S LEAK P0456/P1456" of "EVAPORATIVE SYSTEM" in "DTC WORK SUPPORT" mode with CONSULT-III.

Follow the instructions displayed on CONSULT-III.

NOTE:

If the engine speed cannot be maintained within the range displayed on CONSULT-III screen, go to [EC-13. "BASIC INSPECTION : Special Repair Requirement"](#).

Which is displayed on CONSULT-III screen?

OK >> INSPECTION END

NG >> Go to [EC-331. "Diagnosis Procedure"](#).

4. PERFORM COMPONENT FUNCTION CHECK

Perform component function check. Refer to [EC-331. "Component Function Check"](#).

NOTE:

Use component function check to check the overall function of the EVAP very small leak function. During this check, a 1st trip DTC might not be confirmed.

P0456 EVAP CONTROL SYSTEM

[VQ37VHR]

< DTC/CIRCUIT DIAGNOSIS >

Is the inspection result normal?

- YES >> INSPECTION END
- NO >> Go to [EC-331, "Diagnosis Procedure"](#).

Component Function Check

INFOID:000000005151865

1. PERFORM COMPONENT FUNCTION CHECK

 With GST

CAUTION:

- Never use compressed air, doing so may damage the EVAP system.
- Never start engine.

• Never exceed 4.12 kPa (0.042 kg/cm², 0.6 psi).

1. Attach the EVAP service port adapter securely to the EVAP service port.
2. Set the pressure pump and a hose.
3. Also set a vacuum gauge via 3-way connector and a hose.
4. Turn ignition switch ON.
5. Connect GST and select Service \$08.
6. Using Service \$08 control the EVAP canister vent control valve (close).
7. Apply pressure and make sure the following conditions are satisfied.

Pressure to be applied: 2.7 kPa (0.028 kg/cm², 0.39 psi)

Time to be waited after the pressure drawn in to the EVAP system and the pressure to be dropped: 60 seconds and the pressure should not be dropped more than 0.4 kPa (0.004 kg/cm², 0.06 psi).

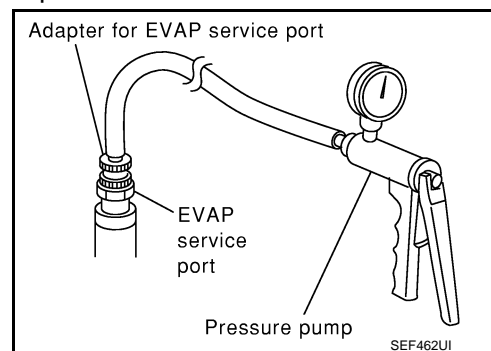

Is the inspection result normal?

- YES >> GO TO 2.
- NO >> Go to [EC-331, "Diagnosis Procedure"](#).

2. RELEASE PRESSURE

1. Disconnect GST.
2. Start engine and warm it up to normal operating temperature.
3. Turn ignition switch OFF and wait at least 10 seconds.
4. Turn ignition switch ON.
5. Turn ignition switch OFF and wait at least 10 seconds.
6. Restart engine and let it idle for 90 seconds.
7. Keep engine speed at 2,000 rpm for 30 seconds.
8. Turn ignition switch OFF.

NOTE:

For more information, refer to GST Instruction Manual.

>> INSPECTION END

Diagnosis Procedure

INFOID:000000005151865

1. CHECK FUEL FILLER CAP DESIGN

1. Turn ignition switch OFF.

P0456 EVAP CONTROL SYSTEM

[VQ37VHR]

< DTC/CIRCUIT DIAGNOSIS >

2. Check for genuine NISSAN fuel filler cap design.

Is the inspection result normal?

YES >> GO TO 2.

NO >> Replace with genuine NISSAN fuel filler cap.

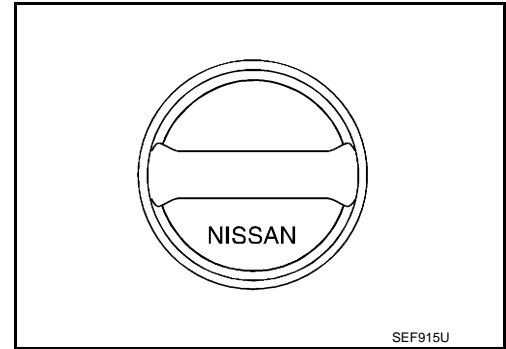

2. CHECK FUEL FILLER CAP INSTALLATION

Check that the cap is tightened properly by rotating the cap clockwise.

Is the inspection result normal?

YES >> GO TO 3.

NO >> Open fuel filler cap, then clean cap and fuel filler neck threads using air blower. Retighten until ratcheting sound is heard.

3. CHECK FUEL FILLER CAP FUNCTION

Check for air releasing sound while opening the fuel filler cap.

Is the inspection result normal?

YES >> GO TO 5.

NO >> GO TO 4.

4. CHECK FUEL TANK VACUUM RELIEF VALVE

Refer to [EC-512. "Component Inspection"](#).

Is the inspection result normal?

YES >> GO TO 5.

NO >> Replace fuel filler cap with a genuine one.

5. CHECK FOR EVAP LEAK

Refer to [EC-608. "Inspection"](#).

Is there any leak in EVAP line?

YES >> Repair or replace.

NO >> GO TO 6.

6. CHECK EVAP CANISTER VENT CONTROL VALVE

Check the following.

- EVAP canister vent control valve is installed properly.
Refer to [EC-610. "Removal and Installation"](#).
- EVAP canister vent control valve.
Refer to [EC-303. "Component Inspection"](#).

Is the inspection result normal?

YES >> GO TO 7.

NO >> Repair or replace EVAP canister vent control valve and O-ring.

7. CHECK IF EVAP CANISTER IS SATURATED WITH WATER

P0456 EVAP CONTROL SYSTEM

[VQ37VHR]

< DTC/CIRCUIT DIAGNOSIS >

1. Remove EVAP canister with EVAP canister vent control valve (2) and EVAP control system pressure sensor attached.
2. Check if water will drain from EVAP canister (1).

Does water drain from the EVAP canister?

- YES >> GO TO 8.
NO-1 >> With CONSULT-III: GO TO 10.
NO-2 >> Without CONSULT-III: GO TO 11.

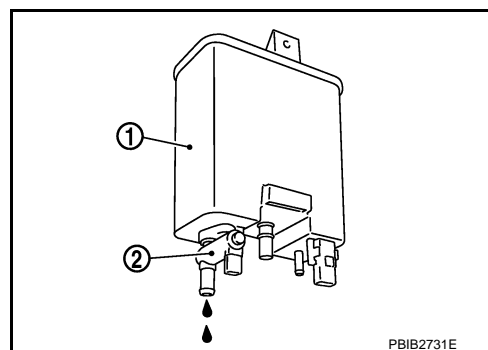

8. CHECK EVAP CANISTER

Weigh the EVAP canister with the EVAP canister vent control valve and EVAP control system pressure sensor attached.

The weight should be less than 2.2 kg (4.9 lb).

Is the inspection result normal?

- YES-1 >> With CONSULT-III: GO TO 10.
YES-2 >> Without CONSULT-III: GO TO 11.
NO >> GO TO 9.

9. DETECT MALFUNCTIONING PART

Check the following.

- EVAP canister for damage
- EVAP hose between EVAP canister and vehicle frame for clogging or poor connection

>> Repair hose or replace EVAP canister.

10. CHECK EVAP CANISTER PURGE VOLUME CONTROL SOLENOID VALVE OPERATION

With CONSULT-III

1. Disconnect vacuum hose connected to EVAP service port and EVAP canister purge volume control solenoid valve from EVAP service port.
2. Start engine and let it idle.
3. Select "PURG VOL CONT/V" in "ACTIVE TEST" mode.
4. Touch "Qu" on CONSULT-III screen to increase "PURG VOL C/V" opening to 100%.
5. Check vacuum hose for vacuum.

Vacuum should exist.

Is the inspection result normal?

- YES >> GO TO 13.
NO >> GO TO 12.

11. CHECK EVAP CANISTER PURGE VOLUME CONTROL SOLENOID VALVE OPERATION

Without CONSULT-III

1. Start engine and warm it up to normal operating temperature.
2. Stop engine.
3. Disconnect vacuum hose connected to EVAP service port and EVAP canister purge volume control solenoid valve from EVAP service port.
4. Start engine and let it idle for at least 80 seconds.
5. Check vacuum hose for vacuum when revving engine up to 2,000 rpm.

Vacuum should exist.

Is the inspection result normal?

- YES >> GO TO 14.
NO >> GO TO 12.

12. CHECK VACUUM HOSE

Check vacuum hoses for clogging or disconnection. Refer to [EC-80, "System Diagram"](#).

P0456 EVAP CONTROL SYSTEM

[VQ37VHR]

< DTC/CIRCUIT DIAGNOSIS >

Is the inspection result normal?

- YES >> GO TO 13.
- NO >> Repair or reconnect the hose.

13.CHECK EVAP CANISTER PURGE VOLUME CONTROL SOLENOID VALVE

Refer to [EC-296, "Component Inspection"](#).

Is the inspection result normal?

- YES >> GO TO 14.
- NO >> Replace EVAP canister purge volume control solenoid valve.

14.CHECK FUEL TANK TEMPERATURE SENSOR

Refer to [EC-246, "Component Inspection"](#).

Is the inspection result normal?

- YES >> GO TO 15.
- NO >> Replace fuel level sensor unit.

15.CHECK EVAP CONTROL SYSTEM PRESSURE SENSOR

Refer to [EC-311, "Component Inspection"](#).

Is the inspection result normal?

- YES >> GO TO 16.
- NO >> Replace EVAP control system pressure sensor.

16.CHECK EVAP PURGE LINE

Check EVAP purge line (pipe, rubber tube, fuel tank and EVAP canister) for cracks or improper connection.

Refer to [EC-80, "System Diagram"](#).

Is the inspection result normal?

- YES >> GO TO 17.
- NO >> Repair or reconnect the hose.

17.CLEAN EVAP PURGE LINE

Clean EVAP purge line (pipe and rubber tube) using air blower.

>> GO TO 18.

18.CHECK EVAP/ORVR LINE

Check EVAP/ORVR line between EVAP canister and fuel tank for clogging, kinks, looseness and improper connection. For location, refer to [EC-509, "Description"](#).

Is the inspection result normal?

- YES >> GO TO 19.
- NO >> Repair or replace hoses and tubes.

19.CHECK RECIRCULATION LINE

Check recirculation line between filler neck tube and fuel tank for clogging, kinks, cracks, looseness and improper connection.

Is the inspection result normal?

- YES >> GO TO 20.
- NO >> Repair or replace hose, tube or filler neck tube.

20.CHECK REFUELING EVAP VAPOR CUT VALVE

Refer to [EC-512, "Component Inspection"](#).

Is the inspection result normal?

- YES >> GO TO 21.
- NO >> Replace refueling EVAP vapor cut valve with fuel tank.

21.CHECK FUEL LEVEL SENSOR

Refer to [MWI-54, "Component Inspection"](#).

Is the inspection result normal?

P0456 EVAP CONTROL SYSTEM

[VQ37VHR]

< DTC/CIRCUIT DIAGNOSIS >

- YES >> GO TO 22.
- NO >> Replace fuel level sensor unit.

22.CHECK INTERMITTENT INCIDENT

Refer to [GI-36. "Intermittent Incident"](#).

>> INSPECTION END

Component Inspection

INFOID:000000005151867

1.CHECK FUEL TANK VACUUM RELIEF VALVE

1. Turn ignition switch OFF.
2. Remove fuel filler cap.
3. Wipe clean valve housing.

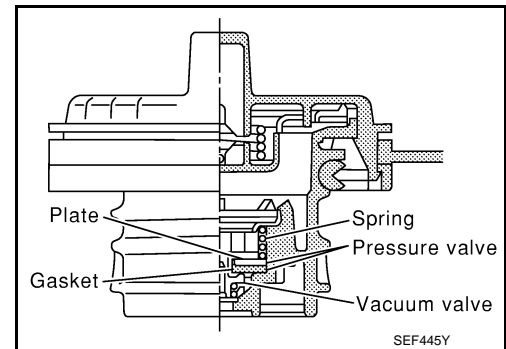

4. Check valve opening pressure and vacuum.

Pressure: 15.3 - 20.0 kPa (0.156 - 0.204 kg/cm², 2.22 - 2.90 psi)

Vacuum: -6.0 to -3.3 kPa (-0.061 to -0.034 kg/cm², -0.87 to -0.48 psi)

Is the inspection result normal?

- YES >> INSPECTION END
- NO >> GO TO 2.

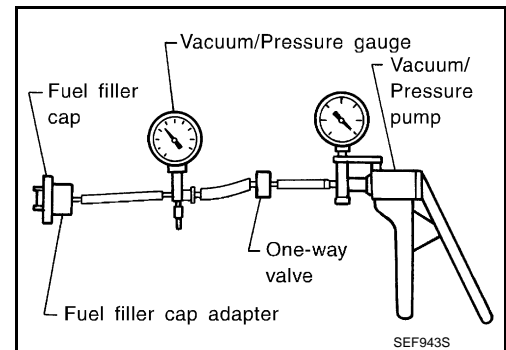

2.REPLACE FUEL FILLER CAP

Replace fuel filler cap.

CAUTION:

Use only a genuine fuel filler cap as a replacement. If an incorrect fuel filler cap is used, the MIL may illuminate.

>> INSPECTION END

P0460 FUEL LEVEL SENSOR

< DTC/CIRCUIT DIAGNOSIS >

[VQ37VHR]

P0460 FUEL LEVEL SENSOR

Description

INFOID:000000005151868

The fuel level sensor is mounted in the fuel level sensor unit.

The sensor detects a fuel level in the fuel tank and transmits a signal to the “unified meter and A/C amp.”. The “unified meter and A/C amp.” sends the fuel level sensor signal to the ECM via the CAN communication line. It consists of two parts, one is mechanical float and the other is variable resistor. Fuel level sensor output voltage changes depending on the movement of the fuel mechanical float.

DTC Logic

INFOID:000000005151869

DTC DETECTION LOGIC

NOTE:

- If DTC P0460 is displayed with DTC UXXXX, first perform the trouble diagnosis for DTC UXXXX.
- If DTC P0460 is displayed with DTC P0607, first perform the trouble diagnosis for DTC P0607. Refer to [EC-363, "DTC Logic"](#).

When the vehicle is parked, the fuel level in the fuel tank is naturally stable. It means that output signal of the fuel level sensor does not change. If ECM senses sloshing signal from the sensor, fuel level sensor malfunction is detected.

DTC No.	Trouble diagnosis name	DTC detecting condition	Possible cause
P0460	Fuel level sensor circuit noise	Even though the vehicle is parked, a signal being varied is sent from the fuel level sensor to ECM.	<ul style="list-style-type: none">• Harness or connectors (The CAN communication line is open or shorted)• Harness or connectors (The sensor circuit is open or shorted)• Unified meter and A/C amp.• Fuel level sensor

DTC CONFIRMATION PROCEDURE

1. PRECONDITIONING

If DTC Confirmation Procedure has been previously conducted, always perform the following procedure before conducting the next test.

1. Turn ignition switch OFF and wait at least 10 seconds.
2. Turn ignition switch ON.
3. Turn ignition switch OFF and wait at least 10 seconds.

>> GO TO 2.

2. PERFORM DTC CONFIRMATION PROCEDURE

1. Start engine and wait maximum of 2 consecutive minutes.
2. Check 1st trip DTC.

Is 1st trip DTC detected?

- YES >> Go to [EC-336, "Diagnosis Procedure"](#).
NO >> INSPECTION END

Diagnosis Procedure

INFOID:000000005151870

1. CHECK DTC WITH “UNIFIED METER AND A/C AMP.”

Refer to [MWI-37, "CONSULT-III Function \(METER/M&A\)"](#).

Is the inspection result normal?

- YES >> GO TO 2.
NO >> Go to [MWI-53, "Component Function Check"](#).

2. CHECK INTERMITTENT INCIDENT

Refer to [GI-36, "Intermittent Incident"](#).

P0460 FUEL LEVEL SENSOR

< DTC/CIRCUIT DIAGNOSIS >

[VQ37VHR]

>> INSPECTION END

A

EC

C

D

E

F

G

H

I

J

K

L

M

N

O

P

P0461 FUEL LEVEL SENSOR

< DTC/CIRCUIT DIAGNOSIS >

[VQ37VHR]

P0461 FUEL LEVEL SENSOR

Description

INFOID:000000005151871

The fuel level sensor is mounted in the fuel level sensor unit.

The sensor detects a fuel level in the fuel tank and transmits a signal to the “unified meter and A/C amp.”. The “unified meter and A/C amp.” sends the fuel level sensor signal to the ECM via the CAN communication line. It consists of two parts, one is mechanical float and the other is variable resistor. Fuel level sensor output voltage changes depending on the movement of the fuel mechanical float.

DTC Logic

INFOID:000000005151872

DTC DETECTION LOGIC

NOTE:

- If DTC P0461 is displayed with DTC UXXXX, first perform the trouble diagnosis for DTC UXXXX.
- If DTC P0461 is displayed with DTC P0607, first perform the trouble diagnosis for DTC P0607. Refer to [EC-363, "DTC Logic"](#).

Driving long distances naturally affect fuel gauge level.

This diagnosis detects the fuel gauge malfunction of the gauge not moving even after a long distance has been driven.

DTC No.	Trouble diagnosis name	DTC detecting condition	Possible cause
P0461	Fuel level sensor circuit range/performance	The output signal of the fuel level sensor does not change within the specified range even though the vehicle has been driven a long distance.	<ul style="list-style-type: none">• Harness or connectors (The CAN communication line is open or shorted)• Harness or connectors (The sensor circuit is open or shorted)• Unified meter and A/C amp.• Fuel level sensor

DTC CONFIRMATION PROCEDURE

1. PERFORM COMPONENT FUNCTION CHECK

Perform component function check. Refer to [EC-338, "Component Function Check"](#).

Use component function check to check the overall function of the fuel level sensor. During this check, a 1st trip DTC might not be confirmed.

Is the inspection result normal?

YES >> INSPECTION END

NO >> Go to [EC-339, "Diagnosis Procedure"](#).

Component Function Check

INFOID:000000005151873

1. PRECONDITIONING

WARNING:

When performing the following procedure, always observe the handling of the fuel. Refer to [FL-5, "Removal and Installation"](#).

TESTING CONDITION:

Before starting component function check, preparation of draining fuel and refilling fuel is required.

Do you have CONSULT-III?

YES >> GO TO 2.

NO >> GO TO 3.

2. PERFORM COMPONENT FUNCTION CHECK

With CONSULT-III

NOTE:

Start from step 10, if it is possible to confirm that the fuel cannot be drained by 30 ℓ (7-7/8 US gal, 6-5/8 Imp gal) in advance.

1. Prepare a fuel container and a spare hose.

P0461 FUEL LEVEL SENSOR

[VQ37VHR]

< DTC/CIRCUIT DIAGNOSIS >

2. Release fuel pressure from fuel line, refer to [EC-607, "Inspection"](#).
3. Remove the fuel feed hose on the fuel level sensor unit.
4. Connect a spare fuel hose where the fuel feed hose was removed.
5. Turn ignition switch OFF and wait at least 10 seconds then turn ON.
6. Select "FUEL LEVEL SE" in "DATA MONITOR" mode with CONSULT-III.
7. Check "FUEL LEVEL SE" output voltage and note it.
8. Select "FUEL PUMP RELAY" in "ACTIVE TEST" mode with CONSULT-III.
9. Touch "ON" and drain fuel approximately 30 ℓ (7-7/8 US gal, 6-5/8 Imp gal) and stop it.
10. Check "FUEL LEVEL SE" output voltage and note it.
11. Fill fuel into the fuel tank for 30 ℓ (7-7/8 US gal, 6-5/8 Imp gal).
12. Check "FUEL LEVEL SE" output voltage and note it.
13. Confirm whether the voltage changes more than 0.03V during step 7 to 10 and 10 to 12.

Is the inspection result normal?

- YES >> INSPECTION END
NO >> Go to [EC-339, "Diagnosis Procedure"](#).

3.PERFORM COMPONENT FUNCTION CHECK

Without CONSULT-III

NOTE:

Start from step 8, if it is possible to confirm that the fuel cannot be drained by 30 ℓ (7-7/8 US gal, 6-5/8 Imp gal) in advance.

1. Prepare a fuel container and a spare hose.
2. Release fuel pressure from fuel line. Refer to [EC-607, "Inspection"](#).
3. Remove the fuel feed hose on the fuel level sensor unit.
4. Connect a spare fuel hose where the fuel feed hose was removed.
5. Turn ignition switch ON.
6. Drain fuel by 30 ℓ (7-7/8 US gal, 6-5/8 Imp gal) from the fuel tank using proper equipment.
7. Confirm that the fuel gauge indication varies.
8. Fill fuel into the fuel tank for 30 ℓ (7-7/8 US gal, 6-5/8 Imp gal).
9. Confirm that the fuel gauge indication varies.

Is the inspection result normal?

- YES >> INSPECTION END
NO >> Go to [EC-339, "Diagnosis Procedure"](#).

Diagnosis Procedure

INFOID:000000005151874

1.CHECK DTC WITH "UNIFIED METER AND A/C AMP."

Refer to [MWI-37, "CONSULT-III Function \(METER/M&A\)"](#).

Is the inspection result normal?

- YES >> GO TO 2.
NO >> Go to [MWI-53, "Component Function Check"](#).

2.CHECK INTERMITTENT INCIDENT

Refer to [GI-36, "Intermittent Incident"](#).

>> INSPECTION END

P0462, P0463 FUEL LEVEL SENSOR

< DTC/CIRCUIT DIAGNOSIS >

[VQ37VHR]

P0462, P0463 FUEL LEVEL SENSOR

Description

INFOID:000000005151875

The fuel level sensor is mounted in the fuel level sensor unit. The sensor detects a fuel level in the fuel tank and transmits a signal to the “unified meter and A/C amp.”. The “unified meter and A/C amp.” sends the fuel level sensor signal to the ECM via the CAN communication line. It consists of two parts, one is mechanical float and the other is variable resistor. Fuel level sensor output voltage changes depending on the movement of the fuel mechanical float.

DTC Logic

INFOID:000000005151876

DTC DETECTION LOGIC

NOTE:

- If DTC P0462 or P0463 is displayed with DTC UXXXX, first perform the trouble diagnosis for DTC UXXXX.
- If DTC P0462 or P0463 is displayed with DTC P0607, first perform the trouble diagnosis for DTC P0607. Refer to [EC-363, "DTC Logic"](#).

DTC No.	Trouble diagnosis name	DTC detecting condition	Possible cause
P0462	Fuel level sensor circuit low input	An excessively low voltage from the sensor is sent to ECM.	<ul style="list-style-type: none">• Harness or connectors (The CAN communication line is open or shorted)
P0463	Fuel level sensor circuit high input	An excessively high voltage from the sensor is sent to ECM.	<ul style="list-style-type: none">• Harness or connectors (The sensor circuit is open or shorted)• Unified meter and A/C amp.• Fuel level sensor

DTC CONFIRMATION PROCEDURE

1. PRECONDITIONING

If DTC Confirmation Procedure has been previously conducted, always perform the following procedure before conducting the next test.

1. Turn ignition switch OFF and wait at least 10 seconds.
2. Turn ignition switch ON.
3. Turn ignition switch OFF and wait at least 10 seconds.

TESTING CONDITION:

Before performing the following procedure, confirm that battery voltage is more than 11 V at ignition switch ON.

>> GO TO 2.

2. PERFORM DTC CONFIRMATION PROCEDURE

1. Turn ignition switch ON and wait at least 5 seconds.
2. Check 1st trip DTC.

Is 1st trip DTC detected?

- YES >> Go to [EC-340, "Diagnosis Procedure"](#).
NO >> INSPECTION END

Diagnosis Procedure

INFOID:000000005151877

1. CHECK DTC WITH “UNIFIED METER AND A/C AMP.”

Refer to [MWI-37, "CONSULT-III Function \(METER/M&A\)"](#).

Is the inspection result normal?

- YES >> GO TO 2.
NO >> Go to [MWI-53, "Component Function Check"](#).

2. CHECK INTERMITTENT INCIDENT

Refer to [GI-36, "Intermittent Incident"](#).

P0462, P0463 FUEL LEVEL SENSOR

< DTC/CIRCUIT DIAGNOSIS >

[VQ37VHR]

>> INSPECTION END

A

EC

C

D

E

F

G

H

I

J

K

L

M

N

O

P

P0500 VSS

Description

INFOID:000000005151878

The vehicle speed signal is sent to the “unified meter and A/C amp.” from the “ABS actuator and electric unit (control unit)” via the CAN communication line. The “unified meter and A/C amp.” then sends a signal to the ECM via the CAN communication line.

DTC Logic

INFOID:000000005151879

DTC DETECTION LOGIC

NOTE:

- If DTC P0500 is displayed with DTC UXXXX, first perform the trouble diagnosis for DTC UXXXX.
- If DTC P0500 is displayed with DTC P0607, first perform the trouble diagnosis for DTC P0607. Refer to [EC-363, "DTC Logic"](#).

DTC No.	Trouble diagnosis name	DTC detecting condition	Possible cause
P0500	Vehicle speed sensor	The vehicle speed signal sent to ECM is almost 0 km/h (0 MPH) even when vehicle is being driven.	<ul style="list-style-type: none"> • Harness or connectors (The CAN communication line is open or shorted) • Harness or connectors (The vehicle speed signal circuit is open or shorted) • Wheel sensor • Unified meter and A/C amp. • ABS actuator and electric unit (control unit)

DTC CONFIRMATION PROCEDURE

1.INSPECTION START

Do you have CONSULT-III?

Do you have CONSULT-III?

- YES >> GO TO 2.
- NO >> GO TO 5.

2.PRECONDITIONING

If DTC Confirmation Procedure has been previously conducted, always perform the following procedure before conducting the next test.

1. Turn ignition switch OFF and wait at least 10 seconds.
2. Turn ignition switch ON.
3. Turn ignition switch OFF and wait at least 10 seconds.

>> GO TO 3.

3.CHECK VEHICLE SPEED SIGNAL

NOTE:

This procedure may be conducted with the drive wheels lifted in the shop or by driving the vehicle. If a road test is expected to be easier, it is unnecessary to lift the vehicle.

 With CONSULT-III

1. Start engine (VDC switch OFF).
2. Read “VHCL SPEED SE” in “DATA MONITOR” mode with CONSULT-III. The vehicle speed on CONSULT-III should exceed 10 km/h (6 MPH) when rotating wheels with suitable gear position.

Is the inspection result normal?

- YES >> GO TO 4.
- NO >> Go to [EC-343, "Diagnosis Procedure"](#).

4.PERFORM DTC CONFIRMATION PROCEDURE

1. Select “DATA MONITOR” mode with CONSULT-III.
2. Warm engine up to normal operating temperature.

< DTC/CIRCUIT DIAGNOSIS >

3. Maintain the following conditions for at least 50 consecutive seconds.

CAUTION:

Always drive vehicle at a safe speed.

ENG SPEED	1,800 - 6,000 rpm
COOLAN TEMP/S	More than 70°C (158°F)
B/FUEL SCHDL	5.0 - 31.8 msec
Selector lever	Except P or N position (A/T) Except Neutral position (M/T)
PW/ST SIGNAL	OFF

4. Check 1st trip DTC.

Is 1st trip DTC detected?

YES >> Go to [EC-343, "Diagnosis Procedure"](#).

NO >> INSPECTION END

5.PERFORM COMPONENT FUNCTION CHECK

Perform component function check. Refer to [EC-343, "Component Function Check"](#).

Use component function check to check the overall function of the vehicle speed signal circuit. During this check, a 1st trip DTC might not be confirmed.

Is the inspection result normal?

YES >> INSPECTION END

NO >> Go to [EC-343, "Diagnosis Procedure"](#).

Component Function Check

INFOID:000000005151880

1.PERFORM COMPONENT FUNCTION CHECK

 **With GST**

1. Lift up drive wheels.

2. Start engine.

3. Read vehicle speed signal in Service \$01 with GST.

The vehicle speed signal on GST should be able to exceed 10 km/h (6 MPH) when rotating wheels with suitable gear position.

Is the inspection result normal?

YES >> INSPECTION END

NO >> Go to [EC-343, "Diagnosis Procedure"](#).

Diagnosis Procedure

INFOID:000000005151881

1.CHECK DTC WITH "ABS ACTUATOR AND ELECTRIC UNIT (CONTROL UNIT)"

Refer to [BRC-27, "CONSULT-III Function"](#).

Is the inspection result normal?

YES >> GO TO 2.

NO >> Repair or replace.

2.CHECK DTC WITH "UNIFIED METER AND A/C AMP."

Refer to [MWI-37, "CONSULT-III Function \(METER/M&A\)"](#).

>> INSPECTION END

P0506 ISC SYSTEM

Description

INFOID:000000005151882

The ECM controls the engine idle speed to a specified level through the fine adjustment of the air, which is let into the intake manifold, by operating the electric throttle control actuator. The operating of the throttle valve is varied to allow for optimum control of the engine idling speed. The crankshaft position sensor (POS) detects the actual engine speed and sends a signal to the ECM.

The ECM controls the electric throttle control actuator so that the engine speed coincides with the target value memorized in the ECM. The target engine speed is the lowest speed at which the engine can operate steadily. The optimum value stored in the ECM is determined by taking into consideration various engine conditions, such as during warming up, deceleration and engine load (air conditioner, power steering and cooling fan operation, etc.).

DTC Logic

INFOID:000000005151883

DTC DETECTION LOGIC

NOTE:

If DTC P0506 is displayed with other DTC, first perform the trouble diagnosis for the other DTC.

DTC No.	Trouble diagnosis name	DTC detecting condition	Possible cause
P0506	Idle speed control system RPM lower than expected	The idle speed is less than the target idle speed by 100 rpm or more.	<ul style="list-style-type: none"> • Electric throttle control actuator • Intake air leak

DTC CONFIRMATION PROCEDURE

1. PRECONDITIONING

If DTC Confirmation Procedure has been previously conducted, always perform the following procedure before conducting the next test.

1. Turn ignition switch OFF and wait at least 10 seconds.
2. Turn ignition switch ON.
3. Turn ignition switch OFF and wait at least 10 seconds.

If the idle speed is out of the specified value, perform [EC-19, "IDLE AIR VOLUME LEARNING : Special Repair Requirement"](#), before conducting DTC Confirmation Procedure.

TESTING CONDITION:

- Before performing the following procedure, confirm that battery voltage is more than 11 V at idle.
- Always perform the test at a temperature above -10°C(14°F).

>> GO TO 2.

2. PERFORM DTC CONFIRMATION PROCEDURE

1. Start engine and warm it up to normal operating temperature.
2. Turn ignition switch OFF and wait at least 10 seconds.
3. Turn ignition switch ON.
4. Turn ignition switch OFF and wait at least 10 seconds.
5. Restart engine and run it for at least 1 minute at idle speed.
6. Check 1st trip DTC.

Is 1st trip DTC detected?

- YES >> Go to [EC-344, "Diagnosis Procedure"](#).
- NO >> INSPECTION END

Diagnosis Procedure

INFOID:000000005151884

1. CHECK INTAKE AIR LEAK

1. Start engine and let it idle.
2. Listen for an intake air leak after the mass air flow sensor.

Is intake air leak detected?

P0506 ISC SYSTEM

[VQ37VHR]

< DTC/CIRCUIT DIAGNOSIS >

YES >> Discover air leak location and repair.

NO >> GO TO 2.

2.REPLACE ECM

1. Stop engine.
2. Replace ECM.
3. Go to [EC-16, "ADDITIONAL SERVICE WHEN REPLACING CONTROL UNIT \(ECM\) : Special Repair Requirement"](#).

>> INSPECTION END

A

EC

C

D

E

F

G

H

I

J

K

L

M

N

O

P

P0507 ISC SYSTEM

Description

INFOID:000000005151885

The ECM controls the engine idle speed to a specified level through the fine adjustment of the air, which is let into the intake manifold, by operating the electric throttle control actuator. The operating of the throttle valve is varied to allow for optimum control of the engine idling speed. The crankshaft position sensor (POS) detects the actual engine speed and sends a signal to the ECM.

The ECM controls the electric throttle control actuator so that the engine speed coincides with the target value memorized in the ECM. The target engine speed is the lowest speed at which the engine can operate steadily. The optimum value stored in the ECM is determined by taking into consideration various engine conditions, such as during warming up, deceleration and engine load (air conditioner, power steering and cooling fan operation, etc.).

DTC Logic

INFOID:000000005151886

DTC DETECTION LOGIC

NOTE:

If DTC P0507 is displayed with other DTC, first perform the trouble diagnosis for the other DTC.

DTC No.	Trouble diagnosis name	DTC detecting condition	Possible cause
P0507	Idle speed control system RPM higher than expected	The idle speed is more than the target idle speed by 200 rpm or more.	<ul style="list-style-type: none"> • Electric throttle control actuator • Intake air leak • PCV system

DTC CONFIRMATION PROCEDURE

1. PRECONDITIONING

If DTC Confirmation Procedure has been previously conducted, always perform the following procedure before conducting the next test.

1. Turn ignition switch OFF and wait at least 10 seconds.
2. Turn ignition switch ON.
3. Turn ignition switch OFF and wait at least 10 seconds.

If the idle speed is out of the specified value, perform [EC-19, "IDLE AIR VOLUME LEARNING : Special Repair Requirement"](#), before conducting DTC Confirmation Procedure.

TESTING CONDITION:

- Before performing the following procedure, confirm that battery voltage is more than 11 V at idle.
- Always perform the test at a temperature above -10°C(14°F).

>> GO TO 2.

2. PERFORM DTC CONFIRMATION PROCEDURE

1. Start engine and warm it up to normal operating temperature.
2. Turn ignition switch OFF and wait at least 10 seconds.
3. Turn ignition switch ON.
4. Turn ignition switch OFF and wait at least 10 seconds.
5. Start engine and run it for at least 1 minute at idle speed.
6. Check 1st trip DTC.

Is 1st trip DTC detected?

- YES >> Go to [EC-346, "Diagnosis Procedure"](#).
- NO >> INSPECTION END

Diagnosis Procedure

INFOID:000000005151887

1. CHECK PCV HOSE CONNECTION

Confirm that PCV hose is connected correctly.

Is the inspection result normal?

- YES >> GO TO 2.

P0507 ISC SYSTEM

[VQ37VHR]

< DTC/CIRCUIT DIAGNOSIS >

NO >> Repair or replace.

2.CHECK INTAKE AIR LEAK

1. Start engine and let it idle.
2. Listen for an intake air leak after the mass air flow sensor.

Is intake air leak detected?

YES >> Discover air leak location and repair.

NO >> GO TO 3.

3.REPLACE ECM

1. Stop engine.
2. Replace ECM.
3. Go to [EC-16. "ADDITIONAL SERVICE WHEN REPLACING CONTROL UNIT \(ECM\) : Special Repair Requirement"](#).

>> INSPECTION END

A

EC

C

D

E

F

G

H

I

J

K

L

M

N

O

P

P0524 ENGINE OIL PRESSURE

< DTC/CIRCUIT DIAGNOSIS >

[VQ37VHR]

P0524 ENGINE OIL PRESSURE

DTC Logic

INFOID:000000005151888

DTC DETECTION LOGIC

NOTE:

If DTC P0524 is displayed with DTC P0075 or P0081, first perform the trouble diagnosis for DTC P0075, P0081. Refer to [EC-162, "DTC Logic"](#)

DTC No.	Trouble diagnosis name	Detecting condition	Possible cause
P0524	Engine oil pressure too low	Engine oil pressure is low because there is a gap between angle of target and phase-control angle.	<ul style="list-style-type: none">• Engine oil pressure or level too low• Crankshaft position sensor (POS)• Camshaft position sensor (PHASE)• Intake valve control solenoid valve• Accumulation of debris to the signal pick-up portion of the camshaft• Timing chain installation• Foreign matter caught in the oil groove for intake valve timing control

DTC CONFIRMATION PROCEDURE

1. PRECONDITIONING-I

If DTC Confirmation Procedure has been previously conducted, always perform the following procedure before conducting the next test.

1. Turn ignition switch OFF and wait at least 10 seconds.
2. Turn ignition switch ON.
3. Turn ignition switch OFF and wait at least 10 seconds.

TESTING CONDITION:

Before performing the following procedure, confirm that battery voltage is between 10 V and 16 V at idle.

>> GO TO 2.

2. PRECONDITIONING-II

Check oil level and oil pressure. Refer to [LU-6, "Inspection"](#).

Is the inspection result normal?

YES >> GO TO 3.

NO >> Go to [LU-6, "Inspection"](#).

3. PERFORM DTC CONFIRMATION PROCEDURE

1. Select "DATA MONITOR" mode with CONSULT-III.
2. Maintain the following conditions for at least 20 consecutive seconds.

ENG SPEED	More than 1,700 rpm
COOLAN TEMP/S	More than 70°C (158°F)
Selector lever	1st or 2nd position
Driving location	Driving vehicle uphill (Increased engine load will help maintain the driving conditions required for this test.)

CAUTION:

Always drive at a safe speed.

3. Check 1st trip DTC.

Is 1st trip DTC detected?

YES >> Go to [EC-349, "Diagnosis Procedure"](#)

NO >> INSPECTION END

P0524 ENGINE OIL PRESSURE

[VQ37VHR]

< DTC/CIRCUIT DIAGNOSIS >

Diagnosis Procedure

INFOID:000000005151889

1. CHECK OIL PRESSURE WARNING LAMP

1. Start engine.
2. Check oil pressure warning lamp and confirm it is not illuminated.

Is oil pressure warning lamp illuminated?

- YES >> Go to [LU-6, "Inspection"](#).
NO >> GO TO 2.

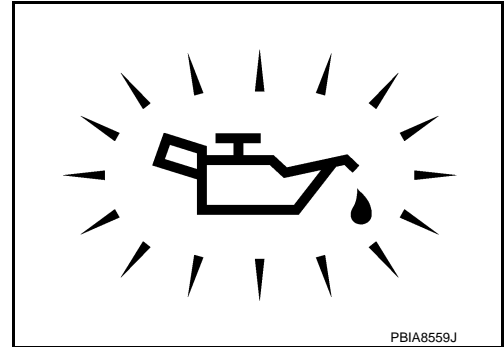

2. CHECK INTAKE VALVE TIMING CONTROL SOLENOID VALVE

Refer to [EC-154, "Component Inspection"](#).

Is the inspection result normal?

- YES >> GO TO 3.
NO >> Replace malfunctioning intake valve timing control solenoid valve.

3. CHECK CRANKSHAFT POSITION SENSOR (POS)

Refer to [EC-272, "Component Inspection"](#).

Is the inspection result normal?

- YES >> GO TO 4.
NO >> Replace crankshaft position sensor (POS).

4. CHECK CAMSHAFT POSITION SENSOR (PHASE)

Refer to [EC-275, "Component Inspection"](#).

Is the inspection result normal?

- YES >> GO TO 5.
NO >> Replace malfunctioning camshaft position sensor (PHASE).

5. CHECK CAMSHAFT (INTAKE)

Check the following.

- Accumulation of debris to the signal plate of camshaft front end
- Chipping signal plate of camshaft front end

Is the inspection result normal?

- YES >> GO TO 6.
NO >> Remove debris and clean the signal plate of camshaft front end or replace camshaft.

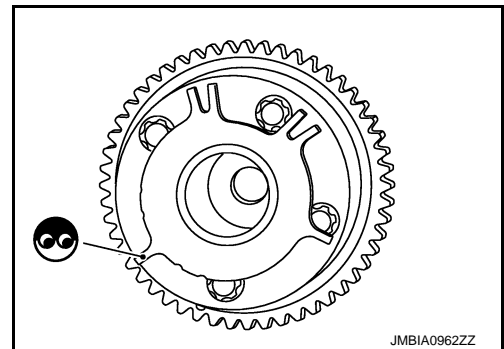

6. CHECK TIMING CHAIN INSTALLATION

Check service records for any recent repairs that may cause timing chain misaligned.

Are there any service records that may cause timing chain misaligned?

- YES >> Check timing chain installation. Refer to [EM-50, "Removal and Installation"](#).
NO >> GO TO 7.

7. CHECK LUBRICATION CIRCUIT

Perform "Inspection of Camshaft Sprocket (INT) Oil Groove". Refer to [EM-94, "Inspection"](#).

Is the inspection result normal?

P0524 ENGINE OIL PRESSURE

[VQ37VHR]

< DTC/CIRCUIT DIAGNOSIS >

- YES >> GO TO 8.
- NO >> Clean lubrication line.

8.CHECK INTERMITTENT INCIDENT

Refer to [GI-36. "Intermittent Incident"](#).

>> INSPECTION END

Component Inspection

INFOID:000000005151890

1.CHECK INTAKE VALVE TIMING CONTROL SOLENOID VALVE-I

1. Turn ignition switch OFF.
2. Disconnect intake valve timing control solenoid valve harness connector.
3. Check resistance between intake valve timing control solenoid valve terminals as per the following.

Terminals	Resistance (Ω)
1 and 2	7.0 - 7.7 [at 20°C (68°F)]
1 or 2 and ground	∞ (Continuity should not exist)

Is the inspection result normal?

- YES >> GO TO 2.
- NO >> Replace malfunctioning intake valve timing control solenoid valve.

2.CHECK INTAKE VALVE TIMING CONTROL SOLENOID VALVE-II

1. Remove intake valve timing control solenoid valve.
2. Provide 12 V DC between intake valve timing control solenoid valve terminals 1 and 2, and then interrupt it. Make sure that the plunger moves as shown in the figure.

CAUTION:

Never apply 12 V DC continuously for 5 seconds or more. Doing so may result in damage to the coil in intake valve timing control solenoid valve.

NOTE:

Always replace O-ring when intake valve timing control solenoid valve is removed.

Is the inspection result normal?

- YES >> INSPECTION END
- NO >> Replace malfunctioning intake valve timing control solenoid valve.

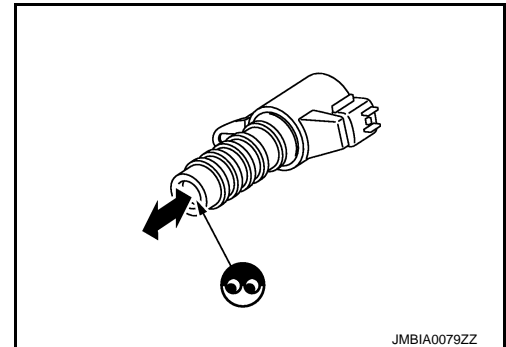

P0550 PSP SENSOR

< DTC/CIRCUIT DIAGNOSIS >

[VQ37VHR]

P0550 PSP SENSOR

Description

INFOID:000000005151891

Power steering pressure (PSP) sensor is installed to the power steering high-pressure tube and detects a power steering load.

This sensor is a potentiometer which transforms the power steering load into output voltage, and emits the voltage signal to the ECM. The ECM controls the electric throttle control actuator and adjusts the throttle valve opening angle to increase the engine speed and adjusts the idle speed for the increased load.

DTC Logic

INFOID:000000005151892

DTC DETECTION LOGIC

NOTE:

If DTC P0550 is displayed with DTC P0643, first perform the trouble diagnosis for DTC P0643. Refer to [EC-364, "DTC Logic"](#).

DTC No.	Trouble diagnosis name	DTC detecting condition	Possible cause
P0550	Power steering pressure sensor circuit	An excessively low or high voltage from the sensor is sent to ECM.	<ul style="list-style-type: none">• Harness or connectors (The sensor circuit is open or shorted)• Power steering pressure sensor

DTC CONFIRMATION PROCEDURE

1. PRECONDITIONING

If DTC Confirmation Procedure has been previously conducted, always perform the following procedure before conducting the next test.

1. Turn ignition switch OFF and wait at least 10 seconds.
2. Turn ignition switch ON.
3. Turn ignition switch OFF and wait at least 10 seconds.

>> GO TO 2.

2. PERFORM DTC CONFIRMATION PROCEDURE

1. Start engine and let it idle for at least 5 seconds.
2. Check 1st trip DTC.

Is 1st trip DTC detected?

- YES >> Go to [EC-351, "Diagnosis Procedure"](#).
NO >> INSPECTION END

Diagnosis Procedure

INFOID:000000005151893

1. CHECK GROUND CONNECTION

1. Turn ignition switch OFF.
2. Check ground connection M95. Refer to Ground Inspection in [GI-39, "Circuit Inspection"](#).

Is the inspection result normal?

- YES >> GO TO 2.
NO >> Repair or replace ground connection.

2. CHECK PSP SENSOR POWER SUPPLY CIRCUIT

1. Disconnect power steering pressure (PSP) sensor harness connector.
2. Turn ignition switch ON.
3. Check the voltage between PSP sensor harness connector and ground.

PSP sensor		Ground	Voltage (V)
Connector	Terminal		
F35	3	Ground	Approx. 5

P0550 PSP SENSOR

[VQ37VHR]

< DTC/CIRCUIT DIAGNOSIS >

Is the inspection result normal?

YES >> GO TO 3.

NO >> Repair open circuit, short to ground or short to power in harness or connectors.

3.CHECK PSP SENSOR GROUND CIRCUIT FOR OPEN AND SHORT

1. Turn ignition switch OFF.
2. Disconnect ECM harness connector.
3. Check the continuity between PSP sensor harness connector and ECM harness connector.

PSP sensor		ECM		Continuity
Connector	Terminal	Connector	Terminal	
F35	1	F102	96	Existed

4. Also check harness for short to ground and short to power.

Is the inspection result normal?

YES >> GO TO 4.

NO >> Repair open circuit, short to ground short to power in harness or connectors.

4.CHECK PSP SENSOR INPUT SIGNAL CIRCUIT FOR OPEN AND SHORT

1. Check the continuity between PSP sensor harness connector and ECM harness connector.

PSP sensor		ECM		Continuity
Connector	Terminal	Connector	Terminal	
F35	2	F102	87	Existed

2. Also check harness for short to ground and short to power.

Is the inspection result normal?

YES >> GO TO 5.

NO >> Repair open circuit, short to ground or short to power in harness or connectors.

5.CHECK PSP SENSOR

Refer to [EC-352, "Component Inspection"](#).

Is the inspection result normal?

YES >> GO TO 6.

NO >> Replace PSP sensor.

6.CHECK INTERMITTENT INCIDENT

Refer to [GI-36, "Intermittent Incident"](#).

>> INSPECTION END

Component Inspection

INFOID:000000005151894

1.CHECK POWER STEERING PRESSURE SENSOR

1. Turn ignition switch OFF.
2. Reconnect all harness connectors disconnected.
3. Start engine and let it idle.
4. Check the voltage between ECM harness connector terminals under the following conditions.

ECM			Condition	Voltage (V)	
Connector	+	-			
		Terminal	Terminal		
F102	87	96	Steering wheel	Being turned	0.5 - 4.5
				Not being turned	0.4 - 0.8

Is the inspection result normal?

P0550 PSP SENSOR

< DTC/CIRCUIT DIAGNOSIS >

[VQ37VHR]

YES >> INSPECTION END
NO >> Replace power steering pressure sensor.

A

EC

C

D

E

F

G

H

I

J

K

L

M

N

O

P

P0555 BRAKE BOOSTER PRESSURE SENSOR

< DTC/CIRCUIT DIAGNOSIS >

[VQ37VHR]

P0555 BRAKE BOOSTER PRESSURE SENSOR

Description

INFOID:000000005151895

Brake booster pressure sensor is connected to brake booster by a hose. It detects brake booster pressure and sends the voltage signal to the ECM. The sensor uses a silicon diaphragm which is sensitive to the change in pressure. As the pressure increases, the voltage rises.

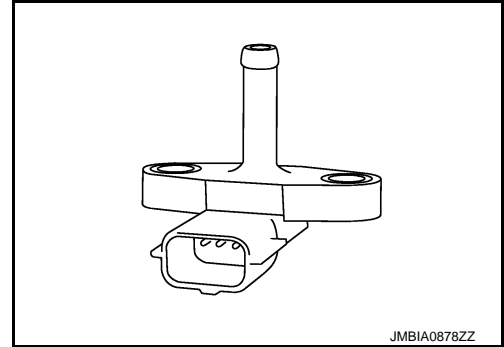

DTC Logic

INFOID:000000005151896

DTC DETECTION LOGIC

DTC No.	Trouble diagnosis name	DTC detecting condition	Possible cause
P0555	Brake booster pressure sensor circuit	<ul style="list-style-type: none">An excessively low voltage from the sensor is sent to ECM.An excessively high voltage from the sensor is sent to ECM.	<ul style="list-style-type: none">Harness or connectors (The sensor circuit is open or shorted.) [CKP sensor (POS) circuit is shorted.] (APP sensor 2 circuit is shorted) (EVAP control system pressure sensor circuit is shorted.) (Refrigerant pressure sensor circuit is shorted.)Brake booster pressure sensorCrankshaft position sensor (POS)Accelerator pedal position sensorEVAP control system pressure sensorRefrigerant pressure sensor

DTC CONFIRMATION PROCEDURE

1. PRECONDITIONING

If DTC Confirmation Procedure has been previously conducted, always perform the following procedure before conducting the next test.

- Turn ignition switch OFF and wait at least 10 seconds.
- Turn ignition switch ON.
- Turn ignition switch OFF and wait at least 10 seconds.

>> GO TO 2.

2. PERFORM DTC CONFIRMATION PROCEDURE

- Start engine and let it idle for 10 seconds.
- Check DTC.

Is DTC detected?

- YES >> Go to [EC-354, "Diagnosis Procedure"](#).
NO >> INSPECTION END

Diagnosis Procedure

INFOID:000000005151897

1. CHECK GROUND CONNECTION

- Turn ignition switch OFF.
- Check ground connection M95. Refer to Ground Inspection in [GI-39, "Circuit Inspection"](#).

Is the inspection result normal?

P0555 BRAKE BOOSTER PRESSURE SENSOR

[VQ37VHR]

< DTC/CIRCUIT DIAGNOSIS >

- YES >> GO TO 2.
NO >> Repair or replace ground connection.

2.CHECK BRAKE BOOSTER PRESSURE SENSOR POWER SUPPLY CIRCUIT

1. Disconnect brake booster pressure sensor harness connector.
2. Turn ignition switch ON.
3. Check the voltage between brake booster pressure sensor harness connector and ground.

Brake booster pressure sensor		Ground	Voltage (V)
Connector	Terminal		
E48	1	Ground	Approx. 5

Is the inspection result normal?

- YES >> GO TO 9.
NO >> GO TO 3.

3.CHECK BRAKE BOOSTER PRESSURE SENSOR POWER SUPPLY CIRCUIT-II

1. Turn ignition switch OFF.
2. Disconnect ECM harness connector.
3. Check the continuity between Brake booster pressure sensor harness connector and ECM harness connector.

Brake booster pressure sensor		ECM		Continuity
Connector	Terminal	Connector	Terminal	
E48	1	F101	45	Existed

Is the inspection result normal?

- YES >> GO TO 5.
NO >> GO TO 4.

4.DETECT MALFUNCTIONING PART

Check the following.

- Harness connectors F1, E3
- Harness for open between ECM and brake booster pressure sensor

>> Repair open circuit.

5.CHECK SENSOR POWER SUPPLY CIRCUIT

Check harness for short to power and short to ground, between the following terminals.

ECM		Sensor		
Connector	Terminal	Name	Connector	Terminal
F101	45	Brake booster pressure sensor	E48	1
	46	CKP sensor (POS)	F2	1
M107	103	APP sensor	E112	6
	107	EVAP control system pressure sensor	B30	3
		Refrigerant pressure sensor	E77	3

Is the inspection result normal?

- YES >> GO TO 6.
NO >> Repair short to ground or short to power in harness or connectors.

6.CHECK COMPONENTS

Check the following.

- Crankshaft position sensor (POS) (Refer to [EC-272, "Component Inspection".](#))
- EVAP control system pressure sensor (Refer to [EC-311, "Component Inspection".](#))

P0555 BRAKE BOOSTER PRESSURE SENSOR

[VQ37VHR]

< DTC/CIRCUIT DIAGNOSIS >

- Refrigerant pressure sensor (Refer to [EC-516, "Component Function Check"](#).)

Is the inspection result normal?

- YES >> GO TO 7.
NO >> Replace malfunctioning component.

7. CHECK APP SENSOR

Refer to [EC-465, "Component Inspection"](#).

Is the inspection result normal?

- YES >> GO TO 14.
NO >> GO TO 8.

8. REPLACE ACCELERATOR PEDAL ASSEMBLY

1. Replace accelerator pedal assembly
2. Go to [EC-465, "Special Repair Requirement"](#).

>> INSPECTION END

9. CHECK BRAKE BOOSTER PRESSURE SENSOR GROUND CIRCUIT FOR OPEN AND SHORT

1. Turn ignition switch OFF.
2. Disconnect ECM harness connector.
3. Check the continuity between brake booster pressure sensor harness connector and ECM harness connector.

Brake booster pressure sensor		ECM		Continuity
Connector	Terminal	Connector	Terminal	
E48	3	F101	36	Existed

4. Also check harness for short to ground and power.

Is the inspection result normal?

- YES >> GO TO 11.
NO >> GO TO 10.

10. DETECT MALFUNCTIONING PART

Check the following.

- Harness connectors F1, E3
- Harness for open or short between brake booster pressure sensor and ECM

>> Repair open circuit, short to ground or short to power in harness or connectors.

11. CHECK BRAKE BOOSTER PRESSURE SENSOR INPUT SIGNAL CIRCUIT FOR OPEN AND SHORT

1. Check the continuity between brake booster pressure sensor harness connector and ECM harness connector.

Brake booster pressure sensor		ECM		Continuity
Connector	Terminal	Connector	Terminal	
E48	2	F101	39	Existed

2. Also check harness for short to ground and power.

Is the inspection result normal?

- YES >> GO TO 13.
NO >> GO TO 12.

12. DETECT MALFUNCTIONING PART

Check the following.

- Harness connectors F1, E3
- Harness for open or short between brake booster pressure sensor and ECM

P0555 BRAKE BOOSTER PRESSURE SENSOR

< DTC/CIRCUIT DIAGNOSIS >

[VQ37VHR]

>> Repair open circuit, short to ground or short to power in harness or connectors.

13.CHECK BRAKE BOOSTER PRESSURE SENSOR

Refer to [EC-357, "Component Inspection"](#).

Is the inspection result normal?

YES >> GO TO 14.

NO >> Replace brake booster pressure sensor.

14.CHECK INTERMITTENT INCIDENT

Refer to [GI-36, "Intermittent Incident"](#).

>> INSPECTION END

Component Inspection

INFOID:000000005151898

1.CHECK BRAKE BOOSTER PRESSURE SENSOR-I

1. Turn ignition switch OFF.
2. Start engine and warm it up to normal operating temperature.
3. Turn ignition switch OFF, wait at least 5 seconds and then turn ON.
4. Check the voltage between ECM harness connector terminals as per the following.

Connector	ECM	
	+	-
	Terminal	Terminal
F101	39	36

NOTE:

- To avoid the influence of intake manifold vacuum, check the voltage 1 or more minutes past after engine is stopped.
- Because the sensor is absolute pressure sensor, output value may differ depends on atmospheric pressure and altitude.

5. Measure the atmospheric pressure.

NOTE:

As the atmospheric pressure described on the synoptic chart is the value at sea level, compensate the pressure with the following chart.

Altitude (m)	Compensated pressure (hPa)
0	0
200	-24
400	-47
600	-70
800	-92
1000	-114
1500	-168
2000	-218

6. Check the manifold absolute pressure sensor value corresponding to the atmospheric pressure.

P0555 BRAKE BOOSTER PRESSURE SENSOR

< DTC/CIRCUIT DIAGNOSIS >

[VQ37VHR]

Atmospheric pressure (hPa)	Voltage (V)
800	3.1 – 3.7
850	3.3 – 3.9
900	3.5 – 4.1
950	3.8 – 4.3
1000	4.0 – 4.6
1050	4.2 - 4.8

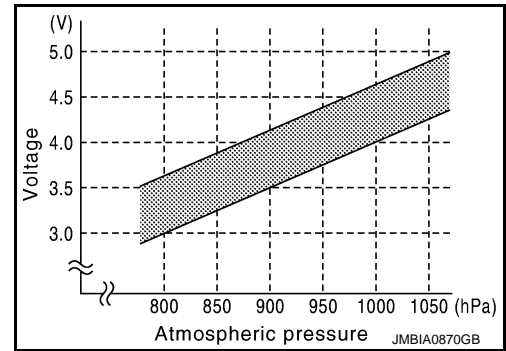

Is the inspection result normal?

YES >> GO TO 2.

NO >> Replace brake booster pressure sensor.

2. CHECK BRAKE BOOSTER PRESSURE SENSOR-II

1. Turn ignition switch OFF.
2. Remove brake booster pressure sensor with its harness connected.
3. Connect the hose of vacuum pump (A) to brake booster pressure sensor (1).
4. Turn ignition switch ON.

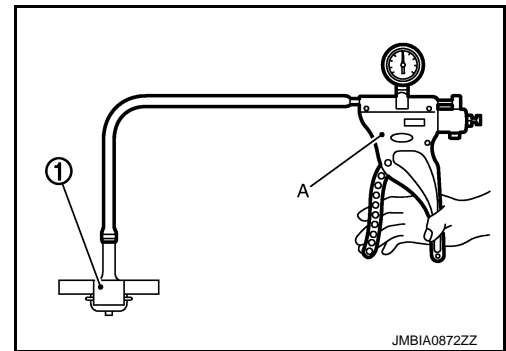

5. Check the voltage between ECM harness connector terminals as per the following.

ECM			
+		-	
Connector	Terminal	Connector	Terminal
F101	39	F101	36

6. Check that the difference of the voltage when engine is stopped and that when negative pressure is applied with vacuum pump is within the following limits.

Vacuum	Voltage difference (V)
-40kPa (-300mmHg)	1.5 – 2.0
-53.3kPa (-400mmHg)	2.0 – 2.6
-66.7kPa (-500mmHg)	2.6 – 3.2
-80kPa (-600mmHg)	3.2 – 3.8

Is the inspection result normal?

YES >> INSPECTION END

NO >> Replace brake booster pressure sensor.

P0603 ECM POWER SUPPLY

< DTC/CIRCUIT DIAGNOSIS >

[VQ37VHR]

P0603 ECM POWER SUPPLY

Description

INFOID:000000005151899

Battery voltage is supplied to the ECM even when the ignition switch is turned OFF for the ECM memory function of the DTC memory, the air-fuel ratio feedback compensation value memory, the idle air volume learning value memory, etc.

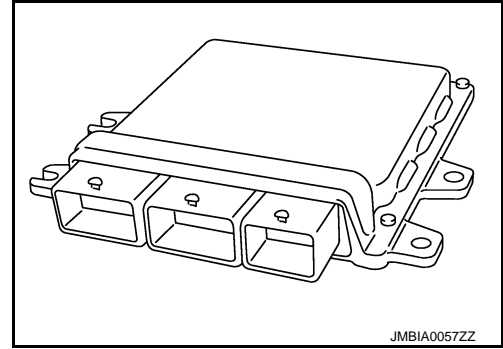

JMBIA0057ZZ

DTC Logic

INFOID:000000005151900

DTC DETECTION LOGIC

DTC No.	Trouble diagnosis name	DTC detecting condition	Possible cause
P0603	ECM power supply circuit	ECM back up RAM system does not function properly.	<ul style="list-style-type: none"> • Harness or connectors [ECM power supply (back up) circuit is open or shorted.] • ECM

DTC CONFIRMATION PROCEDURE

1. PRECONDITIONING

If DTC Confirmation Procedure has been previously conducted, always perform the following procedure before conducting the next test.

1. Turn ignition switch OFF and wait at least 10 seconds.
2. Turn ignition switch ON.
3. Turn ignition switch OFF and wait at least 10 seconds.

>> GO TO 2.

2. PERFORM DTC CONFIRMATION PROCEDURE

1. Turn ignition switch ON and wait at least 1 second.
2. Start engine and let it idle for 1 second.
3. Turn ignition switch OFF, wait at least 10 seconds, and then turn it ON.
4. Repeat steps 2 and 3 for four times.
5. Check 1st trip DTC.

Is 1st trip DTC detected?

- YES >> Go to [EC-359. "Diagnosis Procedure"](#).
- NO >> INSPECTION END

Diagnosis Procedure

INFOID:000000005151901

1. CHECK ECM POWER SUPPLY

1. Turn ignition switch OFF.
2. Disconnect ECM harness connector.
3. Check the voltage between ECM harness connector terminals as per the following.

P0603 ECM POWER SUPPLY

< DTC/CIRCUIT DIAGNOSIS >

[VQ37VHR]

ECM				Voltage
+		-		
Connector	Terminal	Connector	Terminal	
F102	93	M107	128	Battery voltage

Is the inspection result normal?

- YES >> GO TO 3.
- NO >> GO TO 2.

2. DETECT MALFUNCTIONING PART

Check the following.

- Harness connectors E3, F1
- 15 A fuse (No. 50)
- IPDM E/R harness connector E7
- Harness for open or short between ECM and battery

>> Repair or replace harness or connectors.

3. CHECK INTERMITTENT INCIDENT

Refer to [GI-36. "Intermittent Incident"](#).

Is the inspection result normal?

- YES >> GO TO 4.
- NO >> Repair or replace harness or connectors.

4. PERFORM DTC CONFIRMATION PROCEDURE

1. Turn ignition switch ON.
2. Erase DTC.
3. **Perform DTC Confirmation Procedure.**
See [EC-359. "DTC Logic"](#).

Is the 1st trip DTC P0603 displayed again?

- YES >> GO TO 5.
- NO >> INSPECTION END

5. REPLACE ECM

1. Replace ECM.
2. Go to [EC-16. "ADDITIONAL SERVICE WHEN REPLACING CONTROL UNIT \(ECM\) : Special Repair Requirement"](#).

>> INSPECTION END

P0605 ECM

Description

INFOID:000000005151902

The ECM consists of a microcomputer and connectors for signal input and output and for power supply. The ECM controls the engine.

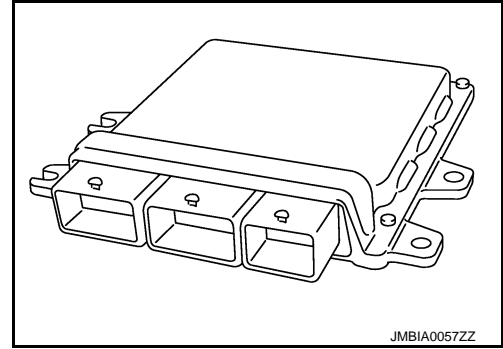

INFOID:000000005151903

DTC Logic

DTC DETECTION LOGIC

DTC No.	Trouble diagnosis name	DTC detecting condition		Possible cause
P0605	Engine control module	A)	ECM calculation function is malfunctioning.	• ECM
		B)	ECM EEP-ROM system is malfunctioning.	
		C)	ECM self shut-off function is malfunctioning.	

DTC CONFIRMATION PROCEDURE

1. PRECONDITIONING

If DTC Confirmation Procedure has been previously conducted, always perform the following procedure before conducting the next test.

1. Turn ignition switch OFF and wait at least 10 seconds.
2. Turn ignition switch ON.
3. Turn ignition switch OFF and wait at least 10 seconds.

>> GO TO 2.

2. PERFORM DTC CONFIRMATION PROCEDURE FOR MALFUNCTION A

1. Turn ignition switch ON.
2. Check 1st trip DTC.

Is 1st trip DTC detected?

YES >> Go to [EC-362, "Diagnosis Procedure"](#).

NO >> GO TO 3.

3. PERFORM DTC CONFIRMATION PROCEDURE FOR MALFUNCTION B

1. Turn ignition switch ON and wait at least 1 second.
2. Turn ignition switch OFF, wait at least 10 seconds, and then turn it ON.
3. Check 1st trip DTC.

Is 1st trip DTC detected?

YES >> Go to [EC-362, "Diagnosis Procedure"](#).

NO >> GO TO 4.

4. PERFORM DTC CONFIRMATION PROCEDURE FOR MALFUNCTION C

1. Turn ignition switch ON and wait at least 1 second.
2. Turn ignition switch OFF, wait at least 10 seconds, and then turn it ON.
3. Repeat step 2 for 32 times.
4. Check 1st trip DTC.

Is 1st trip DTC detected?

P0605 ECM

[VQ37VHR]

< DTC/CIRCUIT DIAGNOSIS >

- YES >> Go to [EC-362, "Diagnosis Procedure"](#).
NO >> INSPECTION END

Diagnosis Procedure

INFOID:000000005151904

1.INSPECTION START

1. Turn ignition switch ON.
2. Erase DTC.
3. **Perform DTC Confirmation Procedure.**
See [EC-361, "DTC Logic"](#).

Is the 1st trip DTC P0605 displayed again?

- YES >> GO TO 2.
NO >> INSPECTION END

2.REPLACE ECM

1. Replace ECM.
2. Go to [EC-16, "ADDITIONAL SERVICE WHEN REPLACING CONTROL UNIT \(ECM\) : Special Repair Requirement"](#).

>> INSPECTION END

P0607 ECM

Description

INFOID:000000005151905

CAN (Controller Area Network) is a serial communication line for real time application. It is an on-vehicle multiplex communication line with high data communication speed and excellent error detection ability. Many electronic control units are equipped onto a vehicle, and each control unit shares information and links with other control units during operation (not independent). In CAN communication, control units are connected with 2 communication lines (CAN H line, CAN L line) allowing a high rate of information transmission with less wiring. Each control unit transmits/receives data but selectively reads required data only.

DTC Logic

INFOID:000000005151906

DTC DETECTION LOGIC

DTC No.	Trouble diagnosis name	DTC detecting condition	Possible cause
P0607	CAN communication bus	When detecting error during the initial diagnosis of CAN controller of ECM.	• ECM

DTC CONFIRMATION PROCEDURE

1.PERFORM DTC CONFIRMATION PROCEDURE

1. Turn ignition switch ON.
2. Check DTC.

Is DTC detected?

- YES >> Go to [EC-363. "Diagnosis Procedure"](#).
- NO >> INSPECTION END

Diagnosis Procedure

INFOID:000000005151907

1.INSPECTION START

1. Turn ignition switch ON.
2. Erase DTC.
3. Perform DTC Confirmation Procedure.
See [EC-363. "DTC Logic"](#).
4. Check DTC.

Is the DTC P0607 displayed again?

- YES >> GO TO 2.
- NO >> INSPECTION END

2.REPLACE ECM

1. Replace ECM.
2. Go to [EC-16. "ADDITIONAL SERVICE WHEN REPLACING CONTROL UNIT \(ECM\) : Special Repair Requirement"](#).

>> INSPECTION END

P0643 SENSOR POWER SUPPLY

[VQ37VHR]

< DTC/CIRCUIT DIAGNOSIS >

P0643 SENSOR POWER SUPPLY

DTC Logic

INFOID:000000005151908

DTC DETECTION LOGIC

DTC No.	Trouble diagnosis name	DTC detecting condition	Possible cause
P0643	Sensor power supply circuit short	ECM detects that the voltage of power source for sensor is excessively low or high.	<ul style="list-style-type: none">• Harness or connectors (APP sensor 1 circuit is shorted.) (TP sensor circuit is shorted.) [CMP sensor (PHASE) (bank 1) circuit is shorted.] [Manifold absolute pressure (MAP) sensor circuit is shorted.] (PSP sensor circuit is shorted.) [CMP sensor (PHASE) (bank 2) circuit is shorted.] [Battery current sensor circuit is shorted/]• Accelerator pedal position sensor• Throttle position sensor• Camshaft position sensor (PHASE) (bank 1)• Manifold absolute pressure (MAP) sensor• Power steering pressure sensor• Camshaft position sensor (PHASE) (bank 2)• Battery current sensor

DTC CONFIRMATION PROCEDURE

1. PRECONDITIONING

If DTC Confirmation Procedure has been previously conducted, always perform the following procedure before conducting the next test.

1. Turn ignition switch OFF and wait at least 10 seconds.
2. Turn ignition switch ON.
3. Turn ignition switch OFF and wait at least 10 seconds.

TESTING CONDITION:

Before performing the following procedure, confirm that battery voltage is more than 10 V at idle.

>> GO TO 2.

2. PERFORM DTC CONFIRMATION PROCEDURE

1. Start engine and let it idle for 1 second.
2. Check DTC.

Is DTC detected?

- YES >> Go to [EC-364, "Diagnosis Procedure"](#).
NO >> INSPECTION END

Diagnosis Procedure

INFOID:000000005151909

1. CHECK GROUND CONNECTION

1. Turn ignition switch OFF.
2. Check ground connection M95. Refer to Ground Inspection in [GI-39, "Circuit Inspection"](#).

Is the inspection result normal?

- YES >> GO TO 2.
NO >> Repair or replace ground connection.

2. CHECK ACCELERATOR PEDAL POSITION SENSOR 1 POWER SUPPLY CIRCUIT

1. Disconnect accelerator pedal position (APP) sensor harness connector.
2. Turn ignition switch ON.
3. Check the voltage between APP sensor harness connector and ground.

P0643 SENSOR POWER SUPPLY

< DTC/CIRCUIT DIAGNOSIS >

[VQ37VHR]

APP sensor		Ground	Voltage (V)
Connector	Terminal		
E112	5	Ground	Approx. 5

Is the inspection result normal?

YES >> GO TO 7.

NO >> GO TO 3.

3.CHECK SENSOR POWER SUPPLY CIRCUITS

Check harness for short to power and short to ground, between the following terminals.

ECM		Sensor		
Connector	Terminal	Name	Connector	Terminal
F101	43	Electric throttle control actuator (bank 2)	F27	1
	44	Electric throttle control actuator (bank 1)	F6	6
F102	60	CMP sensor (PHASE) (bank 1)	F5	1
		Manifold absolute pressure (MAP) sensor	F50	1
		PSP sensor	F35	3
	64	CMP sensor (PHASE) (bank 2)	F18	1
Battery current sensor		E21	1	
M107	99	APP sensor	E112	5

Is the inspection result normal?

YES >> GO TO 4.

NO >> Repair short to ground or short to power in harness or connectors.

4.CHECK COMPONENTS

Check the following.

- Camshaft position sensor (PHASE) (bank 1) (Refer to [EC-275, "Component Inspection"](#).)
- Manifold absolute pressure (MAP) sensor (Refer to [EC-179, "Component Inspection"](#).)
- Power steering pressure sensor (Refer to [EC-352, "Component Inspection"](#).)
- Camshaft position sensor (PHASE) (bank 2) (Refer to [EC-275, "Component Inspection"](#).)
- Battery current sensor (Refer to [EC-416, "Component Inspection"](#).)

Is the inspection result normal?

YES >> GO TO 5.

NO >> Replace malfunctioning component.

5.CHECK TP SENSOR

Refer to [EC-192, "Component Inspection"](#).

Is the inspection result normal?

YES >> GO TO 9.

NO >> GO TO 6.

6.REPLACE ELECTRIC THROTTLE CONTROL ACTUATOR

1. Replace electric throttle control actuator.
2. Go to [EC-192, "Special Repair Requirement"](#).

>> INSPECTION END

7.CHECK APP SENSOR

Refer to [EC-465, "Component Inspection"](#).

Is the inspection result normal?

YES >> GO TO 9.

P0643 SENSOR POWER SUPPLY

[VQ37VHR]

< DTC/CIRCUIT DIAGNOSIS >

NO >> GO TO 8.

8. REPLACE ACCELERATOR PEDAL ASSEMBLY

1. Replace accelerator pedal assembly.
2. Go to [EC-465. "Special Repair Requirement"](#).

>> INSPECTION END

9. CHECK INTERMITTENT INCIDENT

Refer to [GI-36. "Intermittent Incident"](#).

>> INSPECTION END

P0850 PNP SWITCH

< DTC/CIRCUIT DIAGNOSIS >

[VQ37VHR]

P0850 PNP SWITCH

Description

INFOID:000000005151910

When the selector lever position is P or N, park/neutral position (PNP) signal from the TCM is sent to ECM.(A/T models)

When the selector lever position is Neutral position, park/neutral position (PNP) switch is ON.(M/T models)
ECM detects the position because the continuity of the line (the ON signal) exists.

DTC Logic

INFOID:000000005151911

DTC DETECTION LOGIC

DTC No.	Trouble diagnosis name	DTC detecting condition	Possible cause
P0850	Park/neutral position switch	The signal of the park/neutral position (PNP) signal does not change during driving after the engine is started.	<ul style="list-style-type: none"> Harness or connectors [The park/neutral position (PNP) signal circuit is open or shorted.] Park/neutral position (PNP) switch (M/T models) TCM (A/T models)

DTC CONFIRMATION PROCEDURE

1.INSPECTION START

Do you have CONSULT-III?

Do you have CONSULT-III?

YES >> GO TO 2.

NO >> GO TO 5.

2.PRECONDITIONING

If DTC Confirmation Procedure has been previously conducted, always perform the following procedure before conducting the next test.

1. Turn ignition switch OFF and wait at least 10 seconds.
2. Turn ignition switch ON.
3. Turn ignition switch OFF and wait at least 10 seconds.

>> GO TO 3.

3.CHECK PNP SWITCH SIGNAL (M/T) OR TRANSMISSION RANGE SWITCH SIGNAL (A/T)

Ⓜ With CONSULT-III

1. Turn ignition switch ON.
2. Select "P/N POSI SW" in "DATA MONITOR" mode with CONSULT-III. Then check the "P/N POSI SW" signal under the following conditions.

Position (Selector lever)	Known-good signal
N or P position (A/T) Neutral position (M/T)	ON
Except above position	OFF

Is the inspection result normal?

YES >> GO TO 4.

NO >> Go to [EC-368, "Diagnosis Procedure"](#).

4.PERFORM DTC CONFIRMATION PROCEDURE

1. Select "DATA MONITOR" mode with CONSULT-III.
2. Start engine and warm it up to normal operating temperature.
3. Maintain the following conditions for at least 50 consecutive seconds.

CAUTION:

Always drive vehicle at a safe speed.

< DTC/CIRCUIT DIAGNOSIS >

ENG SPEED	1,400 - 6,375 rpm
COOLAN TEMP/S	More than 70°C (158°F)
B/FUEL SCHDL	2.0 - 31.8 msec
VHCL SPEED SE	More than 64 km/h (40 mph)
Selector lever	Suitable position

4. Check 1st trip DTC.

Is 1st trip DTC detected?

- YES >> Go to [EC-368, "Diagnosis Procedure"](#).
- NO >> INSPECTION END

5.PERFORM COMPONENT FUNCTION CHECK

Perform component function check. Refer to [EC-368, "Component Function Check"](#).

NOTE:

Use component function check the overall function of the park/neutral position (PNP) signal circuit. During this check, a 1st trip DTC might not be confirmed.

Is the inspection result normal?

- YES >> INSPECTION END
- NO >> Go to [EC-368, "Diagnosis Procedure"](#).

Component Function Check

INFOID:000000005151912

1.PERFORM COMPONENT FUNCTION CHECK

1. Turn ignition switch ON.
2. Check the voltage between ECM harness connector terminals under the following conditions.

ECM			Condition	Voltage (V)
Connector	+	-		
	Terminal	Terminal		
M107	109	128	Selector lever	P or N (A/T) Neutral (M/T) Battery voltage
			Except above	Approx. 0

Is the inspection result normal?

- YES >> INSPECTION END
- NO >> Go to [EC-368, "Diagnosis Procedure"](#).

Diagnosis Procedure

INFOID:000000005151913

1.INSPECTION START

Check which type of transmission the vehicle is equipped with.

Which type of transmission?

- A/T >> GO TO 2.
- M/T >> GO TO 7.

2.CHECK DTC WITH TCM

Refer to [TM-150, "Diagnosis Description"](#).

Is the inspection result normal?

- YES >> GO TO 3.
- NO >> Repair or replace.

3.CHECK STARTING SYSTEM

Turn ignition switch OFF, then turn it to START.

Does starter motor operate?

P0850 PNP SWITCH

[VQ37VHR]

< DTC/CIRCUIT DIAGNOSIS >

- YES >> GO TO 4.
NO >> Check DTC with BCM. Refer to [BCS-32, "SIGNAL BUFFER : CONSULT-III Function \(BCM - SIGNAL BUFFER\)"](#).

4.CHECK TRANSMISSION RANGE SWITCH INPUT SIGNAL CIRCUIT FOR OPEN AND SHORT

1. Turn ignition switch OFF.
2. Disconnect A/T assembly harness connector.
3. Disconnect ECM harness connector.
4. Check the continuity between A/T assembly harness connector and ECM harness connector.

A/T assembly		ECM		Continuity
Connector	Terminal	Connector	Terminal	
F51	9	M107	109	Existed

5. Also check harness for short to ground and short to power.

Is the inspection result normal?

- YES >> GO TO 6.
NO >> GO TO 5.

5.DETECT MALFUNCTIONING PART

Check the following.

- Harness connectors F1, E3
- Harness connectors E106, M6
- Harness for open or short between A/T assembly and ECM

>> Repair open circuit, short to ground or short to power in harness or connectors.

6.CHECK INTERMITTENT INCIDENT

Refer to [GI-36, "Intermittent Incident"](#).

>> INSPECTION END

7.CHECK PNP SWITCH POWER SUPPLY CIRCUIT

1. Turn ignition switch OFF.
2. Disconnect park/neutral position (PNP) switch harness connector.
3. Turn ignition switch ON.
4. Check the voltage between PNP switch harness connector and ground.

PNP switch		Ground	Voltage
Connector	Terminal		
F55	2	Ground	Battery voltage

Is the inspection result normal?

- YES >> GO TO 9.
NO >> GO TO 8.

8.DETECT MALFUNCTIONING PART

Check the following.

- Harness connectors E3, F1
- 10 A fuse (No. 43)
- IPDM E/R harness connector E7
- Harness for open or short between PNP switch and fuse

>> Repair open circuit, short to ground or short to power in harness or connectors.

9.CHECK PNP SWITCH INPUT SIGNAL CIRCUIT FOR OPEN AND SHORT

1. Turn ignition switch OFF.
2. Disconnect ECM harness connector.

P0850 PNP SWITCH

[VQ37VHR]

< DTC/CIRCUIT DIAGNOSIS >

3. Check the continuity between PNP switch harness connector and ECM harness connector.

PNP switch		ECM		Continuity
Connector	Terminal	Connector	Terminal	
F55	1	M107	109	Existed

4. Also check harness for short to ground and short to power.

Is the inspection result normal?

YES >> GO TO 11.

NO >> GO TO 10.

10. DETECT MALFUNCTIONING PART

Check the following.

- Harness connectors F103, M116
- Harness for open or short between PNP switch and ECM

>> Repair open circuit, short to ground or short to power in harness or connectors.

11. CHECK PNP SWITCH

Refer to [TM-9, "Component Inspection"](#).

Is the inspection result normal?

YES >> GO TO 12.

NO >> Replace PNP switch.

12. CHECK INTERMITTENT INCIDENT

Refer to [GI-36, "Intermittent Incident"](#).

Is the inspection result normal?

YES >> Replace IPDM E/R.

NO >> Repair or replace.

P100A, P100B VVEL SYSTEM

< DTC/CIRCUIT DIAGNOSIS >

[VQ37VHR]

P100A, P100B VVEL SYSTEM

DTC Logic

INFOID:000000005151914

DTC DETECTION LOGIC

NOTE:

If DTC P100A or P100B is displayed with DTC P1090 or P1093, first perform the trouble diagnosis for DTC P1090 or P1093. Refer to [EC-384. "DTC Logic"](#).

DTC No.	Trouble diagnosis name	DTC detecting condition	Possible cause
P100A	VVEL response malfunction (bank 1)	Actual event response to target is poor.	<ul style="list-style-type: none">• Harness or connectors (VVEL actuator motor circuit is open or shorted.)• VVEL actuator motor• VVEL actuator sub assembly• VVEL ladder assembly• VVEL control module
P100B	VVEL response malfunction (bank 2)		

DTC CONFIRMATION PROCEDURE

1. PRECONDITIONING

If DTC Confirmation Procedure has been previously conducted, always perform the following procedure before conducting the next test.

1. Turn ignition switch OFF and wait at least 10 seconds.
2. Turn ignition switch ON.
3. Turn ignition switch OFF and wait at least 10 seconds.

TESTING CONDITION:

Before performing the following procedure, confirm that battery voltage is more than 10 V at idle.

>> GO TO 2.

2. PERFORM DTC CONFIRMATION PROCEDURE

1. Start engine.
2. Depress the accelerator pedal rapidly half or more under no load conditions, and then release it.
3. Wait at idle for 5 seconds or more.
4. Repeat steps 2 to 3 for three times.
5. Check 1st trip DTC.

Is DTC detected?

- YES >> Go to [EC-371. "Diagnosis Procedure"](#).
NO >> INSPECTION END

Diagnosis Procedure

INFOID:000000005151915

1. CHECK GROUND CONNECTION

1. Turn ignition switch OFF.
2. Check ground connections M95, E46. Refer to Ground Inspection in [GI-39. "Circuit Inspection"](#).

Is the inspection result normal?

- YES >> GO TO 2.
NO >> Repair or replace ground connection.

2. VVEL ACTUATOR MOTOR OUTPUT SIGNAL CIRCUIT FOR OPEN AND SHORT

1. Disconnect VVEL control module harness connector.
2. Disconnect VVEL actuator motor harness connector.
3. Check the continuity between VVEL control module harness connector and VVEL actuator motor harness connector.

P100A, P100B VVEL SYSTEM

[VQ37VHR]

< DTC/CIRCUIT DIAGNOSIS >

DTC No.	VVEL control module			VVEL actuator motor		Continuity	
	Bank	Connector	Terminal	Connector	Terminal		
P100A	1	E15	12	F48	1	Existed	
					2	Not existed	
			25		1	Not existed	
					2	Existed	
P100B	2			2	F49	1	Existed
						2	Not existed
				15		1	Not existed
						2	Existed

4. Also check harness for short to ground and power.

Is the inspection result normal?

YES >> GO TO 4.

NO >> GO TO 3.

3. DETECT MALFUNCTIONING PART

Check the following.

- Harness connectors F1, E3
- Harness for open or short between VVEL actuator motor and VVEL control module

>> Repair open circuit, short to ground or short to power in harness or connectors.

4. CHECK VVEL ACTUATOR MOTOR

Refer to [EC-373, "Component Inspection \(VVEL ACTUATOR MOTOR\)"](#).

Is the inspection result normal?

YES >> GO TO 6.

NO >> GO TO 5.

5. REPLACE VVEL ACTUATOR SUB ASSEMBLY

1. Replace VVEL actuator sub assembly.
2. Go to [EC-374, "Special Repair Requirement"](#).

>> INSPECTION END

6. CHECK INTERMITTENT INCIDENT

Refer to [GI-36, "Intermittent Incident"](#).

Is the inspection result normal?

YES >> GO TO 7.

NO >> Repair or replace.

7. REPLACE VVEL CONTROL MODULE

1. Replace VVEL control module.
2. Go to [EC-17, "ADDITIONAL SERVICE WHEN REPLACING CONTROL UNIT \(VVEL CONTROL MODULE\) : Special Repair Requirement"](#).

>> GO TO 8.

8. PERFORM DTC CONFIRMATION PROCEDURE

1. Turn ignition switch ON.
2. Erase DTC.
3. Perform DTC Confirmation Procedure.
See [EC-371, "DTC Logic"](#).

Is the DTC P100A or P100B displayed again?

P100A, P100B VVEL SYSTEM

[VQ37VHR]

< DTC/CIRCUIT DIAGNOSIS >

- YES >> GO TO 9.
- NO >> INSPECTION END

9. CHECK VVEL ACTUATOR SUB ASSEMBLY

Refer to [EC-373, "Component Inspection \(VVEL ACTUATOR SUB ASSEMBLY\)"](#).

Is the inspection result normal?

- YES >> GO TO 11.
- NO >> GO TO 10.

10. REPLACE VVEL ACTUATOR SUB ASSEMBLY

1. Replace VVEL actuator sub assembly.
2. Go to [EC-374, "Special Repair Requirement"](#).

>> INSPECTION END

11. CHECK VVEL LADDER ASSEMBLY

Refer to [EM-94, "Inspection"](#).

Is the inspection result normal?

- YES >> GO TO 13.
- NO >> GO TO 12.

12. REPLACE CYLINDER HEAD, VVEL LADDER ASSEMBLY AND VVEL ACTUATOR SUB ASSEMBLY

1. Replace cylinder head, VVEL ladder assembly and VVEL actuator sub assembly.
2. Go to [EC-374, "Special Repair Requirement"](#).

>> INSPECTION END

13. CHECK INTERMITTENT INCIDENT

Refer to [GI-36, "Intermittent Incident"](#).

>> INSPECTION END

Component Inspection (VVEL ACTUATOR MOTOR)

INFOID:000000005151916

1. CHECK VVEL ACTUATOR MOTOR

1. Turn ignition switch OFF.
2. Disconnect VVEL actuator motor harness connector.
3. Check resistance between VVEL actuator motor terminals as follows.

VVEL actuator motor	Resistance
Terminal	
1 and 2	16 Ω or less

Is the inspection result normal?

- YES >> INSPECTION END
- NO >> GO TO 2.

2. REPLACE VVEL ACTUATOR SUB ASSEMBLY

1. Replace VVEL actuator sub assembly.
2. Go to [EC-374, "Special Repair Requirement"](#).

>> INSPECTION END

Component Inspection (VVEL ACTUATOR SUB ASSEMBLY)

INFOID:000000005151917

1. CHECK VVEL ACTUATOR SUB ASSEMBLY

1. Turn ignition switch OFF.

P100A, P100B VVEL SYSTEM

[VQ37VHR]

< DTC/CIRCUIT DIAGNOSIS >

2. Remove VVEL actuator sub assembly. Refer to [EM-85. "Disassembly and Assembly"](#).
3. Turn the ball screw shaft to check that it works smoothly.

Is the inspection result normal?

- YES >> INSPECTION END
NO >> GO TO 2.

2.REPLACE VVEL ACTUATOR SUB ASSEMBLY

1. Replace VVEL actuator sub assembly.
2. Go to [EC-374. "Special Repair Requirement"](#).

>> INSPECTION END

Special Repair Requirement

INFOID:000000005151918

1.PERFORM VVEL CONTROL SHAFT POSITION SENSOR ADJUSTMENT

Refer to [EC-21. "VVEL CONTROL SHAFT POSITION SENSOR ADJUSTMENT : Special Repair Requirement"](#).

>> GO TO 2.

2.PERFORM IDLE AIR VOLUME LEARNING

Refer to [EC-19. "IDLE AIR VOLUME LEARNING : Special Repair Requirement"](#).

>> END

P1087, P1088 VVEL SYSTEM

< DTC/CIRCUIT DIAGNOSIS >

[VQ37VHR]

P1087, P1088 VVEL SYSTEM

DTC Logic

INFOID:000000005151919

DTC DETECTION LOGIC

NOTE:

If DTC P1087 or P1088 is displayed with DTC P1090 or P1093.

Perform the trouble diagnosis for DTC P1090 or P1093. Refer to [EC-380, "DTC Logic"](#).

DTC No.	Trouble diagnosis name	DTC detecting condition	Possible cause
P1087	VVEL small event angle malfunction (bank 1)	The event angle of VVEL control shaft is always small.	<ul style="list-style-type: none">• Harness or connectors (VVEL actuator motor circuit is open or shorted.)• VVEL actuator motor• VVEL actuator sub assembly• VVEL ladder assembly• VVEL control module
P1088	VVEL small event angle malfunction (bank 2)		

A
EC
C
D
E
F
G
H
I
J
K
L
M
N
O
P

P1089, P1092 VVEL CONTROL SHAFT POSITION SENSOR

< DTC/CIRCUIT DIAGNOSIS >

[VQ37VHR]

P1089, P1092 VVEL CONTROL SHAFT POSITION SENSOR

Description

INFOID:000000005151920

VVEL control shaft position sensor (1) is placed on VVEL actuator sub assembly and detects the control shaft position angle. A magnet is pressed into the arm on the edge of control shaft. The magnetic field changes as the magnet rotates together with the arm resulting in the output voltage change of the sensor. VVEL control module detects the actual position angle through the voltage change and sends the signal to ECM.

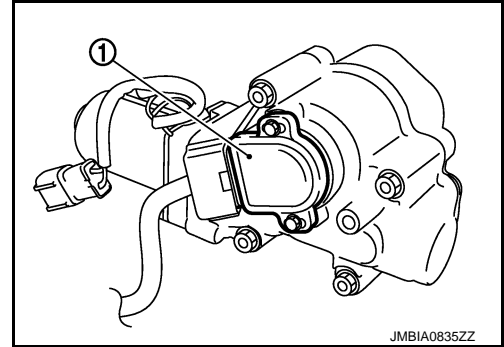

DTC Logic

INFOID:000000005151921

DTC DETECTION LOGIC

NOTE:

If DTC P1089 or P1092 is displayed with DTC P1608, first perform the trouble diagnosis for DTC P1608. Refer to [EC-457, "DTC Logic"](#).

DTC No.	Trouble diagnosis name	DTC detecting condition	Possible cause
P1089	VVEL control shaft position sensor (bank 1) circuit	<ul style="list-style-type: none">An excessively low voltage from the sensor is sent to VVEL control module.An excessively high voltage from the sensor is sent to VVEL control module.Rationally incorrect voltage is sent to VVEL control module compared with the signals from VVEL control shaft position sensor 1 and VVEL control shaft position sensor 2.	<ul style="list-style-type: none">Harness or connectors (VVEL control shaft position sensor circuit is open or shorted.)VVEL control shaft position sensorVVEL control module
P1092	VVEL control shaft position sensor (bank 2) circuit		

DTC CONFIRMATION PROCEDURE

1. PRECONDITIONING

If DTC Confirmation Procedure has been previously conducted, always perform the following procedure before conducting the next test.

- Turn ignition switch OFF and wait at least 10 seconds.
- Turn ignition switch ON.
- Turn ignition switch OFF and wait at least 10 seconds.

TESTING CONDITION:

Before performing the following procedure, confirm that battery voltage is more than 10 V at idle.

>> GO TO 2.

2. PERFORM DTC CONFIRMATION PROCEDURE

- Start engine and let it idle for 1 second.
- Check DTC.

Is DTC detected?

- YES >> Go to [EC-376, "Diagnosis Procedure"](#).
NO >> INSPECTION END

Diagnosis Procedure

INFOID:000000005151922

1. CHECK GROUND CONNECTION

- Turn ignition switch OFF.
- Check ground connections M95, E46. Refer to Ground Inspection in [GI-39, "Circuit Inspection"](#).

P1089, P1092 VVEL CONTROL SHAFT POSITION SENSOR

< DTC/CIRCUIT DIAGNOSIS >

[VQ37VHR]

Is the inspection result normal?

- YES >> GO TO 2.
NO >> Repair or replace ground connection.

2.VVEL CONTROL SHAFT POSITION SENSOR POWER SUPPLY CIRCUIT

1. Disconnect VVEL control shaft position sensor harness connector.
2. Turn ignition switch ON.
3. Check the voltage between VVEL control shaft position sensor harness connector and ground.

DTC No.	VVEL control shaft position sensor			Ground	Voltage (V)
	Bank	Connector	Terminal		
P1089	1	F46	3	Ground	Approx. 5
			6		
P1092	2	F47	3		
			6		

Is the inspection result normal?

- YES >> GO TO 4.
NO >> GO TO 3.

3.DETECT MALFUNCTIONING PART

Check the following.

- Harness connectors F1, E3
- Harness for open or short between VVEL control shaft position sensor and VVEL control module

>> Repair open circuit, short to ground or short to power in harness or connectors.

4.CHECK VVEL CONTROL SHAFT POSITION SENSOR GROUND CIRCUIT FOR OPEN AND SHORT

1. Turn ignition switch OFF.
2. Disconnect VVEL control module harness connector.
3. Check the continuity between VVEL control shaft position sensor harness connector and VVEL control module harness connector.

DTC No.	VVEL control shaft position sensor			VVEL control module		Continuity
	Bank	Connector	Terminal	Connector	Terminal	
P1089	1	F46	2	E15	4	Existed
			5		17	
P1092	2	F47	2		6	
			5		19	

4. Also check harness for short to ground and power.

Is the inspection result normal?

- YES >> GO TO 6.
NO >> GO TO 5.

5.DETECT MALFUNCTIONING PART

Check the following.

- Harness connectors F1, E3
- Harness for open or short between VVEL control shaft position sensor and VVEL control module

>> Repair open circuit, short to ground or short to power in harness or connectors.

6.VVEL CONTROL SHAFT POSITION SENSOR INPUT SIGNAL CIRCUIT FOR OPEN AND SHORT

1. Check the continuity between VVEL control shaft position sensor harness connector and VVEL control module harness connector.

P1089, P1092 VVEL CONTROL SHAFT POSITION SENSOR

< DTC/CIRCUIT DIAGNOSIS >

[VQ37VHR]

DTC No.	VVEL control shaft position sensor			VVEL control module		Continuity
	Bank	Connector	Terminal	Connector	Terminal	
P1089	1	F46	1	E15	3	Existed
			4		16	
P1092	2	F47	1		5	
			4		18	

2. Also check harness for short to ground and power.

Is the inspection result normal?

YES >> GO TO 8.

NO >> GO TO 7.

7. DETECT MALFUNCTIONING PART

Check the following.

- Harness connectors F1, E3
- Harness for open or short between VVEL control shaft position sensor and VVEL control module

>> Repair open circuit, short to ground or short to power in harness or connectors.

8. CHECK INTERMITTENT INCIDENT

Refer to [GI-36. "Intermittent Incident"](#).

Is the inspection result normal?

YES >> GO TO 9.

NO >> Repair or replace.

9. REPLACE VVEL CONTROL MODULE

1. Replace VVEL control module.
2. Go to [EC-17. "ADDITIONAL SERVICE WHEN REPLACING CONTROL UNIT \(VVEL CONTROL MODULE\) : Special Repair Requirement"](#).

>> GO TO 10.

10. PERFORM DTC CONFIRMATION PROCEDURE

1. Turn ignition switch ON.
2. Erase DTC.
3. Perform DTC Confirmation Procedure.
See [EC-376. "DTC Logic"](#).

Is the DTC P1089 or P1092 displayed again?

YES >> GO TO 11.

NO >> INSPECTION END

11. REPLACE VVEL ACTUATOR SUB ASSEMBLY

1. Replace VVEL actuator sub assembly.
2. Go to [EC-378. "Special Repair Requirement"](#).

>> INSPECTION END

Special Repair Requirement

INFOID:000000005151923

1. PERFORM VVEL CONTROL SHAFT POSITION SENSOR ADJUSTMENT

Refer to [EC-21. "VVEL CONTROL SHAFT POSITION SENSOR ADJUSTMENT : Special Repair Requirement"](#).

>> GO TO 2.

P1089, P1092 VVEL CONTROL SHAFT POSITION SENSOR

< DTC/CIRCUIT DIAGNOSIS >

[VQ37VHR]

2. PERFORM IDLE AIR VOLUME LEARNING

Refer to [EC-19. "IDLE AIR VOLUME LEARNING : Special Repair Requirement"](#).

>> END

A

EC

C

D

E

F

G

H

I

J

K

L

M

N

O

P

P1090, P1093 VVEL ACTUATOR MOTOR

< DTC/CIRCUIT DIAGNOSIS >

[VQ37VHR]

P1090, P1093 VVEL ACTUATOR MOTOR

Description

INFOID:000000005151924

The VVEL actuator motor rotates the control shaft according to the control signal from the VVEL control module. The VVEL control module judges whether the VVEL actuator motor controls the angle properly by the VVEL control shaft position sensor signal.

DTC Logic

INFOID:000000005151925

DTC DETECTION LOGIC

NOTE:

If DTC P1090 or P1093 is displayed with DTC P1091, first perform the trouble diagnosis for DTC P1091. Refer to [EC-384, "DTC Logic"](#).

DTC No.	Trouble diagnosis name	DTC detecting condition	Possible cause
P1090	VVEL system performance (bank 1)	<ul style="list-style-type: none">Event angle difference between the actual and the target is detected.Abnormal current is sent to VVEL actuator motor.	<ul style="list-style-type: none">Harness or connectors (VVEL actuator motor circuit is open or shorted.)VVEL actuator motorVVEL actuator sub assemblyVVEL ladder assemblyVVEL control module
P1093	VVEL system performance (bank 2)		

DTC CONFIRMATION PROCEDURE

1. PRECONDITIONING

If DTC Confirmation Procedure has been previously conducted, always perform the following procedure before conducting the next test.

- Turn ignition switch OFF and wait at least 10 seconds.
- Turn ignition switch ON.
- Turn ignition switch OFF and wait at least 10 seconds.

TESTING CONDITION:

Before performing the following procedure, confirm that battery voltage is more than 10 V at idle.

>> GO TO 2.

2. PERFORM DTC CONFIRMATION PROCEDURE

- Start engine and let it idle for 10 second.
- Keep the engine speed at about 3,500 rpm for at least 10 seconds under no load.
- Check DTC.

Is DTC detected?

- YES >> Go to [EC-380, "Diagnosis Procedure"](#).
NO >> INSPECTION END

Diagnosis Procedure

INFOID:000000005151926

1. CHECK GROUND CONNECTION

- Turn ignition switch OFF.
- Check ground connections M95, E46. Refer to Ground Inspection in [GI-39, "Circuit Inspection"](#).

Is the inspection result normal?

- YES >> GO TO 2.
NO >> Repair or replace ground connection.

2. VVEL ACTUATOR MOTOR OUTPUT SIGNAL CIRCUIT FOR OPEN AND SHORT

- Disconnect VVEL control module harness connector.
- Disconnect VVEL actuator motor harness connector.
- Check the continuity between VVEL control module harness connector and VVEL actuator motor harness connector.

P1090, P1093 VVEL ACTUATOR MOTOR

[VQ37VHR]

< DTC/CIRCUIT DIAGNOSIS >

DTC No.	VVEL control module			VVEL actuator motor		Continuity
	Bank	Connector	Terminal	Connector	Terminal	
P1090	1	E15	12	F48	1	Existed
					2	Not existed
			25		1	Not existed
					2	Existed
P1093	2		2	F49	1	Existed
					2	Not existed
			15		1	Not existed
					2	Existed

4. Also check harness for short to ground and power.

Is the inspection result normal?

YES >> GO TO 4.

NO >> GO TO 3.

3. DETECT MALFUNCTIONING PART

Check the following.

- Harness connectors F1, E3
- Harness for open or short between VVEL actuator motor and VVEL control module

>> Repair open circuit, short to ground or short to power in harness or connectors.

4. CHECK VVEL ACTUATOR MOTOR

Refer to [EC-382, "Component Inspection \(VVEL ACTUATOR MOTOR\)"](#).

Is the inspection result normal?

YES >> GO TO 6.

NO >> GO TO 5.

5. REPLACE VVEL ACTUATOR SUB ASSEMBLY

1. Replace VVEL actuator sub assembly.
2. Go to [EC-383, "Special Repair Requirement"](#).

>> INSPECTION END

6. CHECK INTERMITTENT INCIDENT

Refer to [GI-36, "Intermittent Incident"](#).

Is the inspection result normal?

YES >> GO TO 7.

NO >> Repair or replace.

7. REPLACE VVEL CONTROL MODULE

1. Replace VVEL control module.
2. Go to [EC-17, "ADDITIONAL SERVICE WHEN REPLACING CONTROL UNIT \(VVEL CONTROL MODULE\) : Special Repair Requirement"](#).

>> GO TO 8.

8. PERFORM DTC CONFIRMATION PROCEDURE

1. Turn ignition switch ON.
2. Erase DTC.
3. Perform DTC Confirmation Procedure.
See [EC-380, "DTC Logic"](#).

Is the DTC P1090 or P1093 displayed again?

P1090, P1093 VVEL ACTUATOR MOTOR

[VQ37VHR]

< DTC/CIRCUIT DIAGNOSIS >

- YES >> GO TO 9.
NO >> INSPECTION END

9. CHECK VVEL ACTUATOR SUB ASSEMBLY

Refer to [EC-382, "Component Inspection \(VVEL ACTUATOR SUB ASSEMBLY\)"](#).

Is the inspection result normal?

- YES >> GO TO 11.
NO >> GO TO 10.

10. REPLACE VVEL ACTUATOR SUB ASSEMBLY

1. Replace VVEL actuator sub assembly.
2. Go to [EC-383, "Special Repair Requirement"](#).

>> INSPECTION END

11. CHECK VVEL LADDER ASSEMBLY

Refer to [EM-94, "Inspection"](#).

Is the inspection result normal?

- YES >> GO TO 13.
NO >> GO TO 12.

12. REPLACE CYLINDER HEAD, VVEL LADDER ASSEMBLY AND VVEL ACTUATOR SUB ASSEMBLY

1. Replace cylinder head, VVEL ladder assembly and VVEL actuator sub assembly.
2. Go to [EC-383, "Special Repair Requirement"](#).

>> INSPECTION END

13. CHECK INTERMITTENT INCIDENT

Refer to [GI-36, "Intermittent Incident"](#).

>> INSPECTION END

Component Inspection (VVEL ACTUATOR MOTOR)

INFOID:000000005151927

1. CHECK VVEL ACTUATOR MOTOR

1. Turn ignition switch OFF.
2. Disconnect VVEL actuator motor harness connector.
3. Check resistance between VVEL actuator motor terminals as follows.

VVEL actuator motor	Resistance
Terminal	
1 and 2	16 Ω or less

Is the inspection result normal?

- YES >> INSPECTION END
NO >> GO TO 2.

2. REPLACE VVEL ACTUATOR SUB ASSEMBLY

1. Replace VVEL actuator sub assembly.
2. Go to [EC-383, "Special Repair Requirement"](#).

>> INSPECTION END

Component Inspection (VVEL ACTUATOR SUB ASSEMBLY)

INFOID:000000005151928

1. CHECK VVEL ACTUATOR SUB ASSEMBLY

1. Turn ignition switch OFF.

P1090, P1093 VVEL ACTUATOR MOTOR

[VQ37VHR]

< DTC/CIRCUIT DIAGNOSIS >

2. Remove VVEL actuator sub assembly. Refer to [EM-85, "Disassembly and Assembly"](#).
3. Turn the ball screw shaft to check that it works smoothly.

Is the inspection result normal?

- YES >> INSPECTION END
NO >> GO TO 2.

2.REPLACE VVEL ACTUATOR SUB ASSEMBLY

1. Replace VVEL actuator sub assembly.
2. Go to [EC-383, "Special Repair Requirement"](#).

>> INSPECTION END

Special Repair Requirement

INFOID:000000005151929

1.PERFORM VVEL CONTROL SHAFT POSITION SENSOR ADJUSTMENT

Refer to [EC-21, "VVEL CONTROL SHAFT POSITION SENSOR ADJUSTMENT : Special Repair Requirement"](#).

>> GO TO 2.

2.PERFORM IDLE AIR VOLUME LEARNING

Refer to [EC-19, "IDLE AIR VOLUME LEARNING : Special Repair Requirement"](#).

>> END

A
EC
C
D
E
F
G
H
I
J
K
L
M
N
O
P

P1091 VVEL ACTUATOR MOTOR RELAY

< DTC/CIRCUIT DIAGNOSIS >

[VQ37VHR]

P1091 VVEL ACTUATOR MOTOR RELAY

Description

INFOID:000000005151930

Power supply for the VVEL actuator motor is provided to the VVEL control module via VVEL actuator motor relay. VVEL actuator motor relay is ON/OFF controlled by the VVEL control module. In addition, when the VVEL actuator motor relay cannot be controlled by the VVEL control module for some reason, it ON/OFF controlled by ECM.

DTC Logic

INFOID:000000005151931

DTC DETECTION LOGIC

DTC No.	Trouble diagnosis name	DTC detecting condition	Possible cause
P1091	VVEL actuator motor relay circuit	<ul style="list-style-type: none"> VVEL control module detects the VVEL actuator motor relay is stuck OFF. VVEL control module detects the VVEL actuator motor relay is stuck ON. 	<ul style="list-style-type: none"> Harness or connectors (VVEL actuator motor relay circuit is open or shorted.) (Abort circuit is open or shorted.) VVEL actuator motor relay VVEL control module ECM

DTC CONFIRMATION PROCEDURE

1. PRECONDITIONING

If DTC Confirmation Procedure has been previously conducted, always perform the following procedure before conducting the next test.

- Turn ignition switch OFF and wait at least 10 seconds.
- Turn ignition switch ON.
- Turn ignition switch OFF and wait at least 10 seconds.

TESTING CONDITION:

Before performing the following procedure, confirm that battery voltage is more than 10 V at idle.

>> GO TO 2.

2. PERFORM DTC CONFIRMATION PROCEDURE

- Turn ignition switch ON and wait at least 1 seconds.
- Turn ignition switch OFF and wait at least 10 seconds.
- Turn ignition switch ON and wait at least 1 seconds.
- Check DTC.

Is DTC detected?

- YES >> Go to [EC-384, "Diagnosis Procedure"](#).
- NO >> INSPECTION END

Diagnosis Procedure

INFOID:000000005151932

1. VVEL ACTUATOR MOTOR RELAY POWER SUPPLY CIRCUIT-I

- Turn ignition switch OFF.
- Disconnect VVEL actuator motor relay.
- Check the voltage between VVEL actuator motor relay harness connector and ground.

VVEL actuator motor relay		Ground	Voltage
Connector	Terminal		
E16	1	Ground	Battery voltage
	5		

Is the inspection result normal?

- YES >> GO TO 3.
- NO >> GO TO 2.

P1091 VVEL ACTUATOR MOTOR RELAY

[VQ37VHR]

< DTC/CIRCUIT DIAGNOSIS >

2. DETECT MALFUNCTIONING PART

Check the following.

- 50 A fusible link (letter N)
- Harness for open or short between VVEL actuator motor relay and battery

>> Repair open circuit, short to ground or short to power in harness or connectors.

3. VVEL ACTUATOR MOTOR RELAY POWER SUPPLY CIRCUIT-II

1. Disconnect VVEL control module harness connector.
2. Check the continuity between VVEL actuator motor relay harness connector and VVEL control module harness connector.

VVEL control module		VVEL actuator motor relay		Continuity
Connector	Terminal	Connector	Terminal	
E15	23	E16	2	Existed

3. Also check harness for short to ground and power.

Is the inspection result normal?

YES >> GO TO 4.

NO >> Repair open circuit, short to ground or short to power in harness or connectors.

4. VVEL ACTUATOR MOTOR RELAY INPUT SIGNAL CIRCUIT FOR OPEN AND SHORT

1. Check the continuity between VVEL actuator motor relay harness connector and VVEL control module harness connector.

VVEL control module			VVEL actuator motor relay		Continuity
Bank	Connector	Terminal	Connector	Terminal	
1	E15	13	E16	3	Existed
2		1			

2. Also check harness for short to ground and power.

Is the inspection result normal?

YES >> GO TO 5.

NO >> Repair open circuit, short to ground or short to power in harness or connectors.

5. CHECK VVEL ACTUATOR MOTOR RELAY

Refer to [EC-386, "Component Inspection"](#).

Is the inspection result normal?

YES >> GO TO 6.

NO >> Replace VVEL actuator motor relay.

6. CHECK ABORT CIRCUIT FOR OPEN AND SHORT

1. Disconnect ECM harness connector.
2. Check the continuity between VVEL control module harness connector and ECM harness connector.

VVEL control module		ECM		Continuity
Connector	Terminal	Connector	Terminal	
E15	21	F101	28	Existed

3. Also check harness for short to ground and power.

Is the inspection result normal?

YES >> GO TO 8.

NO >> GO TO 7.

7. DETECT MALFUNCTIONING PART

Check the following.

A
EC
C
D
E
F
G
H
I
J
K
L
M
N
O
P

P1091 VVEL ACTUATOR MOTOR RELAY

[VQ37VHR]

< DTC/CIRCUIT DIAGNOSIS >

- Harness connector E3, F1
- Harness for open or short between ECM and VVEL control module

>> Repair open circuit, short to ground or short to power in harness or connectors.

8. CHECK INTERMITTENT INCIDENT

Refer to [GI-36, "Intermittent Incident"](#).

Is the inspection result normal?

YES >> GO TO 9.

NO >> Repair or replace.

9. REPLACE VVEL CONTROL MODULE

1. Replace VVEL control module.
2. Go to [EC-17, "ADDITIONAL SERVICE WHEN REPLACING CONTROL UNIT \(VVEL CONTROL MODULE\) : Special Repair Requirement"](#).

>> GO TO 10.

10. PERFORM DTC CONFIRMATION PROCEDURE

1. Turn ignition switch ON.
2. Erase DTC.
3. Perform DTC Confirmation Procedure.
See [EC-384, "DTC Logic"](#).

Is the DTC P1091 displayed again?

YES >> GO TO 11.

NO >> INSPECTION END

11. REPLACE ECM

1. Replace ECM.
2. Go to [EC-16, "ADDITIONAL SERVICE WHEN REPLACING CONTROL UNIT \(ECM\) : Special Repair Requirement"](#).

>> INSPECTION END

Component Inspection

INFOID:000000005151933

1. CHECK VVEL ACTUATOR MOTOR RELAY

1. Turn ignition switch OFF.
2. Remove VVEL actuator motor relay.
3. Check the continuity between VVEL actuator motor relay terminals under the following conditions.

Terminal	Condition	Continuity
3 and 5	12 V direct current supply between terminals 1 and 2	Existed
	No current supply	Not existed

Is the inspection result normal?

YES >> INSPECTION END

NO >> Replace VVEL actuator motor relay.

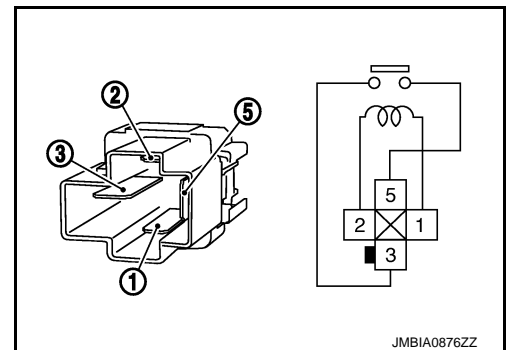

JMBIA0876ZZ

P1148, P1168 CLOSED LOOP CONTROL

< DTC/CIRCUIT DIAGNOSIS >

[VQ37VHR]

P1148, P1168 CLOSED LOOP CONTROL

DTC Logic

INFOID:000000005151934

DTC DETECTION LOGIC

NOTE:

DTC P1148 or P1168 is displayed with another DTC for A/F sensor 1. Perform the trouble diagnosis for the corresponding DTC.

DTC No.	Trouble diagnosis name	DTC detecting condition	Possible cause
P1148	Closed loop control function (bank 1)	The closed loop control function for bank 1 does not operate even when vehicle is being driven in the specified condition.	<ul style="list-style-type: none">• Harness or connectors (The A/F sensor 1 circuit is open or shorted.)• A/F sensor 1• A/F sensor 1 heater
P1168	Closed loop control function (bank 2)	The closed loop control function for bank 2 does not operate even when vehicle is being driven in the specified condition.	

A

EC

C

D

E

F

G

H

I

J

K

L

M

N

O

P

P1211 TCS CONTROL UNIT

< DTC/CIRCUIT DIAGNOSIS >

[VQ37VHR]

P1211 TCS CONTROL UNIT

Description

INFOID:000000005151935

The malfunction information related to TCS is transferred via the CAN communication line from “ABS actuator and electric unit (control unit)” to ECM.

Be sure to erase the malfunction information such as DTC not only for “ABS actuator and electric unit (control unit)” but also for ECM after TCS related repair.

DTC Logic

INFOID:000000005151936

DTC DETECTION LOGIC

Freeze frame data is not stored in the ECM for this self-diagnosis.

DTC No.	Trouble diagnosis name	DTC detecting condition	Possible cause
P1211	TCS control unit	ECM receives malfunction information from “ABS actuator and electric unit (control unit)”.	<ul style="list-style-type: none">• ABS actuator and electric unit (control unit)• TCS related parts

DTC CONFIRMATION PROCEDURE

1. PRECONDITIONING

TESTING CONDITION:

Before performing the following procedure, confirm that battery voltage is more than 10.5 V at idle.

>> GO TO 2.

2. PERFORM DTC CONFIRMATION PROCEDURE

1. Start engine and let it idle for at least 60 seconds.
2. Check 1st trip DTC.

Is 1st trip DTC detected?

- YES >> [EC-388. "Diagnosis Procedure"](#)
NO >> INSPECTION END

Diagnosis Procedure

INFOID:000000005151937

Go to [BRC-5. "Work Flow"](#).

P1212 TCS COMMUNICATION LINE

< DTC/CIRCUIT DIAGNOSIS >

[VQ37VHR]

P1212 TCS COMMUNICATION LINE

Description

INFOID:000000005151938

This CAN communication line is used to control the smooth engine operation during the TCS operation. Pulse signals are exchanged between ECM and "ABS actuator and electric unit (control unit)".

Be sure to erase the malfunction information such as DTC not only for "ABS actuator and electric unit (control unit)" but also for ECM after TCS related repair.

DTC Logic

INFOID:000000005151939

DTC DETECTION LOGIC

NOTE:

- If DTC P1212 is displayed with DTC UXXXX, first perform the trouble diagnosis for DTC UXXXX.
- If DTC P1212 is displayed with DTC P0607, first perform the trouble diagnosis for DTC P0607. Refer to [EC-363, "DTC Logic"](#).

Freeze frame data is not stored in the ECM for this self-diagnosis.

DTC No.	Trouble diagnosis name	DTC detecting condition	Possible cause
P1212	TCS communication line	ECM cannot receive the information from "ABS actuator and electric unit (control unit)" continuously.	<ul style="list-style-type: none">• Harness or connectors (The CAN communication line is open or shorted.)• ABS actuator and electric unit (control unit)• Dead (Weak) battery

DTC CONFIRMATION PROCEDURE

1. PRECONDITIONING

TESTING CONDITION:

Before performing the following procedure, confirm that battery voltage is more than 10.5 V at idle.

>> GO TO 2.

2. PERFORM DTC CONFIRMATION PROCEDURE

1. Start engine and let it idle for at least 10 seconds.
2. Check 1st trip DTC.

Is 1st trip DTC detected?

YES >> Go to [EC-389, "Diagnosis Procedure"](#).

NO >> INSPECTION END

Diagnosis Procedure

INFOID:000000005151940

Go to [BRC-5, "Work Flow"](#).

P1217 ENGINE OVER TEMPERATURE

< DTC/CIRCUIT DIAGNOSIS >

[VQ37VHR]

P1217 ENGINE OVER TEMPERATURE

DTC Logic

INFOID:000000005151941

DTC DETECTION LOGIC

NOTE:

- If DTC P1217 is displayed with DTC UXXXX, first perform the trouble diagnosis for DTC UXXXX.
- If DTC P1217 is displayed with DTC P0607, first perform the trouble diagnosis for DTC P0607. Refer to [EC-363, "DTC Logic"](#).

If the cooling fan or another component in the cooling system malfunctions, engine coolant temperature will rise.

When the engine coolant temperature reaches an abnormally high temperature condition, a malfunction is indicated.

DTC No.	Trouble diagnosis name	DTC detecting condition	Possible cause
P1217	Engine over temperature (Overheat)	<ul style="list-style-type: none">• Cooling fan does not operate properly (Overheat).• Cooling fan system does not operate properly (Overheat).• Engine coolant was not added to the system using the proper filling method.• Engine coolant is not within the specified range.	<ul style="list-style-type: none">• Harness or connectors (The cooling fan circuit is open or shorted.)• IPDM E/R• Cooling fan control module• Cooling fan motor• Radiator hose• Radiator• Radiator cap• Water pump• Thermostat

CAUTION:

When a malfunction is indicated, always replace the coolant. Refer to [CO-7, "Draining"](#) and [CO-8, "Refilling"](#). Also, replace the engine oil. Refer to [LU-7, "Draining"](#) and [LU-8, "Refilling"](#).

1. [MA-11, "Anti-Freeze Coolant Mixture Ratio"](#) Fill radiator with coolant up to specified level with a filling speed of 2 liters per minute. Always use coolant with the proper mixture ratio. Refer to .
2. After refilling coolant, run engine to ensure that no water-flow noise is emitted.

DTC CONFIRMATION PROCEDURE

1. PERFORM COMPONENT FUNCTION CHECK

Perform component function check. Refer to [EC-390, "Component Function Check"](#).

NOTE:

Use component function check to check the overall function of the cooling fan. During this check, a DTC might not be confirmed.

Is the inspection result normal?

YES >> INSPECTION END

NO >> Go to [EC-391, "Diagnosis Procedure"](#).

Component Function Check

INFOID:000000005151942

1. PERFORM COMPONENT FUNCTION CHECK-I

WARNING:

Never remove the radiator cap when the engine is hot. Serious burns could be caused by high pressure fluid escaping from the radiator.

Wrap a thick cloth around cap. Carefully remove the cap by turning it a quarter turn to allow built-up pressure to escape. Then turn the cap all the way off.

P1217 ENGINE OVER TEMPERATURE

[VQ37VHR]

< DTC/CIRCUIT DIAGNOSIS >

Check the coolant level in the reservoir tank and radiator.

Allow engine to cool before checking coolant level.

Is the coolant level in the reservoir tank and/or radiator below the proper range?

- YES >> Go to [EC-391, "Diagnosis Procedure"](#).
NO >> GO TO 2.

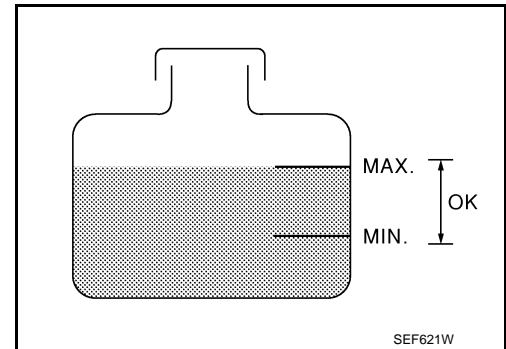

2.PERFORM COMPONENT FUNCTION CHECK-II

Confirm whether customer filled the coolant or not.

Did customer fill the coolant?

- YES >> Go to [EC-391, "Diagnosis Procedure"](#).
NO >> GO TO 3.

3.PERFORM COMPONENT FUNCTION CHECK-III

With CONSULT-III

1. Turn ignition switch ON.
2. Perform "FAN DUTY CONTROL" in "ACTIVE TEST" mode with CONSULT-III.
3. Make sure that cooling fan speed varies according to the percentage.

Without CONSULT-III

Perform IPDM E/R auto active test and check cooling fan motors operation, refer to [PCS-9, "Diagnosis Description"](#).

Is the inspection result normal?

- YES >> INSPECTION END
NO >> Go to [EC-391, "Diagnosis Procedure"](#).

Diagnosis Procedure

INFOID:000000005151943

1.CHECK COOLING FAN OPERATION

With CONSULT-III

1. Turn ignition switch ON.
2. Perform "FAN DUTY CONTROL" in "ACTIVE TEST" mode with CONSULT-III.
3. Make sure that cooling fan speed varies according to the percentage.

Without CONSULT-III

1. Perform IPDM E/R auto active test and check cooling fan motors operation, refer to [PCS-9, "Diagnosis Description"](#).
2. Make sure that cooling fan operates.

Is the inspection result normal?

- YES >> GO TO 2.
NO >> Go to [EC-486, "Diagnosis Procedure"](#).

2.CHECK COOLING SYSTEM FOR LEAK-I

Check cooling system for leak. Refer to [CO-7, "Inspection"](#).

Is leakage detected?

- YES >> GO TO 3.
NO >> GO TO 4.

3.CHECK COOLING SYSTEM FOR LEAK-II

Check the following for leak.

- Hose
- Radiator
- Water pump

P1217 ENGINE OVER TEMPERATURE

[VQ37VHR]

< DTC/CIRCUIT DIAGNOSIS >

>> Repair or replace malfunctioning part.

4. CHECK RADIATOR CAP

Check radiator cap. Refer to [CO-10, "RADIATOR CAP : Inspection"](#).

Is the inspection result normal?

YES >> GO TO 5.

NO >> Replace radiator cap.

5. CHECK THERMOSTAT

Check thermostat. Refer to [CO-20, "Inspection"](#).

Is the inspection result normal?

YES >> GO TO 6.

NO >> Replace thermostat

6. CHECK ENGINE COOLANT TEMPERATURE SENSOR

Refer to [EC-188, "Component Inspection"](#).

Is the inspection result normal?

YES >> GO TO 7.

NO >> Replace engine coolant temperature sensor.

7. CHECK MAIN 12 CAUSES

If the cause cannot be isolated, check the following.

Engine	Step	Inspection item	Equipment	Standard	Reference page
OFF	1	<ul style="list-style-type: none"> Blocked radiator Blocked condenser Blocked radiator grille Blocked bumper 	<ul style="list-style-type: none"> Visual 	No blocking	—
	2	<ul style="list-style-type: none"> Coolant mixture 	<ul style="list-style-type: none"> Coolant tester 	MA-11, "Anti-Freeze Coolant Mixture Ratio"	
	3	<ul style="list-style-type: none"> Coolant level 	<ul style="list-style-type: none"> Visual 	Coolant up to MAX level in reservoir tank and radiator filler neck	CO-7, "Inspection"
	4	<ul style="list-style-type: none"> Radiator cap 	<ul style="list-style-type: none"> Pressure tester 	CO-10, "RADIATOR CAP : Inspection"	
ON*2	5	<ul style="list-style-type: none"> Coolant leaks 	<ul style="list-style-type: none"> Visual 	No leaks	CO-7, "Inspection"
ON*2	6	<ul style="list-style-type: none"> Thermostat 	<ul style="list-style-type: none"> Touch the upper and lower radiator hoses 	Both hoses should be hot	CO-20, "Inspection"
ON*1	7	<ul style="list-style-type: none"> Cooling fan 	<ul style="list-style-type: none"> CONSULT-III 	Operating	EC-486, "Component Function Check"
OFF	8	<ul style="list-style-type: none"> Combustion gas leak 	<ul style="list-style-type: none"> Color checker chemical tester 4 Gas analyzer 	Negative	—
ON*3	9	<ul style="list-style-type: none"> Coolant temperature gauge 	<ul style="list-style-type: none"> Visual 	Gauge less than 3/4 when driving	—
		<ul style="list-style-type: none"> Coolant overflow to reservoir tank 	<ul style="list-style-type: none"> Visual 	No overflow during driving and idling	CO-7, "Inspection"
OFF*4	10	<ul style="list-style-type: none"> Coolant return from reservoir tank to radiator 	<ul style="list-style-type: none"> Visual 	Should be initial level in reservoir tank	CO-7, "Inspection"
OFF	11	<ul style="list-style-type: none"> Cylinder head 	<ul style="list-style-type: none"> Straight gauge feeler gauge 	0.1 mm (0.004 in) Maximum distortion (warping)	EM-107, "Inspection"
	12	<ul style="list-style-type: none"> Cylinder block and pistons 	<ul style="list-style-type: none"> Visual 	No scuffing on cylinder walls or piston	EM-121, "Inspection"

*1: Turn the ignition switch ON.

*2: Engine running at 3,000 rpm for 10 minutes.

*3: Drive at 90 km/h (55 MPH) for 30 minutes and then let idle for 10 minutes.

*4: After 60 minutes of cool down time.

For more information, refer to [CO-3, "Troubleshooting Chart"](#).

P1217 ENGINE OVER TEMPERATURE

< DTC/CIRCUIT DIAGNOSIS >

[VQ37VHR]

>> INSPECTION END

A

EC

C

D

E

F

G

H

I

J

K

L

M

N

O

P

P1225, P1234 TP SENSOR

Description

INFOID:000000005151944

Electric throttle control actuator consists of throttle control motor, throttle position sensor, etc. The throttle position sensor responds to the throttle valve movement.

The throttle position sensor has two sensors. These sensors are a kind of potentiometer which transform the throttle valve position into output voltage, and emit the voltage signals to the ECM. The ECM judges the current opening angle of the throttle valve from these signals and controls the throttle valve opening angle properly in response to driving condition via the throttle control motor.

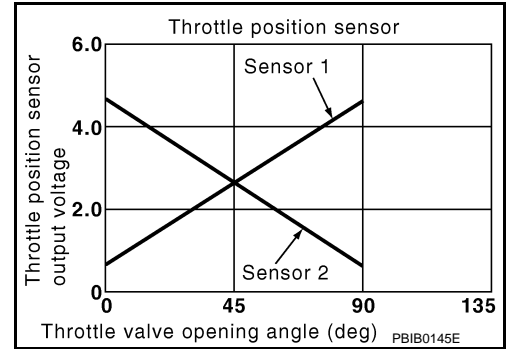

DTC Logic

INFOID:000000005151945

DTC DETECTION LOGIC

DTC No.	Trouble diagnosis name	DTC detecting condition	Possible cause
P1225	Closed throttle position learning performance (bank 1)	Closed throttle position learning value is excessively low.	<ul style="list-style-type: none"> Electric throttle control actuator (TP sensor 1 and 2)
P1234	Closed throttle position learning performance (bank 2)		

DTC CONFIRMATION PROCEDURE

1. PRECONDITIONING

If DTC Confirmation Procedure has been previously conducted, always perform the following procedure before conducting the next test.

1. Turn ignition switch OFF and wait at least 10 seconds.
2. Turn ignition switch ON.
3. Turn ignition switch OFF and wait at least 10 seconds.

TESTING CONDITION:

Before performing the following procedure, confirm that battery voltage is more than 10 V at idle.

>> GO TO 2.

2. PERFORM DTC CONFIRMATION PROCEDURE

1. Turn ignition switch ON.
2. Turn ignition switch OFF and wait at least 10 seconds.
3. Turn ignition switch ON.
4. Check 1st trip DTC.

Is 1st trip DTC detected?

- YES >> Go to [EC-394, "Diagnosis Procedure"](#).
- NO >> INSPECTION END

Diagnosis Procedure

INFOID:000000005151946

1. CHECK ELECTRIC THROTTLE CONTROL ACTUATOR VISUALLY

1. Turn ignition switch OFF.
2. Remove the intake air duct.

P1225, P1234 TP SENSOR

[VQ37VHR]

< DTC/CIRCUIT DIAGNOSIS >

3. Check if foreign matter is caught between the throttle valve (1) and the housing.

Is the inspection result normal?

- YES >> GO TO 2.
NO >> Remove the foreign matter and clean the electric throttle control actuator inside.

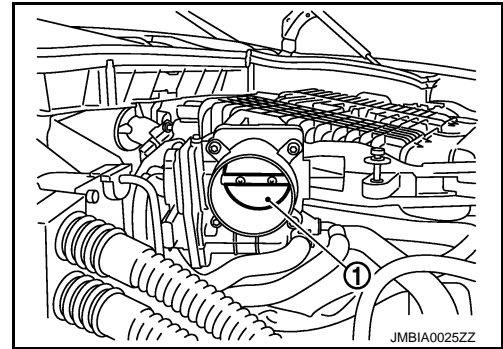

2. REPLACE ELECTRIC THROTTLE CONTROL ACTUATOR

1. Replace malfunctioning electric throttle control actuator.
2. Go to [EC-395, "Special Repair Requirement"](#).

>> INSPECTION END

Special Repair Requirement

INFOID:000000005151947

1. PERFORM THROTTLE VALVE CLOSED POSITION LEARNING

Refer to [EC-18, "THROTTLE VALVE CLOSED POSITION LEARNING : Special Repair Requirement"](#)

>> GO TO 2.

2. PERFORM IDLE AIR VOLUME LEARNING

Refer to [EC-19, "IDLE AIR VOLUME LEARNING : Special Repair Requirement"](#)

>> END

A
EC
C
D
E
F
G
H
I
J
K
L
M
N
O
P

P1226, P1235 TP SENSOR

< DTC/CIRCUIT DIAGNOSIS >

[VQ37VHR]

P1226, P1235 TP SENSOR

Description

INFOID:000000005151948

Electric throttle control actuator consists of throttle control motor, throttle position sensor, etc. The throttle position sensor responds to the throttle valve movement.

The throttle position sensor has two sensors. These sensors are a kind of potentiometer which transform the throttle valve position into output voltage, and emit the voltage signals to the ECM. The ECM judges the current opening angle of the throttle valve from these signals and controls the throttle valve opening angle properly in response to driving condition via the throttle control motor.

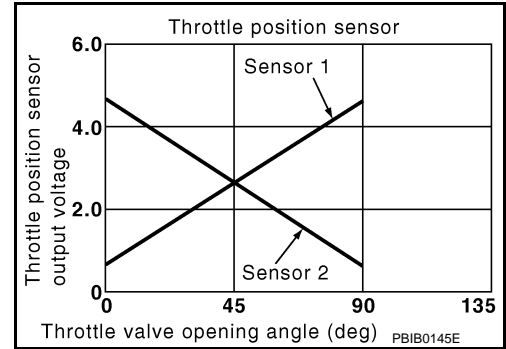

DTC Logic

INFOID:000000005151949

DTC DETECTION LOGIC

DTC No.	Trouble diagnosis name	DTC detecting condition	Possible cause
P1226	Closed throttle position learning performance (bank 1)	Closed throttle position learning is not performed successfully, repeatedly.	<ul style="list-style-type: none"> Electric throttle control actuator (TP sensor 1 and 2)
P1235	Closed throttle position learning performance (bank 2)		

DTC CONFIRMATION PROCEDURE

1. PRECONDITIONING

If DTC Confirmation Procedure has been previously conducted, always perform the following procedure before conducting the next test.

1. Turn ignition switch OFF and wait at least 10 seconds.
2. Turn ignition switch ON.
3. Turn ignition switch OFF and wait at least 10 seconds.

TESTING CONDITION:

Before performing the following procedure, confirm that battery voltage is more than 10 V at idle.

>> GO TO 2.

2. PERFORM DTC CONFIRMATION PROCEDURE

1. Turn ignition switch ON.
2. Turn ignition switch OFF and wait at least 10 seconds.
3. Turn ignition switch ON.
4. Repeat steps 2 and 3 for 32 times.
5. Check 1st trip DTC.

Is 1st trip DTC detected?

- YES >> Go to [EC-396, "Diagnosis Procedure"](#).
- NO >> INSPECTION END

Diagnosis Procedure

INFOID:000000005151950

1. CHECK ELECTRIC THROTTLE CONTROL ACTUATOR VISUALLY

1. Turn ignition switch OFF.
2. Remove the intake air duct.

P1226, P1235 TP SENSOR

[VQ37VHR]

< DTC/CIRCUIT DIAGNOSIS >

3. Check if foreign matter is caught between the throttle valve (1) and the housing.

Is the inspection result normal?

- YES >> GO TO 2.
NO >> Remove the foreign matter and clean the electric throttle control actuator inside.

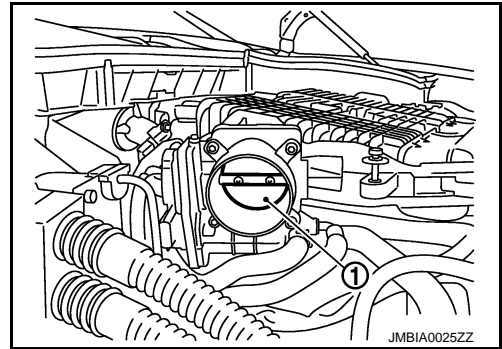

2. REPLACE ELECTRIC THROTTLE CONTROL ACTUATOR

1. Replace malfunctioning electric throttle control actuator.
2. Go to [EC-397, "Special Repair Requirement"](#).

>> INSPECTION END

Special Repair Requirement

INFOID:000000005151951

1. PERFORM THROTTLE VALVE CLOSED POSITION LEARNING

Refer to [EC-18, "THROTTLE VALVE CLOSED POSITION LEARNING : Special Repair Requirement"](#)

>> GO TO 2.

2. PERFORM IDLE AIR VOLUME LEARNING

Refer to [EC-19, "IDLE AIR VOLUME LEARNING : Special Repair Requirement"](#)

>> END

A
EC
C
D
E
F
G
H
I
J
K
L
M
N
O
P

P1233, P2101 ELECTRIC THROTTLE CONTROL FUNCTION

< DTC/CIRCUIT DIAGNOSIS >

[VQ37VHR]

P1233, P2101 ELECTRIC THROTTLE CONTROL FUNCTION

Description

INFOID:000000005151952

Electric throttle control actuator consists of throttle control motor, throttle position sensor, etc. The throttle control motor is operated by the ECM and it opens and closes the throttle valve. The current opening angle of the throttle valve is detected by the throttle position sensor and it provides feedback to the ECM to control the throttle control motor to make the throttle valve opening angle properly in response to driving condition.

DTC Logic

INFOID:000000005151953

DTC DETECTION LOGIC

NOTE:

If DTC P1233 or P2101 is displayed with DTC P1238, P1290, P2100 or 2119, first perform the trouble diagnosis for DTC P1238, P2119 or P1290, P2100. Refer to [EC-405, "DTC Logic"](#) or [EC-410, "DTC Logic"](#).

DTC No.	Trouble diagnosis name	DTC detecting condition	Possible cause
P1233	Electric throttle control performance (bank 2)	Electric throttle control function does not operate properly.	<ul style="list-style-type: none">• Harness or connectors (Throttle control motor circuit is open or shorted)• Electric throttle control actuator
P2101	Electric throttle control performance (bank 1)		

DTC CONFIRMATION PROCEDURE

1. PRECONDITIONING

If DTC Confirmation Procedure has been previously conducted, always perform the following procedure before conducting the next test.

1. Turn ignition switch OFF and wait at least 10 seconds.
2. Turn ignition switch ON.
3. Turn ignition switch OFF and wait at least 10 seconds.

TESTING CONDITION:

Before performing the following procedure, confirm that battery voltage is more than 11 V when engine is running.

>> GO TO 2.

2. PERFORM DTC CONFIRMATION PROCEDURE

1. Turn ignition switch ON and wait at least 2 seconds.
2. Start engine and let it idle for 5 seconds.
3. Check DTC.

Is DTC detected?

- YES >> Go to [EC-398, "Diagnosis Procedure"](#).
NO >> INSPECTION END

Diagnosis Procedure

INFOID:000000005151954

1. CHECK GROUND CONNECTION

1. Turn ignition switch OFF.
2. Check ground connection M95. Refer to Ground Inspection in [GI-39, "Circuit Inspection"](#).

Is the inspection result normal?

- YES >> GO TO 2.
NO >> Repair or replace ground connection.

2. CHECK THROTTLE CONTROL MOTOR RELAY INPUT SIGNAL CIRCUIT-I

Check the voltage between ECM harness connector terminals as per the following.

P1233, P2101 ELECTRIC THROTTLE CONTROL FUNCTION

< DTC/CIRCUIT DIAGNOSIS >

[VQ37VHR]

DTC	ECM				Condition	Voltage (V)	
	+		-				
	Connector	Terminal	Connector	Terminal			
P1233	F102	52	M107	128	Ignition switch	OFF	Approx. 0
							ON
P2101	F101	3				OFF	Approx. 0
				ON		Battery voltage	

Is the inspection result normal?

YES >> GO TO 9.

NO >> GO TO 3.

3. CHECK THROTTLE CONTROL MOTOR RELAY POWER SUPPLY CIRCUIT

- Turn ignition switch OFF.
- Disconnect ECM harness connector.
- Disconnect IPDM E/R harness connector E7.
- Check the continuity between IPDM E/R harness connector and ECM harness connector.

IPDM E/R		ECM		Continuity
Connector	Terminal	Connector	Terminal	
E7	70	F101	25	Existed

- Also check harness for short to ground and short to power.

Is the inspection result normal?

YES >> GO TO 5.

NO >> GO TO 4.

4. DETECT MALFUNCTIONING PART

Check the following.

- Harness connectors E3, F1
- Harness for open or short between ECM and IPDM E/R

>> Repair open circuit, short to ground or short to power in harness or connectors.

5. CHECK THROTTLE CONTROL MOTOR RELAY INPUT SIGNAL CIRCUIT-II

- Check the continuity between IPDM E/R harness connector and ECM harness connector.

DTC	IPDM E/R		ECM		Continuity
	Connector	Terminal	Connector	Terminal	
P1233	E7	54	F102	52	Existed
P2101			F101	3	

- Also check harness for short to ground and short to power.

Is the inspection result normal?

YES >> GO TO 7.

NO >> GO TO 6.

6. DETECT MALFUNCTIONING PART

Check the following.

- Harness connectors E3, F1
- Harness for open or short between ECM and IPDM E/R

>> Repair open circuit, short to ground or short to power in harness or connectors.

7. CHECK FUSE

P1233, P2101 ELECTRIC THROTTLE CONTROL FUNCTION

< DTC/CIRCUIT DIAGNOSIS >

[VQ37VHR]

1. Disconnect 15 A fuse (No. 51) from IPDM E/R.
2. Check 15 A fuse for blown.

Is the inspection result normal?

- YES >> GO TO 8.
NO >> Replace 15 A fuse.

8.CHECK INTERMITTENT INCIDENT

Refer to [GI-36. "Intermittent Incident"](#).

Is the inspection result normal?

- YES >> Replace IPDM E/R.
NO >> Repair or replace harness or connectors.

9.CHECK THROTTLE CONTROL MOTOR OUTPUT SIGNAL CIRCUIT FOR OPEN OR SHORT

1. Turn ignition switch OFF.
2. Disconnect electric throttle control actuator harness connector.
3. Disconnect ECM harness connector.
4. Check the continuity between electric throttle control actuator harness connector and ECM harness connector.

DTC	Electric throttle control actuator			ECM		Continuity
	Bank	Connector	Terminal	Connector	Terminal	
P1233	2	F27	5	F102	49	Existed
					50	Not existed
			6		49	Not existed
					50	Existed
P2101	1	F6	1	F101	2	Existed
					4	Not existed
			2		2	Not existed
					4	Existed

5. Also check harness for short to ground and short to power.

Is the inspection result normal?

- YES >> GO TO 10.
NO >> Repair or replace.

10.CHECK ELECTRIC THROTTLE CONTROL ACTUATOR VISUALLY

1. Remove the intake air duct.
2. Check if foreign matter is caught between the throttle valve (1) and the housing.

Is the inspection result normal?

- YES >> GO TO 11.
NO >> Remove the foreign matter and clean the electric throttle control actuator inside.

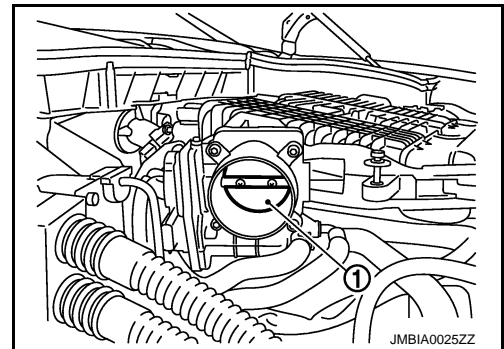

11.CHECK THROTTLE CONTROL MOTOR

Refer to [EC-401. "Component Inspection"](#).

Is the inspection result normal?

- YES >> GO TO 12.
NO >> GO TO 13.

12.CHECK INTERMITTENT INCIDENT

P1233, P2101 ELECTRIC THROTTLE CONTROL FUNCTION

< DTC/CIRCUIT DIAGNOSIS >

[VQ37VHR]

Refer to [GI-36. "Intermittent Incident"](#).

Is the inspection result normal?

YES >> GO TO 13.

NO >> Repair or replace harness or connectors.

13. REPLACE ELECTRIC THROTTLE CONTROL ACTUATOR

1. Replace malfunction electric throttle control actuator.
2. Go to [EC-401. "Special Repair Requirement"](#).

>> INSPECTION END

Component Inspection

INFOID:000000005151955

1. CHECK THROTTLE CONTROL MOTOR

1. Turn ignition switch OFF.
2. Disconnect electric throttle control actuator harness connector.
3. Check resistance between electric throttle control actuator terminals as per the following.

Electric throttle control actuator		Resistance (Ω)
Bank	Terminals	
1	1 and 2	Approx. 1 - 15 [at 25°C (77°F)]
2	5 and 6	

Is the inspection result normal?

YES >> INSPECTION END

NO >> GO TO 2.

2. REPLACE ELECTRIC THROTTLE CONTROL ACTUATOR

1. Replace malfunctioning electric throttle control actuator.
2. Go to [EC-401. "Special Repair Requirement"](#).

>> INSPECTION END

Special Repair Requirement

INFOID:000000005151956

1. PERFORM THROTTLE VALVE CLOSED POSITION LEARNING

Refer to [EC-18. "THROTTLE VALVE CLOSED POSITION LEARNING : Special Repair Requirement"](#)

>> GO TO 2.

2. PERFORM IDLE AIR VOLUME LEARNING

Refer to [EC-19. "IDLE AIR VOLUME LEARNING : Special Repair Requirement"](#)

>> END

P1236, P2118 THROTTLE CONTROL MOTOR

< DTC/CIRCUIT DIAGNOSIS >

[VQ37VHR]

P1236, P2118 THROTTLE CONTROL MOTOR

Description

INFOID:000000005151957

The throttle control motor is operated by the ECM and it opens and closes the throttle valve. The current opening angle of the throttle valve is detected by the throttle position sensor and it provides feedback to the ECM to control the throttle control motor to make the throttle valve opening angle properly in response to driving condition.

DTC Logic

INFOID:000000005151958

DTC DETECTION LOGIC

DTC No.	Trouble diagnosis name	DTC detecting condition	Possible cause
P1236	Throttle control motor (bank 2) circuit short	ECM detects short in both circuits between ECM and throttle control motor.	<ul style="list-style-type: none">• Harness or connectors (Throttle control motor circuit is shorted.)• Electric throttle control actuator (Throttle control motor)
P2118	Throttle control motor (bank 1) circuit short		

DTC CONFIRMATION PROCEDURE

1. PRECONDITIONING

If DTC Confirmation Procedure has been previously conducted, always perform the following procedure before conducting the next test.

1. Turn ignition switch OFF and wait at least 10 seconds.
2. Turn ignition switch ON.
3. Turn ignition switch OFF and wait at least 10 seconds.

>> GO TO 2.

2. PERFORM DTC CONFIRMATION PROCEDURE

1. Turn ignition switch ON and wait at least 2 seconds.
2. Start engine and let it idle for 5 seconds.
3. Check DTC.

Is DTC detected?

- YES >> Go to [EC-402, "Diagnosis Procedure"](#).
NO >> INSPECTION END

Diagnosis Procedure

INFOID:000000005151959

1. CHECK GROUND CONNECTION

1. Turn ignition switch OFF.
2. Check ground connection M95. Refer to Ground Inspection in [GI-39, "Circuit Inspection"](#).

Is the inspection result normal?

- YES >> GO TO 2.
NO >> Repair or replace ground connection.

2. CHECK THROTTLE CONTROL MOTOR OUTPUT SIGNAL CIRCUIT FOR OPEN AND SHORT

1. Disconnect electric throttle control actuator harness connector.
2. Disconnect ECM harness connector.
3. Check the continuity between electric throttle control actuator harness connector and ECM harness connector.

P1236, P2118 THROTTLE CONTROL MOTOR

< DTC/CIRCUIT DIAGNOSIS >

[VQ37VHR]

DTC	Electric throttle control actuator			ECM		Continuity
	Bank	Connector	Terminal	Connector	Terminal	
P1236	2	F27	5	F102	49	Existed
					50	Not existed
			6		49	Not existed
					50	Existed
P2118	1	F6	1	F101	2	Existed
					4	Not existed
			2		2	Not existed
					4	Existed

4. Also check harness for short to ground and short to power.

Is the inspection result normal?

YES >> GO TO 3.

NO >> Repair or replace.

3. CHECK THROTTLE CONTROL MOTOR

Refer to [EC-403. "Component Inspection"](#).

Is the inspection result normal?

YES >> GO TO 4.

NO >> GO TO 5.

4. CHECK INTERMITTENT INCIDENT

Refer to [GI-36. "Intermittent Incident"](#).

Is the inspection result normal?

YES >> GO TO 5.

NO >> Repair or replace harness or connectors.

5. REPLACE ELECTRIC THROTTLE CONTROL ACTUATOR

1. Replace malfunctioning electric throttle control actuator.

2. Go to [EC-404. "Special Repair Requirement"](#).

>> INSPECTION END

Component Inspection

INFOID:000000005151960

1. CHECK THROTTLE CONTROL MOTOR

1. Turn ignition switch OFF.

2. Disconnect electric throttle control actuator harness connector.

3. Check resistance between electric throttle control actuator terminals as per the following.

Electric throttle control actuator		Resistance (Ω)
Bank	Terminals	
1	1 and 2	Approx. 1 - 15 [at 25°C (77°F)]
2	5 and 6	

Is the inspection result normal?

YES >> INSPECTION END

NO >> GO TO 2.

2. REPLACE ELECTRIC THROTTLE CONTROL ACTUATOR

1. Replace malfunctioning electric throttle control actuator.

2. Go to [EC-404. "Special Repair Requirement"](#).

P1236, P2118 THROTTLE CONTROL MOTOR

< DTC/CIRCUIT DIAGNOSIS >

[VQ37VHR]

>> INSPECTION END

Special Repair Requirement

INFOID:000000005151961

1. PERFORM THROTTLE VALVE CLOSED POSITION LEARNING

Refer to [EC-18. "THROTTLE VALVE CLOSED POSITION LEARNING : Special Repair Requirement"](#)

>> GO TO 2.

2. PERFORM IDLE AIR VOLUME LEARNING

Refer to [EC-19. "IDLE AIR VOLUME LEARNING : Special Repair Requirement"](#)

>> END

P1238, P2119 ELECTRIC THROTTLE CONTROL ACTUATOR

< DTC/CIRCUIT DIAGNOSIS >

[VQ37VHR]

P1238, P2119 ELECTRIC THROTTLE CONTROL ACTUATOR

Description

INFOID:000000005151962

Electric throttle control actuator consists of throttle control motor, throttle position sensor, etc. The throttle control motor is operated by the ECM and it opens and closes the throttle valve. The throttle position sensor detects the throttle valve position and feeds the voltage signals to the ECM. The ECM judges the current opening angle of the throttle valve from these signals and controls the throttle valve opening angle properly in response to driving condition via the throttle control motor.

DTC Logic

INFOID:000000005151963

DTC DETECTION LOGIC

DTC No.	Trouble diagnosis name	DTC detecting condition		Possible cause
P1238	Electric throttle control actuator (bank 2)	A)	Electric throttle control actuator does not function properly due to the return spring malfunction.	• Electric throttle control actuator
		B)	Throttle valve opening angle in fail-safe mode is not in specified range.	
		C)	ECM detect the throttle valve is stuck open.	
P2119	Electric throttle control actuator (bank 1)	A)	Electric throttle control actuator does not function properly due to the return spring malfunction.	
		B)	Throttle valve opening angle in fail-safe mode is not in specified range.	
		C)	ECM detect the throttle valve is stuck open.	

DTC CONFIRMATION PROCEDURE

1. PRECONDITIONING

If DTC Confirmation Procedure has been previously conducted, always perform the following procedure before conducting the next test.

1. Turn ignition switch OFF and wait at least 10 seconds.
2. Turn ignition switch ON.
3. Turn ignition switch OFF and wait at least 10 seconds.

>> GO TO 2.

2. PERFORM DTC CONFIRMATION PROCEDURE FOR MALFUNCTION A AND B

1. Turn ignition switch ON and wait at least 1 second.
2. Shift selector lever to D position (A/T) or 1st position (M/T) and wait at least 3 seconds.
3. Shift selector lever to P position (A/T) or Neutral position (M/T).
4. Turn ignition switch OFF and wait at least 10 seconds.
5. Turn ignition switch ON and wait at least 1 second.
6. Shift selector lever to D position (A/T) or 1st position (M/T) and wait at least 3 seconds.
7. Shift selector lever to P position (A/T) or Neutral position (M/T).
8. Turn ignition switch OFF, wait at least 10 seconds, and then turn ON.
9. Check DTC.

Is DTC detected?

YES >> Go to [EC-406, "Diagnosis Procedure"](#).

NO >> GO TO 3.

3. PERFORM DTC CONFIRMATION PROCEDURE FOR MALFUNCTION C

1. Turn ignition switch ON and wait at least 1 second.
2. Shift selector lever to D position (A/T) or 1st position (M/T) and wait at least 3 seconds.
3. Shift selector lever to P position (A/T) or Neutral position (M/T).
4. Start engine and let it idle for 3 seconds.

P1238, P2119 ELECTRIC THROTTLE CONTROL ACTUATOR

[VQ37VHR]

< DTC/CIRCUIT DIAGNOSIS >

5. Check DTC.

Is DTC detected?

- YES >> Go to [EC-406. "Diagnosis Procedure"](#).
- NO >> INSPECTION END

Diagnosis Procedure

INFOID:000000005151964

1. CHECK ELECTRIC THROTTLE CONTROL ACTUATOR VISUALLY

1. Turn ignition switch OFF.
2. Remove the intake air duct.
3. Check if foreign matter is caught between the throttle valve (1) and the housing.

Is the inspection result normal?

- YES >> GO TO 2.
- NO >> Remove the foreign matter and clean the electric throttle control actuator inside.

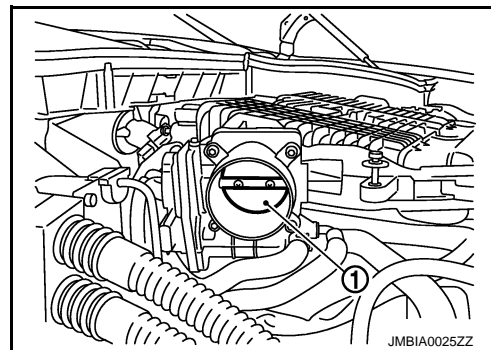

2. REPLACE ELECTRIC THROTTLE CONTROL ACTUATOR

1. Replace malfunctioning electric throttle control actuator.
2. Go to [EC-406. "Special Repair Requirement"](#).

>> INSPECTION END

Special Repair Requirement

INFOID:000000005151965

1. PERFORM THROTTLE VALVE CLOSED POSITION LEARNING

Refer to [EC-18. "THROTTLE VALVE CLOSED POSITION LEARNING : Special Repair Requirement"](#)

>> GO TO 2.

2. PERFORM IDLE AIR VOLUME LEARNING

Refer to [EC-19. "IDLE AIR VOLUME LEARNING : Special Repair Requirement"](#)

>> END

P1239, P2135 TP SENSOR

< DTC/CIRCUIT DIAGNOSIS >

[VQ37VHR]

P1239, P2135 TP SENSOR

Description

INFOID:000000005151966

Electric throttle control actuator consists of throttle control motor, throttle position sensor, etc. The throttle position sensor responds to the throttle valve movement.

The throttle position sensor has two sensors. These sensors are a kind of potentiometer which transform the throttle valve position into output voltage, and emit the voltage signals to the ECM. The ECM judges the current opening angle of the throttle valve from these signals and controls the throttle valve opening angle properly in response to driving condition via the throttle control motor.

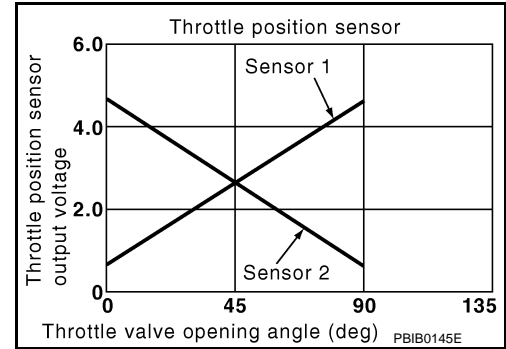

DTC Logic

INFOID:000000005151967

DTC DETECTION LOGIC

NOTE:

If DTC P1239 or P2135 is displayed with DTC P0643, first perform the trouble diagnosis for DTC P0643. Refer to [EC-364, "DTC Logic"](#).

DTC No.	Trouble diagnosis name	DTC detecting condition	Possible cause
P1239	Throttle position sensor (bank 2) circuit range/performance	Rationally incorrect voltage is sent to ECM compared with the signals from TP sensor 1 and TP sensor 2.	<ul style="list-style-type: none"> Harness or connector (TP sensor 1 or 2 circuit is open or shorted.) Electric throttle control actuator (TP sensor 1 or 2)
P2135	Throttle position sensor (bank 1) circuit range/performance		

DTC CONFIRMATION PROCEDURE

1. PRECONDITIONING

If DTC Confirmation Procedure has been previously conducted, always perform the following procedure before conducting the next test.

- Turn ignition switch OFF and wait at least 10 seconds.
- Turn ignition switch ON.
- Turn ignition switch OFF and wait at least 10 seconds.

TESTING CONDITION:

Before performing the following procedure, confirm that battery voltage is more than 10 V at idle.

>> GO TO 2.

2. PERFORM DTC CONFIRMATION PROCEDURE

- Start engine and let it idle for 1 second.
- Check DTC.

Is DTC detected?

YES >> Go to [EC-407, "Diagnosis Procedure"](#).

NO >> INSPECTION END

Diagnosis Procedure

INFOID:000000005151968

1. CHECK GROUND CONNECTION

- Turn ignition switch OFF.
- Check ground connection M95. Refer to Ground Inspection in [GI-39, "Circuit Inspection"](#).

Is the inspection result normal?

YES >> GO TO 2.

P1239, P2135 TP SENSOR

[VQ37VHR]

< DTC/CIRCUIT DIAGNOSIS >

NO >> Repair or replace ground connection.

2. CHECK THROTTLE POSITION SENSOR POWER SUPPLY CIRCUIT-I

1. Disconnect electric throttle control actuator harness connector.
2. Turn ignition switch ON.
3. Check the voltage between electric throttle control actuator harness connector and ground.

DTC	Electric throttle control actuator			Ground	Voltage (V)
	Bank	Connector	Terminal		
P1239	2	F27	1	Ground	Approx. 5
P2135	1	F6	6		

Is the inspection result normal?

YES >> GO TO 3.

NO >> Repair open circuit, short to ground or short to power in harness or connectors.

3. CHECK THROTTLE POSITION SENSOR GROUND CIRCUIT FOR OPEN AND SHORT

1. Turn ignition switch OFF.
2. Disconnect ECM harness connector.
3. Check the continuity between electric throttle control actuator harness connector and ECM harness connector.

DTC	Electric throttle control actuator			ECM		Continuity
	Bank	Connector	Terminal	Connector	Terminal	
P1239	2	F27	4	F101	48	Existed
P2135	1	F6	3		40	

4. Also check harness for short to ground and short to power.

Is the inspection result normal?

YES >> GO TO 4.

NO >> Repair open circuit, short to ground or short to power in harness or connectors.

4. CHECK THROTTLE POSITION SENSOR INPUT SIGNAL CIRCUIT FOR OPEN AND SHORT

1. Check the continuity between electric throttle control actuator harness connector and ECM harness connector.

DTC	Electric throttle control actuator			ECM		Continuity
	Bank	Connector	Terminal	Connector	Terminal	
P1239	2	F27	2	F101	31	Existed
			3		35	
P2135	1	F6	4		30	
			5		34	

2. Also check harness for short to ground and short to power.

Is the inspection result normal?

YES >> GO TO 5.

NO >> Repair open circuit, short to ground or short to power in harness or connectors.

5. CHECK THROTTLE POSITION SENSOR

Refer to [EC-409, "Component Inspection"](#).

Is the inspection result normal?

YES >> GO TO 7.

NO >> GO TO 6.

6. REPLACE ELECTRIC THROTTLE CONTROL ACTUATOR

1. Replace malfunctioning electric throttle control actuator.

P1239, P2135 TP SENSOR

< DTC/CIRCUIT DIAGNOSIS >

[VQ37VHR]

2. [EC-409. "Special Repair Requirement"](#).

>> INSPECTION END

7. CHECK INTERMITTENT INCIDENT

Refer to [GI-36. "Intermittent Incident"](#).

>> INSPECTION END

Component Inspection

INFOID:000000005151969

1. CHECK THROTTLE POSITION SENSOR

1. Turn ignition switch OFF.
2. Reconnect all harness connectors disconnected.
3. Perform [EC-18. "THROTTLE VALVE CLOSED POSITION LEARNING : Special Repair Requirement"](#).
4. Turn ignition switch ON.
5. Set selector lever to D (A/T) or 1st (M/T) position.
6. Check the voltage between ECM harness connector terminals as per the following.

Connector	ECM		Condition	Voltage (V)
	+	-		
	Terminal	Terminal		
F101	30 [TP sensor 1 (bank 1)]	40	Fully released	More than 0.36
			Fully depressed	Less than 4.75
	31 [TP sensor 1 (bank 2)]	48	Fully released	More than 0.36
			Fully depressed	Less than 4.75
	34 [TP sensor 2 (bank 1)]	40	Fully released	Less than 4.75
			Fully depressed	More than 0.36
	35 [TP sensor 2 (bank 2)]	48	Fully released	Less than 4.75
			Fully depressed	More than 0.36

Is the inspection result normal?

- YES >> INSPECTION END
NO >> GO TO 2.

2. REPLACE ELECTRIC THROTTLE CONTROL ACTUATOR

1. Replace malfunctioning electric throttle control actuator.
2. Go to [EC-409. "Special Repair Requirement"](#).

>> INSPECTION END

Special Repair Requirement

INFOID:000000005151970

1. PERFORM THROTTLE VALVE CLOSED POSITION LEARNING

Refer to [EC-18. "THROTTLE VALVE CLOSED POSITION LEARNING : Special Repair Requirement"](#)

>> GO TO 2.

2. PERFORM IDLE AIR VOLUME LEARNING

Refer to [EC-19. "IDLE AIR VOLUME LEARNING : Special Repair Requirement"](#)

>> END

P1290, P2100, P2103 THROTTLE CONTROL MOTOR RELAY

< DTC/CIRCUIT DIAGNOSIS >

[VQ37VHR]

P1290, P2100, P2103 THROTTLE CONTROL MOTOR RELAY

Description

INFOID:000000005151971

Power supply for the throttle control motor is provided to the ECM via throttle control motor relay. The throttle control motor relay is ON/OFF controlled by the ECM. When the ignition switch is turned ON, the ECM sends an ON signal to throttle control motor relay and battery voltage is provided to the ECM. When the ignition switch is turned OFF, the ECM sends an OFF signal to throttle control motor relay and battery voltage is not provided to the ECM.

DTC Logic

INFOID:000000005151972

DTC DETECTION LOGIC

DTC No.	Trouble diagnosis name	DTC detecting condition	Possible cause
P1290	Throttle control motor relay circuit open (bank 2)	ECM detects a voltage of power source for throttle control motor is excessively low.	<ul style="list-style-type: none">• Harness or connectors (Throttle control motor relay circuit is open)• Throttle control motor relay
P2100	Throttle control motor relay circuit open (bank 1)		
P2103	Throttle control motor relay circuit short	ECM detect the throttle control motor relay is stuck ON.	<ul style="list-style-type: none">• Harness or connectors (Throttle control motor relay circuit is shorted)• Throttle control motor relay

DTC CONFIRMATION PROCEDURE

1. PRECONDITIONING

If DTC Confirmation Procedure has been previously conducted, always perform the following procedure before conducting the next test.

1. Turn ignition switch OFF and wait at least 10 seconds.
2. Turn ignition switch ON.
3. Turn ignition switch OFF and wait at least 10 seconds.

TESTING CONDITION:

Before performing the following procedure, confirm that battery voltage is more than 8 V.

Which DTC is detected?

P1290, P2100 >> GO TO 2.

P2103 >> GO TO 3.

2. PERFORM DTC CONFIRMATION PROCEDURE FOR DTC P1290 AND P2100

1. Turn ignition switch ON and wait at least 2 seconds.
2. Start engine and let it idle for 5 seconds.
3. Check DTC.

Is DTC detected?

YES >> Go to [EC-410. "Diagnosis Procedure"](#).

NO >> INSPECTION END

3. PERFORM DTC CONFIRMATION PROCEDURE FOR DTC P2103

1. Turn ignition switch ON and wait at least 1 second.
2. Check DTC.

Is DTC detected?

YES >> Go to [EC-410. "Diagnosis Procedure"](#).

NO >> INSPECTION END

Diagnosis Procedure

INFOID:000000005151973

1. CHECK THROTTLE CONTROL MOTOR RELAY POWER SUPPLY CIRCUIT

1. Turn ignition switch OFF.
2. Disconnect ECM harness connector.

P1290, P2100, P2103 THROTTLE CONTROL MOTOR RELAY

[VQ37VHR]

< DTC/CIRCUIT DIAGNOSIS >

3. Disconnect IPDM E/R harness connector E7.
4. Check the continuity between IPDM E/R harness connector and ECM harness connector.

IPDM E/R		ECM		Continuity
Connector	Terminal	Connector	Terminal	
E7	70	F101	25	Existed

5. Also check harness for short to ground and short to power.

Is the inspection result normal?

YES >> GO TO 3.

NO >> GO TO 2.

2.DETECT MALFUNCTIONING PART

Check the following.

- Harness connectors E3, F1
- Harness for open or short between ECM and IPDM E/R

>> Repair open circuit, short to ground or short to power in harness or connectors.

3.CHECK THROTTLE CONTROL MOTOR RELAY INPUT SIGNAL CIRCUIT

1. Check the continuity between IPDM E/R sensor harness connector and ECM harness connector.

DTC	IPDM E/R		ECM		Continuity
	Connector	Terminal	Connector	Terminal	
P1290	E7	54	F102	52	Existed
P2100			F101	3	
P2103			F101	3	
			F102	52	

2. Also check harness for short to ground and short to power.

Is the inspection result normal?

YES >> GO TO 5.

NO >> GO TO 4.

4.DETECT MALFUNCTIONING PART

Check the following.

- Harness connectors E3, F1
- Harness for open or short between ECM and IPDM E/R

>> Repair open circuit, short to ground or short to power in harness or connectors.

5.CHECK FUSE

1. Disconnect 15 A fuse (No. 51) from IPDM E/R.
2. Check 15 A fuse for blown.

Is the inspection result normal?

YES >> GO TO 6.

NO >> Replace 15A fuse.

6.CHECK INTERMITTENT INCIDENT

Refer to [GI-36, "Intermittent Incident"](#).

Is the inspection result normal?

YES >> Replace IPDM E/R.

NO >> Repair or replace harness or connectors.

P1421 COLD START CONTROL

< DTC/CIRCUIT DIAGNOSIS >

[VQ37VHR]

P1421 COLD START CONTROL

Description

INFOID:000000005151974

ECM controls ignition timing and engine idle speed when engine is started with prewarming up condition. This control promotes the activation of three way catalyst by heating the catalyst and reduces emissions.

DTC Logic

INFOID:000000005151975

DTC DETECTION LOGIC

NOTE:

- If DTC P1421 is displayed with other DTC, first perform the trouble diagnosis for other DTC.

DTC No.	Trouble diagnosis name	DTC detecting condition	Possible cause
P1421	Cold start emission reduction strategy monitoring	ECM does not control ignition timing and engine idle speed properly when engine is started with prewarming up condition.	<ul style="list-style-type: none">• Lack of intake air volume• Fuel injection system• ECM

DTC CONFIRMATION PROCEDURE

1. PRECONDITIONING

If DTC Confirmation Procedure has been previously conducted, always perform the following procedure before conducting the next test.

1. Turn ignition switch OFF and wait at least 10 seconds.
2. Turn ignition switch ON.
3. Turn ignition switch OFF and wait at least 10 seconds.

TESTING CONDITION:

Before performing the following procedure, confirm that battery voltage is more than 11 V at idle.

>> GO TO 2.

2. PERFORM DTC CONFIRMATION PROCEDURE

1. Turn ignition switch OFF and wait at least 10 seconds.
2. Turn ignition switch ON.
3. Select "DATA MONITOR" mode with CONSULT-III.
4. Check the indication of "COOLAN TEMP/S".
If it is between 4°C (39°F) and 36°C (97°F), go to the following steps.
If it is below 4°C (39°F), warm engine up to more than 4°C (39°F) and retry from step 1.
If it is above 36°C (97°F), cool engine down to less than 36°C (97°F) and retry from step 1.
5. Start engine and let it idle for 5 minutes.
6. Check 1st trip DTC.

Is 1st trip DTC detected?

- YES >> Go to [EC-412, "Diagnosis Procedure"](#).
NO >> INSPECTION END

Diagnosis Procedure

INFOID:000000005151976

1. PERFORM IDLE AIR VOLUME LEARNING

Perform [EC-19, "IDLE AIR VOLUME LEARNING : Special Repair Requirement"](#).

Is Idle Air Volume Learning carried out successfully?

- YES >> GO TO 2.
NO >> Follow the instruction of Idle Air Volume Learning.

2. CHECK INTAKE SYSTEM

Check for the cause of intake air volume lacking. Refer to the following.

- Crushed intake air passage
- Intake air passage clogging

P1421 COLD START CONTROL

[VQ37VHR]

< DTC/CIRCUIT DIAGNOSIS >

Is the inspection result normal?

YES >> GO TO 3.

NO >> Repair or replace malfunctioning part

3.CHECK FUEL INJECTION SYSTEM FUNCTION

Perform DTC Confirmation Procedure for DTC P0171, P0174. Refer to [EC-236, "DTC Logic"](#).

Is the inspection result normal?

YES >> GO TO 4.

NO >> Go to [EC-237, "Diagnosis Procedure"](#) for DTC P0171, P0174.

4.PERFORM DTC CONFIRMATION PROCEDURE

1. Turn ignition switch ON.
2. Erase DTC.
3. **Perform DTC Confirmation Procedure.**
See [EC-412, "DTC Logic"](#).

Is the 1st trip DTC P1421 displayed again?

YES >> GO TO 5.

NO >> INSPECTION END

5.REPLACE ECM

1. Replace ECM.
2. Go to [EC-16, "ADDITIONAL SERVICE WHEN REPLACING CONTROL UNIT \(ECM\) : Special Repair Requirement"](#).

>> INSPECTION END

A

EC

C

D

E

F

G

H

I

J

K

L

M

N

O

P

P1550 BATTERY CURRENT SENSOR

< DTC/CIRCUIT DIAGNOSIS >

[VQ37VHR]

P1550 BATTERY CURRENT SENSOR

Description

INFOID:000000005151977

The power generation voltage variable control enables fuel consumption to be decreased by reducing the engine load which is caused by the power generation of the generator. The battery current sensor is installed to the battery cable at the negative terminal. The sensor measures the charging/discharging current of the battery. Based on the sensor signal, ECM judges whether or not the power generation voltage variable control is performed. When performing the power generation voltage variable control, ECM calculates the target power generation voltage based on the sensor signal. And ECM sends the calculated value as the power generation command value to IPDM E/R. For the details of the power generation voltage variable control, refer to [CHG-6, "System Description"](#).

CAUTION:

Never connect the electrical component or the ground wire directly to the battery terminal. The connection causes the malfunction of the power generation voltage variable control, and then battery discharge may occur.

DTC Logic

INFOID:000000005151978

DTC DETECTION LOGIC

NOTE:

If DTC P1550 is displayed with DTC P0643, first perform the trouble diagnosis for P0643. Refer to [EC-364, "DTC Logic"](#).

DTC No.	Trouble diagnosis name	DTC detecting condition	Possible cause
P1550	Battery current sensor circuit range/performance	The output voltage of the battery current sensor remains within the specified range while engine is running.	<ul style="list-style-type: none">• Harness or connectors (Battery current sensor circuit is open or shorted.)• Battery current sensor

DTC CONFIRMATION PROCEDURE

1. PRECONDITIONING

If DTC Confirmation Procedure has been previously conducted, always perform the following procedure before conducting the next test.

1. Turn ignition switch OFF and wait at least 10 seconds.
2. Turn ignition switch ON.
3. Turn ignition switch OFF and wait at least 10 seconds.

TESTING CONDITION:

Before performing the following procedure, confirm that battery voltage is more than 8 V at idle.

>> GO TO 2.

2. PERFORM DTC CONFIRMATION PROCEDURE

1. Start engine and wait at least 10 seconds.
2. Check 1st trip DTC.

Is 1st trip DTC detected?

YES >> Go to [EC-414, "Diagnosis Procedure"](#).

NO >> INSPECTION END

Diagnosis Procedure

INFOID:000000005151979

1. CHECK GROUND CONNECTION

1. Turn ignition switch OFF.
2. Check ground connection M95. Refer to Ground Inspection in [GI-39, "Circuit Inspection"](#).

Is the inspection result normal?

YES >> GO TO 2.

NO >> Repair or replace ground connection.

P1550 BATTERY CURRENT SENSOR

< DTC/CIRCUIT DIAGNOSIS >

[VQ37VHR]

2. CHECK BATTERY CURRENT SENSOR POWER SUPPLY CIRCUIT-I

1. Disconnect battery current sensor harness connector.
2. Turn ignition switch ON.
3. Check the voltage between battery current sensor harness connector and ground.

Battery current sensor		Ground	Voltage (V)
Connector	Terminal		
E21	1	Ground	Approx. 5

Is the inspection result normal?

YES >> GO TO 4.

NO >> GO TO 3.

3. DETECT MALFUNCTIONING PART

Check the following.

- Harness connectors F1, E3
- Harness for open or short between battery current sensor and ECM

>> Repair open circuit, short to ground or short to power in harness connectors.

4. CHECK BATTERY CURRENT SENSOR GROUND CIRCUIT FOR OPEN AND SHORT

1. Turn ignition switch OFF.
2. Disconnect ECM harness connector.
3. Check the continuity between battery current sensor harness connector and ECM harness connector.

Battery current sensor		ECM		Continuity
Connector	Terminal	Connector	Terminal	
E21	2	F102	95	Existed

4. Also check harness for short to ground and short to power.

Is the inspection result normal?

YES >> GO TO 6.

NO >> GO TO 5.

5. DETECT MALFUNCTIONING PART

Check the following.

- Harness connectors F1, E3
- Harness for open or short between battery current sensor and ECM

>> Repair open circuit, short to ground or short to power in harness or connectors.

6. CHECK BATTERY CURRENT SENSOR INPUT SIGNAL CIRCUIT FOR OPEN AND SHORT

1. Check the continuity between battery current sensor harness connector and ECM harness connector.

Battery current sensor		ECM		Continuity
Connector	Terminal	Connector	Terminal	
E21	3	F102	91	Existed

2. Also check harness for short to ground and short to power.

Is the inspection result normal?

YES >> GO TO 8.

NO >> GO TO 7.

7. DETECT MALFUNCTIONING PART

Check the following.

- Harness connectors F1, E3

P1550 BATTERY CURRENT SENSOR

[VQ37VHR]

< DTC/CIRCUIT DIAGNOSIS >

- Harness for open or short between battery current sensor and ECM

>> Repair open circuit, short to ground or short to power in harness or connectors.

8. CHECK BATTERY CURRENT SENSOR

Refer to [EC-416, "Component Inspection"](#).

Is the inspection result normal?

YES >> GO TO 9.

NO >> Replace battery negative cable assembly.

9. CHECK INTERMITTENT INCIDENT

Refer to [GI-36, "Intermittent Incident"](#).

>> INSPECTION END

Component Inspection

INFOID:000000005151980

1. CHECK BATTERY CURRENT SENSOR

1. Turn ignition switch OFF.
2. Reconnect harness connectors disconnected.
3. Disconnect battery negative cable (1).

←: To body ground

4. Install jumper cable (A) between battery negative terminal and body ground.
5. Turn ignition switch ON.
6. Check the voltage between ECM harness connector terminals as per the following.

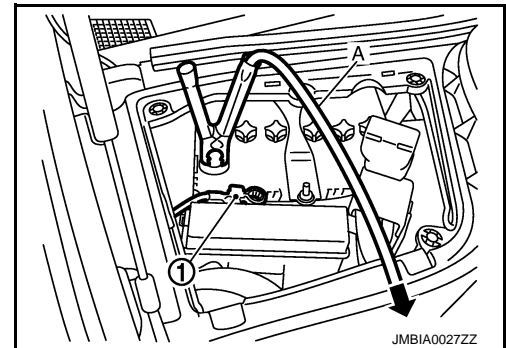

Connector	ECM		Voltage (V)
	+	-	
	Terminal	Terminal	
F102	91 (Battery current sensor signal)	95	Approx. 2.5

Before measuring the terminal voltage, confirm that the battery is fully charged. Refer to [PG-3, "How to Handle Battery"](#).

Is the inspection result normal?

YES >> INSPECTION END

NO >> Replace battery negative cable assembly.

P1551, P1552 BATTERY CURRENT SENSOR

[VQ37VHR]

< DTC/CIRCUIT DIAGNOSIS >

P1551, P1552 BATTERY CURRENT SENSOR

Description

INFOID:000000005151981

The power generation voltage variable control enables fuel consumption to be decreased by reducing the engine load which is caused by the power generation of the generator. The battery current sensor is installed to the battery cable at the negative terminal. The sensor measures the charging/discharging current of the battery. Based on the sensor signal, ECM judges whether or not the power generation voltage variable control is performed. When performing the power generation voltage variable control, ECM calculates the target power generation voltage based on the sensor signal. And ECM sends the calculated value as the power generation command value to IPDM E/R. For the details of the power generation voltage variable control, refer to [CHG-6, "System Description"](#).

CAUTION:

Never connect the electrical component or the ground wire directly to the battery terminal. The connection causes the malfunction of the power generation voltage variable control, and then battery discharge may occur.

DTC Logic

INFOID:000000005151982

DTC DETECTION LOGIC

NOTE:

If DTC P1551 or P1552 is displayed with DTC P0643, first perform the trouble diagnosis for DTC P0643. Refer to [EC-364, "DTC Logic"](#).

DTC No.	Trouble diagnosis name	DTC detecting condition	Possible cause
P1551	Battery current sensor circuit low input	An excessively low voltage from the sensor is sent to ECM.	• Harness or connectors (Battery current sensor circuit is open or shorted.) • Battery current sensor
P1552	Battery current sensor circuit high input	An excessively high voltage from the sensor is sent to ECM.	

DTC CONFIRMATION PROCEDURE

1. PRECONDITIONING

If DTC Confirmation Procedure has been previously conducted, always perform the following procedure before conducting the next test.

1. Turn ignition switch OFF and wait at least 10 seconds.
2. Turn ignition switch ON.
3. Turn ignition switch OFF and wait at least 10 seconds.

TESTING CONDITION:

Before performing the following procedure, confirm that battery voltage is more than 8 V with ignition switch ON

>> GO TO 2.

2. PERFORM DTC CONFIRMATION PROCEDURE

1. Turn ignition switch ON and wait at least 10 seconds.
2. Check 1st trip DTC.

Is 1st trip DTC detected?

YES >> Go to [EC-417, "Diagnosis Procedure"](#).

NO >> INSPECTION END

Diagnosis Procedure

INFOID:000000005151983

1. CHECK GROUND CONNECTION

1. Turn ignition switch OFF.
2. Check ground connection M95. Refer to Ground Inspection in [GI-39, "Circuit Inspection"](#).

Is the inspection result normal?

YES >> GO TO 2.

P1551, P1552 BATTERY CURRENT SENSOR

[VQ37VHR]

< DTC/CIRCUIT DIAGNOSIS >

NO >> Repair or replace ground connection.

2.CHECK BATTERY CURRENT SENSOR POWER SUPPLY CIRCUIT-I

1. Disconnect battery current sensor harness connector.
2. Turn ignition switch ON.
3. Check the voltage between battery current sensor harness connector and ground.

Battery current sensor		Ground	Voltage (V)
Connector	Terminal		
E21	1	Ground	Approx. 5

Is the inspection result normal?

- YES >> GO TO 4.
NO >> GO TO 3.

3.DETECT MALFUNCTIONING PART

Check the following.

- Harness connectors F1, E3
- Harness for open or short between battery current sensor and ECM

>> Repair open circuit, short to ground or short to power in harness connectors.

4.CHECK BATTERY CURRENT SENSOR GROUND CIRCUIT FOR OPEN AND SHORT

1. Turn ignition switch OFF.
2. Disconnect ECM harness connector.
3. Check the continuity between battery current sensor harness connector and ECM harness connector.

Battery current sensor		ECM		Continuity
Connector	Terminal	Connector	Terminal	
E21	2	F102	95	Existed

4. Also check harness for short to ground and short to power.

Is the inspection result normal?

- YES >> GO TO 6.
NO >> GO TO 5.

5.DETECT MALFUNCTIONING PART

Check the following.

- Harness connectors F1, E3
- Harness for open or short between battery current sensor and ECM

>> Repair open circuit, short to ground or short to power in harness or connectors.

6.CHECK BATTERY CURRENT SENSOR INPUT SIGNAL CIRCUIT FOR OPEN AND SHORT

1. Check the continuity between battery current sensor harness connector and ECM harness connector.

Battery current sensor		ECM		Continuity
Connector	Terminal	Connector	Terminal	
E21	3	F102	91	Existed

2. Also check harness for short to ground and short to power.

Is the inspection result normal?

- YES >> GO TO 8.
NO >> GO TO 7.

7.DETECT MALFUNCTIONING PART

Check the following.

P1551, P1552 BATTERY CURRENT SENSOR

[VQ37VHR]

< DTC/CIRCUIT DIAGNOSIS >

- Harness connectors F1, E3
- Harness for open or short between battery current sensor and ECM

>> Repair open circuit, short to ground or short to power in harness or connectors.

8. CHECK BATTERY CURRENT SENSOR

Refer to [EC-425, "Component Inspection"](#).

Is the inspection result normal?

YES >> GO TO 9.

NO >> Replace battery negative cable assembly.

9. CHECK INTERMITTENT INCIDENT

Refer to [GI-36, "Intermittent Incident"](#).

>> INSPECTION END

Component Inspection

INFOID:000000005151984

1. CHECK BATTERY CURRENT SENSOR

1. Turn ignition switch OFF.
2. Reconnect harness connectors disconnected.
3. Disconnect battery negative cable (1).

←: To body ground

4. Install jumper cable (A) between battery negative terminal and body ground.
5. Turn ignition switch ON.
6. Check the voltage between ECM harness connector terminals as per the following.

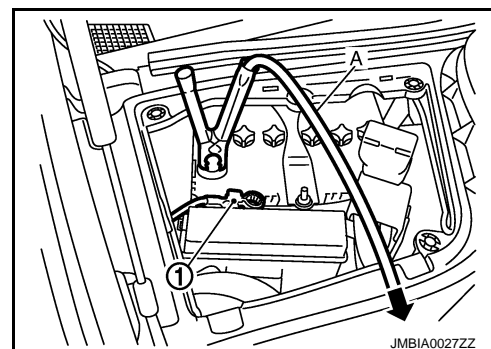

Connector	ECM		Voltage (V)
	+	-	
	Terminal	Terminal	
F102	91 (Battery current sensor signal)	95	Approx. 2.5

Before measuring the terminal voltage, confirm that the battery is fully charged. Refer to [PG-3, "How to Handle Battery"](#).

Is the inspection result normal?

YES >> INSPECTION END

NO >> Replace battery negative cable assembly.

P1553 BATTERY CURRENT SENSOR

< DTC/CIRCUIT DIAGNOSIS >

[VQ37VHR]

P1553 BATTERY CURRENT SENSOR

Description

INFOID:000000005151985

The power generation voltage variable control enables fuel consumption to be decreased by reducing the engine load which is caused by the power generation of the generator. The battery current sensor is installed to the battery cable at the negative terminal. The sensor measures the charging/discharging current of the battery. Based on the sensor signal, ECM judges whether or not the power generation voltage variable control is performed. When performing the power generation voltage variable control, ECM calculates the target power generation voltage based on the sensor signal. And ECM sends the calculated value as the power generation command value to IPDM E/R. For the details of the power generation voltage variable control, refer to [CHG-6, "System Description"](#).

CAUTION:

Never connect the electrical component or the ground wire directly to the battery terminal. The connection causes the malfunction of the power generation voltage variable control, and then battery discharge may occur.

DTC Logic

INFOID:000000005151986

DTC DETECTION LOGIC

NOTE:

If DTC P1553 is displayed with DTC P0643, first perform the trouble diagnosis for P0643. Refer to [EC-364, "DTC Logic"](#).

DTC No.	Trouble diagnosis name	DTC detecting condition	Possible cause
P1553	Battery current sensor performance	The signal voltage transmitted from the sensor to ECM is higher than the amount of the maximum power generation.	<ul style="list-style-type: none">• Harness or connectors (Battery current sensor circuit is open or shorted.)• Battery current sensor

DTC CONFIRMATION PROCEDURE

1. PRECONDITIONING

If DTC Confirmation Procedure has been previously conducted, always perform the following procedure before conducting the next test.

1. Turn ignition switch OFF and wait at least 10 seconds.
2. Turn ignition switch ON.
3. Turn ignition switch OFF and wait at least 10 seconds.

TESTING CONDITION:

Before performing the following procedure, confirm that battery voltage is more than 8 V at idle.

>> GO TO 2.

2. PERFORM DTC CONFIRMATION PROCEDURE

1. Start engine and wait at least 10 seconds.
2. Check 1st trip DTC.

Is 1st trip DTC detected?

YES >> Go to [EC-420, "Diagnosis Procedure"](#).

NO >> INSPECTION END

Diagnosis Procedure

INFOID:000000005151987

1. CHECK GROUND CONNECTION

1. Turn ignition switch OFF.
2. Check ground connection M95. Refer to Ground Inspection in [GI-39, "Circuit Inspection"](#).

Is the inspection result normal?

YES >> GO TO 2.

NO >> Repair or replace ground connection.

P1553 BATTERY CURRENT SENSOR

< DTC/CIRCUIT DIAGNOSIS >

[VQ37VHR]

2. CHECK BATTERY CURRENT SENSOR POWER SUPPLY CIRCUIT-I

1. Disconnect battery current sensor harness connector.
2. Turn ignition switch ON.
3. Check the voltage between battery current sensor harness connector and ground.

Battery current sensor		Ground	Voltage (V)
Connector	Terminal		
E21	1	Ground	Approx. 5

Is the inspection result normal?

YES >> GO TO 4.

NO >> GO TO 3.

3. DETECT MALFUNCTIONING PART

Check the following.

- Harness connectors F1, E3
- Harness for open or short between battery current sensor and ECM

>> Repair open circuit, short to ground or short to power in harness connectors.

4. CHECK BATTERY CURRENT SENSOR GROUND CIRCUIT FOR OPEN AND SHORT

1. Turn ignition switch OFF.
2. Disconnect ECM harness connector.
3. Check the continuity between battery current sensor harness connector and ECM harness connector.

Battery current sensor		ECM		Continuity
Connector	Terminal	Connector	Terminal	
E21	2	F102	95	Existed

4. Also check harness for short to ground and short to power.

Is the inspection result normal?

YES >> GO TO 6.

NO >> GO TO 5.

5. DETECT MALFUNCTIONING PART

Check the following.

- Harness connectors F1, E3
- Harness for open or short between battery current sensor and ECM

>> Repair open circuit, short to ground or short to power in harness or connectors.

6. CHECK BATTERY CURRENT SENSOR INPUT SIGNAL CIRCUIT FOR OPEN AND SHORT

1. Check the continuity between battery current sensor harness connector and ECM harness connector.

Battery current sensor		ECM		Continuity
Connector	Terminal	Connector	Terminal	
E21	3	F102	91	Existed

2. Also check harness for short to ground and short to power.

Is the inspection result normal?

YES >> GO TO 8.

NO >> GO TO 7.

7. DETECT MALFUNCTIONING PART

Check the following.

- Harness connectors F1, E3

P1553 BATTERY CURRENT SENSOR

[VQ37VHR]

< DTC/CIRCUIT DIAGNOSIS >

- Harness for open or short between battery current sensor and ECM

>> Repair open circuit, short to ground or short to power in harness or connectors.

8. CHECK BATTERY CURRENT SENSOR

Refer to [EC-425, "Component Inspection"](#).

Is the inspection result normal?

YES >> GO TO 9.

NO >> Replace battery negative cable assembly.

9. CHECK INTERMITTENT INCIDENT

Refer to [GI-36, "Intermittent Incident"](#).

>> INSPECTION END

Component Inspection

INFOID:000000005151988

1. CHECK BATTERY CURRENT SENSOR

1. Turn ignition switch OFF.
2. Reconnect harness connectors disconnected.
3. Disconnect battery negative cable (1).

←: To body ground

4. Install jumper cable (A) between battery negative terminal and body ground.
5. Turn ignition switch ON.
6. Check the voltage between ECM harness connector terminals as per the following.

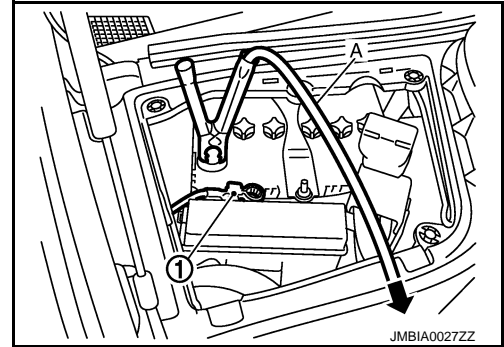

Connector	ECM		Voltage (V)
	+	-	
	Terminal	Terminal	
F102	91 (Battery current sensor signal)	95	Approx. 2.5

Before measuring the terminal voltage, confirm that the battery is fully charged. Refer to [PG-3, "How to Handle Battery"](#).

Is the inspection result normal?

YES >> INSPECTION END

NO >> Replace battery negative cable assembly.

P1554 BATTERY CURRENT SENSOR

< DTC/CIRCUIT DIAGNOSIS >

[VQ37VHR]

P1554 BATTERY CURRENT SENSOR

Description

INFOID:000000005151989

The power generation voltage variable control enables fuel consumption to be decreased by reducing the engine load which is caused by the power generation of the generator. The battery current sensor is installed to the battery cable at the negative terminal. The sensor measures the charging/discharging current of the battery. Based on the sensor signal, ECM judges whether or not the power generation voltage variable control is performed. When performing the power generation voltage variable control, ECM calculates the target power generation voltage based on the sensor signal. And ECM sends the calculated value as the power generation command value to IPDM E/R. For the details of the power generation voltage variable control, refer to [CHG-6, "System Description"](#).

CAUTION:

Never connect the electrical component or the ground wire directly to the battery terminal. The connection causes the malfunction of the power generation voltage variable control, and then battery discharge may occur.

DTC Logic

INFOID:000000005151990

DTC DETECTION LOGIC

NOTE:

If DTC P1554 is displayed with DTC P0643, first perform the trouble diagnosis for DTC P0643. Refer to [EC-364, "DTC Logic"](#).

DTC No.	Trouble diagnosis name	DTC detecting condition	Possible cause
P1554	Battery current sensor performance	The output voltage of the battery current sensor is lower than the specified value while the battery voltage is high enough.	<ul style="list-style-type: none">• Harness or connectors (Battery current sensor circuit is open or shorted.)• Battery current sensor

DTC CONFIRMATION PROCEDURE

1. PERFORM COMPONENT FUNCTION CHECK

Perform component function check. Refer to [EC-423, "Component Function Check"](#).

NOTE:

Use component function check to check the overall function of the battery current sensor circuit. During this check, a 1st trip DTC might not be confirmed.

Is the inspection result normal?

YES >> INSPECTION END

NO >> Go to [EC-424, "Diagnosis Procedure"](#).

Component Function Check

INFOID:000000005151991

1. PRECONDITIONING

TESTING CONDITION:

- Before performing the following procedure, confirm that battery voltage is more than 12.8 V at idle.
- Before performing the following procedure, confirm that all load switches and A/C switch are turned OFF.

>> GO TO 2.

2. PERFORM COMPONENT FUNCTION CHECK

Ⓜ With CONSULT-III

1. Start engine and let it idle.
2. Select "BAT CUR SEN" in "DATA MONITOR" mode with CONSULT-III.
3. Check "BAT CUR SEN" indication for 10 seconds.
"BAT CUR SEN" should be above 2,300 mV at least once.

ⓧ Without CONSULT-III

1. Start engine and let it idle.

P1554 BATTERY CURRENT SENSOR

[VQ37VHR]

< DTC/CIRCUIT DIAGNOSIS >

2. Check the voltage between ECM harness connector terminals as per the following.

ECM			Voltage (V)
Connector	+	-	
	Terminal	Terminal	
F102	91 (Battery current sensor signal)	95	Above 2.3 at least once

Is the inspection result normal?

YES >> INSPECTION END

NO >> Go to [EC-424, "Diagnosis Procedure"](#)

Diagnosis Procedure

INFOID:000000005151992

1. CHECK GROUND CONNECTION

1. Turn ignition switch OFF.
2. Check ground connection M95. Refer to Ground Inspection in [GI-39, "Circuit Inspection"](#).

Is the inspection result normal?

YES >> GO TO 2.

NO >> Repair or replace ground connection.

2. CHECK BATTERY CURRENT SENSOR POWER SUPPLY CIRCUIT-I

1. Disconnect battery current sensor harness connector.
2. Turn ignition switch ON.
3. Check the voltage between battery current sensor harness connector and ground.

Battery current sensor		Ground	Voltage (V)
Connector	Terminal		
E21	1	Ground	Approx. 5

Is the inspection result normal?

YES >> GO TO 4.

NO >> GO TO 3.

3. DETECT MALFUNCTIONING PART

Check the following.

- Harness connectors F1, E3
- Harness for open or short between battery current sensor and ECM

>> Repair open circuit, short to ground or short to power in harness connectors.

4. CHECK BATTERY CURRENT SENSOR GROUND CIRCUIT FOR OPEN AND SHORT

1. Turn ignition switch OFF.
2. Disconnect ECM harness connector.
3. Check the continuity between battery current sensor harness connector and ECM harness connector.

Battery current sensor		ECM		Continuity
Connector	Terminal	Connector	Terminal	
E21	2	F102	95	Existed

4. Also check harness for short to ground and short to power.

Is the inspection result normal?

YES >> GO TO 6.

NO >> GO TO 5.

5. DETECT MALFUNCTIONING PART

Check the following.

P1554 BATTERY CURRENT SENSOR

[VQ37VHR]

< DTC/CIRCUIT DIAGNOSIS >

- Harness connectors F1, E3
- Harness for open or short between battery current sensor and ECM

>> Repair open circuit, short to ground or short to power in harness or connectors.

6. CHECK BATTERY CURRENT SENSOR INPUT SIGNAL CIRCUIT FOR OPEN AND SHORT

1. Check the continuity between battery current sensor harness connector and ECM harness connector.

Battery current sensor		ECM		Continuity
Connector	Terminal	Connector	Terminal	
E21	3	F102	91	Existed

2. Also check harness for short to ground and short to power.

Is the inspection result normal?

- YES >> GO TO 8.
NO >> GO TO 7.

7. DETECT MALFUNCTIONING PART

Check the following.

- Harness connectors F1, E3
- Harness for open or short between battery current sensor and ECM

>> Repair open circuit, short to ground or short to power in harness or connectors.

8. CHECK BATTERY CURRENT SENSOR

Refer to [EC-425, "Component Inspection"](#).

Is the inspection result normal?

- YES >> GO TO 9.
NO >> Replace battery negative cable assembly.

9. CHECK INTERMITTENT INCIDENT

Refer to [GI-36, "Intermittent Incident"](#).

>> INSPECTION END

Component Inspection

INFOID:000000005151993

1. CHECK BATTERY CURRENT SENSOR

1. Turn ignition switch OFF.
2. Reconnect harness connectors disconnected.
3. Disconnect battery negative cable (1).

←: To body ground

4. Install jumper cable (A) between battery negative terminal and body ground.
5. Turn ignition switch ON.
6. Check the voltage between ECM harness connector terminals as per the following.

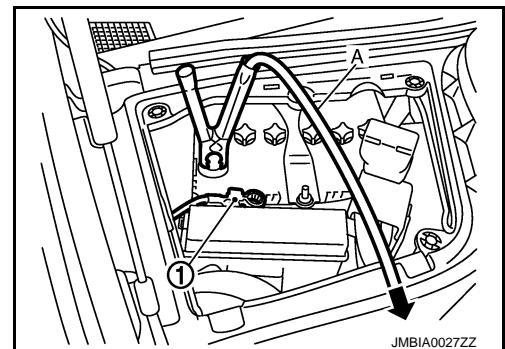

Connector	ECM		Voltage (V)
	+	-	
	Terminal	Terminal	
F102	91 (Battery current sensor signal)	95	Approx. 2.5

Before measuring the terminal voltage, confirm that the battery is fully charged. Refer to [PG-3, "How to Handle Battery"](#).

P1554 BATTERY CURRENT SENSOR

[VQ37VHR]

< DTC/CIRCUIT DIAGNOSIS >

Is the inspection result normal?

YES >> INSPECTION END

NO >> Replace battery negative cable assembly.

P1564 ASCD STEERING SWITCH

< DTC/CIRCUIT DIAGNOSIS >

[VQ37VHR]

P1564 ASCD STEERING SWITCH

Description

INFOID:000000005151994

ASCD steering switch has variant values of electrical resistance for each button. ECM reads voltage variation of switch, and determines which button is operated. Refer to [EC-62, "System Description"](#) for the ASCD function.

DTC Logic

INFOID:000000005151995

DTC DETECTION LOGIC

NOTE:

If DTC P1564 is displayed with DTC P0605, first perform the trouble diagnosis for DTC P0605. Refer to [EC-361, "DTC Logic"](#).

DTC No.	Trouble diagnosis name	DTC detecting condition	Possible cause
P1564	ASCD steering switch	<ul style="list-style-type: none">An excessively high voltage signal from the ASCD steering switch is sent to ECM.ECM detects that input signal from the ASCD steering switch is out of the specified range.ECM detects that the ASCD steering switch is stuck ON.	<ul style="list-style-type: none">Harness or connectors (The switch circuit is open or shorted.)ASCD steering switchECM

DTC CONFIRMATION PROCEDURE

1. PRECONDITIONING

If DTC Confirmation Procedure has been previously conducted, always perform the following procedure before conducting the next test.

- Turn ignition switch OFF and wait at least 10 seconds.
- Turn ignition switch ON.
- Turn ignition switch OFF and wait at least 10 seconds.

>> GO TO 2.

2. PERFORM DTC CONFIRMATION PROCEDURE

- Turn ignition switch ON and wait at least 10 seconds.
- Press MAIN switch for at least 10 seconds, then release it and wait at least 10 seconds.
- Press CANCEL switch for at least 10 seconds, then release it and wait at least 10 seconds.
- Press RESUME/ACCELERATE switch for at least 10 seconds, then release it and wait at least 10 seconds.
- Press SET/COAST switch for at least 10 seconds, then release it and wait at least 10 seconds.
- Check DTC.

Is DTC detected?

- YES >> Go to [EC-427, "Diagnosis Procedure"](#).
NO >> INSPECTION END

Diagnosis Procedure

INFOID:000000005151996

1. CHECK GROUND CONNECTION

- Turn ignition switch OFF.
- Check ground connection M95. Refer to Ground Inspection in [GI-39, "Circuit Inspection"](#).

Is the inspection result normal?

- YES >> GO TO 2.
NO >> Repair or replace ground connection.

2. CHECK ASCD STEERING SWITCH CIRCUIT

 With CONSULT-III

P1564 ASCD STEERING SWITCH

[VQ37VHR]

< DTC/CIRCUIT DIAGNOSIS >

1. Turn ignition switch ON.
2. Select "MAIN SW", "CANCEL SW", "RESUME/ACC SW" and "SET SW" in "DATA MONITOR" mode with CONSULT-III.
3. Check each item indication under the following conditions.

Monitor item	Condition		Indication
MAIN SW	MAIN switch	Pressed	ON
		Released	OFF
CANCEL SW	CANCEL switch	Pressed	ON
		Released	OFF
RESUME/ACC SW	RESUME/ACCELERATE switch	Pressed	ON
		Released	OFF
SET SW	SET/COAST switch	Pressed	ON
		Released	OFF

⊗ Without CONSULT-III

1. Turn ignition switch ON.
2. Check the voltage between ECM harness connector terminals as per the following.

ECM			Condition	Voltage (V)
Connector	+	-		
	Terminal	Terminal		
M107	101 (ASCD steering switch signal)	108	MAIN switch: Pressed	Approx. 0
			CANCEL switch: Pressed	Approx. 1
			SET/COAST switch: Pressed	Approx. 2
			RESUME/ACCELERATE switch: Pressed	Approx. 3
			All ASCD steering switches: Released	Approx. 4

Is the inspection result normal?

- YES >> GO TO 8.
NO >> GO TO 3.

3. CHECK ASCD STEERING SWITCH GROUND CIRCUIT FOR OPEN AND SHORT

1. Turn ignition switch OFF.
2. Disconnect ECM harness connector.
3. Disconnect combination switch harness connector M303.
4. Check the continuity between combination switch and ECM harness connector.

Combination switch	ECM		Continuity
	Terminal	Connector	
16	M107	108	Existed

5. Also check harness for short to ground and short to power.

Is the inspection result normal?

- YES >> GO TO 5.
NO >> GO TO 4.

4. DETECT MALFUNCTIONING PART

Check the following.

- Combination switch (spiral cable)
- Harness for open and short between ECM and combination switch

>> Repair open circuit, short to ground or short to power in harness or connectors.

P1564 ASCD STEERING SWITCH

< DTC/CIRCUIT DIAGNOSIS >

[VQ37VHR]

5. CHECK ASCD STEERING SWITCH INPUT SIGNAL CIRCUIT FOR OPEN AND SHORT

1. Check the continuity between combination switch and ECM harness connector.

Combination switch		ECM		Continuity
Terminal	Connector	Terminal		
13	M107	101		Existed

2. Also check harness for short to ground and short to power.

Is the inspection result normal?

YES >> GO TO 7.

NO >> GO TO 6.

6. DETECT MALFUNCTIONING PART

Check the following.

- Combination switch (spiral cable)
- Harness for open and short between ECM and combination switch

>> Repair open circuit, short to ground or short to power in harness or connectors.

7. CHECK ASCD STEERING SWITCH

Refer to [EC-429, "Component Inspection"](#).

Is the inspection result normal?

YES >> GO TO 8.

NO >> Replace ASCD steering switch.

8. CHECK INTERMITTENT INCIDENT

Refer to [GI-36, "Intermittent Incident"](#).

>> INSPECTION END

Component Inspection

INFOID:000000005151997

1. CHECK ASCD STEERING SWITCH

1. Turn ignition switch OFF.
2. Disconnect combination switch (spiral cable) harness connector M303.
3. Check resistance between combination switch harness connector terminals under the following conditions.

Combination switch		Condition	Resistance (Ω)
Connector	Terminals		
M303	13 and 16	MAIN switch: Pressed	Approx. 0
		CANCEL switch: Pressed	Approx. 250
		SET/COAST switch: Pressed	Approx. 660
		RESUME/ACCELERATE switch: Pressed	Approx. 1,480
		All ASCD steering switches: Released	Approx. 4,000

Is the inspection result normal?

YES >> INSPECTION END

NO >> Replace ASCD steering switch

P1564 ICC STEERING SWITCH

< DTC/CIRCUIT DIAGNOSIS >

[VQ37VHR]

P1564 ICC STEERING SWITCH

Description

INFOID:000000005151998

ICC steering switch has variant values of electrical resistance for each button. ECM reads voltage variation of switch, and determines which button is operated.

Refer to [CCS-17, "System Description"](#) for the ICC function.

DTC Logic

INFOID:000000005151999

DTC DETECTION LOGIC

NOTE:

If DTC P1564 is displayed with DTC P0605, first perform the trouble diagnosis for DTC P0605. Refer to [EC-361, "DTC Logic"](#).

DTC No.	Trouble diagnosis name	DTC detecting condition	Possible cause
P1564	ICC steering switch	<ul style="list-style-type: none">An excessively high voltage signal from the ICC steering switch is sent to ECM.ECM detects that input signal from the ICC steering switch is out of the specified range.ECM detects that the ICC steering switch is stuck ON.	<ul style="list-style-type: none">Harness or connectors (The switch circuit is open or shorted.)ICC steering switchECM

DTC CONFIRMATION PROCEDURE

1. PRECONDITIONING

If DTC Confirmation Procedure has been previously conducted, always perform the following procedure before conducting the next test.

- Turn ignition switch OFF and wait at least 10 seconds.
- Turn ignition switch ON.
- Turn ignition switch OFF and wait at least 10 seconds.

>> GO TO 2.

2. PERFORM DTC CONFIRMATION PROCEDURE

- Turn ignition switch ON and wait at least 10 seconds.
- Press MAIN switch for at least 10 seconds, then release it and wait at least 10 seconds.
- Press CANCEL switch for at least 10 seconds, then release it and wait at least 10 seconds.
- Press RESUME/ACCELERATE switch for at least 10 seconds, then release it and wait at least 10 seconds.
- Press SET/COAST switch for at least 10 seconds, then release it and wait at least 10 seconds.
- Press DISTANCE switch for at least 10 seconds, then release it and wait at least 10 seconds.
- Check DTC.

Is DTC detected?

- YES >> Go to [EC-430, "Diagnosis Procedure"](#).
NO >> INSPECTION END

Diagnosis Procedure

INFOID:000000005152000

1. CHECK GROUND CONNECTION

- Turn ignition switch OFF.
- Check ground connection M95. Refer to Ground Inspection in [GI-39, "Circuit Inspection"](#).

Is the inspection result normal?

- YES >> GO TO 2.
NO >> Repair or replace ground connection.

2. CHECK ICC STEERING SWITCH CIRCUIT

Ⓟ With CONSULT-III

P1564 ICC STEERING SWITCH

[VQ37VHR]

< DTC/CIRCUIT DIAGNOSIS >

1. Turn ignition switch ON.
2. Select "MAIN SW", "CANCEL SW", "RESUME/ACC SW", "SET SW" and "DIST SW" in "DATA MONITOR" mode with CONSULT-III.
3. Check each item indication under the following conditions.

Monitor item	Condition		Indication
MAIN SW	MAIN switch	Pressed	ON
		Released	OFF
CANCEL SW	CANCEL switch	Pressed	ON
		Released	OFF
RESUME/ACC SW	RESUME/ACCELERATE switch	Pressed	ON
		Released	OFF
SET SW	SET/COAST switch	Pressed	ON
		Released	OFF
DIST SW	DISTANCE switch	Pressed	ON
		Released	OFF

Without CONSULT-III

1. Turn ignition switch ON.
2. Check the voltage between ECM harness connector terminals as per the following.

Connector	ECM		Condition	Voltage (V)
	+	-		
	Terminal	Terminal		
M107	101 (ICC steering switch signal)	108	MAIN switch: Pressed	Approx. 0
			CANCEL switch: Pressed	Approx. 1.3
			DISTANCE switch: Pressed	Approx. 2.2
			SET/COAST switch: Pressed	Approx. 3.0
			RESUME/ACCELERATE switch: Pressed	Approx. 3.7
			All ICC steering switches: Released	Approx. 4.3

Is the inspection result normal?

- YES >> GO TO 8.
NO >> GO TO 3.

3. CHECK ICC STEERING SWITCH GROUND CIRCUIT FOR OPEN AND SHORT

1. Turn ignition switch OFF.
2. Disconnect ECM harness connector.
3. Disconnect combination switch harness connector M303.
4. Check the continuity between combination switch and ECM harness connector.

Combination switch	ECM		Continuity
	Terminal	Connector	
16	M107	108	Existed

5. Also check harness for short to ground and short to power.

Is the inspection result normal?

- YES >> GO TO 5.
NO >> GO TO 4.

4. DETECT MALFUNCTIONING PART

Check the following.

- Combination switch (spiral cable)
- Harness for open and short between ECM and combination switch

P1564 ICC STEERING SWITCH

< DTC/CIRCUIT DIAGNOSIS >

[VQ37VHR]

>> Repair open circuit, short to ground or short to power in harness or connectors.

5. CHECK ICC STEERING SWITCH INPUT SIGNAL CIRCUIT FOR OPEN AND SHORT

1. Check the continuity between combination switch and ECM harness connector.

Combination switch Terminal	ECM		Continuity
	Connector	Terminal	
13	M107	101	Existed

2. Also check harness for short to ground and short to power.

Is the inspection result normal?

YES >> GO TO 7.

NO >> GO TO 6.

6. DETECT MALFUNCTIONING PART

Check the following.

- Combination switch (spiral cable)
- Harness for open and short between ECM and combination switch

>> Repair open circuit, short to ground or short to power in harness or connectors.

7. CHECK ICC STEERING SWITCH

Refer to [EC-432, "Component Inspection"](#).

Is the inspection result normal?

YES >> GO TO 8.

NO >> Replace ICC steering switch.

8. CHECK INTERMITTENT INCIDENT

Refer to [GI-36, "Intermittent Incident"](#).

>> INSPECTION END

Component Inspection

INFOID:000000005152001

1. CHECK ICC STEERING SWITCH

1. Turn ignition switch OFF.
2. Disconnect combination switch (spiral cable) harness connector M303.
3. Check resistance between combination switch harness connector terminals under the following conditions.

Combination switch		Condition	Resistance (Ω)
Connector	Terminals		
M303	13 and 16	MAIN switch: Pressed	Approx. 0
		CANCEL switch: Pressed	Approx. 310
		DISTANCE switch: Pressed	Approx. 740
		SET/COAST switch: Pressed	Approx. 1,400
		RESUME/ACCELERATE switch: Pressed	Approx. 2,600
		All ICC steering switches: Released	Approx. 5,500

Is the inspection result normal?

YES >> INSPECTION END

NO >> Replace ICC steering switch

P1568 ICC FUNCTION

[VQ37VHR]

< DTC/CIRCUIT DIAGNOSIS >

P1568 ICC FUNCTION

DTC Logic

INFOID:000000005152002

DTC DETECTION LOGIC

NOTE:

- If DTC P1568 is displayed with DTC UXXXX, first perform the trouble diagnosis for DTC UXXXX.
- If DTC P1568 is displayed with DTC P0605, first perform the trouble diagnosis for DTC P0605. Refer to [EC-361, "DTC Logic"](#).
- If DTC P1568 is displayed with DTC P0607, first perform the trouble diagnosis for DTC P0607. Refer to [EC-363, "DTC Logic"](#).

DTC No.	Trouble Diagnosis Name	DTC Detecting Condition	Possible Cause
P1568	ICC function	ECM detects a difference between signals from ICC sensor integrated unit is out of specified range.	<ul style="list-style-type: none">• Harness or connectors (The CAN communication line is open or shorted.)• ICC sensor integrated unit• ECM

DTC CONFIRMATION PROCEDURE

1. PRECONDITIONING

If DTC Confirmation Procedure has been previously conducted, always perform the following procedure before conducting the next test.

1. Turn ignition switch OFF and wait at least 10 seconds.
2. Turn ignition switch ON.
3. Turn ignition switch OFF and wait at least 10 seconds.

TESTING CONDITION:

Step 4 may be conducted with the drive wheels lifted in the shop or by driving the vehicle. If a road test is expected to be easier, it is unnecessary to lift the vehicle.

>> GO TO 2.

2. PERFORM DTC CONFIRMATION PROCEDURE

1. Turn ignition switch ON.
2. Press MAIN switch on ICC steering switch.
3. Drive the vehicle at more than 40 km/h (25 MPH).

CAUTION:

Always drive vehicle at a safe speed.

4. Press SET/COAST switch.
5. Check DTC.

Is DTC detected?

- YES >> Go to [EC-433, "Diagnosis Procedure"](#).
NO >> INSPECTION END

Diagnosis Procedure

INFOID:000000005152003

1. REPLACE ICC SENSOR INTEGRATED UNIT

1. Replace ICC sensor integrated unit.
2. Perform [CCS-11, "ACTION TEST : Special Repair Requirement \(Vehicle-To-Vehicle Distance Control Mode\)"](#).
3. Check DTC of ICC sensor integrated unit. Refer to [CCS-37, "Diagnosis Description"](#).

>> INSPECTION END

P1572 ASCD BRAKE SWITCH

< DTC/CIRCUIT DIAGNOSIS >

[VQ37VHR]

P1572 ASCD BRAKE SWITCH

Description

INFOID:000000005152004

When the brake pedal is depressed, ASCD brake switch is turned OFF and stop lamp switch is turned ON. ECM detects the state of the brake pedal by those two types of input (ON/OFF signal). Refer to [EC-62. "System Description"](#) for the ASCD function.

DTC Logic

INFOID:000000005152005

DTC DETECTION LOGIC

NOTE:

- If DTC P1572 is displayed with DTC P0605, first perform the trouble diagnosis for DTC P0605. Refer to [EC-361. "DTC Logic"](#).
- This self-diagnosis has the one trip detection logic. When malfunction A is detected, DTC is not stored in ECM memory. And in that case, 1st trip DTC and 1st trip freeze frame data are displayed. 1st trip DTC is erased when ignition switch is turned OFF. And even when malfunction A is detected in two consecutive trips, DTC is not stored in ECM memory.

DTC No.	Trouble diagnosis name	DTC detecting condition		Possible cause
P1572	ASCD brake switch	A)	When the vehicle speed is above 30 km/h (19 MPH), ON signals from the stop lamp switch and the ASCD brake switch are sent to the ECM at the same time.	<ul style="list-style-type: none">• Harness or connectors (The stop lamp switch circuit is shorted.)• Harness or connectors (The ASCD brake switch circuit is shorted.)• Stop lamp switch• ASCD brake switch• Incorrect stop lamp switch installation• Incorrect ASCD brake switch installation• ECM
		B)	ASCD brake switch signal is not sent to ECM for extremely long time while the vehicle is being driven.	

DTC CONFIRMATION PROCEDURE

1. PRECONDITIONING

If DTC Confirmation Procedure has been previously conducted, always perform the following procedure before conducting the next test.

1. Turn ignition switch OFF and wait at least 10 seconds.
2. Turn ignition switch ON.
3. Turn ignition switch OFF and wait at least 10 seconds.

NOTE:

The procedure for malfunction B is not described. It takes an extremely long time to complete the procedure for malfunction B. By performing the procedure for malfunction A, the condition that causes malfunction B can be detected.

>> GO TO 2.

2. PERFORM DTC CONFIRMATION PROCEDURE FOR MALFUNCTION A

1. Start engine (VDC switch OFF).
2. Press MAIN switch and make sure that CRUISE lamp illuminates.
3. Drive the vehicle for at least 5 consecutive seconds under the following conditions.

CAUTION:

Always drive vehicle at a safe speed.

NOTE:

This procedure may be conducted with the drive wheels lifted in the shop or by driving the vehicle. If a road test is expected to be easier, it is unnecessary to lift the vehicle.

Vehicle speed	More than 30 km/h (19 mph)
Selector lever	Suitable position

4. Check 1st trip DTC.

P1572 ASCD BRAKE SWITCH

[VQ37VHR]

< DTC/CIRCUIT DIAGNOSIS >

Is 1st trip DTC detected?

- YES >> Go to [EC-435, "Diagnosis Procedure"](#).
- NO >> GO TO 3.

3.PERFORM DTC CONFIRMATION PROCEDURE

1. Drive the vehicle for at least 5 consecutive seconds under the following conditions.

CAUTION:

Always drive vehicle at a safe speed.

NOTE:

This procedure may be conducted with the drive wheels lifted in the shop or by driving the vehicle. If a road test is expected to be easier, it is unnecessary to lift the vehicle.

Vehicle speed	More than 30 km/h (19 mph)
Selector lever	Suitable position
Driving location	Depress the brake pedal for more than 5 seconds so as not to come off from the above-mentioned vehicle speed.

2. Check 1st trip DTC.

Is 1st trip DTC detected?

- YES >> Go to [EC-435, "Diagnosis Procedure"](#).
- NO >> INSPECTION END

Diagnosis Procedure

INFOID:000000005152006

1.CHECK OVERALL FUNCTION-I

 **With CONSULT-III**

1. Turn ignition switch ON.
2. Select "BRAKE SW1" in "DATA MONITOR" mode with CONSULT-III.
3. Check "BRAKE SW1" indication under the following conditions.

Monitor item	Condition		Indication
BRAKE SW1	Brake pedal (A/T) Brake pedal or clutch pedal (M/T)	Slightly depressed	OFF
	Brake pedal (A/T) Brake pedal and clutch pedal (M/T)	Fully released	ON

 **Without CONSULT-III**

1. Turn ignition switch ON.
2. Check the voltage between ECM harness connector terminals as per the following.

Connector	ECM		Condition	Voltage (V)	
	+	-			
	Terminal	Terminal			
M107	126 (ASCD brake switch signal)	128	Brake pedal (A/T) Brake pedal or clutch pedal (M/T)	Slightly depressed	Approx. 0
			Brake pedal (A/T) Brake pedal and clutch pedal (M/T)	Fully released	Battery voltage

Is the inspection result normal?

- YES >> GO TO 2.
- NO-1 >> A/T models: GO TO 3.
- NO-2 >> M/T models: GO TO 8.

2.CHECK OVERALL FUNCTION-II

 **With CONSULT-III**

Select "BRAKE SW2" and check indication under the following conditions.

P1572 ASCD BRAKE SWITCH

[VQ37VHR]

< DTC/CIRCUIT DIAGNOSIS >

Monitor item	Condition		Indication
BRAKE SW2	Brake pedal	Slightly depressed	ON
		Fully released	OFF

⊗ Without CONSULT-III

Check the voltage between ECM harness connector terminals as per the following.

Connector	ECM		Condition	Voltage (V)
	+	-		
	Terminal	Terminal		
M107	122 (Stop lamp switch signal)	128	Brake pedal Slightly depressed	Battery voltage
			Fully released	Approx. 0

Is the inspection result normal?

YES >> GO TO 21.

NO >> GO TO 16.

3. CHECK ASCD BRAKE SWITCH POWER SUPPLY CIRCUIT

1. Turn ignition switch OFF.
2. Disconnect ASCD brake switch harness connector.
3. Turn ignition switch ON.
4. Check the voltage between ASCD brake switch harness connector and ground.

ASCD brake switch		Ground	Voltage
Connector	Terminal		
E109	1	Ground	Battery voltage

Is the inspection result normal?

YES >> GO TO 5.

NO >> GO TO 4.

4. DETECT MALFUNCTIONING PART

Check the following.

- Fuse block (J/B) connector E103
- 10 A fuse (No. 3)
- Harness for open or short between ASCD brake switch and fuse

>> Repair open circuit or short to ground in harness or connectors.

5. CHECK ASCD BRAKE SWITCH INPUT SIGNAL CIRCUIT FOR OPEN AND SHORT

1. Turn ignition switch OFF.
2. Disconnect ECM harness connector.
3. Check the continuity between ASCD brake switch harness connector and ECM harness connector.

ASCD brake switch		ECM		Continuity
Connector	Terminal	Connector	Terminal	
E109	2	M107	126	Existed

4. Also check harness for short to ground and short to power.

Is the inspection result normal?

YES >> GO TO 7.

NO >> GO TO 6.

6. DETECT MALFUNCTIONING PART

Check the following.

- Harness connectors E106, M6

P1572 ASCD BRAKE SWITCH

[VQ37VHR]

< DTC/CIRCUIT DIAGNOSIS >

- Harness for open or short between ECM and ASCD brake switch

>> Repair open circuit, short to ground or short to power in harness or connectors.

7. CHECK ASCD BRAKE SWITCH

Refer to [EC-439. "Component Inspection \(ASCD Brake Switch\)"](#)

Is the inspection result normal?

YES >> GO TO 21.

NO >> Replace ASCD brake switch.

8. CHECK ASCD CLUTCH SWITCH CIRCUIT

1. Turn ignition switch OFF.
2. Disconnect ASCD brake switch harness connector.
3. Turn ignition switch ON.
4. Check the voltage between ASCD brake switch harness connector and ground.

ASCD brake switch		Ground	Condition	Voltage (V)	
Connector	Terminal				
E109	1	Ground	Clutch pedal	Slightly depressed	Approx. 0
				Fully released	Battery voltage

Is the inspection result normal?

YES >> GO TO 13.

NO >> GO TO 9.

9. CHECK ASCD CLUTCH SWITCH POWER SUPPLY CIRCUIT

1. Turn ignition switch OFF.
2. Disconnect ASCD clutch switch harness connector.
3. Turn ignition switch ON.
4. Check the voltage between ASCD clutch switch harness connector and ground.

ASCD clutch switch		Ground	Voltage
Connector	Terminal		
E108	1	Ground	Battery voltage

Is the inspection result normal?

YES >> GO TO 11.

NO >> GO TO 10.

10. DETECT MALFUNCTIONING PART

Check the following.

- Fuse block (J/B) connector E103
- 10 A fuse (No. 3)
- Harness for open or short between ASCD clutch switch and fuse

>> Repair open circuit or short to ground in harness or connectors.

11. CHECK ASCD BRAKE SWITCH INPUT SIGNAL CIRCUIT FOR OPEN AND SHORT-I

1. Turn ignition switch OFF.
2. Check the continuity between ASCD clutch switch harness connector and ASCD brake switch harness connector.

ASCD clutch switch		ASCD brake switch		Continuity
Connector	Terminal	Connector	Terminal	
E108	2	E109	1	Existed

3. Also check harness for short to ground and short to power.

P1572 ASCD BRAKE SWITCH

[VQ37VHR]

< DTC/CIRCUIT DIAGNOSIS >

Is the inspection result normal?

YES >> GO TO 12.

NO >> Repair open circuit, short to ground or short to power in harness or connectors.

12.CHECK ASCD CLUTCH SWITCH

Refer to [EC-440. "Component Inspection \(ASCD Clutch Switch\)".](#)

Is the inspection result normal?

YES >> GO TO 21.

NO >> Replace ASCD clutch switch.

13.CHECK ASCD BRAKE SWITCH INPUT SIGNAL CIRCUIT FOR OPEN AND SHORT-II

1. Turn ignition switch OFF.
2. Disconnect ECM harness connector.
3. Check the continuity between ASCD brake switch harness connector and ECM harness connector.

ASCD brake switch		ECM		Continuity
Connector	Terminal	Connector	Terminal	
E109	2	M107	126	Existed

4. Also check harness for short to ground and short to power.

Is the inspection result normal?

YES >> GO TO 15.

NO >> GO TO 14.

14.DETECT MALFUNCTIONING PART

Check the following.

- Harness connectors E106, M6
- Harness for open or short between ECM and ASCD brake switch

>> Repair open circuit, short to ground or short to power in harness or connectors.

15.CHECK ASCD BRAKE SWITCH

Refer to [EC-439. "Component Inspection \(ASCD Brake Switch\)".](#)

Is the inspection result normal?

YES >> GO TO 21.

NO >> Replace ASCD brake switch.

16.CHECK STOP LAMP SWITCH POWER SUPPLY CIRCUIT

1. Turn ignition switch OFF.
2. Disconnect stop lamp switch harness connector.
3. Check the voltage between stop lamp switch harness connector and ground.

Stop lamp switch		Ground	Voltage
Connector	Terminal		
E110	3	Ground	Battery voltage

Is the inspection result normal?

YES >> GO TO 18.

NO >> GO TO 17.

17.DETECT MALFUNCTIONING PART

Check the following.

- Fuse block (J/B) connector E103
- 10A fuse (No. 7)
- Harness for open or short between stop lamp switch and battery

>> Repair open circuit, short to ground or short to power in harness or connectors.

P1572 ASCD BRAKE SWITCH

< DTC/CIRCUIT DIAGNOSIS >

[VQ37VHR]

18. CHECK STOP LAMP SWITCH INPUT SIGNAL CIRCUIT FOR OPEN AND SHORT

1. Disconnect ECM harness connector.
2. Check the continuity between stop lamp switch harness connector and ECM harness connector.

Stop lamp switch		ECM		Continuity
Connector	Terminal	Connector	Terminal	
E110	4	M107	122	Existed

3. Also check harness for short to ground and short to power.

Is the inspection result normal?

- YES >> GO TO 20.
NO >> GO TO 19.

19. DETECT MALFUNCTIONING PART

Check the following.

- Fuse block (J/B) connectors E103, M2
- Harness for open or short between ECM and stop lamp switch

>> Repair open circuit, short to ground or short to power in harness or connectors.

20. CHECK STOP LAMP SWITCH

Refer to [EC-440. "Component Inspection \(Stop Lamp Switch\)"](#)

Is the inspection result normal?

- YES >> GO TO 21.
NO >> Replace stop lamp switch.

21. CHECK INTERMITTENT INCIDENT

Refer to [GI-36. "Intermittent Incident"](#).

>> INSPECTION END

Component Inspection (ASCD Brake Switch)

INFOID:000000005152007

1. CHECK ASCD BRAKE SWITCH-I

1. Turn ignition switch OFF.
2. Disconnect ASCD brake switch harness connector.
3. Check the continuity between ASCD brake switch terminals under the following conditions.

Terminals	Condition		Continuity
1 and 2	Brake pedal	Fully released	Existed
		Slightly depressed	Not existed

Is the inspection result normal?

- YES >> INSPECTION END
NO >> GO TO 2.

2. CHECK ASCD BRAKE SWITCH-II

1. Adjust ASCD brake switch installation. Refer to [BR-8. "Inspection and Adjustment"](#).
2. Check the continuity between ASCD brake switch terminals under the following conditions.

Terminals	Condition		Continuity
1 and 2	Brake pedal	Fully released	Existed
		Slightly depressed	Not existed

Is the inspection result normal?

P1572 ASCD BRAKE SWITCH

[VQ37VHR]

< DTC/CIRCUIT DIAGNOSIS >

- YES >> INSPECTION END
NO >> Replace ASCD brake switch.

Component Inspection (ASCD Clutch Switch)

INFOID:000000005152008

1.CHECK ASCD CLUTCH SWITCH-I

1. Turn ignition switch OFF.
2. Disconnect ASCD clutch switch harness connector.
3. Check the continuity between ASCD clutch switch terminals under the following conditions.

Terminals	Condition		Continuity
1 and 2	Clutch pedal	Fully released	Existed
		Slightly depressed	Not existed

Is the inspection result normal?

- YES >> INSPECTION END
NO >> GO TO 2.

2.CHECK ASCD CLUTCH SWITCH-II

1. Adjust ASCD clutch switch installation. Refer to [BR-8. "Inspection and Adjustment"](#).
2. Check the continuity between ASCD clutch switch terminals under the following conditions.

Terminals	Condition		Continuity
1 and 2	Clutch pedal	Fully released	Existed
		Slightly depressed	Not existed

Is the inspection result normal?

- YES >> INSPECTION END
NO >> Replace ASCD clutch switch.

Component Inspection (Stop Lamp Switch)

INFOID:000000005152009

1.CHECK STOP LAMP SWITCH-I

1. Turn ignition switch OFF.
2. Disconnect stop lamp switch harness connector.
3. Check the continuity between stop lamp switch terminals under the following conditions.

Terminals	Condition		Continuity
3 and 4	Brake pedal	Fully released	Not existed
		Slightly depressed	Existed

Is the inspection result normal?

- YES >> INSPECTION END
NO >> GO TO 2.

2.CHECK STOP LAMP SWITCH-II

1. Adjust stop lamp switch installation. Refer to [BR-8. "Inspection and Adjustment"](#).
2. Check the continuity between stop lamp switch terminals under the following conditions.

Terminals	Condition		Continuity
3 and 4	Brake pedal	Fully released	Not existed
		Slightly depressed	Existed

Is the inspection result normal?

- YES >> INSPECTION END
NO >> Replace stop lamp switch.

P1572 ICC BRAKE SWITCH

< DTC/CIRCUIT DIAGNOSIS >

[VQ37VHR]

P1572 ICC BRAKE SWITCH

Description

INFOID:000000005152010

When the brake pedal is depressed, ICC brake switch is turned OFF and stop lamp switch is turned ON. ECM detects the state of the brake pedal by those two types of input (ON/OFF signal). Refer to [CCS-17, "System Description"](#) for the ICC function.

DTC Logic

INFOID:000000005152011

DTC DETECTION LOGIC

NOTE:

- If DTC P1572 is displayed with DTC P0605, first perform the trouble diagnosis for DTC P0605. Refer to [EC-361, "DTC Logic"](#).
- This self-diagnosis has the one trip detection logic. When malfunction A is detected, DTC is not stored in ECM memory. And in that case, 1st trip DTC and 1st trip freeze frame data are displayed. 1st trip DTC is erased when ignition switch is turned OFF. And even when malfunction A is detected in two consecutive trips, DTC is not stored in ECM memory.

DTC No.	Trouble diagnosis name	DTC detecting condition		Possible cause
P1572	ICC brake switch	A)	ON signals from the stop lamp switch and the ICC brake switch are sent to ECM at the same time.	<ul style="list-style-type: none">• Harness or connectors (The stop lamp switch circuit is shorted.)• Harness or connectors (The ICC brake switch circuit is shorted.)• Stop lamp switch• ICC brake switch• ICC brake hold relay• Incorrect stop lamp switch installation• Incorrect ICC brake switch installation• ECM
		B)	ICC brake switch signal is not sent to ECM for extremely long time while the vehicle is being driven	

DTC CONFIRMATION PROCEDURE

1. PRECONDITIONING

If DTC Confirmation Procedure has been previously conducted, always perform the following procedure before conducting the next test.

1. Turn ignition switch OFF and wait at least 10 seconds.
2. Turn ignition switch ON.
3. Turn ignition switch OFF and wait at least 10 seconds.

NOTE:

The procedure for malfunction B is not described. It takes an extremely long time to complete the procedure for malfunction B. By performing the procedure for malfunction A, the condition that causes malfunction B can be detected.

>> GO TO 2.

2. PERFORM DTC CONFIRMATION PROCEDURE

1. Start engine (VDC switch OFF).
2. Press MAIN switch and make sure that CRUISE lamp illuminates.
3. Drive the vehicle for at least 5 consecutive seconds under the following conditions.

CAUTION:

Always drive vehicle at a safe speed.

NOTE:

This procedure may be conducted with the drive wheels lifted in the shop or by driving the vehicle. If a road test is expected to be easier, it is unnecessary to lift the vehicle.

Vehicle speed	More than 30 km/h (19 mph)
Selector lever	Suitable position

4. Check 1st trip DTC.

P1572 ICC BRAKE SWITCH

[VQ37VHR]

< DTC/CIRCUIT DIAGNOSIS >

Is 1st trip DTC detected?

- YES >> Go to [EC-442, "Diagnosis Procedure"](#).
- NO >> GO TO 3.

3.PERFORM DTC CONFIRMATION PROCEDURE

1. Drive the vehicle for at least 5 consecutive seconds under the following conditions.

CAUTION:

Always drive vehicle at a safe speed.

NOTE:

This procedure may be conducted with the drive wheels lifted in the shop or by driving the vehicle. If a road test is expected to be easier, it is unnecessary to lift the vehicle.

Vehicle speed	More than 30 km/h (19 mph)
Selector lever	Suitable position
Driving location	Depress the brake pedal for more than 5 seconds so as not to come off from the above-mentioned vehicle speed.

2. Check 1st trip DTC.

Is 1st trip DTC detected?

- YES >> Go to [EC-442, "Diagnosis Procedure"](#).
- NO >> INSPECTION END

Diagnosis Procedure

INFOID:000000005152012

1.CHECK OVERALL FUNCTION-I

☑ With CONSULT-III

1. Turn ignition switch ON.
2. Select "BRAKE SW1" in "DATA MONITOR" mode with CONSULT-III.
3. Check "BRAKE SW1" indication under the following conditions.

Monitor item	Condition		Indication
BRAKE SW1	Brake pedal (A/T) Brake pedal or clutch pedal (M/T)	Slightly depressed	OFF
	Brake pedal (A/T) Brake pedal and clutch pedal (M/T)	Fully released	ON

☒ Without CONSULT-III

1. Turn ignition switch ON.
2. Check the voltage between ECM harness connector terminals under the following conditions.

Connector	ECM		Condition	Voltage (V)	
	+	-			
	Terminal	Terminal			
M107	126 (ICC brake switch signal)	128	Brake pedal (A/T) Brake pedal or clutch pedal (M/T)	Slightly depressed	Approx. 0
			Brake pedal (A/T) Brake pedal and clutch pedal (M/T)	Fully released	Battery voltage

Is the inspection result normal?

- YES >> GO TO 2.
- NO-1 >> A/T models: GO TO 3.
- NO-2 >> M/T models: GO TO 8.

2.CHECK OVERALL FUNCTION-II

☑ With CONSULT-III

Select "BRAKE SW2" and check indication under the following conditions.

P1572 ICC BRAKE SWITCH

[VQ37VHR]

< DTC/CIRCUIT DIAGNOSIS >

Monitor item	Condition		Indication
BRAKE SW2	Brake pedal	Slightly depressed	ON
		Fully released	OFF

⊗ Without CONSULT-III

Check the voltage between ECM harness connector terminals as per the following.

Connector	ECM		Condition	Voltage (V)
	+	-		
	Terminal	Terminal		
M107	122 (Stop lamp switch signal)	128	Brake pedal Slightly depressed	Battery voltage
			Fully released	Approx. 0

Is the inspection result normal?

YES >> GO TO 22.

NO >> GO TO 16.

3. CHECK ICC BRAKE SWITCH POWER SUPPLY CIRCUIT

1. Turn ignition switch OFF.
2. Disconnect ICC brake switch harness connector.
3. Turn ignition switch ON.
4. Check the voltage between ICC brake switch harness connector and ground.

ICC brake switch		Ground	Voltage
Connector	Terminal		
E114	1	Ground	Battery voltage

Is the inspection result normal?

YES >> GO TO 5.

NO >> GO TO 4.

4. DETECT MALFUNCTIONING PART

Check the following.

- Fuse block (J/B) connector E103
- 10 A fuse (No. 3)
- Harness for open or short between ICC brake switch and fuse

>> Repair open circuit or short to ground in harness or connectors.

5. CHECK ICC BRAKE SWITCH INPUT SIGNAL CIRCUIT FOR OPEN AND SHORT

1. Turn ignition switch OFF.
2. Disconnect ECM harness connector.
3. Check the continuity between ICC brake switch harness connector and ECM harness connector.

ICC brake switch		ECM		Continuity
Connector	Terminal	Connector	Terminal	
E114	2	M107	126	Existed

4. Also check harness for short to ground and short to power.

Is the inspection result normal?

YES >> GO TO 7.

NO >> GO TO 6.

6. DETECT MALFUNCTIONING PART

Check the following.

A
EC

C
D
E

F

G

H

I

J

K

L

M

N

O

P

P1572 ICC BRAKE SWITCH

[VQ37VHR]

< DTC/CIRCUIT DIAGNOSIS >

- Harness connectors E106, M6
- Harness for open or short between ICC brake switch and ECM

>> Repair open circuit, short to ground or short to power in harness or connectors.

7. CHECK ICC BRAKE SWITCH

Refer to [EC-446, "Component Inspection \(ICC Brake Switch\)"](#).

Is the inspection result normal?

YES >> GO TO 22.

NO >> Replace ICC brake switch.

8. CHECK ICC CLUTCH SWITCH CIRCUIT

1. Turn ignition switch OFF.
2. Disconnect ICC brake switch harness connector.
3. Turn ignition switch ON.
4. Check the voltage between ICC brake switch harness connector and ground.

ICC brake switch		Ground	Condition	Voltage (V)	
Connector	Terminal				
E114	1	Ground	Clutch pedal	Slightly depressed	Approx. 0
				Fully released	Battery voltage

Is the inspection result normal?

YES >> GO TO 13.

NO >> GO TO 9.

9. CHECK ICC CLUTCH SWITCH POWER SUPPLY CIRCUIT

1. Turn ignition switch OFF.
2. Disconnect ICC clutch switch harness connector.
3. Turn ignition switch ON.
4. Check the voltage between ICC clutch switch harness connector and ground.

ICC clutch switch		Ground	Voltage
Connector	Terminal		
E113	1	Ground	Battery voltage

Is the inspection result normal?

YES >> GO TO 11.

NO >> GO TO 10.

10. DETECT MALFUNCTIONING PART

Check the following.

- Fuse block (J/B) connector E103
- 10 A fuse (No. 3)
- Harness for open or short between ICC clutch switch and fuse

>> Repair open circuit or short to ground in harness or connectors.

11. CHECK ICC BRAKE SWITCH INPUT SIGNAL CIRCUIT FOR OPEN AND SHORT-I

1. Turn ignition switch OFF.
2. Check the continuity between ICC clutch switch harness connector and ICC brake switch harness connector.

ICC clutch switch		ICC brake switch		Continuity
Connector	Terminal	Connector	Terminal	
E113	2	E114	1	Existed

P1572 ICC BRAKE SWITCH

[VQ37VHR]

< DTC/CIRCUIT DIAGNOSIS >

3. Also check harness for short to ground and short to power.

Is the inspection result normal?

YES >> GO TO 12.

NO >> Repair open circuit, short to ground or short to power in harness or connectors.

12.CHECK ICC CLUTCH SWITCH

Refer to [EC-447, "Component Inspection \(ICC Clutch Switch\)"](#).

Is the inspection result normal?

YES >> GO TO 22.

NO >> Replace ICC clutch switch.

13.CHECK ICC BRAKE SWITCH INPUT SIGNAL CIRCUIT FOR OPEN AND SHORT-II

1. Turn ignition switch OFF.

2. Disconnect ECM harness connector.

3. Check the continuity between ICC brake switch harness connector and ECM harness connector.

ICC brake switch		ECM		Continuity
Connector	Terminal	Connector	Terminal	
E114	2	M107	126	Existed

4. Also check harness for short to ground and short to power.

Is the inspection result normal?

YES >> GO TO 15.

NO >> GO TO 14.

14.DETECT MALFUNCTIONING PART

Check the following.

- Harness connectors E106, M6
- Harness for open or short between ICC brake switch and ECM

>> Repair open circuit, short to ground or short to power in harness or connectors.

15.CHECK ICC BRAKE SWITCH

Refer to [EC-446, "Component Inspection \(ICC Brake Switch\)"](#).

Is the inspection result normal?

YES >> GO TO 22.

NO >> Replace ICC brake switch.

16.CHECK STOP LAMP SWITCH POWER SUPPLY CIRCUIT

1. Turn ignition switch OFF.

2. Disconnect stop lamp switch harness connector.

3. Disconnect ICC brake hold relay harness connector.

4. Check the voltage between stop lamp switch harness connector and ground.

Stop lamp switch		Ground	Voltage
Connector	Terminal		
E110	3	Ground	Battery voltage

5. Check the voltage between ICC brake hold relay harness connector and ground.

ICC brake hold relay		Ground	Voltage
Connector	Terminal		
E51	3	Ground	Battery voltage

Is the inspection result normal?

YES >> GO TO 18.

NO >> GO TO 17.

17.DETECT MALFUNCTIONING PART

Check the following.

- Fuse block (J/B) connector E103
- 10 A fuse (No. 7)
- Harness for open or short between battery and stop lamp switch
- Harness for open or short between battery and ICC brake hold relay

>> Repair open circuit or short to ground in harness or connectors.

18.CHECK STOP LAMP SWITCH INPUT SIGNAL CIRCUIT FOR OPEN AND SHORT

1. Disconnect ECM harness connector.
2. Check the continuity between stop lamp switch harness connector and ECM harness connector.

Stop lamp switch		ECM		Continuity
Connector	Terminal	Connector	Terminal	
E110	4	M107	122	Existed

3. Check the continuity between ICC brake hold relay harness connector and ECM harness connector.

ICC brake hold relay		ECM		Continuity
Connector	Terminal	Connector	Terminal	
E51	5	M107	122	Existed

4. Also check harness for short to ground and short to power.

Is the inspection result normal?

- YES >> GO TO 20.
- NO >> GO TO 19.

19.DETECT MALFUNCTIONING PART

Check the following.

- Fuse block (J/B) connector E103, M2
- Harness for open or short between ECM and stop lamp switch
- Harness for open or short between ECM and ICC brake hold relay

>> Repair open circuit, short to ground or short to power in harness or connectors.

20.CHECK STOP LAMP SWITCH

Refer to [EC-447, "Component Inspection \(Stop Lamp Switch\)".](#)

Is the inspection result normal?

- YES >> GO TO 21.
- NO >> Replace stop lamp switch.

21.CHECK ICC BRAKE HOLD RELAY

Refer to [EC-448, "Component Inspection \(ICC Brake Hold Relay\)".](#)

Is the inspection result normal?

- YES >> GO TO 22.
- NO >> Replace ICC brake hold relay.

22.CHECK INTERMITTENT INCIDENT

Refer to [GI-36, "Intermittent Incident".](#)

>> INSPECTION END

Component Inspection (ICC Brake Switch)

INFOID:000000005152013

1.CHECK ICC BRAKE SWITCH-I

P1572 ICC BRAKE SWITCH

[VQ37VHR]

< DTC/CIRCUIT DIAGNOSIS >

1. Turn ignition switch OFF.
2. Disconnect ICC brake switch harness connector.
3. Check the continuity between ICC brake switch terminals under the following conditions.

Terminals	Condition		Continuity
1 and 2	Brake pedal	Fully released	Existed
		Slightly depressed	Not existed

Is the inspection result normal?

YES >> INSPECTION END

NO >> GO TO 2.

2.CHECK ICC BRAKE SWITCH-II

1. Adjust ICC brake switch installation. Refer to [BR-8. "Inspection and Adjustment"](#).
2. Check the continuity between ICC brake switch terminals under the following conditions.

Terminals	Condition		Continuity
1 and 2	Brake pedal	Fully released	Existed
		Slightly depressed	Not existed

Is the inspection result normal?

YES >> INSPECTION END

NO >> Replace ICC brake switch.

Component Inspection (ICC Clutch Switch)

INFOID:000000005152014

1.CHECK ICC CLUTCH SWITCH-I

1. Turn ignition switch OFF.
2. Disconnect ICC clutch switch harness connector.
3. Check the continuity between ICC clutch switch terminals under the following conditions.

Terminals	Condition		Continuity
1 and 2	Clutch pedal	Fully released	Existed
		Slightly depressed	Not existed

Is the inspection result normal?

YES >> INSPECTION END

NO >> GO TO 2.

2.CHECK ICC CLUTCH SWITCH-II

1. Adjust ICC clutch switch installation. Refer to [BR-8. "Inspection and Adjustment"](#).
2. Check the continuity between ICC clutch switch terminals under the following conditions.

Terminals	Condition		Continuity
1 and 2	Clutch pedal	Fully released	Existed
		Slightly depressed	Not existed

Is the inspection result normal?

YES >> INSPECTION END

NO >> Replace ICC clutch switch.

Component Inspection (Stop Lamp Switch)

INFOID:000000005152015

1.CHECK STOP LAMP SWITCH-I

1. Turn ignition switch OFF.
2. Disconnect stop lamp switch harness connector.
3. Check the continuity between stop lamp switch terminals under the following conditions.

P1572 ICC BRAKE SWITCH

[VQ37VHR]

< DTC/CIRCUIT DIAGNOSIS >

Terminals	Condition		Continuity
3 and 4	Brake pedal	Fully released	Not existed
		Slightly depressed	Existed

Is the inspection result normal?

YES >> INSPECTION END

NO >> GO TO 2.

2.CHECK STOP LAMP SWITCH-II

- Adjust stop lamp switch installation. Refer to [BR-8, "Inspection and Adjustment"](#).
- Check the continuity between stop lamp switch terminals under the following conditions.

Terminals	Condition		Continuity
3 and 4	Brake pedal	Fully released	Not existed
		Slightly depressed	Existed

Is the inspection result normal?

YES >> INSPECTION END

NO >> Replace stop lamp switch.

Component Inspection (ICC Brake Hold Relay)

INFOID:000000005152016

1.CHECK ICC BRAKE HOLD RELAY

- Turn ignition switch OFF.
- Remove ICC brake hold relay.
- Check the continuity between ICC brake hold relay terminals under the following conditions.

Terminals	Condition	Continuity
3 and 5	12V direct current supply between terminals 1 and 2	Existed
	No current supply	Not existed

Is the inspection result normal?

YES >> INSPECTION END

NO >> Replace ICC brake hold relay

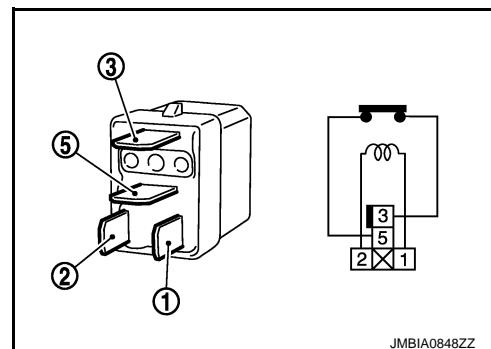

JMBIA0848ZZ

P1574 ASCD VEHICLE SPEED SENSOR

< DTC/CIRCUIT DIAGNOSIS >

[VQ37VHR]

P1574 ASCD VEHICLE SPEED SENSOR

Description

INFOID:000000005152017

The ECM receives two vehicle speed signals via the CAN communication line. One is sent from “unified meter and A/C amp.”, and the other is from TCM (Transmission control module). The ECM uses these signals for ASCD control. Refer to [EC-62, "System Description"](#) for ASCD functions.

DTC Logic

INFOID:000000005152018

DTC DETECTION LOGIC

NOTE:

- If DTC P1574 is displayed with DTC UXXXX, first perform the trouble diagnosis for DTC UXXXX.
- If DTC P1574 is displayed with DTC P0500, first perform the trouble diagnosis for DTC P0500. Refer to [EC-342, "DTC Logic"](#).
- If DTC P1574 is displayed with DTC P0605, first perform the trouble diagnosis for DTC P0605. Refer to [EC-361, "DTC Logic"](#).
- If DTC P1574 is displayed with DTC P0607, first perform the trouble diagnosis for DTC P0607. Refer to [EC-363, "DTC Logic"](#).

DTC No.	Trouble diagnosis name	DTC detecting condition	Possible cause
P1574	ASCD vehicle speed sensor	The difference between the two vehicle speed signals is out of the specified range.	<ul style="list-style-type: none">• Harness or connectors (The CAN communication line is open or shorted.)• Unified meter and A/C amp.• ABS actuator and electric unit (control unit)• Wheel sensor• TCM• ECM

DTC CONFIRMATION PROCEDURE

1. PRECONDITIONING

If DTC Confirmation Procedure has been previously conducted, always perform the following procedure before conducting the next test.

1. Turn ignition switch OFF and wait at least 10 seconds.
2. Turn ignition switch ON.
3. Turn ignition switch OFF and wait at least 10 seconds.

>> GO TO 2.

2. PERFORM DTC CONFIRMATION PROCEDURE

1. Start engine (VDC switch OFF).
2. Drive the vehicle at more than 40 km/h (25 MPH).

CAUTION:

Always drive vehicle at a safe speed.

NOTE:

This procedure may be conducted with the drive wheels lifted in the shop or by driving the vehicle. If a road test is expected to be easier, it is unnecessary to lift the vehicle.

3. Check DTC.

Is DTC detected?

- YES >> Go to [EC-449, "Diagnosis Procedure"](#).
NO >> INSPECTION END

Diagnosis Procedure

INFOID:000000005152019

1. CHECK DTC WITH TCM

Check DTC with TCM. Refer to [TM-150, "Diagnosis Description"](#).

Is the inspection result normal?

P1574 ASCD VEHICLE SPEED SENSOR

[VQ37VHR]

< DTC/CIRCUIT DIAGNOSIS >

- YES >> GO TO 2.
- NO >> Perform trouble shooting relevant to DTC indicated.

2.CHECK DTC WITH "ABS ACTUATOR AND ELECTRIC UNIT (CONTROL UNIT)"

Refer to [BRC-27. "CONSULT-III Function"](#).

Is the inspection result normal?

- YES >> GO TO 3.
- NO >> Repair or replace.

3.CHECK DTC WITH "UNIFIED METER AND A/C AMP."

Refer to [MWI-37. "CONSULT-III Function \(METER/M&A\)"](#).

>> INSPECTION END

P1574 ICC VEHICLE SPEED SENSOR

< DTC/CIRCUIT DIAGNOSIS >

[VQ37VHR]

P1574 ICC VEHICLE SPEED SENSOR

Description

INFOID:000000005152020

The ECM receives two vehicle speed signals via CAN communication line. One is sent from “unified meter and A/C amp.”, and the other is from TCM (Transmission control module). The ECM uses these signals for ICC control. Refer to [CCS-17, "System Description"](#) for ICC functions.

DTC Logic

INFOID:000000005152021

DTC DETECTION LOGIC

NOTE:

- If DTC P1574 is displayed with DTC UXXXX, first perform the trouble diagnosis for DTC UXXXX.
- If DTC P1574 is displayed with DTC P0500, first perform the trouble diagnosis for DTC P0500. Refer to [EC-342, "DTC Logic"](#).
- If DTC P1574 is displayed with DTC P0605, first perform the trouble diagnosis for DTC P0605. Refer to [EC-361, "DTC Logic"](#).
- If DTC P1574 is displayed with DTC P0607, first perform the trouble diagnosis for DTC P0607. Refer to [EC-363, "DTC Logic"](#).

DTC No.	Trouble diagnosis name	DTC detecting condition	Possible cause
P1574	ICC vehicle speed sensor	The difference between the two vehicle speed signals is out of the specified range.	<ul style="list-style-type: none">• Harness or connectors (The CAN communication line is open or shorted.)• Unified meter and A/C amp.• ABS actuator and electric unit (control unit)• Wheel sensor• TCM• ECM

DTC CONFIRMATION PROCEDURE

1. PRECONDITIONING

If DTC Confirmation Procedure has been previously conducted, always perform the following procedure before conducting the next test.

1. Turn ignition switch OFF and wait at least 10 seconds.
2. Turn ignition switch ON.
3. Turn ignition switch OFF and wait at least 10 seconds.

>> GO TO 2.

2. PERFORM DTC CONFIRMATION PROCEDURE

1. Start engine (VDC switch OFF).
2. Drive the vehicle at more than 40 km/h (25 MPH).

CAUTION:

Always drive vehicle at a safe speed.

NOTE:

This procedure may be conducted with the drive wheels lifted in the shop or by driving the vehicle. If a road test is expected to be easier, it is unnecessary to lift the vehicle.

3. Check DTC.

Is DTC detected?

- YES >> Go to [EC-451, "Diagnosis Procedure"](#).
NO >> INSPECTION END

Diagnosis Procedure

INFOID:000000005152022

1. CHECK DTC WITH TCM

Check DTC with TCM. Refer to [TM-150, "Diagnosis Description"](#).

Is the inspection result normal?

P1574 ICC VEHICLE SPEED SENSOR

[VQ37VHR]

< DTC/CIRCUIT DIAGNOSIS >

YES >> GO TO 2.

NO >> Perform trouble shooting relevant to DTC indicated.

2.CHECK DTC WITH "ABS ACTUATOR AND ELECTRIC UNIT (CONTROL UNIT)"

Refer to [BRC-27, "CONSULT-III Function"](#).

Is the inspection result normal?

YES >> GO TO 3.

NO >> Repair or replace.

3.CHECK DTC WITH "UNIFIED METER AND A/C AMP."

Check combination meter function.

Refer to [MWI-37, "CONSULT-III Function \(METER/M&A\)"](#).

>> INSPECTION END

P1606 VVEL CONTROL MODULE

< DTC/CIRCUIT DIAGNOSIS >

[VQ37VHR]

P1606 VVEL CONTROL MODULE

Description

INFOID:000000005152023

The VVEL control module consists of a microcomputer and connectors for signal input and output and for power supply. The VVEL control module controls VVEL system.

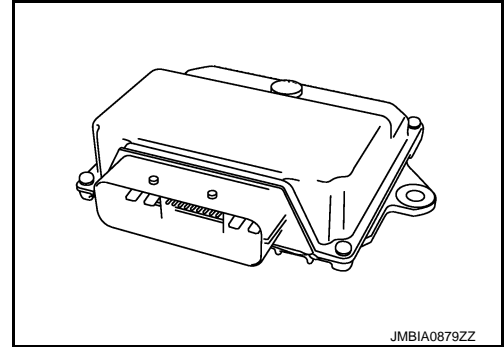

DTC Logic

INFOID:000000005152024

DTC DETECTION LOGIC

DTC No.	Trouble diagnosis name	DTC detecting condition	Possible cause
P1606	VVEL control module	<ul style="list-style-type: none">• VVEL control module calculation function is malfunctioning.• VVEL EEP-ROM system is malfunctioning.	<ul style="list-style-type: none">• VVEL control module

DTC CONFIRMATION PROCEDURE

1. PRECONDITIONING

If DTC Confirmation Procedure has been previously conducted, always perform the following procedure before conducting the next test.

1. Turn ignition switch OFF and wait at least 10 seconds.
2. Turn ignition switch ON.
3. Turn ignition switch OFF and wait at least 10 seconds.

TESTING CONDITION:

Before performing the following procedure, confirm that battery voltage is more than 10 V at idle.

>> GO TO 2.

2. PERFORM DTC CONFIRMATION PROCEDURE

1. Turn ignition switch ON and wait at least 1 second.
2. Check DTC.

Is DTC detected?

- YES >> Go to [EC-453, "Diagnosis Procedure"](#).
NO >> INSPECTION END

Diagnosis Procedure

INFOID:000000005152025

1. PERFORM DTC CONFIRMATION PROCEDURE

1. Turn ignition switch ON.
2. Erase DTC.
3. Perform DTC Confirmation Procedure.
See [EC-453, "DTC Logic"](#).

Is the DTC P1606 displayed again?

- YES >> GO TO 2.
NO >> INSPECTION END

2. REPLACE VVEL CONTROL MODULE

1. Replace VVEL control module.

P1606 VVEL CONTROL MODULE

< DTC/CIRCUIT DIAGNOSIS >

[VQ37VHR]

2. Go to [EC-17. "ADDITIONAL SERVICE WHEN REPLACING CONTROL UNIT \(VVEL CONTROL MODULE\) : Special Repair Requirement"](#).

>> INSPECTION END

P1607 VVEL CONTROL MODULE

< DTC/CIRCUIT DIAGNOSIS >

[VQ37VHR]

P1607 VVEL CONTROL MODULE

Description

INFOID:000000005152026

The VVEL control module consists of a microcomputer and connectors for signal input and output and for power supply. The VVEL control module controls VVEL system.

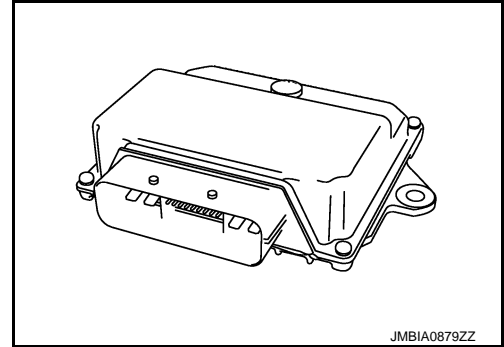

DTC Logic

INFOID:000000005152027

DTC DETECTION LOGIC

DTC No.	Trouble diagnosis name	DTC detecting condition	Possible cause
P1607	VVEL control module circuit	<ul style="list-style-type: none">The internal circuit of the VVEL control module is malfunctioning.	<ul style="list-style-type: none">VVEL control module

DTC CONFIRMATION PROCEDURE

1. PRECONDITIONING

If DTC Confirmation Procedure has been previously conducted, always perform the following procedure before conducting the next test.

- Turn ignition switch OFF and wait at least 10 seconds.
- Turn ignition switch ON.
- Turn ignition switch OFF and wait at least 10 seconds.

TESTING CONDITION:

Before performing the following procedure, confirm that battery voltage is more than 10 V at idle.

>> GO TO 2.

2. PERFORM DTC CONFIRMATION PROCEDURE

- Start engine and let it idle for at least 1 second.
- Check DTC.

Is DTC detected?

- YES >> Go to [EC-455, "Diagnosis Procedure"](#).
NO >> INSPECTION END

Diagnosis Procedure

INFOID:000000005152028

1. PERFORM DTC CONFIRMATION PROCEDURE

- Turn ignition switch ON.
- Erase DTC.
- Perform DTC Confirmation Procedure.
See [EC-455, "DTC Logic"](#).

Is the DTC P1607 displayed again?

- YES >> GO TO 2.
NO >> INSPECTION END

2. REPLACE VVEL CONTROL MODULE

- Replace VVEL control module.

P1607 VVEL CONTROL MODULE

< DTC/CIRCUIT DIAGNOSIS >

[VQ37VHR]

2. Go to [EC-17. "ADDITIONAL SERVICE WHEN REPLACING CONTROL UNIT \(VVEL CONTROL MODULE\) : Special Repair Requirement"](#).

>> INSPECTION END

P1608 VVEL SENSOR POWER SUPPLY

< DTC/CIRCUIT DIAGNOSIS >

[VQ37VHR]

P1608 VVEL SENSOR POWER SUPPLY

DTC Logic

INFOID:000000005152029

DTC DETECTION LOGIC

DTC No.	Trouble diagnosis name	DTC detecting condition	Possible cause
P1608	VVEL sensor power supply circuit	VVEL control module detects a voltage of power source for sensor is excessively low or high.	<ul style="list-style-type: none"> Harness or connectors (VVEL control shaft position sensor power supply circuit is open or shorted.) VVEL control shaft position sensor VVEL control module

DTC CONFIRMATION PROCEDURE

1. PRECONDITIONING

If DTC Confirmation Procedure has been previously conducted, always perform the following procedure before conducting the next test.

- Turn ignition switch OFF and wait at least 10 seconds.
- Turn ignition switch ON.
- Turn ignition switch OFF and wait at least 10 seconds.

TESTING CONDITION:

Before performing the following procedure, confirm that battery voltage is more than 10 V at idle.

>> GO TO 2.

2. PERFORM DTC CONFIRMATION PROCEDURE

- Turn ignition switch ON and wait at least 1 second.
- Check DTC.

Is DTC detected?

- YES >> Go to [EC-457, "Diagnosis Procedure"](#).
 NO >> INSPECTION END

Diagnosis Procedure

INFOID:000000005152030

1. CHECK GROUND CONNECTION

- Turn ignition switch OFF.
- Check ground connection M95, E46. Refer to Ground Inspection in [GI-39, "Circuit Inspection"](#).

Is the inspection result normal?

- YES >> GO TO 2.
 NO >> Repair or replace ground connection.

2. CHECK VVEL CONTROL SHAFT POSITION SENSOR POWER SUPPLY CIRCUIT

- Disconnect VVEL control shaft position sensor harness connector.
- Turn ignition switch ON.
- Check the voltage between VVEL control shaft position sensor harness connector and ground.

VVEL control shaft position sensor			Ground	Voltage (V)
Bank	Connector	Terminal		
1	F46	3	Ground	Approx. 5
		6		
2	F47	3		
		6		

Is the inspection result normal?

- YES >> GO TO 7.
 NO >> GO TO 3.

P1608 VVEL SENSOR POWER SUPPLY

[VQ37VHR]

< DTC/CIRCUIT DIAGNOSIS >

3. CHECK VVEL CONTROL SHAFT POSITION SENSOR POWER SUPPLY CIRCUIT FOR OPEN AND SHORT

1. Turn ignition switch OFF.
2. Disconnect VVEL control module harness connector.
3. Check the continuity between VVEL control shaft position sensor harness connector and VVEL control module harness connector.

VVEL control shaft position sensor			VVEL control module		Continuity
Bank	Connector	Terminal	Connector	Terminal	
1	F46	3	E15	9	Existed
		6		22	
2	F47	3		7	
		6		20	

4. Also check harness for short to ground and power.

Is the inspection result normal?

YES >> GO TO 5.

NO >> GO TO 4.

4. DETECT MALFUNCTIONING PART

Check the following.

- Harness connectors F1, E3
- Harness for open or short between VVEL control shaft position sensor and VVEL control module

>> Repair open circuit, short to ground or short to power in harness or connectors.

5. CHECK INTERMITTENT INCIDENT

Refer to [GI-36, "Intermittent Incident"](#).

Is the inspection result normal?

YES >> GO TO 6.

NO >> Repair or replace.

6. REPLACE VVEL CONTROL MODULE

1. Replace VVEL control module.
2. Go to [EC-17, "ADDITIONAL SERVICE WHEN REPLACING CONTROL UNIT \(VVEL CONTROL MODULE\) : Special Repair Requirement"](#).

>> INSPECTION END

7. CHECK INTERMITTENT INCIDENT

Refer to [GI-36, "Intermittent Incident"](#).

Is the inspection result normal?

YES >> GO TO 8.

NO >> Repair or replace.

8. REPLACE VVEL ACTUATOR SUB ASSEMBLY

1. Replace VVEL actuator sub assembly.
2. Go to [EC-458, "Special Repair Requirement"](#).

>> INSPECTION END

Special Repair Requirement

INFOID:000000005152031

1. PERFORM VVEL CONTROL SHAFT POSITION SENSOR ADJUSTMENT

P1608 VVEL SENSOR POWER SUPPLY

[VQ37VHR]

< DTC/CIRCUIT DIAGNOSIS >

Refer to [EC-21, "VVEL CONTROL SHAFT POSITION SENSOR ADJUSTMENT : Special Repair Requirement"](#).

A

>> GO TO 2.

2.PERFORM IDLE AIR VOLUME LEARNING

EC

Refer to [EC-19, "IDLE AIR VOLUME LEARNING : Special Repair Requirement"](#).

>> END

C

D

E

F

G

H

I

J

K

L

M

N

O

P

P1805 BRAKE SWITCH

< DTC/CIRCUIT DIAGNOSIS >

[VQ37VHR]

P1805 BRAKE SWITCH

Description

INFOID:000000005152032

Brake switch signal is applied to the ECM through the stop lamp switch when the brake pedal is depressed. This signal is used mainly to decrease the engine speed when the vehicle is being driven.

DTC Logic

INFOID:000000005152033

DTC DETECTION LOGIC

DTC No.	Trouble diagnosis name	DTC detecting condition	Possible cause
P1805	Brake switch	A brake switch signal is not sent to ECM for extremely long time while the vehicle is being driven.	<ul style="list-style-type: none"> Harness or connectors (Stop lamp switch circuit is open or shorted.) Stop lamp switch

DTC CONFIRMATION PROCEDURE

1. PERFORM DTC CONFIRMATION PROCEDURE

- Turn ignition switch ON.
- Fully depress the brake pedal for at least 5 seconds.
- Erase the DTC.
- Check 1st trip DTC.

Is 1st trip DTC detected?

- YES >> Go to [EC-460, "Diagnosis Procedure"](#).
 NO >> INSPECTION END

Diagnosis Procedure

INFOID:000000005152034

1. CHECK STOP LAMP SWITCH CIRCUIT

- Turn ignition switch OFF.
- Check the stop lamp when depressing and releasing the brake pedal.

Brake pedal	Stop lamp
Fully released	Not illuminated
Slightly depressed	Illuminated

Is the inspection result normal?

- YES >> GO TO 4.
 NO >> GO TO 2.

2. CHECK STOP LAMP SWITCH POWER SUPPLY CIRCUIT

- Disconnect stop lamp switch harness connector.
- Check the voltage between stop lamp switch harness connector and ground.

Stop lamp switch		Ground	Voltage
Connector	Terminal		
E110	3	Ground	Battery voltage

Is the inspection result normal?

- YES >> GO TO 4.
 NO >> GO TO 3.

3. DETECT MALFUNCTIONING PART

Check the following.

- Fuse block (J/B) connector E103
- 10 A fuse (No. 7)

P1805 BRAKE SWITCH

[VQ37VHR]

< DTC/CIRCUIT DIAGNOSIS >

- Harness for open or short between stop lamp switch and battery

>> Repair open circuit, short to ground or short to power in harness or connectors.

4.CHECK STOP LAMP SWITCH INPUT SIGNAL CIRCUIT FOR OPEN AND SHORT

1. Disconnect stop lamp switch harness connector.
2. Disconnect ECM harness connector.
3. Check the continuity between stop lamp switch harness connector and ECM harness connector.

Stop lamp switch		ECM		Continuity
Connector	Terminal	Connector	Terminal	
E110	4	M107	122	Existed

4. Also check harness for short to ground and short to power.

Is the inspection result normal?

YES >> GO TO 6.

NO >> GO TO 5.

5.DETECT MALFUNCTIONING PART

Check the following.

- Fuse block (J/B) connector E103, M2
- Harness for open or short between ECM and stop lamp switch

>> Repair open circuit, short to ground or short to power in harness or connectors.

6.CHECK STOP LAMP SWITCH

Refer to [EC-461, "Component Inspection \(Stop Lamp Switch\)"](#).

Is the inspection result normal?

YES >> GO TO 7.

NO >> Replace stop lamp switch.

7.CHECK INTERMITTENT INCIDENT

Refer to [GI-36, "Intermittent Incident"](#).

>> INSPECTION END

Component Inspection (Stop Lamp Switch)

INFOID:000000005152035

1.CHECK STOP LAMP SWITCH-I

1. Turn ignition switch OFF.
2. Disconnect stop lamp switch harness connector.
3. Check the continuity between stop lamp switch terminals under the following conditions.

Terminals	Condition		Continuity
1 and 2	Brake pedal	Fully released	Not existed
		Slightly depressed	Existed

Is the inspection result normal?

YES >> INSPECTION END

NO >> GO TO 2.

2.CHECK STOP LAMP SWITCH-II

1. Adjust stop lamp switch installation. Refer to [BR-8, "Inspection and Adjustment"](#).
2. Check the continuity between stop lamp switch terminals under the following conditions.

P1805 BRAKE SWITCH

< DTC/CIRCUIT DIAGNOSIS >

[VQ37VHR]

Terminals	Condition		Continuity
1 and 2	Brake pedal	Fully released	Not existed
		Slightly depressed	Existed

Is the inspection result normal?

YES >> INSPECTION END

NO >> Replace stop lamp switch.

P2122, P2123 APP SENSOR

< DTC/CIRCUIT DIAGNOSIS >

[VQ37VHR]

P2122, P2123 APP SENSOR

Description

INFOID:000000005152036

The accelerator pedal position sensor is installed on the upper end of the accelerator pedal assembly. The sensor detects the accelerator position and sends a signal to the ECM.

Accelerator pedal position sensor has two sensors. These sensors are a kind of potentiometer which transform the accelerator pedal position into output voltage, and emit the voltage signal to the ECM. The ECM judges the current opening angle of the accelerator pedal from these signals and controls the throttle control motor based on these signals.

Idle position of the accelerator pedal is determined by the ECM receiving the signal from the accelerator pedal position sensor. The ECM uses this signal for engine operations such as fuel cut.

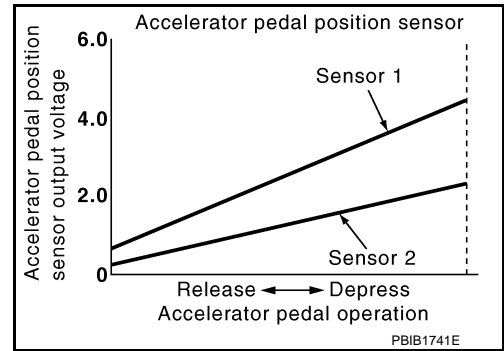

DTC Logic

INFOID:000000005152037

DTC DETECTION LOGIC

NOTE:

If DTC P2122 or P2123 is displayed with DTC P0643, first perform the trouble diagnosis for DTC P0643. Refer to [EC-364, "DTC Logic"](#).

DTC No.	Trouble diagnosis name	DTC detecting condition	Possible cause
P2122	Accelerator pedal position sensor 1 circuit low input	An excessively low voltage from the APP sensor 1 is sent to ECM.	<ul style="list-style-type: none"> Harness or connectors (APP sensor 1 circuit is open or shorted.) Accelerator pedal position sensor (APP sensor 1)
P2123	Accelerator pedal position sensor 1 circuit high input	An excessively high voltage from the APP sensor 1 is sent to ECM.	

DTC CONFIRMATION PROCEDURE

1. PRECONDITIONING

If DTC Confirmation Procedure has been previously conducted, always perform the following procedure before conducting the next test.

- Turn ignition switch OFF and wait at least 10 seconds.
- Turn ignition switch ON.
- Turn ignition switch OFF and wait at least 10 seconds.

TESTING CONDITION:

Before performing the following procedure, confirm that battery voltage is more than 10 V at idle.

>> GO TO 2.

2. PERFORM DTC CONFIRMATION PROCEDURE

- Start engine and let it idle for 1 second.
- Check DTC.

Is DTC detected?

- YES >> Go to [EC-463, "Diagnosis Procedure"](#).
 NO >> INSPECTION END

Diagnosis Procedure

INFOID:000000005152038

1. CHECK GROUND CONNECTION

- Turn ignition switch OFF.
- Check ground connection M95. Refer to Ground Inspection in [GI-39, "Circuit Inspection"](#).

Is the inspection result normal?

P2122, P2123 APP SENSOR

[VQ37VHR]

< DTC/CIRCUIT DIAGNOSIS >

- YES >> GO TO 2.
NO >> Repair or replace ground connection.

2.CHECK APP SENSOR 1 POWER SUPPLY CIRCUIT

1. Disconnect accelerator pedal position (APP) sensor harness connector.
2. Turn ignition switch ON.
3. Check the voltage between APP sensor harness connector and ground.

APP sensor		Ground	Voltage (V)
Connector	Terminal		
E112	5	Ground	Approx. 5

Is the inspection result normal?

- YES >> GO TO 4.
NO >> GO TO 3.

3.DETECT MALFUNCTIONING PART

Check the following.

- Harness connectors M6, E106
- Harness for open or short between ECM and accelerator pedal position sensor

>> Repair open circuit, short to ground or short to power in harness or connectors.

4.CHECK APP SENSOR 1 GROUND CIRCUIT FOR OPEN AND SHORT

1. Turn ignition switch OFF.
2. Disconnect ECM harness connector.
3. Check the continuity between APP sensor harness connector and ECM harness connector.

APP sensor		ECM		Continuity
Connector	Terminal	Connector	Terminal	
E112	4	M107	100	Existed

4. Also check harness for short to ground and short to power.

Is the inspection result normal?

- YES >> GO TO 6.
NO >> GO TO 5.

5.DETECT MALFUNCTIONING PART

Check the following.

- Harness connectors M6, E106
- Harness for open or short between ECM and accelerator pedal position sensor

>> Repair open circuit, short to ground or short to power in harness or connectors.

6.CHECK APP SENSOR 1 INPUT SIGNAL CIRCUIT FOR OPEN AND SHORT

1. Check the continuity between APP sensor harness connector and ECM harness connector.

APP sensor		ECM		Continuity
Connector	Terminal	Connector	Terminal	
E112	3	M107	97	Existed

2. Also check harness for short to ground and short to power.

Is the inspection result normal?

- YES >> GO TO 8.
NO >> GO TO 7.

7.DETECT MALFUNCTIONING PART

P2122, P2123 APP SENSOR

[VQ37VHR]

< DTC/CIRCUIT DIAGNOSIS >

Check the following.

- Harness connectors M6, E106
- Harness for open or short between ECM and accelerator pedal position sensor

>> Repair open circuit, short to ground or short to power in harness or connectors.

8.CHECK APP SENSOR

Refer to [EC-465, "Component Inspection"](#).

Is the inspection result normal?

- YES >> GO TO 10.
- NO >> GO TO 9.

9.REPLACE ACCELERATOR PEDAL ASSEMBLY

1. Replace accelerator pedal assembly.
2. Go to [EC-465, "Special Repair Requirement"](#).

>> INSPECTION END

10.CHECK INTERMITTENT INCIDENT

Refer to [GI-36, "Intermittent Incident"](#).

>> INSPECTION END

Component Inspection

INFOID:000000005152039

1.CHECK ACCELERATOR PEDAL POSITION SENSOR

1. Turn ignition switch OFF.
2. Reconnect all harness connectors disconnected.
3. Turn ignition switch ON.
4. Check the voltage ECM harness connector terminals as per the following.

ECM			Condition	Voltage (V)
Connector	+	-		
	Terminal	Terminal		
M107	97 (APP sensor 1)	100	Fully released	0.45 - 1.0
			Fully depressed	4.4 - 4.8
	98 (APP sensor 2)	104	Fully released	0.22 - 0.50
			Fully depressed	2.1 - 2.5

Is the inspection result normal?

- YES >> INSPECTION END
- NO >> GO TO 2.

2.REPLACE ACCELERATOR PEDAL ASSEMBLY

1. Replace accelerator pedal assembly.
2. Go to [EC-465, "Special Repair Requirement"](#).

>> INSPECTION END

Special Repair Requirement

INFOID:000000005152040

1.PERFORM ACCELERATOR PEDAL RELEASED POSITION LEARNING

Refer to [EC-18, "ACCELERATOR PEDAL RELEASED POSITION LEARNING : Special Repair Requirement"](#).

>> GO TO 2.

P2122, P2123 APP SENSOR

< DTC/CIRCUIT DIAGNOSIS >

[VQ37VHR]

2. PERFORM THROTTLE VALVE CLOSED POSITION LEARNING

Refer to [EC-18. "THROTTLE VALVE CLOSED POSITION LEARNING : Special Repair Requirement"](#).

>> GO TO 3.

3. PERFORM IDLE AIR VOLUME LEARNING

Refer to [EC-19. "IDLE AIR VOLUME LEARNING : Special Repair Requirement"](#).

>> END

P2127, P2128 APP SENSOR

< DTC/CIRCUIT DIAGNOSIS >

[VQ37VHR]

P2127, P2128 APP SENSOR

Description

INFOID:000000005152041

The accelerator pedal position sensor is installed on the upper end of the accelerator pedal assembly. The sensor detects the accelerator position and sends a signal to the ECM.

Accelerator pedal position sensor has two sensors. These sensors are a kind of potentiometer which transform the accelerator pedal position into output voltage, and emit the voltage signal to the ECM. The ECM judges the current opening angle of the accelerator pedal from these signals and controls the throttle control motor based on these signals.

Idle position of the accelerator pedal is determined by the ECM receiving the signal from the accelerator pedal position sensor. The ECM uses this signal for engine operations such as fuel cut.

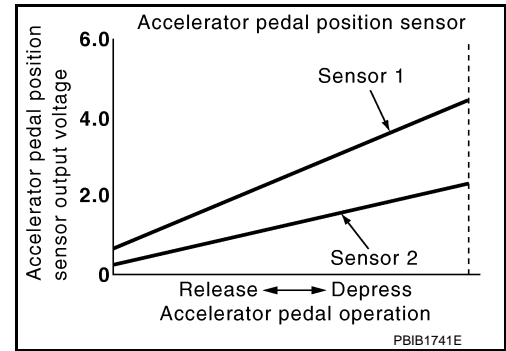

DTC Logic

INFOID:000000005152042

DTC DETECTION LOGIC

DTC No.	Trouble diagnosis name	DTC detecting condition	Possible cause
P2127	Accelerator pedal position sensor 2 circuit low input	An excessively low voltage from the APP sensor 2 is sent to ECM.	<ul style="list-style-type: none"> • Harness or connectors (APP sensor 2 circuit is open or shorted.) [CKP sensor (POS) circuit is shorted.] (EVAP control system pressure sensor circuit is shorted.) (Refrigerant pressure sensor circuit is shorted.) • Accelerator pedal position sensor (APP sensor 2) (Brake booster pressure sensor circuit is shorted) • Crankshaft position sensor (POS) • EVAP control system pressure sensor • Refrigerant pressure sensor • Brake booster pressure sensor
P2128	Accelerator pedal position sensor 2 circuit high input	An excessively high voltage from the APP sensor 2 is sent to ECM.	

DTC CONFIRMATION PROCEDURE

1. PRECONDITIONING

If DTC Confirmation Procedure has been previously conducted, always perform the following procedure before conducting the next test.

1. Turn ignition switch OFF and wait at least 10 seconds.
2. Turn ignition switch ON.
3. Turn ignition switch OFF and wait at least 10 seconds.

TESTING CONDITION:

Before performing the following procedure, confirm that battery voltage is more than 10 V at idle.

>> GO TO 2.

2. PERFORM DTC CONFIRMATION PROCEDURE

1. Start engine and let it idle for 1 second.
2. Check DTC.

Is DTC detected?

- YES >> Go to [EC-468. "Diagnosis Procedure"](#).
 NO >> INSPECTION END

P2127, P2128 APP SENSOR

[VQ37VHR]

< DTC/CIRCUIT DIAGNOSIS >

Diagnosis Procedure

INFOID:000000005152043

1. CHECK GROUND CONNECTION

1. Turn ignition switch OFF.
2. Check ground connection M95. Refer to Ground Inspection in [GI-39. "Circuit Inspection"](#).

Is the inspection result normal?

- YES >> GO TO 2.
NO >> Repair or replace ground connection.

2. CHECK APP SENSOR 2 POWER SUPPLY CIRCUIT-I

1. Disconnect accelerator pedal position (APP) sensor harness connector.
2. Turn ignition switch ON.
3. Check the voltage between APP sensor harness connector and ground.

APP sensor		Ground	Voltage (V)
Connector	Terminal		
E112	6	Ground	Approx. 5

Is the inspection result normal?

- YES >> GO TO 7.
NO >> GO TO 3.

3. CHECK APP SENSOR 2 POWER SUPPLY CIRCUIT-II

1. Turn ignition switch OFF.
2. Disconnect ECM harness connector.
3. Check the continuity between APP sensor harness connector and ECM harness connector.

APP sensor		ECM		Continuity
Connector	Terminal	Connector	Terminal	
E112	6	M107	103	Existed

Is the inspection result normal?

- YES >> GO TO 5.
NO >> GO TO 4.

4. DETECT MALFUNCTIONING PART

Check the following.

- Harness connectors M6, E106
- Harness for open or short between ECM and accelerator pedal position sensor

>> Repair open circuit.

5. CHECK SENSOR POWER SUPPLY CIRCUIT

Check harness for short to power and short to ground, between the following terminals.

ECM		Sensor		
Connector	Terminal	Name	Connector	Terminal
F101	45	Brake booster pressure sensor	E48	1
	46	CKP sensor (POS)	F2	1
M107	103	APP sensor	E112	6
	107	EVAP control system pressure sensor	B30	3
Refrigerant pressure sensor		E77	3	

Is the inspection result normal?

- YES >> GO TO 6.

P2127, P2128 APP SENSOR

[VQ37VHR]

< DTC/CIRCUIT DIAGNOSIS >

NO >> Repair short to ground or short to power in harness or connectors.

6.CHECK COMPONENTS

Check the following.

- Crankshaft position sensor (POS) (Refer to [EC-272. "Component Inspection".](#))
- Brake booster pressure sensor (Refer to [EC-357. "Component Inspection".](#))
- EVAP control system pressure sensor (Refer to [EC-311. "Component Inspection".](#))
- Refrigerant pressure sensor (Refer to [EC-516. "Diagnosis Procedure".](#))

Is the inspection result normal?

YES >> GO TO 13.

NO >> Replace malfunctioning component.

7.CHECK APP SENSOR 2 GROUND CIRCUIT FOR OPEN AND SHORT

1. Turn ignition switch OFF.
2. Disconnect ECM harness connector.
3. Check the continuity between APP sensor harness connector and ECM harness connector.

APP sensor		ECM		Continuity
Connector	Terminal	Connector	Terminal	
E112	2	M107	104	Existed

4. Also check harness for short to ground and short to power.

Is the inspection result normal?

YES >> GO TO 9.

NO >> GO TO 8.

8.DETECT MALFUNCTIONING PART

Check the following.

- Harness connectors M6, E106
- Harness for open or short between ECM and accelerator pedal position sensor

>> Repair open circuit, short to ground or short to power in harness or connectors.

9.CHECK APP SENSOR 2 INPUT SIGNAL CIRCUIT FOR OPEN AND SHORT

1. Check the continuity between APP sensor harness connector and ECM harness connector.

APP sensor		ECM		Continuity
Connector	Terminal	Connector	Terminal	
E112	1	M107	98	Existed

2. Also check harness for short to ground and short to power.

Is the inspection result normal?

YES >> GO TO 11.

NO >> GO TO 10.

10.DETECT MALFUNCTIONING PART

Check the following.

- Harness connectors M6, E106
- Harness for open or short between ECM and accelerator pedal position sensor

>> Repair open circuit, short to ground or short to power in harness or connectors.

11.CHECK APP SENSOR

Refer to [EC-470. "Component Inspection".](#)

Is the inspection result normal?

YES >> GO TO 13.

NO >> GO TO 12.

P2127, P2128 APP SENSOR

< DTC/CIRCUIT DIAGNOSIS >

[VQ37VHR]

12. REPLACE ACCELERATOR PEDAL ASSEMBLY

1. Replace accelerator pedal assembly.
2. Go to [EC-470, "Special Repair Requirement"](#).

>> INSPECTION END

13. CHECK INTERMITTENT INCIDENT

Refer to [GI-39, "Circuit Inspection"](#).

>> INSPECTION END

Component Inspection

INFOID:000000005152044

1. CHECK ACCELERATOR PEDAL POSITION SENSOR

1. Turn ignition switch OFF.
2. Reconnect all harness connectors disconnected.
3. Turn ignition switch ON.
4. Check the voltage ECM harness connector terminals as per the following.

Connector	ECM		Condition	Voltage (V)
	+	-		
	Terminal	Terminal		
M107	97 (APP sensor 1)	100	Fully released	0.45 - 1.0
			Fully depressed	4.4 - 4.8
	98 (APP sensor 2)	104	Fully released	0.22 - 0.50
			Fully depressed	2.1 - 2.5

Is the inspection result normal?

YES >> INSPECTION END

NO >> GO TO 2.

2. REPLACE ACCELERATOR PEDAL ASSEMBLY

1. Replace accelerator pedal assembly.
2. Go to [EC-465, "Special Repair Requirement"](#).

>> INSPECTION END

Special Repair Requirement

INFOID:000000005152045

1. PERFORM ACCELERATOR PEDAL RELEASED POSITION LEARNING

Refer to [EC-18, "ACCELERATOR PEDAL RELEASED POSITION LEARNING : Special Repair Requirement"](#).

>> GO TO 2.

2. PERFORM THROTTLE VALVE CLOSED POSITION LEARNING

Refer to [EC-18, "THROTTLE VALVE CLOSED POSITION LEARNING : Special Repair Requirement"](#).

>> GO TO 3.

3. PERFORM IDLE AIR VOLUME LEARNING

Refer to [EC-19, "IDLE AIR VOLUME LEARNING : Special Repair Requirement"](#).

>> END

P2138 APP SENSOR

Description

INFOID:000000005152046

The accelerator pedal position sensor is installed on the upper end of the accelerator pedal assembly. The sensor detects the accelerator position and sends a signal to the ECM.

Accelerator pedal position sensor has two sensors. These sensors are a kind of potentiometer which transform the accelerator pedal position into output voltage, and emit the voltage signal to the ECM. The ECM judges the current opening angle of the accelerator pedal from these signals and controls the throttle control motor based on these signals.

Idle position of the accelerator pedal is determined by the ECM receiving the signal from the accelerator pedal position sensor. The ECM uses this signal for engine operations such as fuel cut.

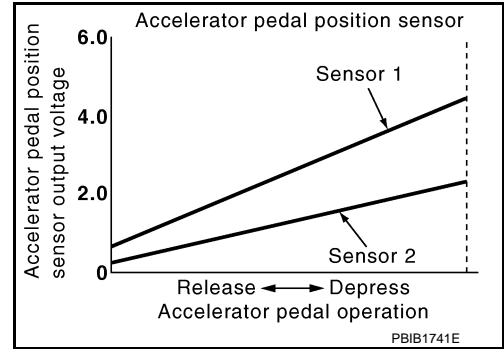

DTC Logic

INFOID:000000005152047

DTC DETECTION LOGIC

NOTE:

If DTC P2138 is displayed with DTC P0643, first perform the trouble diagnosis for DTC P0643. Refer to [EC-364, "DTC Logic"](#).

DTC No.	Trouble diagnosis name	DTC detecting condition	Possible cause
P2138	Accelerator pedal position sensor circuit range/performance	Rationally incorrect voltage is sent to ECM compared with the signals from APP sensor 1 and APP sensor 2.	<ul style="list-style-type: none"> Harness or connectors (APP sensor 2 circuit is open or shorted.) [CKP sensor (POS) circuit is shorted.] (EVAP control system pressure sensor circuit is shorted.) (Refrigerant pressure sensor circuit is shorted.) Accelerator pedal position sensor (APP sensor 2) (Brake booster pressure sensor circuit is shorted) Crankshaft position sensor (POS) EVAP control system pressure sensor Brake booster pressure sensor Refrigerant pressure sensor

DTC CONFIRMATION PROCEDURE

1. PRECONDITIONING

If DTC Confirmation Procedure has been previously conducted, always perform the following procedure before conducting the next test.

- Turn ignition switch OFF and wait at least 10 seconds.
- Turn ignition switch ON.
- Turn ignition switch OFF and wait at least 10 seconds.

TESTING CONDITION:

Before performing the following procedure, confirm that battery voltage is more than 10 V at idle.

>> GO TO 2.

2. PERFORM DTC CONFIRMATION PROCEDURE

- Start engine and let it idle for 1 second.
- Check DTC.

Is DTC detected?

- YES >> Go to [EC-472, "Diagnosis Procedure"](#).
- NO >> INSPECTION END

Diagnosis Procedure

INFOID:000000005152048

1.CHECK GROUND CONNECTION

1. Turn ignition switch OFF.
2. Check ground connection M95. Refer to Ground Inspection in [GI-39. "Circuit Inspection"](#).

Is the inspection result normal?

- YES >> GO TO 2.
- NO >> Repair or replace ground connection.

2.CHECK APP SENSOR 1 POWER SUPPLY CIRCUIT

1. Disconnect accelerator pedal position (APP) sensor harness connector.
2. Turn ignition switch ON.
3. Check the voltage between APP sensor harness connector and ground.

APP sensor		Ground	Voltage (V)
Connector	Terminal		
E112	5	Ground	Approx. 5

Is the inspection result normal?

- YES >> GO TO 4.
- NO >> GO TO 3.

3.DETECT MALFUNCTIONING PART

Check the following.

- Harness connectors M6, E106
- Harness for open or short between ECM and accelerator pedal position sensor

>> Repair open circuit, short to ground or short to power in harness or connectors.

4.CHECK APP SENSOR 2 POWER SUPPLY CIRCUIT-I

1. Turn ignition switch ON.
2. Check the voltage between APP sensor harness connector and ground.

APP sensor		Ground	Voltage (V)
Connector	Terminal		
E112	6	Ground	Approx. 5

Is the inspection result normal?

- YES >> GO TO 9.
- NO >> GO TO 5.

5.CHECK APP SENSOR 2 POWER SUPPLY CIRCUIT-II

1. Turn ignition switch OFF.
2. Disconnect ECM harness connector.
3. Check the continuity between APP sensor harness connector and ECM harness connector.

APP sensor		ECM		Continuity
Connector	Terminal	Connector	Terminal	
E112	6	M107	103	Existed

Is the inspection result normal?

- YES >> GO TO 7.
- NO >> GO TO 6.

6.DETECT MALFUNCTIONING PART

Check the following.

- Harness connectors M6, E106

P2138 APP SENSOR

[VQ37VHR]

< DTC/CIRCUIT DIAGNOSIS >

- Harness for open or short between ECM and accelerator pedal position sensor

>> Repair open circuit.

7. CHECK SENSOR POWER SUPPLY CIRCUIT

Check harness for short to power and short to ground, between the following terminals.

ECM		Sensor		
Connector	Terminal	Name	Connector	Terminal
F101	45	Brake booster pressure sensor	E48	1
	46	CKP sensor (POS)	F2	1
M107	103	APP sensor	E112	6
	107	EVAP control system pressure sensor	B30	3
		Refrigerant pressure sensor	E77	3

Is the inspection result normal?

YES >> GO TO 8.

NO >> Repair short to ground or short to power in harness or connectors.

8. CHECK COMPONENTS

Check the following.

- Crankshaft position sensor (POS) (Refer to [EC-272, "Component Inspection"](#).)
- Brake booster pressure sensor (Refer to [EC-357, "Component Inspection"](#).)
- EVAP control system pressure sensor (Refer to [EC-311, "Component Inspection"](#).)
- Refrigerant pressure sensor (Refer to [EC-516, "Diagnosis Procedure"](#).)

Is the inspection result normal?

YES >> GO TO 15.

NO >> Replace malfunctioning component.

9. CHECK APP SENSOR GROUND CIRCUIT FOR OPEN AND SHORT

1. Turn ignition switch OFF.
2. Disconnect ECM harness connector.
3. Check the continuity between APP sensor harness connector and ECM harness connector.

APP sensor		ECM		Continuity
Connector	Terminal	Connector	Terminal	
E112	4	M107	100	Existed
	2		104	

4. Also check harness for short to ground and short to power.

Is the inspection result normal?

YES >> GO TO 11.

NO >> GO TO 10.

10. DETECT MALFUNCTIONING PART

Check the following.

- Harness connectors M6, E106
- Harness for open or short between ECM and accelerator pedal position sensor

>> Repair open circuit, short to ground or short to power in harness or connectors.

11. CHECK APP SENSOR INPUT SIGNAL CIRCUIT FOR OPEN AND SHORT

1. Check the continuity between APP sensor harness connector and ECM harness connector.

P2138 APP SENSOR

[VQ37VHR]

< DTC/CIRCUIT DIAGNOSIS >

APP sensor		ECM		Continuity
Connector	Terminal	Connector	Terminal	
E112	3	M107	97	Existed
	1		98	

2. Also check harness for short to ground and short to power.

Is the inspection result normal?

YES >> GO TO 13.

NO >> GO TO 12.

12.DETECT MALFUNCTIONING PART

Check the following.

- Harness connectors M6, E106
- Harness for open or short between ECM and accelerator pedal position sensor

>> Repair open circuit, short to ground or short to power in harness or connectors.

13.CHECK APP SENSOR

Refer to [EC-474, "Component Inspection"](#).

Is the inspection result normal?

YES >> GO TO 15.

NO >> GO TO 14.

14.REPLACE ACCELERATOR PEDAL ASSEMBLY

1. Replace accelerator pedal assembly.
2. Go to [EC-475, "Special Repair Requirement"](#).

>> INSPECTION END

15.CHECK INTERMITTENT INCIDENT

Refer to [GI-36, "Intermittent Incident"](#).

>> INSPECTION END

Component Inspection

INFOID:000000005152049

1.CHECK ACCELERATOR PEDAL POSITION SENSOR

1. Turn ignition switch OFF.
2. Reconnect all harness connectors disconnected.
3. Turn ignition switch ON.
4. Check the voltage ECM harness connector terminals as per the following.

Connector	ECM		Condition	Voltage (V)
	+	-		
	Terminal	Terminal		
M107	97 (APP sensor 1)	100	Fully released	0.45 - 1.0
			Fully depressed	4.4 - 4.8
	98 (APP sensor 2)	104	Fully released	0.22 - 0.50
			Fully depressed	2.1 - 2.5

Is the inspection result normal?

YES >> INSPECTION END

NO >> GO TO 2.

P2138 APP SENSOR

< DTC/CIRCUIT DIAGNOSIS >

[VQ37VHR]

2. REPLACE ACCELERATOR PEDAL ASSEMBLY

1. Replace accelerator pedal assembly.
2. Go to [EC-465, "Special Repair Requirement"](#).

>> INSPECTION END

Special Repair Requirement

INFOID:000000005152050

1. PERFORM ACCELERATOR PEDAL RELEASED POSITION LEARNING

Refer to [EC-18, "ACCELERATOR PEDAL RELEASED POSITION LEARNING : Special Repair Requirement"](#).

>> GO TO 2.

2. PERFORM THROTTLE VALVE CLOSED POSITION LEARNING

Refer to [EC-18, "THROTTLE VALVE CLOSED POSITION LEARNING : Special Repair Requirement"](#).

>> GO TO 3.

3. PERFORM IDLE AIR VOLUME LEARNING

Refer to [EC-19, "IDLE AIR VOLUME LEARNING : Special Repair Requirement"](#).

>> END

A

EC

C

D

E

F

G

H

I

J

K

L

M

N

O

P

P2A00, P2A03 A/F SENSOR 1

Description

INFOID:000000005152051

The air fuel ratio (A/F) sensor 1 is a planar one-cell limit current sensor. The sensor element of the A/F sensor 1 is composed an electrode layer, which transports ions. It has a heater in the element. The sensor is capable of precise measurement $\lambda = 1$, but also in the lean and rich range. Together with its control electronics, the sensor outputs a clear, continuous signal throughout a wide λ range. The exhaust gas components diffuse through the diffusion layer at the sensor cell. An electrode layer is applied voltage, and this current relative oxygen density in lean. Also this current relative hydrocarbon density in rich.

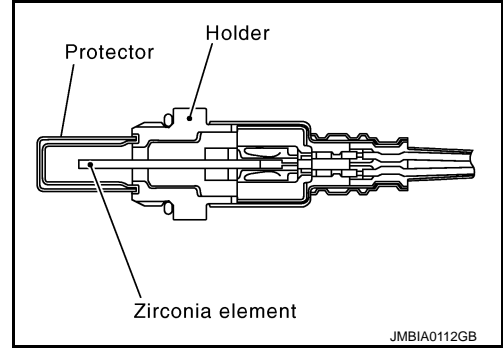

Therefore, the A/F sensor 1 is able to indicate air fuel ratio by this electrode layer of current. In addition, a heater is integrated in the sensor to ensure the required operating temperature of about 800°C (1,472°F).

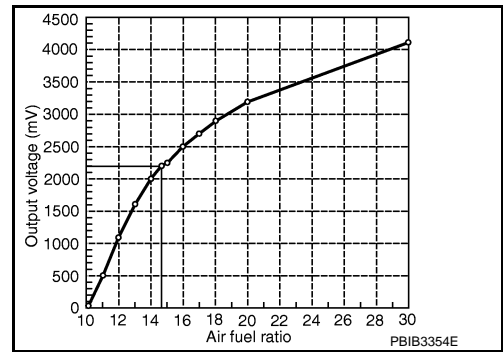

DTC Logic

INFOID:000000005152052

DTC DETECTION LOGIC

To judge the malfunction, the A/F signal computed by ECM from the A/F sensor 1 signal is monitored not it will shift to LEAN side or RICH side.

DTC No.	Trouble diagnosis name	DTC detecting condition	Possible Cause
P2A00	Air fuel ratio (A/F) sensor 1 (bank 1) circuit range/performance	<ul style="list-style-type: none"> The output voltage computed by ECM from the A/F sensor 1 signal is shifts to the lean side for a specified period. 	<ul style="list-style-type: none"> A/F sensor 1 A/F sensor 1 heater Fuel pressure Fuel injector Intake air leaks
P2A03	Air fuel ratio (A/F) sensor 1 (bank 2) circuit range/performance	<ul style="list-style-type: none"> The A/F signal computed by ECM from the A/F sensor 1 signal is shifts to the rich side for a specified period. 	

DTC CONFIRMATION PROCEDURE

1. PRECONDITIONING

If DTC Confirmation Procedure has been previously conducted, always perform the following procedure before conducting the next test.

1. Turn ignition switch OFF and wait at least 10 seconds.
2. Turn ignition switch ON.
3. Turn ignition switch OFF and wait at least 10 seconds.

TESTING CONDITION:

Before performing the following procedure, confirm that battery voltage is more than 11 V at idle.

>> GO TO 2.

2. PERFORM DTC CONFIRMATION PROCEDURE

1. Clear the mixture ratio self-learning value. Refer to [EC-22. "MIXTURE RATIO SELF-LEARNING VALUE CLEAR : Special Repair Requirement"](#).
2. Turn ignition switch OFF and wait at least 10 seconds.

P2A00, P2A03 A/F SENSOR 1

[VQ37VHR]

< DTC/CIRCUIT DIAGNOSIS >

3. Turn ignition switch ON.
4. Turn ignition switch OFF and wait at least 10 seconds.
5. Start engine and keep the engine speed between 3,500 and 4,000 rpm for 1 minute under no load.
6. Let engine idle for 1 minute.
7. Keep engine speed between 2,500 and 3,000 rpm for 20 minutes.
8. Check 1st trip DTC.

Is 1st trip DTC detected?

- YES >> Go to [EC-477, "Diagnosis Procedure"](#).
NO >> INSPECTION END

Diagnosis Procedure

INFOID:000000005152053

1.CHECK GROUND CONNECTION

1. Turn ignition switch OFF.
2. Check ground connection M95. Refer to Ground Inspection in [GI-39, "Circuit Inspection"](#).

Is the inspection result normal?

- YES >> GO TO 2.
NO >> Repair or replace ground connection.

2.RETIGHTEN A/F SENSOR 1

1. Loosen and retighten the A/F sensor 1. Refer to [EM-34, "Removal and Installation"](#).

>> GO TO 3.

3.CHECK FOR INTAKE AIR LEAK

1. Start engine and run it at idle.
2. Listen for an intake air leak after the mass air flow sensor.

Is intake air leak detected?

- YES >> Repair or replace.
NO >> GO TO 4.

4.CLEAR THE MIXTURE RATIO SELF-LEARNING VALUE

1. Clear the mixture ratio self-learning value. Refer to [EC-22, "MIXTURE RATIO SELF-LEARNING VALUE CLEAR : Special Repair Requirement"](#).
2. Run engine for at least 10 minutes at idle speed.

Is the 1st trip DTC P0171, P0172, P0174 or P0175 detected? Is it difficult to start engine?

- YES >> Perform trouble diagnosis for DTC P0171, P0174 or P0172, P0175. Refer to [EC-237, "Diagnosis Procedure"](#) or [EC-241, "Diagnosis Procedure"](#).
NO >> GO TO 5.

5.CHECK HARNESS CONNECTOR

1. Turn ignition switch OFF.
2. Disconnect A/F sensor 1 harness connector.
3. Check harness connector for water.

Water should not exit.

Is the inspection result normal?

- YES >> GO TO 6.
NO >> Repair or replace harness connector.

6.CHECK A/F SENSOR 1 POWER SUPPLY CIRCUIT

1. Turn ignition switch ON.
2. Check the voltage between A/F sensor 1 harness connector and ground.

P2A00, P2A03 A/F SENSOR 1

< DTC/CIRCUIT DIAGNOSIS >

[VQ37VHR]

DTC	A/F sensor 1			Ground	Voltage
	Bank	Connector	Terminal		
P2A00	1	F3	4	Ground	Battery voltage
P2A03	2	F20	4		

Is the inspection result normal?

YES >> GO TO 8.

NO >> GO TO 7.

7. DETECT MALFUNCTIONING PART

Check the following.

- Harness connectors E3, F1
- IPDM E/R harness connector E7
- 15 A fuse (No. 46)
- Harness for open or short between A/F sensor 1 and fuse

>> Repair or replace harness or connectors.

8. CHECK A/F SENSOR 1 INPUT SIGNAL CIRCUIT FOR OPEN AND SHORT

1. Turn ignition switch OFF.
2. Disconnect ECM harness connector.
3. Check the continuity between A/F sensor 1 harness connector and ECM harness connector.

DTC	A/F sensor 1			ECM		Continuity
	Bank	Connector	Terminal	Connector	Terminal	
P2A00	1	F3	1	F102	57	Existed
			2		61	
P2A03	2	F20	1		65	
			2		66	

4. Check the continuity between A/F sensor 1 harness connector and ground, or ECM harness connector and ground.

DTC	A/F sensor 1			Ground	Continuity
	Bank	Connector	Terminal		
P2A00	1	F3	1	Ground	Not existed
			2		
P2A03	2	F20	1		
			2		

DTC	ECM			Ground	Continuity
	Bank	Connector	Terminal		
P2A00	1	F102	57	Ground	Not existed
			61		
P2A03	2		65		
			66		

5. Also check harness for short to power.

Is the inspection result normal?

YES >> GO TO 9.

NO >> Repair open circuit, short to ground or short to power in harness or connectors.

9. CHECK A/F SENSOR 1 HEATER

< DTC/CIRCUIT DIAGNOSIS >

Refer to [EC-158, "Component Inspection"](#).

Is the inspection result normal?

YES >> GO TO 10.

NO >> GO TO 11.

10. CHECK INTERMITTENT INCIDENT

Perform [GI-36, "Intermittent Incident"](#).

Is the inspection result normal?

YES >> GO TO 11.

NO >> Repair or replace.

11. REPLACE AIR FUEL RATIO (A/F) SENSOR 1

Replace air fuel ratio (A/F) sensor 1.

CAUTION:

- Discard any A/F sensor which has been dropped from a height of more than 0.5 m (19.7 in) onto a hard surface such as a concrete floor; use a new one.
- Before installing new A/F sensor, clean exhaust system threads using Oxygen Sensor Thread Cleaner [commercial service tool (J-43897-18 or J-43897-12)] and approved Anti-seize Lubricant (commercial service tool).

Do you have CONSULT-III?

YES >> GO TO 12.

NO >> GO TO 13.

12. CONFIRM A/F ADJUSTMENT DATA

 **With CONSULT-III**

1. Turn ignition switch ON.
2. Select "A/F ADJ-B1" and "A/F ADJ-B2" in "DATA MONITOR" mode with CONSULT-III.
3. Make sure that "0.000" is displayed on CONSULT-III screen.

Is "0.000" displayed?

YES >> INSPECTION END

NO >> GO TO 13.

13. CLEAR THE MIXTURE RATIO SELF-LEARNING VALUE

Clear the mixture ratio self-learning value. Refer to [EC-22, "MIXTURE RATIO SELF-LEARNING VALUE CLEAR : Special Repair Requirement"](#).

Do you have CONSULT-III?

YES >> GO TO 14.

NO >> INSPECTION END

14. CONFIRM A/F ADJUSTMENT DATA

 **With CONSULT-III**

1. Turn ignition switch ON.
2. Select "A/F ADJ-B1" and "A/F ADJ-B2" in "DATA MONITOR" mode with CONSULT-III.
3. Make sure that "0.000" is displayed on CONSULT-III screen.

>> INSPECTION END

A
EC
C
D
E
F
G
H
I
J
K
L
M
N
O
P

ASCD BRAKE SWITCH

< DTC/CIRCUIT DIAGNOSIS >

[VQ37VHR]

ASCD BRAKE SWITCH

Description

INFOID:000000005152054

When the brake pedal is depressed, ASCD brake switch is turned OFF and stop lamp switch is turned ON. ECM detects the state of the brake pedal by those two types of input (ON/OFF signal). Refer to [EC-62. "System Description"](#) for the ASCD function.

Component Function Check

INFOID:000000005152055

1. CHECK ASCD BRAKE SWITCH FUNCTION

With CONSULT-III

1. Turn ignition switch ON.
2. Select "BRAKE SW1" in "DATA MONITOR" mode with CONSULT-III.
3. Check "BRAKE SW1" indication under the following conditions.

Monitor item	Condition		Indication
BRAKE SW1	Brake pedal (A/T) Brake pedal or clutch pedal (M/T)	Slightly depressed	OFF
	Brake pedal (A/T) Brake pedal and clutch pedal (M/T)	Fully released	ON

Without CONSULT-III

1. Turn ignition switch ON.
2. Check the voltage between ECM harness connector terminals as per the following.

Connector	ECM		Condition	Voltage (V)	
	+	-			
	Terminal	Terminal			
M107	126 (ASCD brake switch signal)	128	Brake pedal (A/T) Brake pedal or clutch pedal (M/T)	Slightly depressed	Approx. 0
			Brake pedal (A/T) Brake pedal and clutch pedal (M/T)	Fully released	Battery voltage

Is the inspection result normal?

- YES >> INSPECTION END
 NO >> Go to [EC-480. "Diagnosis Procedure"](#).

Diagnosis Procedure

INFOID:000000005152056

1. INSPECTION START

Check which type of transmission the vehicle is equipped with.

Which type of transmission?

- A/T >> GO TO 2.
 M/T >> GO TO 7.

2. CHECK ASCD BRAKE SWITCH POWER SUPPLY CIRCUIT

1. Turn ignition switch OFF.
2. Disconnect ASCD brake switch harness connector.
3. Turn ignition switch ON.
4. Check the voltage between ASCD brake switch harness connector and ground.

ASCD brake switch		Ground	Voltage
Connector	Terminal		
E109	1	Ground	Battery voltage

Is the inspection result normal?

ASCD BRAKE SWITCH

[VQ37VHR]

< DTC/CIRCUIT DIAGNOSIS >

- YES >> GO TO 4.
- NO >> GO TO 3.

3. DETECT MALFUNCTIONING PART

Check the following.

- Fuse block (J/B) connector E103
- 10 A fuse (No. 3)
- Harness for open or short between ASCD brake switch and fuse

>> Repair open circuit or short to ground in harness or connectors.

4. CHECK ASCD BRAKE SWITCH INPUT SIGNAL CIRCUIT FOR OPEN AND SHORT

1. Turn ignition switch OFF.
2. Disconnect ECM harness connector.
3. Check the continuity between ASCD brake switch harness connector and ECM harness connector.

ASCD brake switch		ECM		Continuity
Connector	Terminal	Connector	Terminal	
E109	2	M107	126	Existed

4. Also check harness for short to ground and short to power.

Is the inspection result normal?

- YES >> GO TO 6.
- NO >> GO TO 5.

5. DETECT MALFUNCTIONING PART

Check the following.

- Harness connectors E106, M6
- Harness for open or short between ECM and ASCD brake switch

>> Repair open circuit, short to ground or short to power in harness or connectors.

6. CHECK ASCD BRAKE SWITCH

Refer to [EC-483. "Component Inspection \(ASCD Brake Switch\)"](#)

Is the inspection result normal?

- YES >> GO TO 15.
- NO >> Replace ASCD brake switch.

7. CHECK ASCD CLUTCH SWITCH CIRCUIT

1. Turn ignition switch OFF.
2. Disconnect ASCD brake switch harness connector.
3. Turn ignition switch ON.
4. Check the voltage between ASCD brake switch harness connector and ground.

ASCD brake switch		Ground	Condition	Voltage (V)	
Connector	Terminal				
E109	1	Ground	Clutch pedal	Slightly depressed	Approx. 0
				Fully released	Battery voltage

Is the inspection result normal?

- YES >> GO TO 12.
- NO >> GO TO 8.

8. CHECK ASCD CLUTCH SWITCH POWER SUPPLY CIRCUIT

1. Turn ignition switch OFF.
2. Disconnect ASCD clutch switch harness connector.
3. Turn ignition switch ON.

ASCD BRAKE SWITCH

[VQ37VHR]

< DTC/CIRCUIT DIAGNOSIS >

4. Check the voltage between ASCD clutch switch harness connector and ground.

ASCD clutch switch		Ground	Voltage
Connector	Terminal		
E108	1	Ground	Battery voltage

Is the inspection result normal?

- YES >> GO TO 10.
NO >> GO TO 9.

9. DETECT MALFUNCTIONING PART

Check the following.

- Fuse block (J/B) connector E103
- 10A fuse (No. 3)
- Harness for open or short between ASCD clutch switch and fuse

>> Repair open circuit or short to ground in harness or connectors.

10. CHECK ASCD BRAKE SWITCH INPUT SIGNAL CIRCUIT FOR OPEN AND SHORT

1. Turn ignition switch OFF.
2. Check the continuity between ASCD clutch switch harness connector and ASCD brake switch harness connector.

ASCD clutch switch		ASCD brake switch		Continuity
Connector	Terminal	Connector	Terminal	
E108	2	E109	1	Existed

3. Also check harness for short to ground and short to power.

Is the inspection result normal?

- YES >> GO TO 11.
NO >> Repair open circuit, short to ground or short to power in harness or connectors.

11. CHECK ASCD CLUTCH SWITCH

Refer to [EC-483, "Component Inspection \(ASCD Clutch Switch\)"](#).

Is the inspection result normal?

- YES >> GO TO 15.
NO >> Replace ASCD clutch switch.

12. CHECK ASCD BRAKE SWITCH INPUT SIGNAL CIRCUIT FOR OPEN AND SHORT

1. Turn ignition switch OFF.
2. Disconnect ECM harness connector.
3. Check the continuity between ASCD brake switch harness connector and ECM harness connector.

ASCD brake switch		ECM		Continuity
Connector	Terminal	Connector	Terminal	
E109	2	M107	126	Existed

4. Also check harness for short to ground and short to power.

Is the inspection result normal?

- YES >> GO TO 14.
NO >> GO TO 13.

13. DETECT MALFUNCTIONING PART

Check the following.

- Harness connectors E106, M6
- Harness for open or short between ECM and ASCD brake switch

ASCD BRAKE SWITCH

< DTC/CIRCUIT DIAGNOSIS >

[VQ37VHR]

>> Repair open circuit, short to ground or short to power in harness or connectors.

14.CHECK ASCD BRAKE SWITCH

Refer to [EC-483. "Component Inspection \(ASCD Brake Switch\)".](#)

Is the inspection result normal?

YES >> GO TO 15.

NO >> Replace ASCD brake switch.

15.CHECK INTERMITTENT INCIDENT

Refer to [GI-36. "Intermittent Incident".](#)

>> INSPECTION END

Component Inspection (ASCD Brake Switch)

INFOID:000000005152057

1.CHECK ASCD BRAKE SWITCH-I

1. Turn ignition switch OFF.
2. Disconnect ASCD brake switch harness connector.
3. Check the continuity between ASCD brake switch terminals under the following conditions.

Terminals	Condition		Continuity
1 and 2	Brake pedal	Fully released	Existed
		Slightly depressed	Not existed

Is the inspection result normal?

YES >> INSPECTION END

NO >> GO TO 2.

2.CHECK ASCD BRAKE SWITCH-II

1. Adjust ASCD brake switch installation. Refer to [BR-8. "Inspection and Adjustment".](#)
2. Check the continuity between ASCD brake switch terminals under the following conditions.

Terminals	Condition		Continuity
1 and 2	Brake pedal	Fully released	Existed
		Slightly depressed	Not existed

Is the inspection result normal?

YES >> INSPECTION END

NO >> Replace ASCD brake switch.

Component Inspection (ASCD Clutch Switch)

INFOID:000000005152058

1.CHECK ASCD CLUTCH SWITCH-I

1. Turn ignition switch OFF.
2. Disconnect ASCD clutch switch harness connector.
3. Check the continuity between ASCD clutch switch terminals under the following conditions.

Terminals	Condition		Continuity
1 and 2	Clutch pedal	Fully released	Existed
		Slightly depressed	Not existed

Is the inspection result normal?

YES >> INSPECTION END

NO >> GO TO 2.

2.CHECK ASCD CLUTCH SWITCH-II

1. Adjust ASCD clutch switch installation. Refer to [CL-6. "Inspection and Adjustment".](#)

ASCD BRAKE SWITCH

[VQ37VHR]

< DTC/CIRCUIT DIAGNOSIS >

2. Check the continuity between ASCD clutch switch terminals under the following conditions.

Terminals	Condition		Continuity
1 and 2	Clutch pedal	Fully released	Existed
		Slightly depressed	Not existed

Is the inspection result normal?

YES >> INSPECTION END

NO >> Replace ASCD clutch switch.

ASCD INDICATOR

< DTC/CIRCUIT DIAGNOSIS >

[VQ37VHR]

ASCD INDICATOR

Description

INFOID:000000005152059

ASCD operation status is indicated by two indicators (CRUISE and SET) and CRUISE lamp on combination meter.

CRUISE indicator is displayed to indicate that ASCD system is ready for operation when MAIN switch on ASCD steering switch is turned ON.

SET indicator is displayed when the following conditions are met.

- CRUISE indicator is displayed.
- SET/COAST switch on ASCD steering switch is turned ON while vehicle speed is within the range of the ASCD setting.

SET indicator is displayed during ASCD control.

Refer to [EC-62. "System Description"](#) for the ASCD function.

Component Function Check

INFOID:000000005152060

1. CHECK ASCD INDICATOR FUNCTION

Check ASCD indicator under the following conditions.

ASCD INDICATOR	CONDITION		SPECIFICATION
CRUISE LAMP	<ul style="list-style-type: none">• Ignition switch: ON	<ul style="list-style-type: none">• MAIN switch: Pressed at the 1st time → at the 2nd time	ON → OFF
SET LAMP	<ul style="list-style-type: none">• MAIN switch: ON• When vehicle speed is between 40 km/h (25 MPH) and 144 km/h (89 MPH)	<ul style="list-style-type: none">• ASCD: Operating	ON
		<ul style="list-style-type: none">• ASCD: Not operating	OFF

Is the inspection result normal?

YES >> INSPECTION END

NO >> Go to [EC-485. "Diagnosis Procedure"](#).

Diagnosis Procedure

INFOID:000000005152061

1. CHECK DTC

Check that DTC UXXXX is not displayed.

Is the inspection result normal?

YES >> GO TO 2.

NO >> Perform trouble diagnosis for DTC UXXXX.

2. CHECK DTC WITH "UNIFIED METER AND A/C AMP."

Refer to [MWI-37. "CONSULT-III Function \(METER/M&A\)"](#).

Is the inspection result normal?

YES >> GO TO 3.

NO >> Repair or replace.

3. CHECK INTERMITTENT INCIDENT

Refer to [GI-36. "Intermittent Incident"](#).

Is the inspection result normal?

YES >> Replace combination meter.

NO >> Repair or replace.

COOLING FAN

< DTC/CIRCUIT DIAGNOSIS >

[VQ37VHR]

COOLING FAN

Description

INFOID:000000005152062

COOLING FAN CONTROL MODULE

Cooling fan control module receives ON/OFF pulse duty signal from IPDM E/R. Corresponding to this ON/OFF pulse duty signal, cooling fan control module sends cooling fan motor operating voltage to cooling fan motor. The revolution speed of cooling fan motor is controlled by duty cycle of the voltage.

COOLING FAN MOTOR

Cooling fan motor receives cooling fan motor operating voltage from cooling fan control module. The revolution speed of cooling fan motor is controlled by duty cycle of the voltage.

Component Function Check

INFOID:000000005152063

1. CHECK COOLING FAN FUNCTION

With CONSULT-III

1. Turn ignition switch ON.
2. Perform "FAN DUTY CONTROL" in "ACTIVE TEST" mode with CONSULT-III.
3. Make sure that cooling fan speed varies according to the percentage.

Without CONSULT-III

1. Perform IPDM E/R auto active test and check cooling fan motors operation, refer to [PCS-9, "Diagnosis Description"](#).
2. Make sure that cooling fan operates.

Is the inspection result normal?

- YES >> INSPECTION END
NO >> Go to [EC-486, "Diagnosis Procedure"](#).

Diagnosis Procedure

INFOID:000000005152064

1. CHECK COOLING FAN CONTROL MODULE POWER SUPPLY CIRCUIT-I

1. Turn ignition switch OFF.
2. Disconnect cooling fan control module harness connector E37.
3. Turn ignition switch ON.
4. Check the voltage between cooling fan control module harness connector and ground.

Cooling fan control module		Ground	Voltage
Connector	Terminal		
E37	3	Ground	Battery voltage

Is the inspection result normal?

- YES >> GO TO 2.
NO >> GO TO 7.

2. CHECK COOLING FAN CONTROL MODULE GROUND CIRCUIT

1. Turn ignition switch OFF.
2. Check the continuity between cooling fan control module harness connector and ground.

Cooling fan control module		Ground	Continuity
Connector	Terminal		
E37	1	Ground	Existed

3. Also check harness for short to power.

Is the inspection result normal?

- YES >> GO TO 3.
NO >> Repair open circuit or short to power in harness or connectors.

COOLING FAN

[VQ37VHR]

< DTC/CIRCUIT DIAGNOSIS >

3.CHECK IPDM E/R GROUND CIRCUIT

1. Disconnect IPDM E/R harness connectors E5, E6.
2. Check the continuity between IPDM E/R harness connector and ground.

IPDM E/R		Ground	Continuity
Connector	Terminal		
E5	12	Ground	Existed
E6	41		

3. Also check harness for short to power.

Is the inspection result normal?

YES >> GO TO 4.

NO >> Repair open circuit or short to power in harness or connectors.

4.CHECK COOLING FAN CONTROL SIGNAL CIRCUIT

1. Disconnect IPDM E/R harness connector E9.
2. Check the continuity between IPDM E/R harness connector and cooling fan control module harness connector.

IPDM E/R		Cooling fan control module		Continuity
Connector	Terminal	Connector	Terminal	
E9	97	E37	2	Existed

3. Also check harness for short to ground and short to power.

Is the inspection result normal?

YES >> GO TO 5.

NO >> Repair open circuit, short to ground or short to power in harness or connectors.

5.CHECK COOLING FAN CONTROL MODULE OUTPUT SIGNAL CIRCUIT

1. Reconnect all harness connectors disconnected.
2. Disconnect cooling fan control module harness connectors E301, E302.
3. Turn ignition switch ON.
4. Check the voltage between cooling fan control module harness connector and ground.

Cooling fan control module		Ground	Voltage
Connector	Terminal		
—	4	Ground	Battery voltage
—	6		

Is the inspection result normal?

YES >> GO TO 6.

NO >> Replace cooling fan control module.

6.CHECK COOLING FAN MOTORS -1 AND -2

Refer to [EC-488. "Component Inspection \(Cooling Fan Motor\)".](#)

Is the inspection result normal?

YES >> GO TO 11.

NO >> Replace cooling fan motor.

7.CHECK COOLING FAN CONTROL MODULE POWER SUPPLY CIRCUIT-II

1. Turn ignition switch OFF.
2. Disconnect cooling fan relay.
3. Turn ignition switch ON.
4. Check the voltage between cooling fan relay harness connector and ground.

COOLING FAN

< DTC/CIRCUIT DIAGNOSIS >

[VQ37VHR]

Cooling fan relay		Ground	Voltage
Connector	Terminal		
E17	2	Ground	Battery voltage
	3		

Is the inspection result normal?

- YES >> GO TO 9.
- NO >> GO TO 8.

8. DETECT MALFUNCTIONING PART

Check the following.

- 10A fuse (No. 42)
- IPDM E/R harness connector E7
- 50A fusible link (letter F)
- Harness for open or short between cooling fan relay and fuse
- Harness for open or short between cooling fan relay and battery

>> Repair open circuit, short to ground or short to power in harness or connectors.

9. CHECK COOLING FAN CONTROL MODULE POWER SUPPLY CIRCUIT-III

1. Turn ignition switch OFF.
2. Disconnect IPDM E/R harness connector E6.
3. Check the continuity between cooling fan relay harness connector and IPDM E/R harness connector.

Cooling fan relay		IPDM E/R		Continuity
Connector	Terminal	Connector	Terminal	
E17	1	E6	42	Existed

4. Check the continuity between cooling fan relay harness connector and cooling fan control module harness connector.

Cooling fan relay		Cooling fan control module		Continuity
Connector	Terminal	Connector	Terminal	
E17	5	E37	3	Existed

5. Also check harness for short to ground and short to power.

Is the inspection result normal?

- YES >> GO TO 10.
- NO >> Repair open circuit, short to ground or short to power in harness or connectors.

10. CHECK COOLING FAN RELAY

Refer to [EC-489, "Component Inspection \(Cooling Fan Relay\)"](#).

Is the inspection result normal?

- YES >> GO TO 11.
- NO >> Replace cooling fan relay.

11. CHECK INTERMITTENT INCIDENT

Perform [GI-36, "Intermittent Incident"](#).

Is the inspection result normal?

- YES >> Replace IPDM E/R.
- NO >> Repair or replace harness connectors.

Component Inspection (Cooling Fan Motor)

INFOID:000000005152065

1. CHECK COOLING FAN MOTOR

1. Turn ignition switch OFF.

COOLING FAN

[VQ37VHR]

< DTC/CIRCUIT DIAGNOSIS >

2. Disconnect cooling fan control module harness connectors E301, E302.
3. Supply cooling fan control module terminals with battery voltage and check operation.

Cooling fan control module				Operation
Motor	Connector	Terminal		
		(+)	(-)	
1	E301	4	5	Cooling fan operates.
2	E302	6	7	

Is the inspection result normal?

- YES >> INSPECTION END
 NO >> Replace cooling fan motor.

Component Inspection (Cooling Fan Relay)

INFOID:000000005152066

1. CHECK COOLING FAN RELAY

1. Turn ignition switch OFF.
2. Remove cooling fan relay.
3. Check the continuity between cooling fan relay terminals under the following conditions.

Terminals	Conditions	Continuity
3 and 5	12 V direct current supply between terminals 1 and 2	Existed
	No current supply	Not existed

Is the inspection result normal?

- YES >> INSPECTION END
 NO >> Replace cooling fan relay.

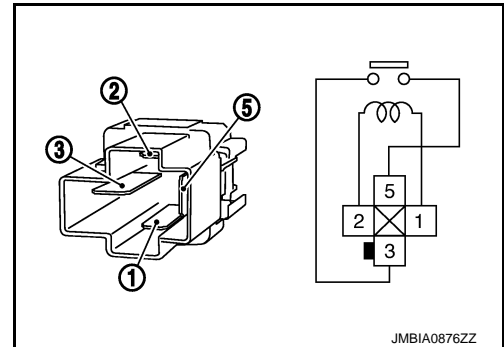

JMBIA0876ZZ

ELECTRICAL LOAD SIGNAL

< DTC/CIRCUIT DIAGNOSIS >

[VQ37VHR]

ELECTRICAL LOAD SIGNAL

Description

INFOID:000000005152067

The electrical load signal (Headlamp switch signal, rear window defogger switch signal, etc.) is transferred via the CAN communication line.

Component Function Check

INFOID:000000005152068

1. CHECK REAR WINDOW DEFOGGER SWITCH FUNCTION

1. Turn ignition switch ON.
2. Connect CONSULT-III and select "DATA MONITOR" mode.
3. Select "LOAD SIGNAL" and check indication under the following conditions.

Monitor item	Condition	Indication	
LOAD SIGNAL	Rear window defogger switch	ON	ON
		OFF	OFF

Is the inspection result normal?

YES >> GO TO 2.

NO >> Go to [EC-490, "Diagnosis Procedure"](#).

2. CHECK LIGHTING SWITCH FUNCTION

Check "LOAD SIGNAL" indication under the following conditions.

Monitor item	Condition	Indication	
LOAD SIGNAL	Lighting switch	ON at 2nd position	ON
		OFF	OFF

Is the inspection result normal?

YES >> GO TO 3.

NO >> Go to [EC-490, "Diagnosis Procedure"](#).

3. CHECK HEATER FAN CONTROL SWITCH FUNCTION

Select "HEATER FAN SW" and check indication under the following conditions.

Monitor item	Condition	Indication	
HEATER FAN SW	Heater fan control switch	ON	ON
		OFF	OFF

Is the inspection result normal?

YES >> INSPECTION END

NO >> Go to [EC-490, "Diagnosis Procedure"](#).

Diagnosis Procedure

INFOID:000000005152069

1. INSPECTION START

Confirm the malfunctioning circuit (rear window defogger, headlamp or heater fan). Refer to [EC-490, "Component Function Check"](#).

Which circuit is related to the incident?

Rear window defogger>>GO TO 2.

Headlamp>>GO TO 3.

Heater fan>>GO TO 4.

2. CHECK REAR WINDOW DEFOGGER SYSTEM

Refer to [DEF-3, "Work Flow"](#).

ELECTRICAL LOAD SIGNAL

< DTC/CIRCUIT DIAGNOSIS >

[VQ37VHR]

>> INSPECTION END

3.CHECK HEADLAMP SYSTEM

Refer to [EXL-5, "Work Flow"](#).

>> INSPECTION END

4.CHECK HEATER FAN CONTROL SYSTEM

Refer to [HAC-4, "Work Flow"](#).

>> INSPECTION END

A

EC

C

D

E

F

G

H

I

J

K

L

M

N

O

P

FUEL INJECTOR

Description

INFOID:000000005152070

The fuel injector is a small, precise solenoid valve. When the ECM supplies a ground to the fuel injector circuit, the coil in the fuel injector is energized. The energized coil pulls the ball valve back and allows fuel to flow through the fuel injector into the intake manifold. The amount of fuel injected depends upon the injection pulse duration. Pulse duration is the length of time the fuel injector remains open. The ECM controls the injection pulse duration based on engine fuel needs.

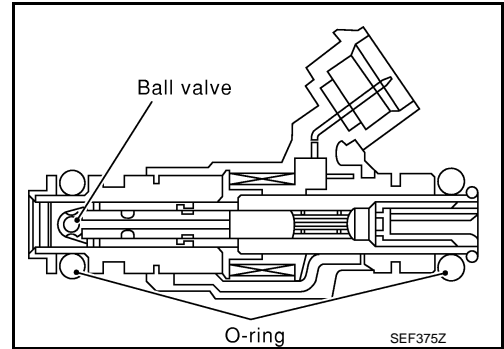

Component Function Check

INFOID:000000005152071

1.INSPECTION START

Turn ignition switch to START.

Are any cylinders ignited?

YES >> GO TO 2.

NO >> Go to [EC-492, "Diagnosis Procedure"](#).

2.CHECK FUEL INJECTOR FUNCTION

Ⓜ With CONSULT-III

1. Start engine.
2. Perform "POWER BALANCE" in "ACTIVE TEST" mode with CONSULT-III.
3. Make sure that each circuit produces a momentary engine speed drop.

ⓧ Without CONSULT-III

1. Start engine.
2. Listen to each fuel injector operating sound.

Clicking sound should be heard.

Is the inspection result normal?

YES >> INSPECTION END

NO >> Go to [EC-492, "Diagnosis Procedure"](#).

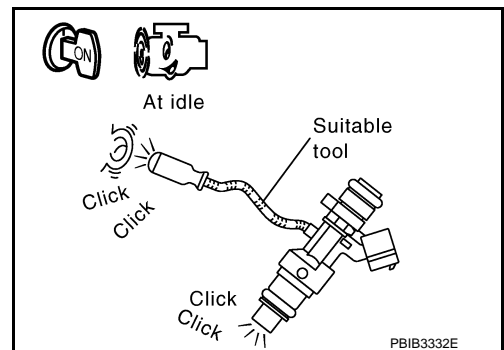

Diagnosis Procedure

INFOID:000000005152072

1.CHECK FUEL INJECTOR POWER SUPPLY CIRCUIT

1. Turn ignition switch OFF.
2. Disconnect fuel injector harness connector.
3. Turn ignition switch ON.
4. Check the voltage between fuel injector harness connector and ground.

FUEL INJECTOR

[VQ37VHR]

< DTC/CIRCUIT DIAGNOSIS >

Fuel injector			Ground	Voltage
Cylinder	Connector	Terminal		
1	F121	1	Ground	Battery voltage
2	F122	1		
3	F123	1		
4	F124	1		
5	F125	1		
6	F126	1		

Is the inspection result normal?

YES >> GO TO 3.

NO >> GO TO 2.

2.DETECT MALFUNCTIONING PART

Check the following.

- Harness connectors E3, F1
- Harness connectors F10, F120
- IPDM E/R harness connector E7
- 10 A fuse (No. 44)
- Harness for open or short between fuel injector and fuse

>> Repair open circuit, short to ground or short to power in harness or connectors.

3.CHECK FUEL INJECTOR OUTPUT SIGNAL CIRCUIT FOR OPEN AND SHORT

1. Turn ignition switch OFF.
2. Disconnect ECM harness connector.
3. Check the continuity between fuel injector harness connector and ECM harness connector.

Fuel injector			ECM		Continuity
Cylinder	Connector	Terminal	Connector	Terminal	
1	F121	2	F102	89	Existed
2	F122	2		85	
3	F123	2		81	
4	F124	2		90	
5	F125	2		86	
6	F126	2		82	

4. Also check harness for short to ground and short to power.

Is the inspection result normal?

YES >> GO TO 5.

NO >> GO TO 4

4.DETECT MALFUNCTIONING PART

Check the following.

- Harness connectors F10, F120
- Harness for open or short between fuel injector and ECM

>> Repair open circuit, short to ground or short to power in harness or connectors.

5.CHECK FUEL INJECTOR

Refer to [EC-494. "Component Inspection"](#).

Is the inspection result normal?

YES >> GO TO 6.

FUEL INJECTOR

[VQ37VHR]

< DTC/CIRCUIT DIAGNOSIS >

NO >> Replace malfunctioning fuel injector.

6.CHECK INTERMITTENT INCIDENT

Refer to [GI-36, "Intermittent Incident"](#).

Is the inspection result normal?

YES >> Replace IPDM E/R.

NO >> Repair open circuit, short to ground or short to power in harness or connectors.

Component Inspection

INFOID:000000005152073

1.CHECK FUEL INJECTOR

1. Turn ignition switch OFF.
2. Disconnect fuel injector harness connector.
3. Check resistance between fuel injector terminals as follows.

Terminals	Resistance (Ω)
1 and 2	11.1 - 14.3 [at 10 - 60°C (60 - 140°F)]

Is the inspection result normal?

YES >> INSPECTION END

NO >> Replace malfunctioning fuel injector.

FUEL PUMP

< DTC/CIRCUIT DIAGNOSIS >

[VQ37VHR]

FUEL PUMP

Description

INFOID:000000005152074

Sensor	Input signal to ECM	ECM Function	Actuator
Crankshaft position sensor (POS) Camshaft position sensor (PHASE)	Engine speed*	Fuel pump control	Fuel pump relay ↓ Fuel pump
Battery	Battery voltage*		

*: ECM determines the start signal status by the signals of engine speed and battery voltage.

The ECM activates the fuel pump for several seconds after the ignition switch is turned ON to improve engine startability. If the ECM receives a engine speed signal from the camshaft position sensor (PHASE), it knows that the engine is rotating, and causes the pump to operate. If the engine speed signal is not received when the ignition switch is ON, the engine stalls. The ECM stops pump operation and prevents battery discharging, thereby improving safety. The ECM does not directly drive the fuel pump. It controls the ON/OFF fuel pump relay, which in turn controls the fuel pump.

Condition	Fuel pump operation
Ignition switch is turned to ON.	Operates for 1 second.
Engine running and cranking	Operates.
When engine is stopped	Stops in 1.5 seconds.
Except as shown above	Stops.

Component Function Check

INFOID:000000005152075

1.CHECK FUEL PUMP FUNCTION

1. Turn ignition switch ON.
2. Pinch fuel feed hose (1) with two fingers.

Fuel pressure pulsation should be felt on the fuel feed hose for 1 second after ignition switch is turned ON.

Is the inspection result normal?

- YES >> INSPECTION END
NO >> [EC-495, "Diagnosis Procedure"](#).

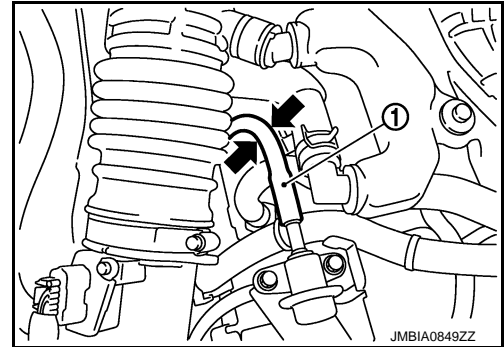

Diagnosis Procedure

INFOID:000000005152076

1.CHECK FUEL PUMP POWER SUPPLY CIRCUIT-I

1. Turn ignition switch OFF.
2. Disconnect ECM harness connector.
3. Turn ignition switch ON.
4. Check the voltage between ECM harness connector and ground.

ECM		Ground	Voltage
Connector	Terminal		
F101	22	Ground	Battery voltage

Is the inspection result normal?

- YES >> GO TO 4.
NO >> GO TO 2.

2.CHECK FUEL PUMP POWER SUPPLY CIRCUIT-II

FUEL PUMP

[VQ37VHR]

< DTC/CIRCUIT DIAGNOSIS >

Check the voltage between IPDM E/R harness connector and ground.

IPDM E/R		Ground	Voltage
Connector	Terminal		
E7	77	Ground	Battery voltage

Is the inspection result normal?

YES >> GO TO 3.

NO >> GO TO 10.

3. DETECT MALFUNCTIONING PART

Check the following.

- Harness connectors E3, F1
- Harness for open or short between IPDM E/R and ECM

>> Repair open circuit, short to ground or short to power in harness or connectors.

4. CHECK FUEL PUMP POWER SUPPLY CIRCUIT-III

1. Turn ignition switch OFF.
2. Reconnect all harness connectors disconnected.
3. Disconnect "fuel level sensor unit and fuel pump" harness connector.
4. Turn ignition switch ON.
5. Check the voltage between "fuel level sensor unit and fuel pump" harness connector and ground.

Fuel level sensor unit and fuel pump		Ground	Voltage
Connector	Terminal		
B22	1	Ground	Battery voltage should exist for 1 second after ignition switch is turned ON.

Is the inspection result normal?

YES >> GO TO 8.

NO >> GO TO 5.

5. CHECK 15A FUSE

1. Turn ignition switch OFF.
2. Disconnect 15A fuse (No. 41) from IPDM E/R.
3. Check 15 A fuse.

Is the inspection result normal?

YES >> GO TO 6.

NO >> Replace fuse.

6. CHECK FUEL PUMP POWER SUPPLY CIRCUIT-IV

1. Disconnect IPDM E/R harness connector E5.
2. Check the continuity between IPDM E/R harness connector and "fuel level sensor unit and fuel pump" harness connector.

IPDM E/R		Fuel level sensor unit and fuel pump		Continuity
Connector	Terminal	Connector	Terminal	
E5	13	B22	1	Existed

3. Also check harness for short to ground and short to power.

Is the inspection result normal?

YES >> GO TO 10.

NO >> GO TO 7.

7. DETECT MALFUNCTIONING PART

FUEL PUMP

[VQ37VHR]

< DTC/CIRCUIT DIAGNOSIS >

Check the following.

- Harness connectors E117, B9
- IPDM E/R harness connector E5
- Harness for open or short between IPDM E/R and “fuel level sensor unit and fuel pump”

>> Repair open circuit, short to ground or short to power in harness or connectors.

8.CHECK FUEL PUMP GROUND CIRCUIT

1. Turn ignition switch OFF.
2. Check the continuity between “fuel level sensor unit and fuel pump” harness connector and ground.

Fuel level sensor unit and fuel pump		Ground	Continuity
Connector	Terminal		
B22	3	Ground	Existed

3. Also check harness for short to power.

Is the inspection result normal?

YES >> GO TO 9.

NO >> Repair open circuit or short to power in harness or connectors.

9.CHECK FUEL PUMP

Refer to [EC-497, "Component Inspection"](#).

Is the inspection result normal?

YES >> GO TO 10.

NO >> Replace fuel pump.

10.CHECK INTERMITTENT INCIDENT

Refer to [GI-36, "Intermittent Incident"](#).

Is the inspection result normal?

YES >> Replace IPDM E/R.

NO >> Repair or replace harness or connectors.

Component Inspection

INFOID:000000005152077

1.CHECK FUEL PUMP

1. Turn ignition switch OFF.
2. Disconnect “fuel level sensor unit and fuel pump” harness connector.
3. Check resistance between “fuel level sensor unit and fuel pump” terminals as follows.

Terminals	Resistance (Ω)
1 and 3	0.2 - 5.0 [at 25°C (77°F)]

Is the inspection result normal?

YES >> INSPECTION END

NO >> Replace “fuel level sensor unit and fuel pump”

ICC BRAKE SWITCH

< DTC/CIRCUIT DIAGNOSIS >

[VQ37VHR]

ICC BRAKE SWITCH

Description

INFOID:000000005152078

When the brake pedal is depressed, ICC brake switch is turned OFF and stop lamp switch is turned ON. ECM detects the state of the brake pedal by those two types of input (ON/OFF signal). Refer to [CCS-17, "System Description"](#) for the ICC function.

Component Function Check

INFOID:000000005152079

1. CHECK ICC BRAKE SWITCH FUNCTION

With CONSULT-III

1. Turn ignition switch ON.
2. Select "BRAKE SW1" in "DATA MONITOR" mode with CONSULT-III.
3. Check "BRAKE SW1" indication under the following conditions.

Monitor item	Condition	Indication
BRAKE SW1	Brake pedal (A/T) Brake pedal or clutch pedal (M/T)	Slightly depressed OFF
	Brake pedal (A/T) Brake pedal and clutch pedal (M/T)	Fully released ON

Without CONSULT-III

1. Turn ignition switch ON.
2. Check the voltage between ECM harness connector terminals as per the following.

Connector	ECM		Condition	Voltage (V)
	+	-		
	Terminal	Terminal		
M107	126 (ICC brake switch signal)	128	Brake pedal (A/T) Brake pedal or clutch pedal (M/T)	Slightly depressed Approx. 0
			Brake pedal (A/T) Brake pedal and clutch pedal (M/T)	Fully released Battery voltage

Is the inspection result normal?

- YES >> INSPECTION END
NO >> Go to [EC-498, "Diagnosis Procedure"](#).

Diagnosis Procedure

INFOID:000000005152080

1. INSPECTION START

Check which type of transmission the vehicle is equipped with.

Which type of transmission?

- A/T >> GO TO 2.
M/T >> GO TO 7.

2. CHECK ICC BRAKE SWITCH POWER SUPPLY CIRCUIT

1. Turn ignition switch OFF.
2. Disconnect ICC brake switch harness connector.
3. Turn ignition switch ON.
4. Check the voltage between ICC brake switch harness connector and ground.

ICC brake switch		Ground	Voltage
Connector	Terminal		
E114	1	Ground	Battery voltage

ICC BRAKE SWITCH

[VQ37VHR]

< DTC/CIRCUIT DIAGNOSIS >

Is the inspection result normal?

- YES >> GO TO 4.
- NO >> GO TO 3.

3. DETECT MALFUNCTIONING PART

Check the following.

- Fuse block (J/B) connector E103
- 10A fuse (No. 3)
- Harness for open or short between ICC brake switch and fuse

>> Repair open circuit or short to ground in harness or connectors.

4. CHECK ICC BRAKE SWITCH INPUT SIGNAL CIRCUIT FOR OPEN AND SHORT

1. Turn ignition switch OFF.
2. Disconnect ECM harness connector.
3. Check the continuity between ICC brake switch harness connector and ECM harness connector.

ICC brake switch		ECM		Continuity
Connector	Terminal	Connector	Terminal	
E114	2	M107	126	Existed

4. Also check harness for short to ground and short to power.

Is the inspection result normal?

- YES >> GO TO 6.
- NO >> GO TO 5.

5. DETECT MALFUNCTIONING PART

Check the following.

- Harness connectors E106, M6
- Harness for open or short between ICC brake switch and ECM

>> Repair open circuit, short to ground or short to power in harness or connectors.

6. CHECK ICC BRAKE SWITCH

Refer to [EC-501, "Component Inspection \(ICC Brake Switch\)"](#).

Is the inspection result normal?

- YES >> GO TO 15.
- NO >> Replace ICC brake switch.

7. CHECK ICC CLUTCH SWITCH CIRCUIT

1. Turn ignition switch OFF.
2. Disconnect ICC brake switch harness connector.
3. Turn ignition switch ON.
4. Check the voltage between ICC brake switch harness connector and ground.

ICC brake switch		Ground	Condition	Voltage (V)	
Connector	Terminal				
E114	1	Ground	Clutch pedal	Slightly depressed	Approx. 0
				Fully released	Battery voltage

Is the inspection result normal?

- YES >> GO TO 12.
- NO >> GO TO 8.

8. CHECK ICC BRAKE SWITCH POWER SUPPLY CIRCUIT

1. Turn ignition switch OFF.
2. Disconnect ICC clutch switch harness connector.

ICC BRAKE SWITCH

[VQ37VHR]

< DTC/CIRCUIT DIAGNOSIS >

3. Turn ignition switch ON.
4. Check the voltage between ICC clutch switch harness connector and ground.

ICC clutch switch		Ground	Voltage
Connector	Terminal		
E113	1	Ground	Battery voltage

Is the inspection result normal?

- YES >> GO TO 10.
NO >> GO TO 9.

9.DETECT MALFUNCTIONING PART

Check the following.

- Fuse block (J/B) connector E103
- 10 A fuse (No. 3)
- Harness for open or short between ICC clutch switch and fuse

>> Repair open circuit or short to ground in harness or connectors.

10.CHECK ICC BRAKE SWITCH INPUT SIGNAL CIRCUIT FOR OPEN AND SHORT-I

1. Turn ignition switch OFF.
2. Check the continuity between ICC clutch switch harness connector and ICC brake switch harness connector.

ICC clutch switch		ICC brake switch		Continuity
Connector	Terminal	Connector	Terminal	
E113	2	E114	1	Existed

3. Also check harness for short to ground and short to power.

Is the inspection result normal?

- YES >> GO TO 11.
NO >> Repair open circuit, short to ground or short to power in harness or connectors.

11.CHECK ICC CLUTCH SWITCH

Refer to [EC-501, "Component Inspection \(ICC Clutch Switch\)"](#).

Is the inspection result normal?

- YES >> GO TO 15.
NO >> Replace ICC clutch switch.

12.CHECK ICC BRAKE SWITCH INPUT SIGNAL CIRCUIT FOR OPEN AND SHORT-II

1. Turn ignition switch OFF.
2. Disconnect ECM harness connector.
3. Check the continuity between ICC brake switch harness connector and ECM harness connector.

ICC brake switch		ECM		Continuity
Connector	Terminal	Connector	Terminal	
E114	2	M107	126	Existed

4. Also check harness for short to ground and short to power.

Is the inspection result normal?

- YES >> GO TO 14.
NO >> GO TO 13.

13.DETECT MALFUNCTIONING PART

Check the following.

- Harness connectors E106, M6
- Harness for open or short between ICC brake switch and ECM

>> Repair open circuit, short to ground or short to power in harness or connectors.

14. CHECK ICC BRAKE SWITCH

Refer to [EC-501, "Component Inspection \(ICC Brake Switch\)"](#).

Is the inspection result normal?

- YES >> GO TO 15.
- NO >> Replace ICC brake switch.

15. CHECK INTERMITTENT INCIDENT

Refer to [GI-36, "Intermittent Incident"](#).

>> INSPECTION END

Component Inspection (ICC Brake Switch)

INFOID:000000005152081

1. CHECK ICC BRAKE SWITCH-I

1. Turn ignition switch OFF.
2. Disconnect ICC brake switch harness connector.
3. Check the continuity between ICC brake switch terminals under the following conditions.

Terminals	Condition	Continuity
1 and 2	Brake pedal	Fully released Existed
		Slightly depressed Not existed

Is the inspection result normal?

- YES >> INSPECTION END
- NO >> GO TO 2.

2. CHECK ICC BRAKE SWITCH-II

1. Adjust ICC brake switch installation. Refer to [BR-8, "Inspection and Adjustment"](#).
2. Check the continuity between ICC brake switch terminals under the following conditions.

Terminals	Condition	Continuity
1 and 2	Brake pedal	Fully released Existed
		Slightly depressed Not existed

Is the inspection result normal?

- YES >> INSPECTION END
- NO >> Replace ICC brake switch.

Component Inspection (ICC Clutch Switch)

INFOID:000000005152082

1. CHECK ICC CLUTCH SWITCH-I

1. Turn ignition switch OFF.
2. Disconnect ICC clutch switch harness connector.
3. Check the continuity between ICC clutch switch terminals under the following conditions.

Terminals	Condition	Continuity
1 and 2	Clutch pedal	Fully released Existed
		Slightly depressed Not existed

Is the inspection result normal?

- YES >> INSPECTION END
- NO >> GO TO 2.

2. CHECK ICC CLUTCH SWITCH-II

ICC BRAKE SWITCH

[VQ37VHR]

< DTC/CIRCUIT DIAGNOSIS >

1. Adjust ICC clutch switch installation. Refer to [CL-6. "Inspection and Adjustment"](#).
2. Check the continuity between ICC clutch switch terminals under the following conditions.

Terminals	Condition		Continuity
1 and 2	Clutch pedal	Fully released	Existed
		Slightly depressed	Not existed

Is the inspection result normal?

- YES >> INSPECTION END
NO >> Replace ICC clutch switch.

IGNITION SIGNAL

[VQ37VHR]

< DTC/CIRCUIT DIAGNOSIS >

IGNITION SIGNAL

Description

INFOID:000000005152083

The ignition signal from the ECM is sent to and amplified by the power transistor. The power transistor turns ON and OFF the ignition coil primary circuit. This ON/OFF operation induces the proper high voltage in the coil secondary circuit.

Component Function Check

INFOID:000000005152084

1. INSPECTION START

Turn ignition switch OFF, and restart engine.

Does the engine start?

YES-1 >> With CONSULT-III: GO TO 2.

YES-2 >> Without CONSULT-III: GO TO 3.

No >> Go to [EC-503, "Diagnosis Procedure"](#).

2. CHECK IGNITION SIGNAL FUNCTION

With CONSULT-III

1. Perform "POWER BALANCE" in "ACTIVE TEST" mode with CONSULT-III.

2. Make sure that each circuit produces a momentary engine speed drop.

Is the inspection result normal?

YES >> INSPECTION END

NO >> Go to [EC-503, "Diagnosis Procedure"](#).

3. CHECK IGNITION SIGNAL FUNCTION

Without CONSULT-III

1. Let engine idle.

2. Read the voltage signal between ECM harness connector terminals under the following conditions with an oscilloscope.

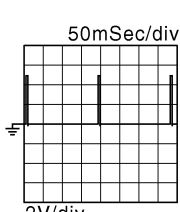
ECM				Voltage signal
+		-		
Connector	Terminal	Connector	Terminal	
F101	11	M107	128	
	12			
	15			
	16			
	19			
	20			

NOTE:

The pulse cycle changes depending on rpm at idle.

Is the inspection result normal?

YES >> INSPECTION END

NO >> Go to [EC-503, "Diagnosis Procedure"](#).

Diagnosis Procedure

INFOID:000000005152085

1. CHECK IGNITION COIL POWER SUPPLY CIRCUIT-I

1. Turn ignition switch OFF, wait at least 10 seconds and then turn it ON.

2. Check the voltage between ECM harness connector terminals as per the following.

IGNITION SIGNAL

< DTC/CIRCUIT DIAGNOSIS >

[VQ37VHR]

ECM			Voltage
Connector	+	-	
	Terminal	Terminal	
M107	125	128	Battery voltage

Is the inspection result normal?

YES >> GO TO 2.

NO >> Go to [EC-140. "Diagnosis Procedure"](#).

2.CHECK IGNITION COIL POWER SUPPLY CIRCUIT-II

1. Turn ignition switch OFF.
2. Disconnect condenser harness connector.
3. Turn ignition switch ON.
4. Check the voltage between condenser harness connector and ground.

Condenser		Ground	Voltage
Connector	Terminal		
F8	1	Ground	Battery voltage

Is the inspection result normal?

YES >> GO TO 5.

NO >> GO TO 3.

3.CHECK IGNITION COIL POWER SUPPLY CIRCUIT-III

1. Turn ignition switch OFF.
2. Disconnect IPDM E/R harness connector E7.
3. Check the continuity between IPDM E/R harness connector and condenser harness connector.

IPDM E/R		Condenser		Continuity
Connector	Terminal	Connector	Terminal	
E7	53	F8	1	Existed

4. Also check harness for short to ground and short to power.

Is the inspection result normal?

YES >> Go to [EC-140. "Diagnosis Procedure"](#).

NO >> GO TO 4.

4.DETECT MALFUNCTIONING PART

Check the following.

- Harness connectors E3, F1
- Harness for open or short between IPDM E/R and condenser

>> Repair open circuit, short to ground or short to power in harness or connectors.

5.CHECK CONDENSER GROUND CIRCUIT FOR OPEN AND SHORT

1. Turn ignition switch OFF.
2. Check the continuity between condenser harness connector and ground.

Condenser		Ground	Continuity
Connector	Terminal		
F8	2	Ground	Existed

3. Also check harness for short to power.

Is the inspection result normal?

YES >> GO TO 6.

NO >> Repair open circuit or short to power in harness or connectors.

IGNITION SIGNAL

< DTC/CIRCUIT DIAGNOSIS >

[VQ37VHR]

6. CHECK CONDENSER

Refer to [EC-507. "Component Inspection \(Condenser\)"](#)

Is the inspection result normal?

YES >> GO TO 7.

NO >> Replace condenser.

7. CHECK IGNITION COIL POWER SUPPLY CIRCUIT-IV

1. Reconnect all harness connectors disconnected.
2. Disconnect ignition coil harness connector.
3. Turn ignition switch ON.
4. Check the voltage between ignition coil harness connector and ground.

Ignition coil			Ground	Voltage
Cylinder	Connector	Terminal		
1	F11	3	Ground	Battery voltage
2	F12	3		
3	F13	3		
4	F14	3		
5	F15	3		
6	F16	3		

Is the inspection result normal?

YES >> GO TO 9.

NO >> GO TO 8.

8. DETECT MALFUNCTIONING PART

Check the following.

- Harness connector F1
- Harness for open or short between ignition coil and harness connector F1

>> Repair or replace harness or connectors.

9. CHECK IGNITION COIL GROUND CIRCUIT FOR OPEN AND SHORT

1. Turn ignition switch OFF.
2. Check the continuity between ignition coil harness connector and ground.

Ignition coil			Ground	Continuity
Cylinder	Connector	Terminal		
1	F11	2	Ground	Existed
2	F12	2		
3	F13	2		
4	F14	2		
5	F15	2		
6	F16	2		

3. Also check harness for short to power.

Is the inspection result normal?

YES >> GO TO 10.

NO >> Repair open circuit or short to power in harness or connectors.

10. CHECK IGNITION COIL OUTPUT SIGNAL CIRCUIT FOR OPEN AND SHORT

1. Disconnect ECM harness connector.
2. Check the continuity between ignition coil harness connector and ECM harness connector.

IGNITION SIGNAL

< DTC/CIRCUIT DIAGNOSIS >

[VQ37VHR]

Ignition coil			ECM		Continuity
Cylinder	Connector	Terminal	Connector	Terminal	
1	F11	1	F101	20	Existed
2	F12	1		16	
3	F13	1		12	
4	F14	1		11	
5	F15	1		15	
6	F16	1		19	

3. Also check harness for short to ground and short to power.

Is the inspection result normal?

YES >> GO TO 11.

NO >> Repair open circuit, short to ground or short to power in harness or connectors.

11.CHECK IGNITION COIL WITH POWER TRANSISTOR

Refer to [EC-506, "Component Inspection \(Ignition Coil with Power Transistor\)"](#).

Is the inspection result normal?

YES >> GO TO 12.

NO >> Replace malfunctioning ignition coil with power transistor.

12.CHECK INTERMITTENT INCIDENT

Refer to [GI-36, "Intermittent Incident"](#).

>> INSPECTION END

Component Inspection (Ignition Coil with Power Transistor)

INFOID:000000005152086

1.CHECK IGNITION COIL WITH POWER TRANSISTOR-I

1. Turn ignition switch OFF.
2. Disconnect ignition coil harness connector.
3. Check resistance between ignition coil terminals as per the following.

Terminals	Resistance (Ω) [at 25°C (77°F)]
1 and 2	Except 0 or ∞
1 and 3	Except 0
2 and 3	

Is the inspection result normal?

YES >> GO TO 2.

NO >> Replace malfunctioning ignition coil with power transistor.

2.CHECK IGNITION COIL WITH POWER TRANSISTOR-II

CAUTION:

Perform the following procedure in a place where with no combustible objects and good ventilation.

1. Turn ignition switch OFF.
2. Reconnect all harness connectors disconnected.

IGNITION SIGNAL

[VQ37VHR]

< DTC/CIRCUIT DIAGNOSIS >

3. Remove fuel pump fuse (1) in IPDM E/R (2) to release fuel pressure.
NOTE:
 Do not use CONSULT-III to release fuel pressure, or fuel pressure applies again during the following procedure.
4. Start engine.
5. After engine stalls, crank it two or three times to release all fuel pressure.
6. Turn ignition switch OFF.
7. Remove all ignition coil harness connectors to avoid the electrical discharge from the ignition coils.
8. Remove ignition coil and spark plug of the cylinder to be checked.
9. Crank engine for 5 seconds or more to remove combustion gas in the cylinder.
10. Connect spark plug and harness connector to ignition coil.
11. Fix ignition coil using a rope etc. with gap of 13 - 17 mm (0.52 - 0.66 in) between the edge of the spark plug and grounded metal portion as shown in the figure.
12. Crank engine for about three seconds, and check whether spark is generated between the spark plug and the grounded metal portion.

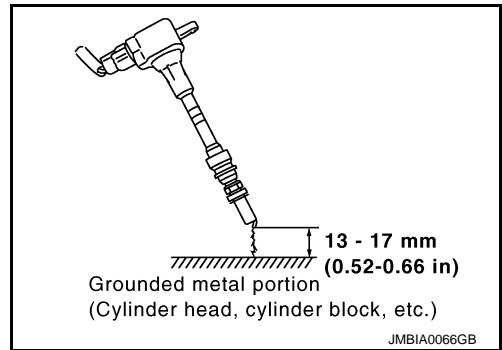
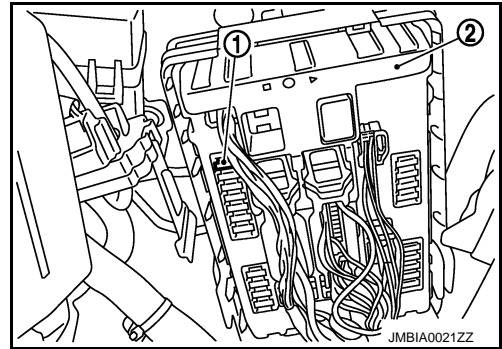

Spark should be generated.

CAUTION:

- During the operation, always stay 0.5 m (1.6 ft) or more away from the spark plug and ignition coil. Be careful not to get an electrical shock while checking, because the electrical discharge voltage becomes 20 kV or more.
- It might damage the ignition coil if the gap of more than 17 mm (0.66 in) is made.

NOTE:

When the gap is less than 13 mm (0.52 in), spark might be generated even if the coil is malfunctioning.

Is the inspection result normal?

- YES >> INSPECTION END
 NO >> Replace malfunctioning ignition coil with power transistor.

Component Inspection (Condenser)

INFOID:000000005152087

1. CHECK CONDENSER

1. Turn ignition switch OFF.
2. Disconnect condenser harness connector.
3. Check resistance between condenser terminals as per the following.

Terminals	Resistance (MΩ)
1 and 2	Above 1 [at 25°C (77°F)]

Is the inspection result normal?

- YES >> INSPECTION END
 NO >> Replace condenser.

MALFUNCTION INDICATOR LAMP

[VQ37VHR]

< DTC/CIRCUIT DIAGNOSIS >

MALFUNCTION INDICATOR LAMP

Description

INFOID:000000005152088

The Malfunction Indicator Lamp (MIL) is located on the combination meter.

The MIL will illuminate when the ignition switch is turned ON without the engine running. This is a bulb check.

When the engine is started, the MIL should turn off. If the MIL remains illuminated, the on board diagnostic system has detected an engine system malfunction.

For details, refer to [EC-107. "Diagnosis Description"](#).

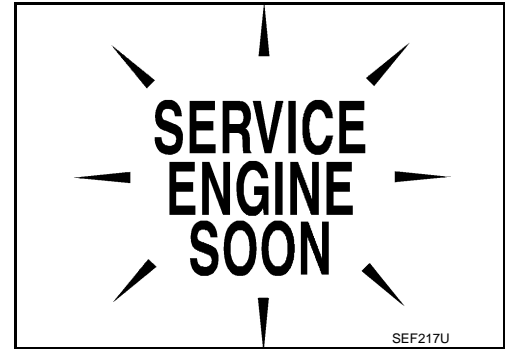

Component Function Check

INFOID:000000005152089

1. CHECK MIL FUNCTION

1. Turn ignition switch ON.
2. Make sure that MIL illuminates.

Is the inspection result normal?

- YES >> INSPECTION END
- NO >> Go to [EC-508. "Diagnosis Procedure"](#).

Diagnosis Procedure

INFOID:000000005152090

1. CHECK DTC

Check that DTC UXXXX is not displayed.

Is the inspection result normal?

- YES >> GO TO 2.
- NO >> Perform trouble diagnosis for DTC UXXXX.

2. CHECK DTC WITH "UNIFIED METER AND A/C AMP."

Refer to [MWI-37. "CONSULT-III Function \(METER/M&A\)"](#).

Is the inspection result normal?

- YES >> GO TO 3.
- NO >> Repair or replace.

3. CHECK INTERMITTENT INCIDENT

Refer to [GI-36. "Intermittent Incident"](#).

Is the inspection result normal?

- YES >> Replace combination meter.
- NO >> Repair or replace.

ON BOARD REFUELING VAPOR RECOVERY (ORVR)

< DTC/CIRCUIT DIAGNOSIS >

[VQ37VHR]

ON BOARD REFUELING VAPOR RECOVERY (ORVR)

Description

INFOID:000000005152091

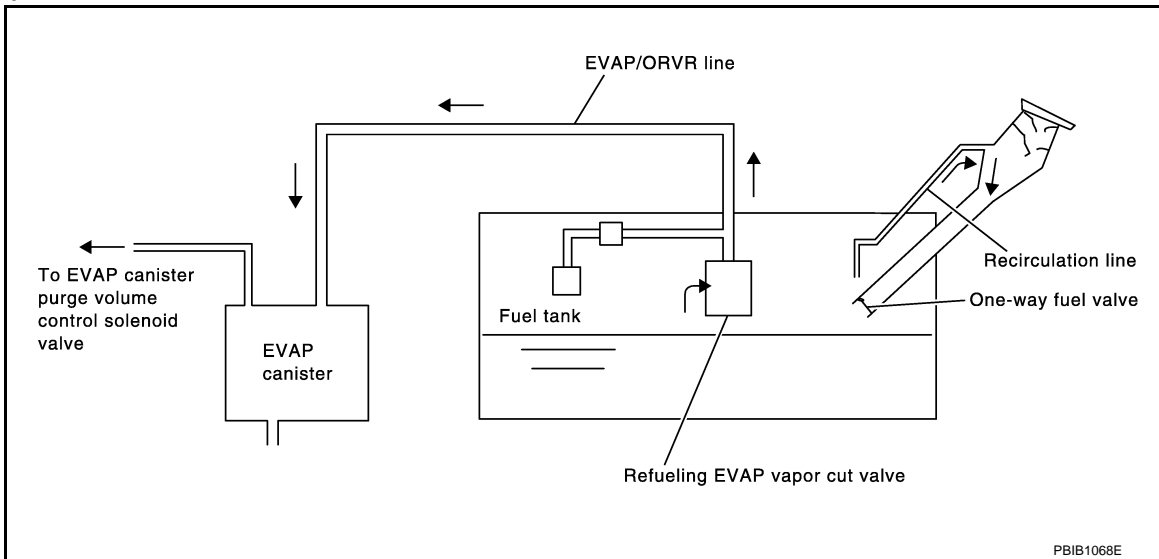

From the beginning of refueling, the air and vapor inside the fuel tank go through refueling EVAP vapor cut valve and EVAP/ORVR line to the EVAP canister. The vapor is absorbed by the EVAP canister and the air is released to the atmosphere.

When the refueling has reached the full level of the fuel tank, the refueling EVAP vapor cut valve is closed and refueling is stopped because of auto shut-off. The vapor which was absorbed by the EVAP canister is purged during driving.

WARNING:

When conducting inspections below, be sure to observe the following:

- Put a "CAUTION: FLAMMABLE" sign in workshop.
- Never smoke while servicing fuel system. Keep open flames and sparks away from work area.
- Always furnish the workshop with a CO₂ fire extinguisher.

CAUTION:

- Before removing fuel line parts, carry out the following procedures:
 - Put drained fuel in an explosion-proof container and put lid on securely.
 - Release fuel pressure from fuel line. Refer to [EC-607, "Inspection"](#).
 - Disconnect battery ground cable.
- Always replace O-ring when the fuel gauge retainer is removed.
- Never kink or twist hose and tube when they are installed.
- Never tighten hose and clamps excessively to avoid damaging hoses.
- After installation, run engine and check for fuel leaks at connections.
- Never attempt to top off the fuel tank after the fuel pump nozzle shuts off automatically. Continued refueling may cause fuel overflow, resulting in fuel spray and possibly a fire.

Component Function Check

INFOID:000000005152092

1. CHECK ORVR FUNCTION

Check whether the following symptoms are present.

- Fuel odor from EVAP canister is strong.
- Cannot refuel/Fuel odor from the fuel filler opening is strong while refueling.

Are any symptoms present?

- YES >> Go to [EC-509, "Diagnosis Procedure"](#).
- NO >> INSPECTION END

Diagnosis Procedure

INFOID:000000005152093

1. INSPECTION START

Check whether the following symptoms are present.

- A: Fuel odor from EVAP canister is strong.

ON BOARD REFUELING VAPOR RECOVERY (ORVR)

[VQ37VHR]

< DTC/CIRCUIT DIAGNOSIS >

B: Cannot refuel/Fuel odor from the fuel filler opening is strong while refueling.

Which symptom is present?

- A >> GO TO 2.
- B >> GO TO 7.

2.CHECK EVAP CANISTER

1. Remove EVAP canister with EVAP canister vent control valve and EVAP control system pressure sensor attached.
2. Weigh the EVAP canister with EVAP canister vent control valve and EVAP control system pressure sensor attached.

The weight should be less than 2.2 kg (4.9 lb).

Is the inspection result normal?

- YES >> GO TO 3.
- NO >> GO TO 4.

3.CHECK IF EVAP CANISTER IS SATURATED WITH WATER

Check if water will drain from EVAP canister (1).

- 2 : EVAP canister vent control valve

Does water drain from the EVAP canister?

- YES >> GO TO 4.
- NO >> GO TO 6.

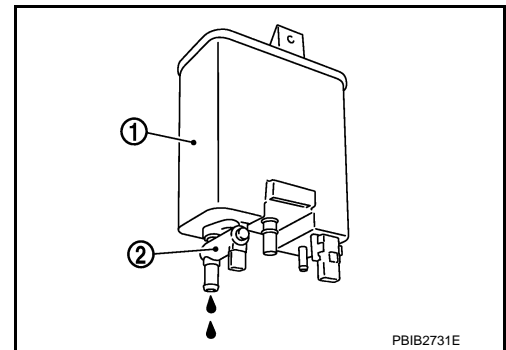

4.REPLACE EVAP CANISTER

Replace EVAP canister with a new one.

>> GO TO 5.

5.DETECT MALFUNCTIONING PART

Check the EVAP hose between EVAP canister and vehicle frame for clogging or poor connection.

>> Repair or replace EVAP hose.

6.CHECK REFUELING EVAP VAPOR CUT VALVE

Refer to [EC-512, "Component Inspection"](#).

Is the inspection result normal?

- YES >> INSPECTION END
- NO >> Replace refueling EVAP vapor cut valve with fuel tank.

7.CHECK EVAP CANISTER

1. Remove EVAP canister with EVAP canister vent control valve and EVAP control system pressure sensor attached.
2. Weigh the EVAP canister with EVAP canister vent control valve and EVAP control system pressure sensor attached.

The weight should be less than 2.2 kg (4.9 lb).

Is the inspection result normal?

- YES >> GO TO 8.
- NO >> GO TO 9.

8.CHECK IF EVAP CANISTER IS SATURATED WITH WATER

ON BOARD REFUELING VAPOR RECOVERY (ORVR)

[VQ37VHR]

< DTC/CIRCUIT DIAGNOSIS >

Check if water will drain from EVAP canister (1).

2 : EVAP canister vent control valve

Does water drain from the EVAP canister?

YES >> GO TO 9.

NO >> GO TO 11.

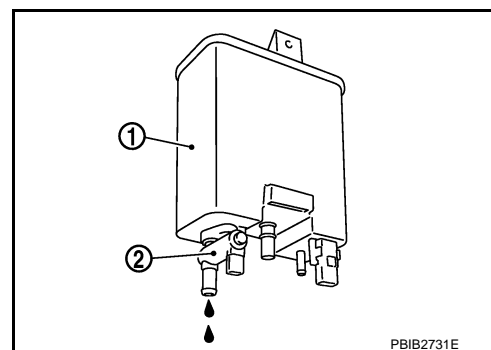

9.REPLACE EVAP CANISTER

Replace EVAP canister with a new one.

>> GO TO 10.

10.DETECT MALFUNCTIONING PART

Check the EVAP hose between EVAP canister and vehicle frame for clogging or poor connection.

>> Repair or replace EVAP hose.

11.CHECK VENT HOSES AND VENT TUBES

Check hoses and tubes between EVAP canister and refueling control valve for clogging, kinks, looseness and improper connection.

Is the inspection result normal?

YES >> GO TO 12.

NO >> Repair or replace hoses and tubes.

12.CHECK FILLER NECK TUBE

Check recirculation line for clogging, dents and cracks.

Is the inspection result normal?

YES >> GO TO 13.

NO >> Replace filler neck tube.

13.CHECK REFUELING EVAP VAPOR CUT VALVE

Refer to [EC-512. "Component Inspection"](#).

Is the inspection result normal?

YES >> GO TO 14.

NO >> Replace refueling EVAP vapor cut valve with fuel tank.

14.CHECK FUEL FILLER TUBE

Check filler neck tube and hose connected to the fuel tank for clogging, dents and cracks.

Is the inspection result normal?

YES >> GO TO 15.

NO >> Replace fuel filler tube.

15.CHECK ONE-WAY FUEL VALVE-I

Check one-way valve for clogging.

Is the inspection result normal?

YES >> GO TO 16.

NO >> Repair or replace one-way fuel valve with fuel tank.

16.CHECK ONE-WAY FUEL VALVE-II

1. Make sure that fuel is drained from the tank.
2. Remove fuel filler tube and hose.

ON BOARD REFUELING VAPOR RECOVERY (ORVR)

[VQ37VHR]

< DTC/CIRCUIT DIAGNOSIS >

3. Check one-way fuel valve for operation as follows.
When a stick is inserted, the valve should open, when removing stick it should close.

Do not drop any material into the tank.

Is the inspection result normal?

YES >> INSPECTION END

NO >> Replace fuel filler tube or replace one-way fuel valve with fuel tank.

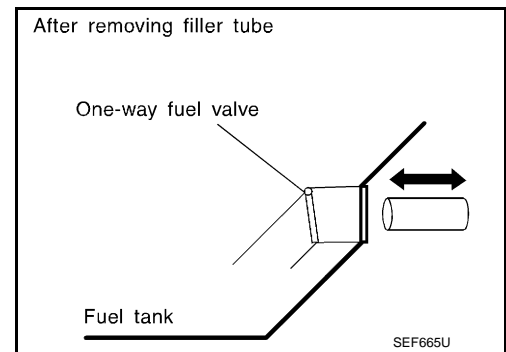

INFOID:000000005152094

Component Inspection

1.INSPECTION START

Do you have CONSULT-III?

Do you have CONSULT-III?

YES >> GO TO 2.

NO >> GO TO 3.

2.CHECK REFUELING EVAP VAPOR CUT VALVE

With CONSULT-III

1. Turn ignition switch OFF.
 2. Remove fuel tank. Refer to [FL-10. "Removal and Installation"](#).
 3. Drain fuel from the tank as follows:
 - Remove fuel feed hose located on the fuel gauge retainer.
 - Connect a spare fuel hose, one side to fuel gauge retainer where the hose was removed and the other side to a fuel container.
 - Drain fuel using "FUEL PUMP RELAY" in "ACTIVE TEST" mode with CONSULT-III.
 4. Check refueling EVAP vapor cut valve for being stuck to close as follows.
Blow air into the refueling EVAP vapor cut valve (from the end of EVAP/ORVR line hose), and check that the air flows freely into the tank.
 5. Check refueling EVAP vapor cut valve for being stuck to open as follows.
 - Connect vacuum pump to hose end.
 - Remove fuel gauge retainer with fuel gauge unit.
- Always replace O-ring with new one.**
- Turn fuel tank upside down.
 - Apply vacuum pressure to hose end [-13.3 kPa (-0.136 kg/cm³, -1.93 psi)] with fuel gauge retainer remaining open and check that the pressure is applicable.

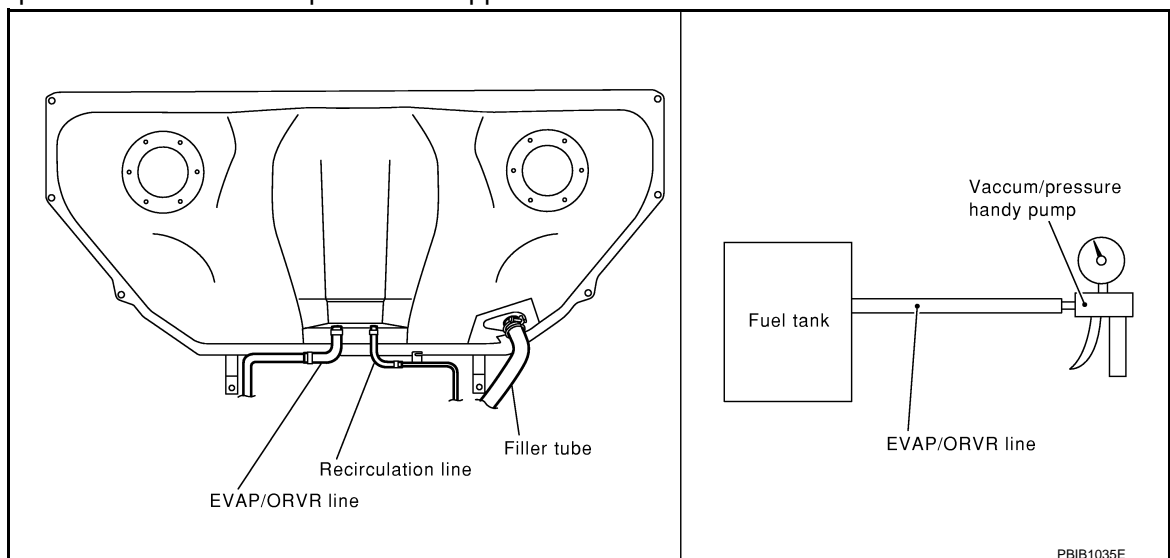

Is the inspection result normal?

YES >> INSPECTION END

ON BOARD REFUELING VAPOR RECOVERY (ORVR)

[VQ37VHR]

< DTC/CIRCUIT DIAGNOSIS >

NO >> Replace refueling EVAP vapor cut valve with fuel tank.

3. CHECK REFUELING EVAP VAPOR CUT VALVE

⊗ Without CONSULT-III

1. Turn ignition switch OFF.
2. Remove fuel tank. Refer to [FL-10. "Removal and Installation"](#).
3. Drain fuel from the tank as follows:
 - Remove fuel gauge retainer.
 - Drain fuel from the tank using a handy pump into a fuel container.
4. Check refueling EVAP vapor cut valve for being stuck to close as follows.
Blow air into the refueling EVAP vapor cut valve (from the end of EVAP/ORVR line hose), and check that the air flows freely into the tank.
5. Check refueling EVAP vapor cut valve for being stuck to open as follows.
 - Connect vacuum pump to hose end.
 - Remove fuel gauge retainer with fuel gauge unit.

Always replace O-ring with new one.

- Turn fuel tank upside down.
- Apply vacuum pressure to hose end [-13.3 kPa (-0.136 kg/cm³, -1.93 psi)] with fuel gauge retainer remaining open and check that the pressure is applicable.

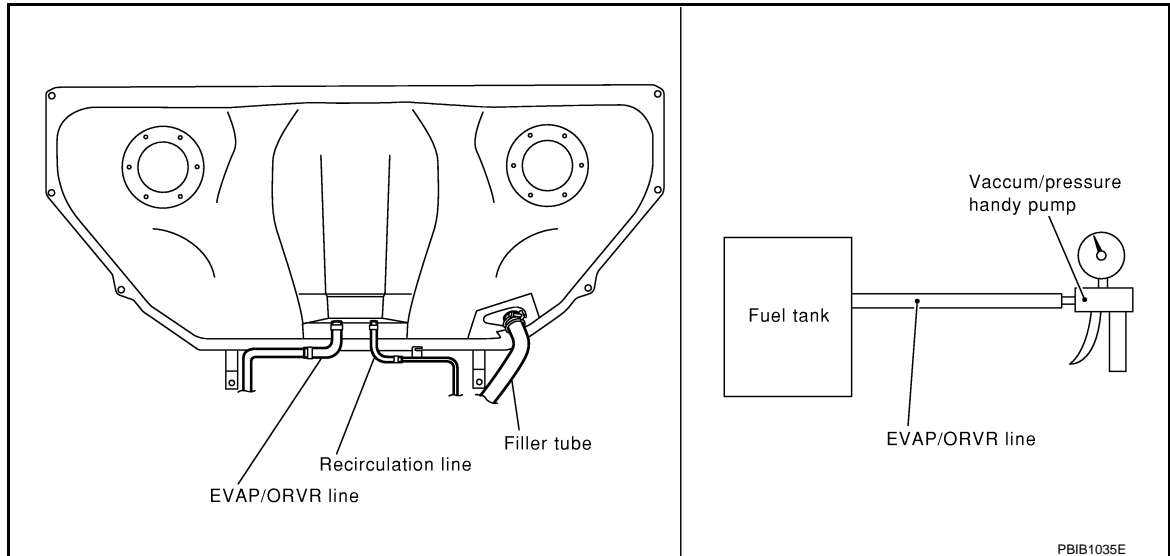

Is the inspection result normal?

YES >> INSPECTION END

NO >> Replace refueling EVAP vapor cut valve with fuel tank.

POSITIVE CRANKCASE VENTILATION

< DTC/CIRCUIT DIAGNOSIS >

[VQ37VHR]

POSITIVE CRANKCASE VENTILATION

Description

INFOID:000000005152095

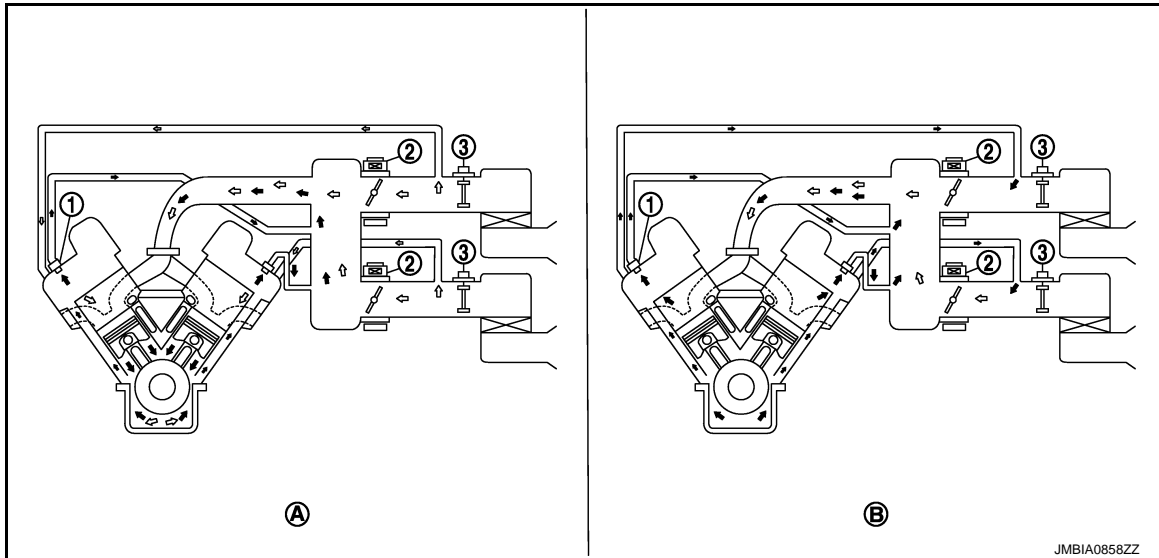

- 1. PCV valve
 - 2. Electric throttle control actuator
 - 3. Mass air flow sensor
- A. Normal condition B. Hi-load condition

⇐ : Fresh air
 ← : Blow-by air

This system returns blow-by gas to the intake manifold.

The positive crankcase ventilation (PCV) valve is provided to conduct crankcase blow-by gas to the intake manifold.

During partial throttle operation of the engine, the intake manifold sucks the blow-by gas through the PCV valve.

Normally, the capacity of the valve is sufficient to handle any blow-by and a small amount of ventilating air.

The ventilating air is then drawn from the air inlet tubes into the crankcase. In this process the air passes through the hose connecting air inlet tubes to rocker cover.

Under full-throttle condition, the manifold vacuum is insufficient to draw the blow-by flow through the valve. The flow goes through the hose connection in the reverse direction.

On vehicles with an excessively high blow-by, the valve does not meet the requirement. This is because some of the flow will go through the hose connection to the air inlet tubes under all conditions.

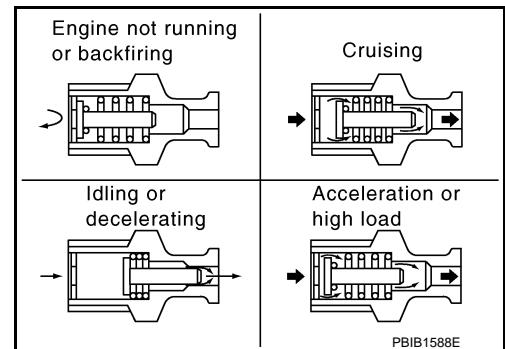

Component Inspection

INFOID:000000005152096

1. CHECK PCV VALVE

POSITIVE CRANKCASE VENTILATION

< DTC/CIRCUIT DIAGNOSIS >

[VQ37VHR]

With engine running at idle, remove PCV valve from rocker cover. A properly working valve makes a hissing noise as air passes through it. A strong vacuum should be felt immediately when a finger is placed over valve inlet.

Is the inspection result normal?

YES >> INSPECTION END
NO >> Replace PCV valve.

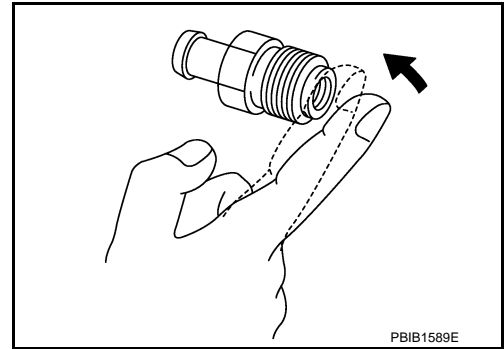

A

EC

C

D

E

F

G

H

I

J

K

L

M

N

O

P

REFRIGERANT PRESSURE SENSOR

< DTC/CIRCUIT DIAGNOSIS >

[VQ37VHR]

REFRIGERANT PRESSURE SENSOR

Description

INFOID:000000005152097

The refrigerant pressure sensor is installed at the condenser of the air conditioner system. The sensor uses an electrostatic volume pressure transducer to convert refrigerant pressure to voltage. The voltage signal is sent to ECM, and ECM controls cooling fan system.

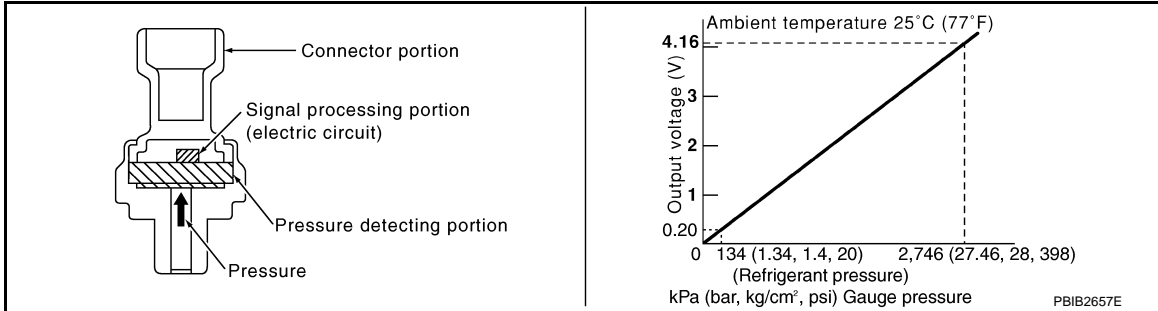

Component Function Check

INFOID:000000005152098

1. CHECK REFRIGERANT PRESSURE SENSOR FUNCTION

1. Start engine and warm it up to normal operating temperature.
2. Turn A/C switch and blower fan switch ON.
3. Check the voltage between ECM harness connector terminals as per the following.

Connector	ECM		Voltage (V)
	+	-	
	Terminal	Terminal	
M107	105 (Refrigerant pressure sensor signal)	112	1.0 - 4.0

Is the inspection result normal?

- YES >> INSPECTION END
 NO >> Go to [EC-516, "Diagnosis Procedure"](#).

Diagnosis Procedure

INFOID:000000005152099

1. CHECK GROUND CONNECTION

1. Turn A/C switch and blower fan switch OFF.
2. Turn ignition switch OFF.
3. Check ground connection M95. Refer to Ground Inspection in [GI-39, "Circuit Inspection"](#).

Is the inspection result normal?

- YES >> GO TO 2.
 NO >> Repair or replace ground connection.

2. CHECK REFRIGERANT PRESSURE SENSOR POWER SUPPLY CIRCUIT

1. Disconnect refrigerant pressure sensor harness connector.
2. Turn ignition switch ON.
3. Check the voltage between refrigerant pressure sensor harness connector and ground.

Refrigerant pressure sensor		Ground	Voltage (V)
Connector	Terminal		
E77	3	Ground	Approx. 5

Is the inspection result normal?

- YES >> GO TO 4.
 NO >> GO TO 3.

REFRIGERANT PRESSURE SENSOR

< DTC/CIRCUIT DIAGNOSIS >

[VQ37VHR]

3. DETECT MALFUNCTIONING PART

Check the following.

- Harness connectors M6, E106
- Harness for open or short between ECM and refrigerant pressure sensor

>> Repair open circuit, short to ground or short to power in harness or connectors.

4. CHECK REFRIGERANT PRESSURE SENSOR GROUND CIRCUIT FOR OPEN AND SHORT

1. Turn ignition switch OFF.
2. Disconnect ECM harness connector.
3. Check the continuity between refrigerant pressure sensor harness connector and ECM harness connector.

Refrigerant pressure sensor		ECM		Continuity
Connector	Terminal	Connector	Terminal	
E77	1	M107	112	Existed

4. Also check harness for short to ground and short to power.

Is the inspection result normal?

- YES >> GO TO 6.
NO >> GO TO 5.

5. DETECT MALFUNCTIONING PART

Check the following.

- Harness connectors M6, E106
- Harness for open or short between ECM and refrigerant pressure sensor

>> Repair open circuit, short to ground or short to power in harness or connectors.

6. CHECK REFRIGERANT PRESSURE SENSOR INPUT SIGNAL CIRCUIT FOR OPEN AND SHORT

1. Check the continuity between refrigerant pressure sensor harness connector and ECM harness connector.

Refrigerant pressure sensor		ECM		Continuity
Connector	Terminal	Connector	Terminal	
E77	2	M107	105	Existed

2. Also check harness for short to ground and short to power.

Is the inspection result normal?

- YES >> GO TO 8.
NO >> GO TO 7.

7. DETECT MALFUNCTIONING PART

Check the following.

- Harness connectors M6, E106
- Harness for open or short between ECM and refrigerant pressure sensor

>> Repair open circuit, short to ground or short to power in harness or connectors.

8. CHECK INTERMITTENT INCIDENT

Refer to [GI-36. "Intermittent Incident"](#).

Is the inspection result normal?

- YES >> Replace refrigerant pressure sensor.
NO >> Repair or replace.

ECU DIAGNOSIS INFORMATION

ECM

Reference Value

INFOID:000000005152104

VALUES ON THE DIAGNOSIS TOOL

NOTE:

- Specification data are reference values.
- Specification data are output/input values which are detected or supplied by the ECM at the connector.
 - * Specification data may not be directly related to their components signals/values/operations.
 - i.e. Adjust ignition timing with a timing light before monitoring IGN TIMING, because the monitor may show the specification data in spite of the ignition timing not being adjusted to the specification data. This IGN TIMING monitors the data calculated by the ECM according to the signals input from the camshaft position sensor and other ignition timing related sensors.

CONSULT-III MONITOR ITEM

Monitor Item	Condition		Values/Status
ENG SPEED	• Run engine and compare CONSULT-III value with the tachometer indication.		Almost the same speed as the tachometer indication
MAS A/F SE-B1	See EC-132, "Description" .		
MAS A/F SE-B2	See EC-132, "Description" .		
B/FUEL SCHDL	See EC-132, "Description" .		
A/F ALPHA-B1	See EC-132, "Description" .		
A/F ALPHA-B2	See EC-132, "Description" .		
COOLAN TEMP/S	• Ignition switch: ON		Indicates engine coolant temperature
A/F SEN1 (B1)	• Engine: After warming up	Maintaining engine speed at 2,000 rpm	Fluctuates around 2.2 V
A/F SEN1 (B2)	• Engine: After warming up	Maintaining engine speed at 2,000 rpm	Fluctuates around 2.2 V
HO2S2 (B1)	<ul style="list-style-type: none"> • Revving engine from idle up to 3,000 rpm quickly after the following conditions are met. <ul style="list-style-type: none"> - Engine: After warming up - After keeping engine speed between 3,500 and 4,000 rpm for 1 minute and at idle for 1 minute under no load 		0 - 0.3 V ↔ Approx. 0.6 - 1.0 V
HO2S2 (B2)	<ul style="list-style-type: none"> • Revving engine from idle up to 3,000 rpm quickly after the following conditions are met. <ul style="list-style-type: none"> - Engine: After warming up - After keeping engine speed between 3,500 and 4,000 rpm for 1 minute and at idle for 1 minute under no load 		0 - 0.3 V ↔ Approx. 0.6 - 1.0 V
HO2S2 MNTR (B1)	<ul style="list-style-type: none"> • Revving engine from idle up to 3,000 rpm quickly after the following conditions are met. <ul style="list-style-type: none"> - Engine: After warming up - After keeping engine speed between 3,500 and 4,000 rpm for 1 minute and at idle for 1 minute under no load 		LEAN ↔ RICH
HO2S2 MNTR (B2)	<ul style="list-style-type: none"> • Revving engine from idle up to 3,000 rpm quickly after the following conditions are met. <ul style="list-style-type: none"> - Engine: After warming up - After keeping engine speed between 3,500 and 4,000 rpm for 1 minute and at idle for 1 minute under no load 		LEAN ↔ RICH
VHCL SPEED SE	• Turn drive wheels and compare CONSULT-III value with the speedometer indication.		Almost the same speed as speedometer indication
BATTERY VOLT	• Ignition switch: ON (Engine stopped)		11 - 14 V
ACCEL SEN 1	• Ignition switch: ON (Engine stopped)	Accelerator pedal: Fully released	0.45 - 1.00 V
		Accelerator pedal: Fully depressed	4.4 - 4.8 V
ACCEL SEN 2*1	• Ignition switch: ON (Engine stopped)	Accelerator pedal: Fully released	0.45 - 1.00 V
		Accelerator pedal: Fully depressed	4.3 - 4.8 V

ECM

< ECU DIAGNOSIS INFORMATION >

[VQ37VHR]

Monitor Item	Condition		Values/Status
TP SEN 1-B1	<ul style="list-style-type: none"> Ignition switch: ON (Engine stopped) Selector lever: D (A/T) or 1st (M/T) 	Accelerator pedal: Fully released	More than 0.36 V
		Accelerator pedal: Fully depressed	Less than 4.75 V
TP SEN 2-B1*1	<ul style="list-style-type: none"> Ignition switch: ON (Engine stopped) Selector lever: D (A/T) or 1st (M/T) 	Accelerator pedal: Fully released	More than 0.36 V
		Accelerator pedal: Fully depressed	Less than 4.75 V
FUEL T/TMP SE	<ul style="list-style-type: none"> Ignition switch: ON 		Indicates fuel tank temperature
INT/A TEMP SE	<ul style="list-style-type: none"> Ignition switch: ON 		Indicates intake air temperature
EVAP SYS PRES	<ul style="list-style-type: none"> Ignition switch: ON 		Approx. 1.8 - 4.8 V
FUEL LEVEL SE	<ul style="list-style-type: none"> Ignition switch: ON 		Depending on fuel level of fuel tank
START SIGNAL	<ul style="list-style-type: none"> Ignition switch: ON → START → ON 		OFF → ON → OFF
CLSD THL POS	<ul style="list-style-type: none"> Ignition switch: ON (Engine stopped) 	Accelerator pedal: Fully released	ON
		Accelerator pedal: Slightly depressed	OFF
AIR COND SIG	<ul style="list-style-type: none"> Engine: After warming up, idle the engine 	Air conditioner switch: OFF	OFF
		Air conditioner switch: ON (Compressor operates.)	ON
P/N POSI SW	<ul style="list-style-type: none"> Ignition switch: ON 	Selector lever: P or N (A/T), Neutral (M/T)	ON
		Selector lever: Except above	OFF
PW/ST SIGNAL	<ul style="list-style-type: none"> Engine: After warming up, idle the engine 	Steering wheel: Not being turned	OFF
		Steering wheel: Being turned	ON
LOAD SIGNAL	<ul style="list-style-type: none"> Ignition switch: ON 	Rear window defogger switch: ON and/or Lighting switch: 2nd position	ON
		Rear window defogger switch and lighting switch: OFF	OFF
IGNITION SW	<ul style="list-style-type: none"> Ignition switch: ON → OFF → ON 		ON → OFF → ON
HEATER FAN SW	<ul style="list-style-type: none"> Engine: After warming up, idle the engine 	Heater fan switch: ON	ON
		Heater fan switch: OFF	OFF
BRAKE SW	<ul style="list-style-type: none"> Ignition switch: ON 	Brake pedal: Fully released	OFF
		Brake pedal: Slightly depressed	ON
INJ PULSE-B1	<ul style="list-style-type: none"> Engine: After warming up Selector lever: P or N (A/T), Neutral (M/T) Air conditioner switch: OFF No load 	Idle	2.0 - 3.0 msec
		2,000 rpm	1.9 - 2.9 msec
INJ PULSE-B2	<ul style="list-style-type: none"> Engine: After warming up Selector lever: P or N (A/T), Neutral (M/T) Air conditioner switch: OFF No load 	Idle	2.0 - 3.0 msec
		2,000 rpm	1.9 - 2.9 msec
IGN TIMING	<ul style="list-style-type: none"> Engine: After warming up Selector lever: P or N (A/T), Neutral (M/T) Air conditioner switch: OFF No load 	Idle	7° BTDC
		2,000 rpm	25° - 45° BTDC
CAL/LD VALUE	<ul style="list-style-type: none"> Engine: After warming up Selector lever: P or N (A/T), Neutral (M/T) Air conditioner switch: OFF No load 	Idle	5% - 35%
		2,500 rpm	5% - 35%

A

EC

C

D

E

F

G

H

I

J

K

L

M

N

O

P

ECM

< ECU DIAGNOSIS INFORMATION >

[VQ37VHR]

Monitor Item	Condition	Values/Status	
MASS AIRFLOW	<ul style="list-style-type: none"> Engine: After warming up Selector lever: P or N (A/T), Neutral (M/T) Air conditioner switch: OFF No load 	Idle 2,500 rpm	2.0 - 6.0 g-m/s 7.0 - 20.0 g-m/s
	PURG VOL C/V	<ul style="list-style-type: none"> Engine: After warming up Selector lever: P or N (A/T), Neutral (M/T) Air conditioner switch: OFF No load 	Idle (Accelerator pedal: Not depressed even slightly, after engine starting.) 2,000 rpm
INT/V TIM (B1)		<ul style="list-style-type: none"> Engine: After warming up Selector lever: P or N (A/T), Neutral (M/T) Air conditioner switch: OFF No load 	Idle 2,000 rpm
	INT/V TIM (B2)		<ul style="list-style-type: none"> Engine: After warming up Selector lever: P or N (A/T), Neutral (M/T) Air conditioner switch: OFF No load
INT/V SOL (B1)		<ul style="list-style-type: none"> Engine: After warming up Selector lever: P or N (A/T), Neutral (M/T) Air conditioner switch: OFF No load 	
	INT/V SOL (B2)		<ul style="list-style-type: none"> Engine: After warming up Selector lever: P or N (A/T), Neutral (M/T) Air conditioner switch: OFF No load
TP SEN 1-B2		<ul style="list-style-type: none"> Ignition switch: ON (Engine stopped) Selector lever: D (A/T) or 1st (M/T) 	
	TP SEN 2-B2*1		<ul style="list-style-type: none"> Ignition switch: ON (Engine stopped) Selector lever: D (A/T) or 1st (M/T)
AIR COND RLY		<ul style="list-style-type: none"> Engine: After warming up, idle the engine 	
	FUEL PUMP RLY		<ul style="list-style-type: none"> For 1 second after turning ignition switch: ON Engine running or cranking
VENT CONT/V		<ul style="list-style-type: none"> Ignition switch: ON 	
THRTL RELAY	<ul style="list-style-type: none"> Ignition switch: ON 	ON	ON
HO2S2 HTR (B1)	<ul style="list-style-type: none"> Engine speed: Below 3,600 rpm after the following conditions are met. <ul style="list-style-type: none"> Engine: After warming up Keeping the engine speed between 3,500 and 4,000 rpm for 1 minute and at idle for 1 minute under no load Engine speed: Above 3,600 rpm 	ON OFF	ON OFF
		HO2S2 HTR (B2)	<ul style="list-style-type: none"> Engine speed: Below 3,600 rpm after the following conditions are met. <ul style="list-style-type: none"> Engine: After warming up Keeping the engine speed between 3,500 and 4,000 rpm for 1 minute and at idle for 1 minute under no load Engine speed: Above 3,600 rpm
VEHICLE SPEED	<ul style="list-style-type: none"> Turn drive wheels and compare CONSULT-III value with the speedometer indication. 		

ECM

< ECU DIAGNOSIS INFORMATION >

[VQ37VHR]

Monitor Item	Condition		Values/Status
IDL A/V LEARN	• Engine: Running	Idle air volume learning has not been performed yet.	YET
		Idle air volume learning has already been performed successfully.	CMPLT
ENG OIL TEMP	• Engine: After warming up		More than 70°C (158°F)
TRVL AFTER MIL	• Ignition switch: ON	Vehicle has traveled after MIL has illuminated.	0 - 65,535 km (0 - 40,723 miles)
A/F S1 HTR (B1)	• Engine: After warming up, idle the engine (More than 140 seconds after starting engine)		4 - 100%
A/F S1 HTR (B2)	• Engine: After warming up, idle the engine (More than 140 seconds after starting engine)		4 - 100%
AC PRESS SEN	• Engine: Idle • Both A/C switch and blower fan switch: ON (Compressor operates)		1.0 - 4.0 V
VHCL SPEED SE	• Turn drive wheels and compare CONSULT-III value with the speedometer indication.		Almost the same speed as the speedometer indication
SET VHCL SPD	• Engine: Running	ASCD: Operating	The preset vehicle speed is displayed
MAIN SW	• Ignition switch: ON	MAIN switch: Pressed	ON
		MAIN switch: Released	OFF
CANCEL SW	• Ignition switch: ON	CANCEL switch: Pressed	ON
		CANCEL switch: Released	OFF
RESUME/ACC SW	• Ignition switch: ON	RESUME/ACCELERATE switch: Pressed	ON
		RESUME/ACCELERATE switch: Released	OFF
SET SW	• Ignition switch: ON	SET/COAST switch: Pressed	ON
		SET/COAST switch: Released	OFF
BRAKE SW1 (ICC/ASCD brake switch)	• Ignition switch: ON	Brake pedal: Fully released	ON
		Brake pedal: Slightly depressed	OFF
BRAKE SW2 (Stop lamp switch)	• Ignition switch: ON	Brake pedal: Fully released	OFF
		Brake pedal: Slightly depressed	ON
VHCL SPD CUT	• Ignition switch: ON		NON
LO SPEED CUT	• Ignition switch: ON		NON
AT OD MONITOR	• Ignition switch: ON		OFF
AT OD CANCEL	• Ignition switch: ON		OFF
SET LAMP	• Set switch: ON • Vehicle Speed: Between 40 km/h (25 MPH) and 144 km/h (89 MPH)	SET/COAST switch: Pressed	ON
		SET/COAST switch: Released	OFF
CRUISE LAMP	• Ignition switch: ON	MAIN switch: Pressed at the 1st time → at the 2nd time	ON → OFF
BAT CUR SEN	• Engine speed: Idle • Battery: Fully charged*2 • Selector lever: P or N (A/T), Neutral (M/T) • Air conditioner switch: OFF • No load		Approx. 2,600 - 3,500 mV
ALT DUTY	• Engine: Idle		0 - 80%
ATOM PRES SEN	• This item is displayed but is not applicable to this model.		
BRAKE BST PRES SE	• This item is displayed but is not applicable to this model.		

A
EC
C
D
E
F
G
H
I
J
K
L
M
N
O
P

< ECU DIAGNOSIS INFORMATION >

Monitor Item	Condition	Values/Status
VVEL POSITION SEN-B1	• Engine: After warming up • Selector lever: P or N (A/T), Neutral (M/T) • Air conditioner switch: OFF • No load	Idle Approx. 0.25 - 1.40 V
		When revving engine up to 2,000 rpm quickly Approx. 0.25 - 4.75 V
VVEL POSITION SEN-B2	• Engine: After warming up • Selector lever: P or N (A/T), Neutral (M/T) • Air conditioner switch: OFF • No load	Idle Approx. 0.25 - 1.40 V
		When revving engine up to 2,000 rpm quickly Approx. 0.25 - 4.75 V
VVEL TIM-B1	• Engine: After warming up • Selector lever: P or N (A/T), Neutral (M/T) • Air conditioner switch: OFF • No load	Idle Approx. 0 - 20 deg
		When revving engine up to 2,000 rpm quickly Approx. 0 - 90 deg
VVEL TIM-B2	• Engine: After warming up • Selector lever: P or N (A/T), Neutral (M/T) • Air conditioner switch: OFF • No load	Idle Approx. 0 - 20 deg
		When revving engine up to 2,000 rpm quickly Approx. 0 - 90 deg
VVEL LEARN	• Ignition switch: OFF → ON (After warming up)	VVEL learning has not been performed yet. YET
		VVEL learning has already been performed successfully. DONE
VVEL SEN LEARN-B1	• VVEL learning has already been performed successfully	Approx. 0.30 - 0.80 V
VVEL SEN LEARN-B2	• VVEL learning has already been performed successfully	Approx. 0.30 - 0.80 V
A/F ADJ-B1	• Engine: Running	-0.330 - 0.330
A/F ADJ-B2	• Engine: Running	-0.330 - 0.330
FAN DUTY	• Engine: Running	0 - 100%
ALT DUTY SIG	• Power generation voltage variable control: Operating	ON
	• Power generation voltage variable control: Not operating	OFF

*1: Accelerator pedal position sensor 2 signal and throttle position sensor 2 signal are converted by ECM internally. Thus, they differ from ECM terminals voltage signal.

*2: Before measuring the terminal voltage, confirm that the battery is fully charged. Refer to [PG-3, "How to Handle Battery"](#).

TERMINAL LAYOUT

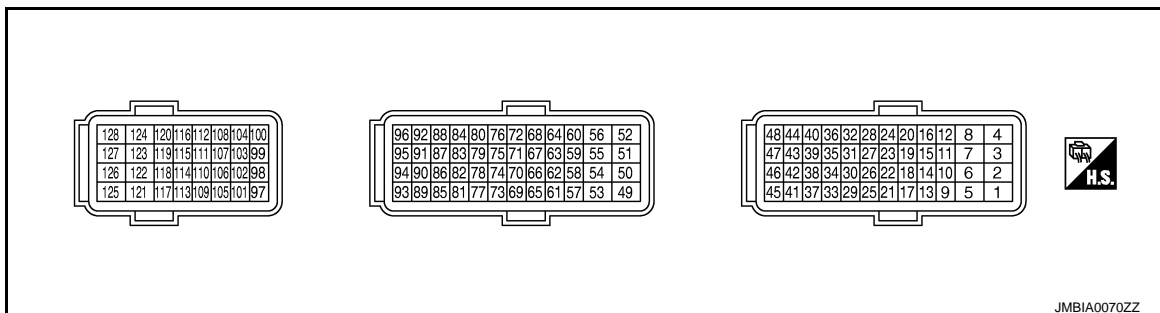

PHYSICAL VALUES

NOTE:

- ECM is located behind the instrument assist lower panel. For this inspection, remove passenger side instrument lower panel.
- Specification data are reference values and are measured between each terminal and ground.
- Pulse signal is measured by CONSULT-III.

ECM

< ECU DIAGNOSIS INFORMATION >

[VQ37VHR]

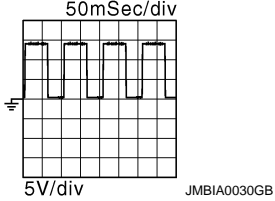
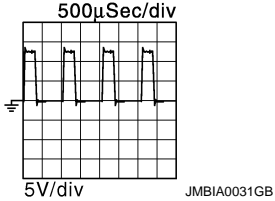
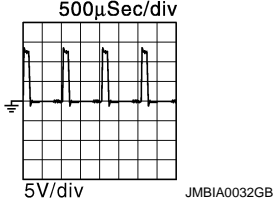
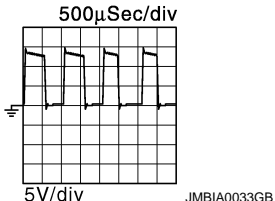
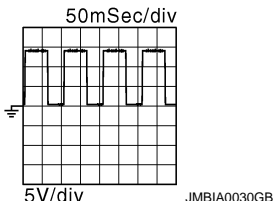
Terminal No. (Wire color)		Description		Condition	Value (Approx.)
+	—	Signal name	Input/ Output		
1 (W)	128 (B)	A/F sensor 1 heater (bank 1)	Output	[Engine is running] • Warm-up condition • Idle speed (More than 140 seconds after starting engine)	2.9 - 8.8 V★ 
2 (G)	128 (B)	Throttle control motor (Open) (bank 1)	Output	[Ignition switch: ON] • Engine stopped • Selector lever: D (A/T) or 1st (M/T) • Accelerator pedal: Fully depressed	0 - 14 V★ 
				[Ignition switch: ON] • Engine stopped • Selector lever: D (A/T) or 1st (M/T) • Accelerator pedal: Fully released	0 - 14 V★ 
3 (R)	128 (B)	Throttle control motor power supply (bank 1)	Input	[Ignition switch: ON]	BATTERY VOLTAGE (11 - 14 V)
4 (BR)	128 (B)	Throttle control motor (Close) (bank 1)	Output	[Ignition switch: ON] • Engine stopped • Selector lever: D (A/T) or 1st (M/T) • Accelerator pedal: In the middle of re- leasing operation	0 - 14 V★ 
5 (W)	128 (B)	A/F sensor 1 heater (bank 2)	Output	[Engine is running] • Warm-up condition • Idle speed (More than 140 seconds after starting engine)	2.9 - 8.8 V★ 
8 (B)	—	ECM ground	—	—	—

A
EC
C
D
E
F
G
H
I
J
K
L
M
N
O
P

ECM

< ECU DIAGNOSIS INFORMATION >

[VQ37VHR]

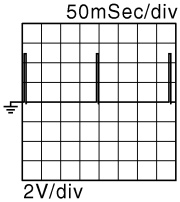
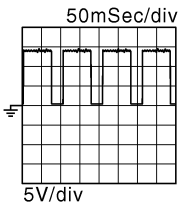
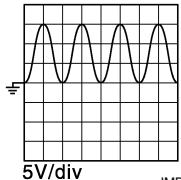
Terminal No. (Wire color)		Description		Condition	Value (Approx.)
+	--	Signal name	Input/ Output		
11 (GR)	128 (B)	Ignition signal No. 4	Output	[Engine is running] <ul style="list-style-type: none"> • Warm-up condition • Idle speed NOTE: The pulse cycle changes depending on rpm at idle	0 - 0.2 V★ 
12 (L)		Ignition signal No. 3			
15 (V)		Ignition signal No. 5			
16 (G)		Ignition signal No. 2			
19 (SB)		Ignition signal No. 6			
20 (Y)		Ignition signal No. 1			
17 (P)	128 (B)	Heated oxygen sensor 2 heater (bank 1)	Output	[Engine is running] <ul style="list-style-type: none"> • Engine speed: Below 3,600 rpm after the following conditions are met <ul style="list-style-type: none"> - Engine: after warming up - Keeping the engine speed between 3,500 and 4,000 rpm for 1 minute and at idle for 1 minute under no load 	10 V★ 
			Output	[Ignition switch: ON] <ul style="list-style-type: none"> • Engine stopped [Engine is running] <ul style="list-style-type: none"> • Engine speed: Above 3,600 rpm 	BATTERY VOLTAGE (11 - 14 V)
18 (W)	128 (B)	Intake valve timing control solenoid valve (bank 1)	Output	[Engine is running] <ul style="list-style-type: none"> • Warm-up condition • Idle speed 	BATTERY VOLTAGE (11 - 14 V)
			Output	[Engine is running] <ul style="list-style-type: none"> • Warm-up condition • Engine speed: 2,000rpm 	7 - 12 V★ 

ECM

< ECU DIAGNOSIS INFORMATION >

[VQ37VHR]

Terminal No. (Wire color)		Description		Condition	Value (Approx.)
+	--	Signal name	Input/ Output		
21 (GR)	128 (B)	EVAP canister purge volume control solenoid valve	Output	[Engine is running] • Idle speed • Accelerator pedal: Not depressed even slightly, after engine starting	BATTERY VOLTAGE (11 - 14 V)★
				[Engine is running] • Engine speed: About 2,000 rpm (More than 100 seconds after starting engine)	BATTERY VOLTAGE (11 - 14 V)★
22 (R)	128 (B)	Fuel pump relay	Output	[Ignition switch: ON] • For 1 second after turning ignition switch ON	0 - 1.5 V
				[Engine is running] • More than 1 second after turning ignition switch ON	BATTERY VOLTAGE (11 - 14 V)
24 (P)	128 (B)	ECM relay (Self shut-off)	Output	[Engine is running] [Ignition switch: OFF] • A few seconds after turning ignition switch OFF	0 - 1.5 V
				[Ignition switch: OFF] • More than a few seconds after turning ignition switch OFF	BATTERY VOLTAGE (11 - 14 V)
25 (O)	128 (B)	Throttle control motor relay	Output	[Ignition switch: ON → OFF]	0 - 1.0 V ↓ BATTERY VOLTAGE (11 - 14 V) ↓ 0 V
				[Ignition switch: ON]	0 - 1.0 V
28 (BR)	128 (B)	VVEL actuator motor relay abort signal [VVEL control module]	Output	[Engine is running] • Warm-up condition • Idle speed	0 V
29 (G)	128 (B)	Intake valve timing control solenoid valve (bank 2)	Output	[Engine is running] • Warm-up condition • Idle speed	BATTERY VOLTAGE (11 - 14 V)
				[Engine is running] • Warm-up condition • Engine speed: 2,000rpm	7 - 12 V★

A

EC

C

D

E

F

G

H

I

J

K

L

M

N

O

P

ECM

< ECU DIAGNOSIS INFORMATION >

[VQ37VHR]

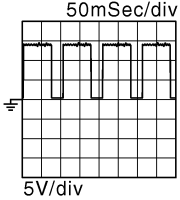
Terminal No. (Wire color)		Description		Condition	Value (Approx.)
+	—	Signal name	Input/ Output		
30 (Y)	40 (R)	Throttle position sensor 1 (bank 1)	Input	[Ignition switch: ON] • Engine stopped • Selector lever: D (A/T) or 1st (M/T) • Accelerator pedal: Fully released	More than 0.36 V
				[Ignition switch: ON] • Engine stopped • Selector lever: D (A/T) or 1st (M/T) • Accelerator pedal: Fully depressed	Less than 4.75 V
31 (R)	48 (B)	Throttle position sensor 1 (bank 2)	Input	[Ignition switch: ON] • Engine stopped • Selector lever: D (A/T) or 1st (M/T) • Accelerator pedal: Fully released	More than 0.36 V
				[Ignition switch: ON] • Engine stopped • Selector lever: D (A/T) or 1st (M/T) • Accelerator pedal: Fully depressed	Less than 4.75 V
33 (SB)	128 (B)	Heated oxygen sensor 2 heater (bank 2)	Output	[Engine is running] • Engine speed: Below 3,600 rpm after the following conditions are met - Engine: after warming up - Keeping the engine speed between 3,500 and 4,000 rpm for 1 minute and at idle for 1 minute under no load	10 V★  5V/div JMBIA0037GB
				[Ignition switch: ON] • Engine stopped [Engine is running] • Engine speed: Above 3,600 rpm	BATTERY VOLTAGE (11 - 14 V)
34 (B)	40 (R)	Throttle position sensor 2 (bank 1)	Input	[Ignition switch: ON] • Engine stopped • Selector lever: D (A/T) or 1st (M/T) • Accelerator pedal: Fully released	Less than 4.75 V
				[Ignition switch: ON] • Engine stopped • Selector lever: D (A/T) or 1st (M/T) • Accelerator pedal: Fully depressed	More than 0.36 V
35 (W)	48 (B)	Throttle position sensor 2 (bank 2)	Input	[Ignition switch: ON] • Engine stopped • Selector lever: D (A/T) or 1st (M/T) • Accelerator pedal: Fully released	Less than 4.75 V
				[Ignition switch: ON] • Engine stopped • Selector lever: D (A/T) or 1st (M/T) • Accelerator pedal: Fully depressed	More than 0.36 V
36 (O)	—	Sensor ground [Brake booster pressure sensor]	—	—	—

ECM

< ECU DIAGNOSIS INFORMATION >

[VQ37VHR]

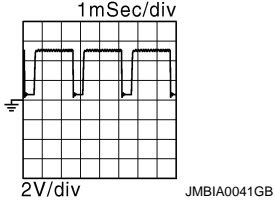
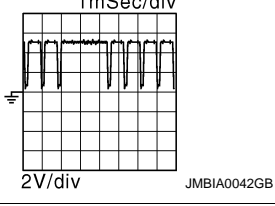
Terminal No. (Wire color)		Description		Condition	Value (Approx.)
+	--	Signal name	Input/ Output		
37 (W)	47 (Y)	Crankshaft position sensor (POS)	Input	[Engine is running] • Warm-up condition • Idle speed NOTE: The pulse cycle changes depending on rpm at idle	4.0 - 5.0 V★ 
				[Engine is running] • Engine speed: 2,000 rpm	4.0 - 5.0 V★ 
38 (O)	96 (P)	Manifold absolute pressure (MAP) sensor	Input	[Engine is running] • Warm-up condition • Idle speed	1.2 V
				[Engine is running] • Warm-up condition • Engine speed: 2,000 rpm	1.5 V
39 (P)	36 (O)	Brake booster pressure sensor	Input	[Engine is running] • Warm-up condition • Idle speed • Brake pedal: Fully released	1.2 V
				[Engine is running] • Warm-up condition • Idle speed • Brake pedal: Fully depressed	3.0 V
40 (R)	—	Sensor ground [Throttle position sensor (bank 1)]	—	—	—
43 (G)	48 (B)	Sensor power supply [Throttle position sensor (bank 2)]	—	[Ignition switch: ON]	5 V
44 (L)	40 (R)	Sensor power supply [Throttle position sensor (bank 1)]	—	[Ignition switch: ON]	5 V
45 (LG)	36 (O)	Sensor power supply [Brake booster pressure sensor]	—	[Ignition switch: ON]	5 V
46 (R)	47 (Y)	Sensor power supply [Crankshaft position sensor (POS)]	—	[Ignition switch: ON]	5 V
47 (Y)	—	Sensor ground [Crankshaft position sensor (POS)]	—	—	—
48 (B)	—	Sensor ground [Throttle position sensor (bank 2)]	—	—	—

A

EC

C

D

E

F

G

H

I

J

K

L

M

N

O

P

ECM

< ECU DIAGNOSIS INFORMATION >

[VQ37VHR]

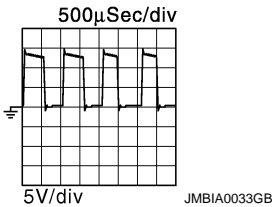
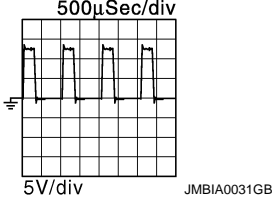
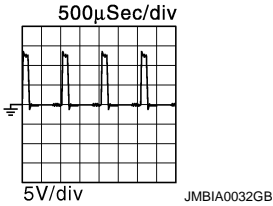
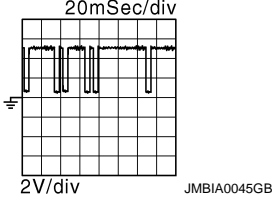
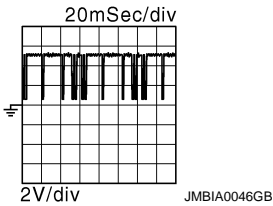
Terminal No. (Wire color)		Description		Condition	Value (Approx.)
+	--	Signal name	Input/ Output		
49 (GR)	128 (B)	Throttle control motor (Close) (bank 2)	Output	[Ignition switch: ON] • Engine stopped • Selector lever: D (A/T) or 1st (M/T) • Accelerator pedal: In the middle of re- leasing operation	0 - 14 V★ 
50 (V)	128 (B)	Throttle control motor (Open) (bank 2)	Output	[Ignition switch: ON] • Engine stopped • Selector lever: D (A/T) or 1st (M/T) • Accelerator pedal: Fully depressed	0 - 14 V★ 
				[Ignition switch: ON] • Engine stopped • Selector lever: D (A/T) or 1st (M/T) • Accelerator pedal: Fully released	0 - 14 V★ 
52 (R)	128 (B)	Throttle control motor power supply (bank 2)	Input	[Ignition switch: ON]	BATTERY VOLTAGE (11 - 14 V)
53 (W)	128 (B)	Ignition switch	Input	[Ignition switch: OFF]	0 V
				[Ignition switch: ON]	BATTERY VOLTAGE (11 - 14 V)
54 (Y)	—	CAN communication line [VVEL control module]	Input/ output	—	—
55 (LG)	—	CAN communication line [VVEL control module]	Input/ output	—	—
57 (L)	128 (B)	A/F sensor 1 (bank 1)	Input	[Ignition switch: ON]	2.2 V
59 (O)	128 (B)	Camshaft position sen- sor (PHASE) (bank 1)	Input	[Engine is running] • Warm-up condition • Idle speed NOTE: The pulse cycle changes depending on rpm at idle	3.0 - 5.0 V★ 
				[Engine is running] • Engine speed: 2,000 rpm	3.0 - 5.0 V★ 

ECM

< ECU DIAGNOSIS INFORMATION >

[VQ37VHR]

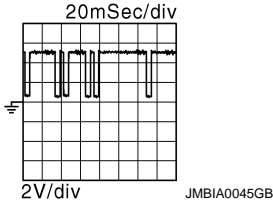
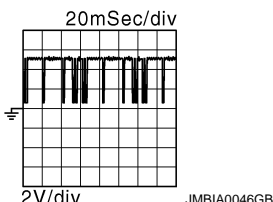
Terminal No. (Wire color)		Description		Condition	Value (Approx.)
+	--	Signal name	Input/ Output		
60 (G)	96 (P)	Sensor power supply [Camshaft position sensor (PHASE) (bank 1), Manifold absolute pressure (MAP) sensor, Power steering pressure sensor]	—	[Ignition switch: ON]	5 V
61 (R)	128 (B)	A/F sensor 1 (bank 1)	Input	[Engine is running] • Warm-up condition • Engine speed: 2,000 rpm	1.8 V Output voltage varies with air fuel ratio.
63 (L)	92 (G)	Camshaft position sensor (PHASE) (bank 2)	Input	[Engine is running] • Warm-up condition • Idle speed NOTE: The pulse cycle changes depending on rpm at idle	3.0 - 5.0 V★ 
				[Engine is running] • Engine speed: 2,000 rpm	3.0 - 5.0 V★ 
64 (SB)	92 (G)	Sensor power supply [Camshaft position sensor (PHASE) (bank 2), Battery current sensor]	—	[Ignition switch: ON]	5 V
65 (LG)	128 (B)	A/F sensor 1 (bank 2)	Input	[Ignition switch: ON]	2.2 V
66 (V)	128 (B)	A/F sensor 1 (bank 2)	Input	[Engine is running] • Warm-up condition • Engine speed: 2,000 rpm	1.8 V Output voltage varies with air fuel ratio.
67 (P)	68 (LG)	Intake air temperature sensor	Input	[Engine is running]	0 - 4.8 V Output voltage varies with intake air temperature.
68 (LG)	—	Sensor ground [Mass air flow sensor (bank 1), Intake air temperature sensor]	—	—	—
69 (W)	128 (B)	Knock sensor (bank 2)	Input	[Engine is running] • Idle speed	2.5 V*1
71 (Y)	84 (B)	Engine coolant temperature sensor	Input	[Engine is running]	0 - 4.8 V Output voltage varies with engine coolant temperature.
72 (—)	—	Sensor ground (Knock sensor)	—	—	—
73 (W)	128 (B)	Knock sensor (bank 1)	Input	[Engine is running] • Idle speed	2.5 V*1

A

EC

C

D

E

F

G

H

I

J

K

L

M

N

O

P

ECM

< ECU DIAGNOSIS INFORMATION >

[VQ37VHR]

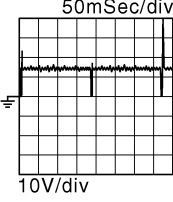
Terminal No. (Wire color)		Description		Condition	Value (Approx.)
+	--	Signal name	Input/ Output		
76 (W)	128 (B)	Heated oxygen sensor 2 (bank 1)	Input	[Engine is running] • Revving engine from idle to 3,000 rpm quickly after the following conditions are met - Engine: after warming up - Keeping the engine speed between 3,500 and 4,000 rpm for 1 minute and at idle for 1 minute under no load	0 - 1.0 V
77 (SB)	68 (LG)	Mass air flow sensor (bank 1)	Input	[Engine is running] • Warm-up condition • Idle speed	0.7 - 1.2 V
				[Engine is running] • Warm-up condition • Engine speed: 2,500 rpm	1.3 - 1.7 V
78 (G)	84 (B)	Engine oil temperature sensor	Input	[Engine is running]	0 - 4.8 V Output voltage varies with engine oil temperature.
79 (BR)	94 (Y)	Mass air flow sensor (bank 2)	Input	[Engine is running] • Warm-up condition • Idle speed	0.7 - 1.2 V
				[Engine is running] • Warm-up condition • Engine speed: 2,500 rpm	1.3 - 1.7 V
80 (O)	128 (B)	Heated oxygen sensor 2 (bank 2)	Input	[Engine is running] • Revving engine from idle to 3,000 rpm quickly after the following conditions are met - Engine: after warming up - Keeping the engine speed between 3,500 and 4,000 rpm for 1 minute and at idle for 1 minute under no load	0 - 1.0 V
81 (R)	128 (B)	Fuel injector No. 3	Output	[Engine is running] • Warm-up condition • Idle speed NOTE: The pulse cycle changes depending on rpm at idle	BATTERY VOLTAGE (11 - 14 V)★ 
82 (V)		Fuel injector No. 6			
85 (BR)		Fuel injector No. 2			
86 (W)		Fuel injector No. 5			
89 (GR)		Fuel injector No. 1			
90 (O)		Fuel injector No. 4			
84 (B)	--	Sensor ground (Heated oxygen sensor 2, Engine coolant temperature sensor, Engine oil temperature sensor)	--	--	--

ECM

< ECU DIAGNOSIS INFORMATION >

[VQ37VHR]

Terminal No. (Wire color)		Description		Condition	Value (Approx.)
+	--	Signal name	Input/ Output		
87 (Y)	96 (P)	Power steering pressure sensor	Output	[Engine is running] • Steering wheel: Being turned	0.5 - 4.5 V
				[Engine is running] • Steering wheel: Not being turned	0.4 - 0.8 V
91 (SB)	95 (G)	Battery current sensor	Input	[Engine is running] • Battery: Fully charged*2 • Idle speed	2.6 - 3.5 V
92 (G)	—	Sensor ground [Camshaft position sensor (PHASE) (bank 2)]	—	—	—
93 (P)	128 (B)	Power supply for ECM (Back-up)	Input	[Ignition switch: OFF]	BATTERY VOLTAGE (11 - 14 V)
94 (Y)	—	Sensor ground [Mass air flow sensor (bank 2)]	—	—	—
95 (G)	—	Sensor ground (Battery current sensor)	—	—	—
96 (P)	—	Sensor ground [Camshaft position sensor (PHASE) (bank 1), Manifold absolute pressure (MAP) sensor, Power steering pressure sensor]	—	—	—
97 (R)	100 (W)	Accelerator pedal position sensor 1	Input	[Ignition switch: ON] • Engine stopped • Accelerator pedal: Fully released	0.45 - 1.00 V
				[Ignition switch: ON] • Engine stopped • Accelerator pedal: Fully depressed	4.2 - 4.8 V
98 (P)	104 (GR)	Accelerator pedal position sensor 2	Input	[Ignition switch: ON] • Engine stopped • Accelerator pedal: Fully released	0.22 - 0.50 V
				[Ignition switch: ON] • Engine stopped • Accelerator pedal: Fully depressed	2.1 - 2.5 V
99 (L)	100 (W)	Sensor power supply (Accelerator pedal position sensor 1)	—	[Ignition switch: ON]	5 V
100 (W)	—	Sensor ground (Accelerator pedal position sensor 1)	—	—	—

A
EC
C
D
E
F
G
H
I
J
K
L
M
N
O
P

ECM

< ECU DIAGNOSIS INFORMATION >

[VQ37VHR]

Terminal No. (Wire color)		Description	Input/ Output	Condition	Value (Approx.)
+	--				
101 (SB)	108 (Y)	ICC steering switch (models with ICC system)	Input	[Ignition switch: ON] • ICC steering switch: OFF	4.3 V
				[Ignition switch: ON] • MAIN switch: Pressed	0 V
				[Ignition switch: ON] • CANCEL switch: Pressed	1.3 V
				[Ignition switch: ON] • RESUME/ACCELERATE switch: Pressed	3.7 V
				[Ignition switch: ON] • SET/COAST switch: Pressed	3 V
				[Ignition switch: ON] • DISTANCE switch: Pressed	2.2 V
101 (SB)	108 (Y)	ASCD steering switch (models with ASCD system)	Input	[Ignition switch: ON] • ASCD steering switch: OFF	4 V
				[Ignition switch: ON] • MAIN switch: Pressed	0 V
				[Ignition switch: ON] • CANCEL switch: Pressed	1 V
				[Ignition switch: ON] • RESUME/ACCELERATE switch: Pressed	3 V
				[Ignition switch: ON] • SET/COAST switch: Pressed	2 V
102 (G)	112 (R)	EVAP control system pressure sensor	Input	[Ignition switch: ON]	1.8 - 4.8 V
103 (G)	104 (GR)	Sensor power supply (Accelerator pedal position sensor 2)	—	[Ignition switch: ON]	5 V
104 (GR)	—	Sensor ground (Accelerator pedal position sensor 2)	—	—	—
105 (L)	112 (R)	Refrigerant pressure sensor	Input	[Engine is running] • Warm-up condition • Both A/C switch and blower fan motor switch: ON (Compressor operates)	1.0 - 4.0 V
106 (W)	128 (B)	Fuel tank temperature sensor	Input	[Engine is running]	0 - 4.8 V Output voltage varies with fuel tank temperature.
107 (BR)	112 (R)	Sensor power supply (EVAP control system pressure sensor, Refrigerant pressure sensor)	—	[Ignition switch: ON]	5 V
108 (Y)	—	Sensor ground (ASCD/ICC steering switch)	—	—	—
109 (G)	128 (B)	PNP switch	Input	[Ignition switch: ON] • Selector lever: P or N (A/T), Neutral (M/ T)	BATTERY VOLTAGE (11 - 14 V)
				[Ignition switch: ON] • Selector lever: Except above	0 V

ECM

< ECU DIAGNOSIS INFORMATION >

[VQ37VHR]

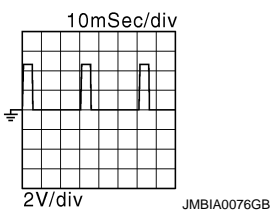
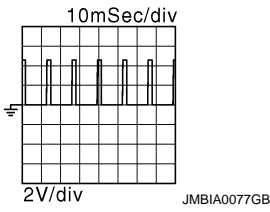
Terminal No. (Wire color)		Description		Condition	Value (Approx.)
+	--	Signal name	Input/ Output		
110 (R)	128 (B)	Engine speed output signal	Output	[Engine is running] • Warm-up condition • Idle speed NOTE: The pulse cycle changes depending on rpm at idle	1 V★ 
				[Engine is running] • Engine speed is 2,000 rpm	1 V★ 
112 (R)	—	Sensor ground (EVAP control system pressure sensor, Refrigerant pressure sensor)	—	—	—
113 (P)	—	CAN communication line	Input/ Output	—	—
114 (L)	—	CAN communication line	Input/ Output	—	—
117 (V)	128 (B)	Data link connector	Input/ Output	—	—
121 (LG)	128 (B)	EVAP canister vent control valve	Output	[Ignition switch: ON]	BATTERY VOLTAGE (11 - 14 V)
122 (P)	128 (B)	Stop lamp switch	Input	[Ignition switch: OFF] • Brake pedal: Fully released	0 V
				[Ignition switch: OFF] • Brake pedal: Slightly depressed	BATTERY VOLTAGE (11 - 14 V)
123 (B) 124 (B)	—	ECM ground	—	—	—
125 (R)	128 (B)	Power supply for ECM	Input	[Ignition switch: ON]	BATTERY VOLTAGE (11 - 14 V)
126 (BR)	128 (B)	ICC brake switch (models with ICC system) ASCDC brake switch (models with ASCDC system)	Input	[Ignition switch: ON] • Brake pedal: Slightly depressed	0 V
				[Ignition switch: ON] • Brake pedal: Fully released	BATTERY VOLTAGE (11 - 14 V)
127 (B) 128 (B)	—	ECM ground	—	—	—

★: Average voltage for pulse signal (Actual pulse signal can be confirmed by oscilloscope.)

*1: This may vary depending on internal resistance of the tester.

**2: Before measuring the terminal voltage, confirm that the battery is fully charged. Refer to [PG-3, "How to Handle Battery"](#).

A
EC
C
D
E
F
G
H
I
J
K
L
M
N
O
P

Wiring Diagram - ENGINE CONTROL SYSTEM -

INFOID:000000005152105

ENGINE CONTROL SYSTEM

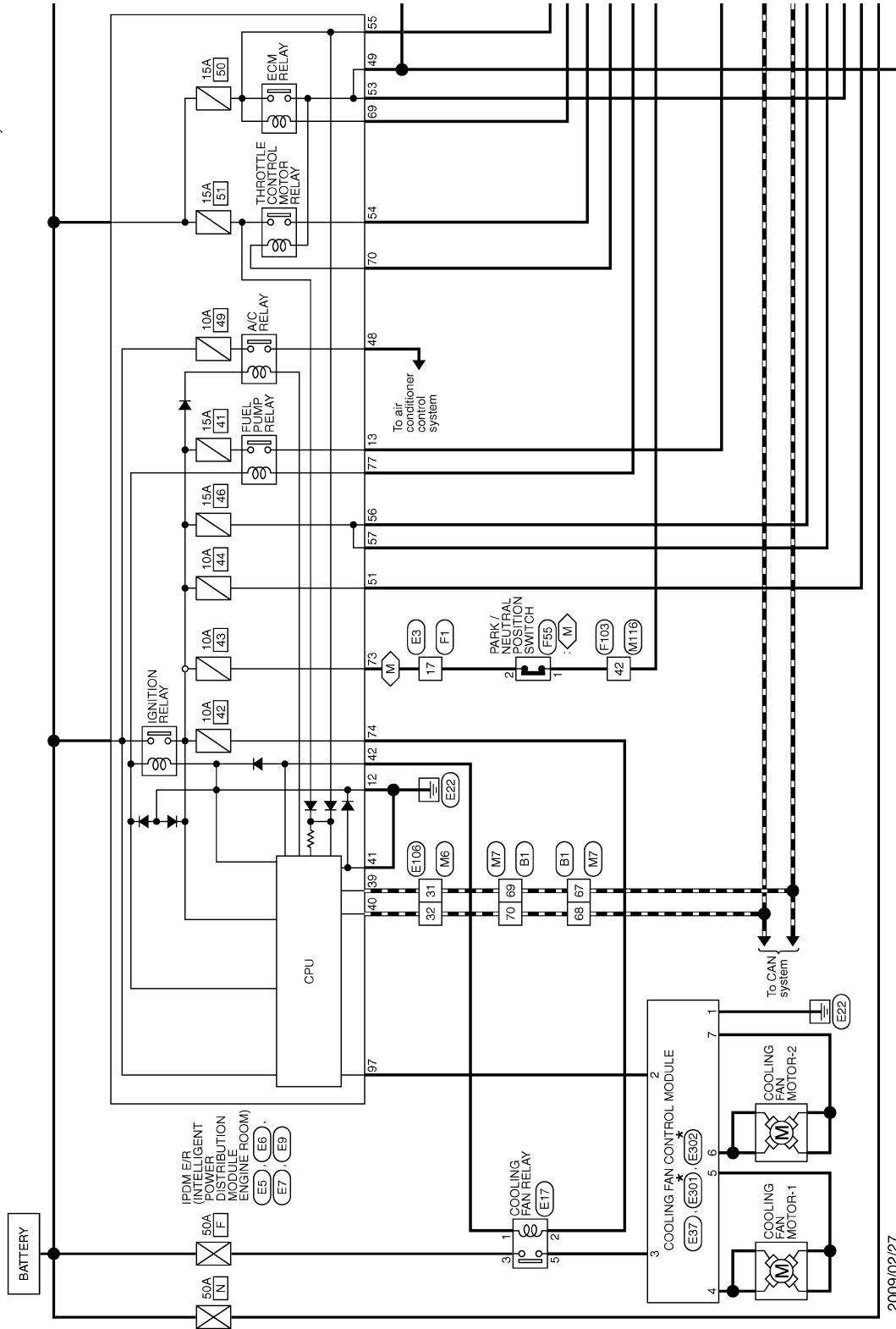

M: With M/T

*: This connector is not shown in "Harness Layout".

2009/02/27

JCBWA1339GB

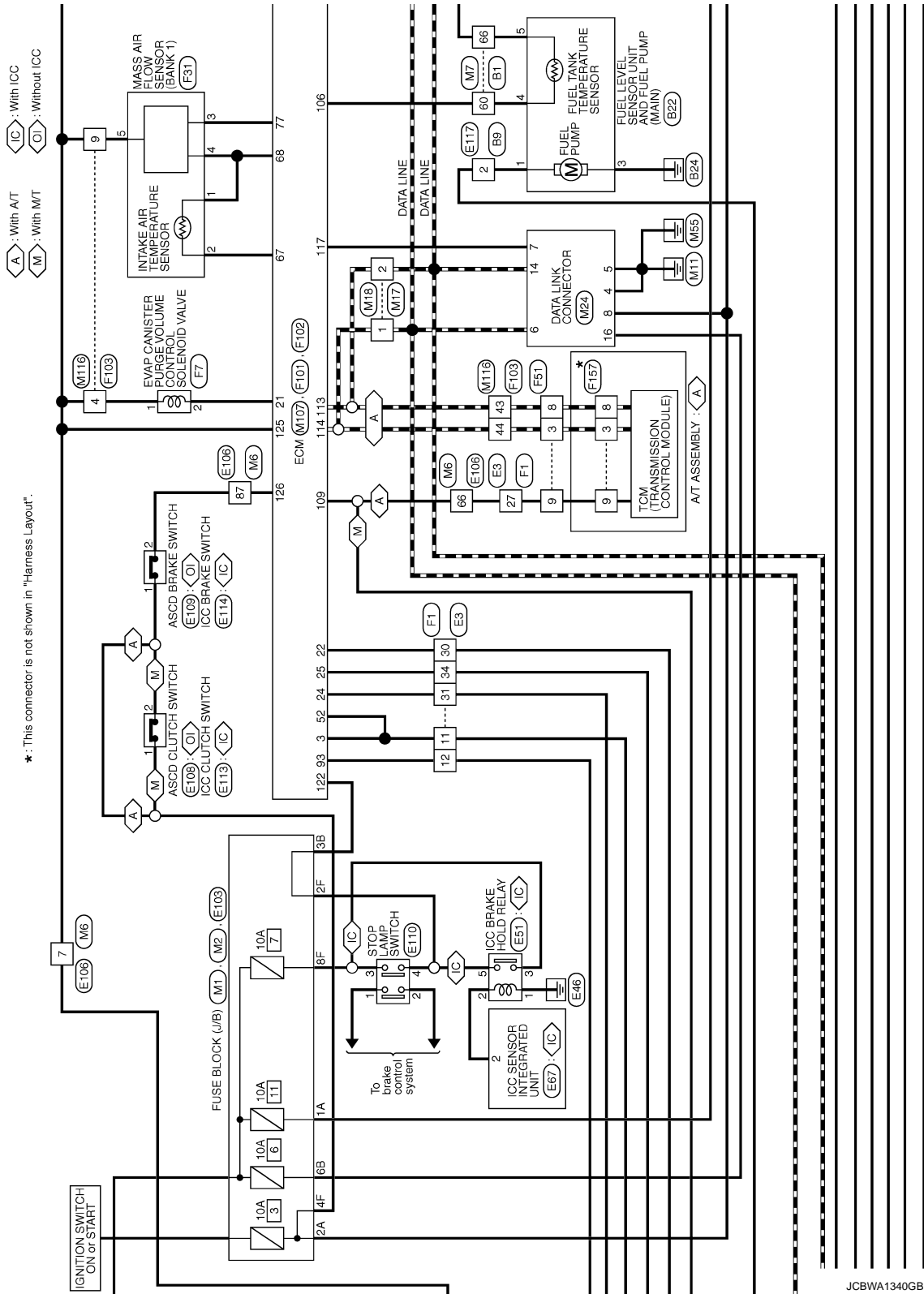

*: This connector is not shown in "Harness Layout".

JCBWA1340GB

A
EC
C
D
E
F
G
H
I
J
K
L
M
N
O
P

*: This connector is not shown in "Harness Layout".

IC : With ICC
OI : Without ICC

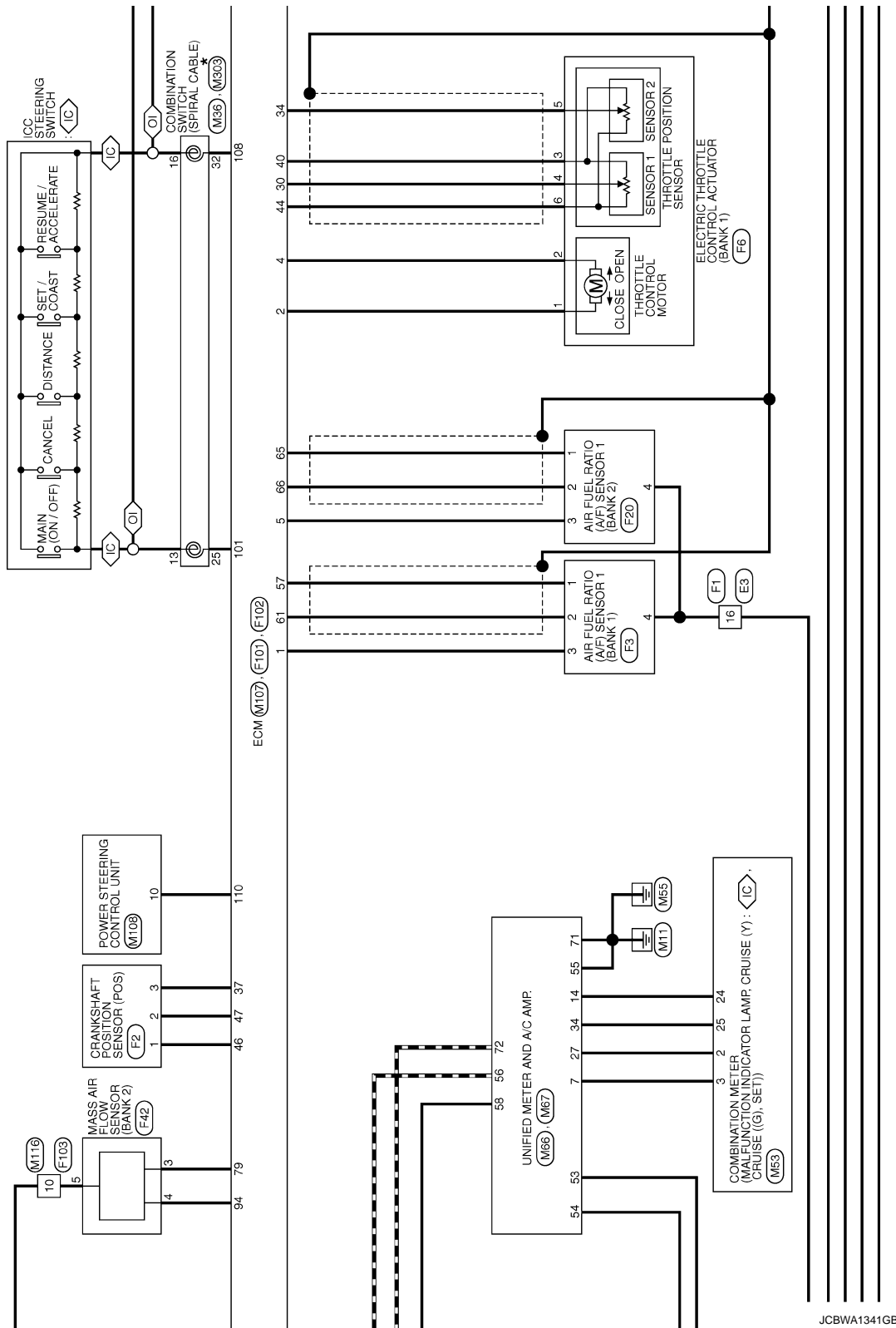

JCBWA1341GB

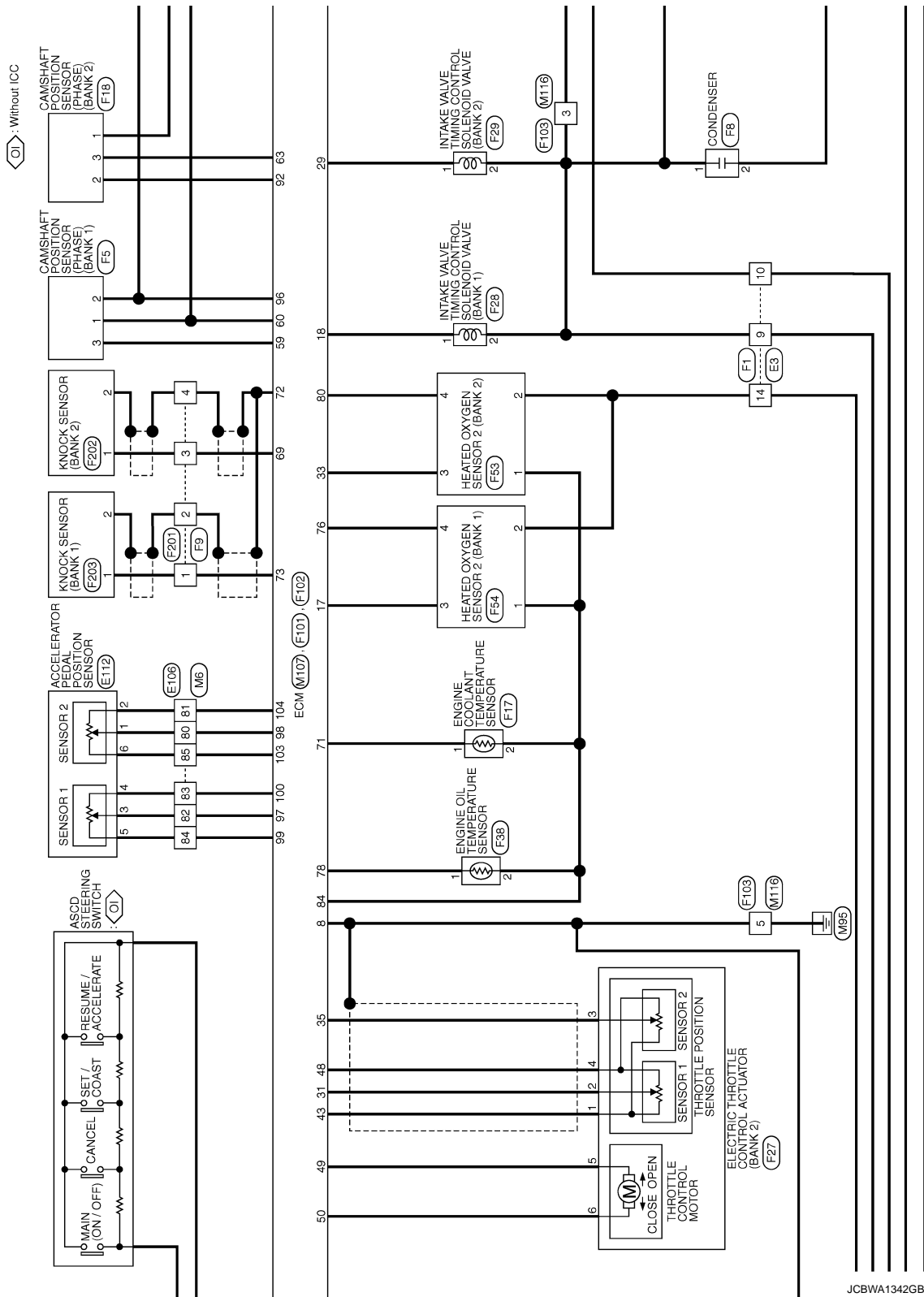

JCBWA1342GB

A
EC
C
D
E
F
G
H
I
J
K
L
M
N
O
P

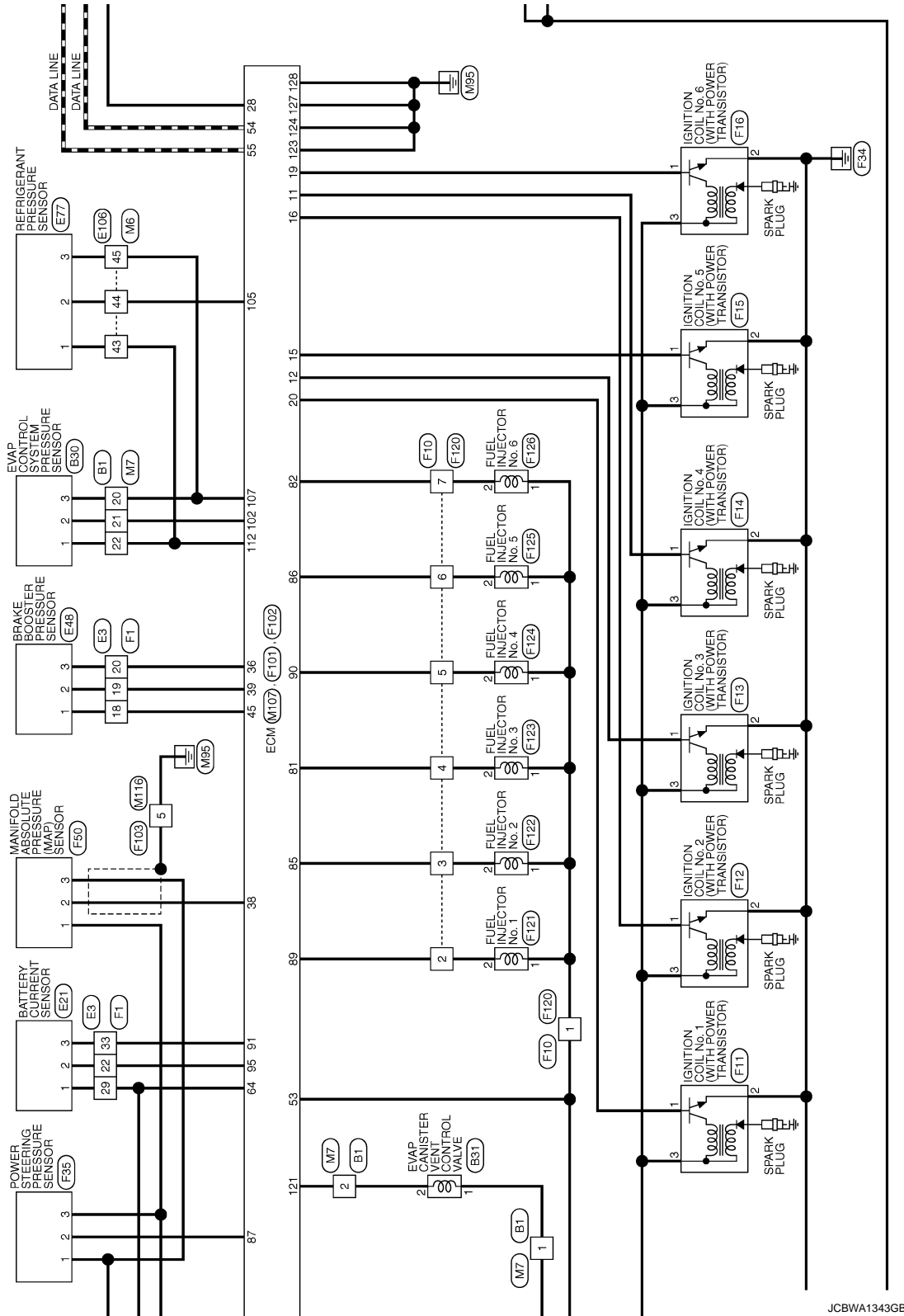

JCBWA1343GB

A

EC

C

D

E

F

G

H

I

J

K

L

M

N

O

P

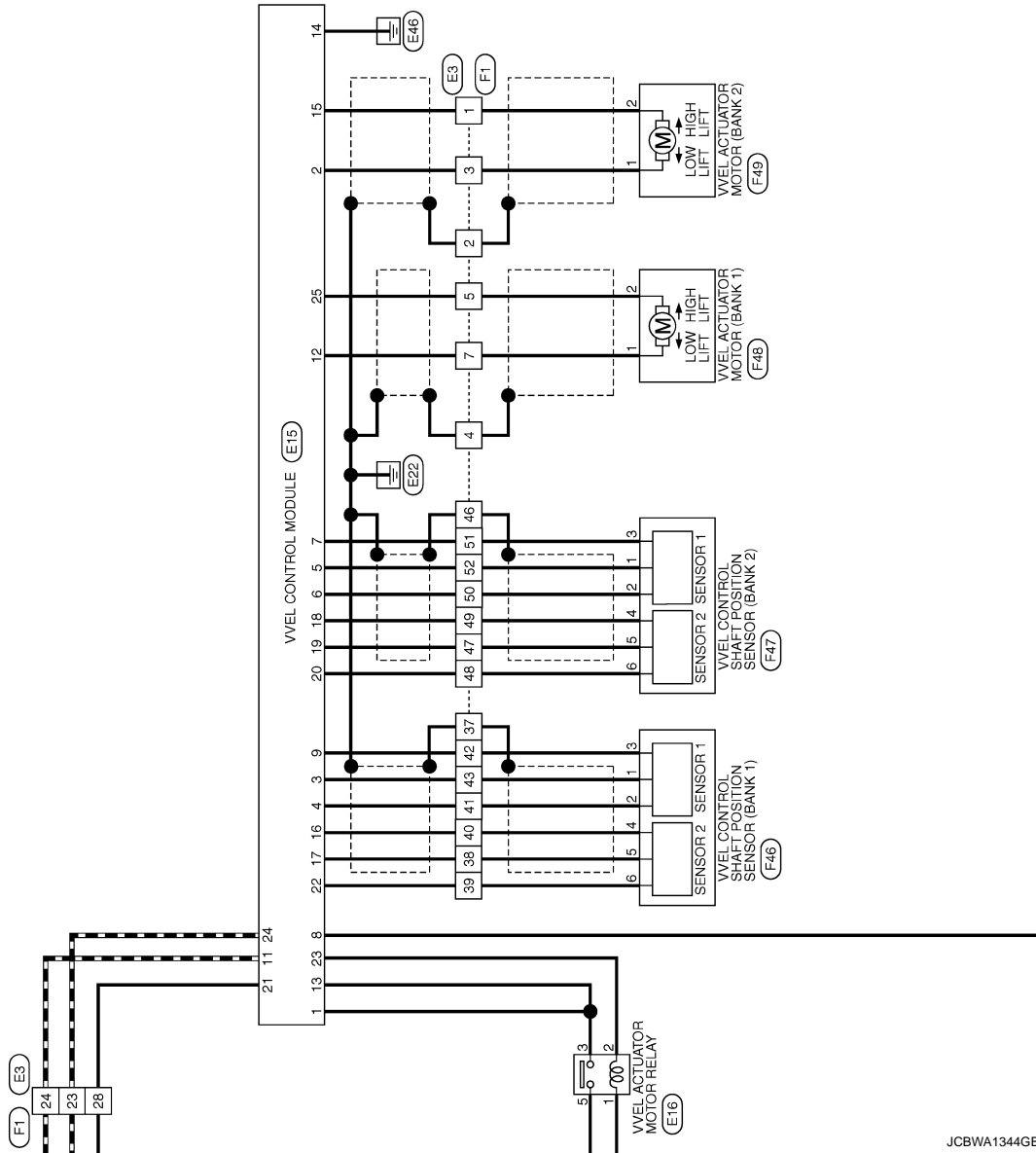

ENGINE CONTROL SYSTEM

Connector No.	B1
Connector Name	WIRE TO WIRE
Connector Type	THBDFW-GS16-TM4



Terminal No.	Color of Wire	Signal Name [Specification]
1	W	-
2	L	-
20	G	-
21	SB	-
22	GR	-
60	R	-
66	SB	-
67	P	-
68	L	-
69	P	-
70	L	-

Connector No.	B31
Connector Name	EVAP CANISTER VENT CONTROL VALVE
Connector Type	EOZFB-RS



Terminal No.	Color of Wire	Signal Name [Specification]
1	W	-
2	L	-

Connector No.	B9
Connector Name	WIRE TO WIRE
Connector Type	MOBEW-LC



Terminal No.	Color of Wire	Signal Name [Specification]
2	L	-

Connector No.	E3
Connector Name	WIRE TO WIRE
Connector Type	SAA38MB-RSP-SH28

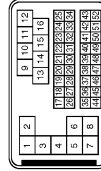

Terminal No.	Color of Wire	Signal Name [Specification]
1	L/Y	-
2	SHIELD	-
3	L/B	-
4	SHIELD	-
5	BR	-
7	G	-
9	W	-
10	Y	-
11	P	-
12	SB	-
14	G	-

Connector No.	B22
Connector Name	FUEL LEVEL SENSOR UNIT AND FUEL PUMP (MANI)
Connector Type	EOBFGY-RS



Terminal No.	Color of Wire	Signal Name [Specification]
1	L	-
3	B	-
4	R	-
5	SB	-

Terminal No.	Color of Wire	Signal Name [Specification]
16	LG	-
17	P	-
18	Y	-
19	O	-
20	B	-
22	W	-
23	L	-
24	G	-
27	GR	-
28	V	-
29	P	-
30	R	-
31	BR	-
33	G	-
34	O	-
37	SHIELD	-
38	L	-
39	P	-
40	R	-
41	W	-
42	LG	-
43	G	-
46	SHIELD	-
47	W	-
48	BR	-

Connector No.	B30
Connector Name	EVAP CONTROL SYSTEM PRESSURE SENSOR
Connector Type	EOBFGY-RS



Terminal No.	Color of Wire	Signal Name [Specification]
1	GR	-
2	SB	-
3	G	-

Terminal No.	Color of Wire	Signal Name [Specification]
49	C	-
50	B	-
51	SB	-
52	R	-

ENGINE CONTROL SYSTEM

Connector No.	E5
Connector Name	ENGINE INTELLIGENT POWER DISTRIBUTION MODULE (ENGINE ROOM)
Connector Type	TH20FW-CS12-IM4-IV

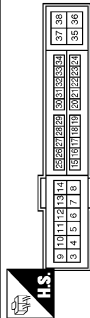

Terminal No.	Color of Wire	Signal Name [Specification]
12	B/W	-
13	Y	-

Connector No.	E6
Connector Name	ENGINE INTELLIGENT POWER DISTRIBUTION MODULE (ENGINE ROOM)
Connector Type	TH38FW-NH

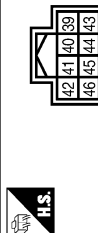

Terminal No.	Color of Wire	Signal Name [Specification]
39	P	-
40	L	-
41	B/W	-
42	Y	-

Connector No.	E7
Connector Name	ENGINE INTELLIGENT POWER DISTRIBUTION MODULE (ENGINE ROOM)
Connector Type	TH20FW-CS12-M4

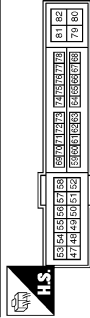

Terminal No.	Color of Wire	Signal Name [Specification]
48	BR	-
49	O	-
51	Y	-
53	W	-
54	P	-
55	SB	-
56	LG	-
57	G	-
69	BR	-
70	O	-
73	P	-

Connector No.	E9
Connector Name	ENGINE INTELLIGENT POWER DISTRIBUTION MODULE (ENGINE ROOM)
Connector Type	TH16FW-NH



Terminal No.	Color of Wire	Signal Name [Specification]
97	V	-

Connector No.	E15
Connector Name	VVEL CONTROL MODULE
Connector Type	RH18FB-AJ28-RH

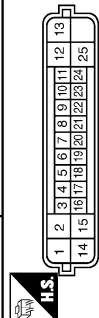

Terminal No.	Color of Wire	Signal Name [Specification]
1	W	VMOT L
2	L/B	MOTOR L 1
3	G	VEL/S-F1
4	W	AGND1
5	R	VEL/S-L1
6	B	AGND3
7	SB	AVCC3
8	O	V8
9	LG	AVCG1
11	G	CAN H
12	G	MOTOR R 1

Terminal No.	Color of Wire	Signal Name [Specification]
13	W	V-MOT (R)
14	B	PGND L
15	L/Y	MOTOR L 2
16	R	VEL-S-R2
17	L	AGND2
18	G	VEL-S-L2
19	W	AGND4
20	BR	AVCC4
21	V	ABORT
22	P	AVCC2
23	Y	M-RLY
24	L	CAN L
25	BR	MOTOR R 2

Connector No.	E16
Connector Name	VVEL ACTUATOR MOTOR RELAY
Connector Type	Z4347 3F500

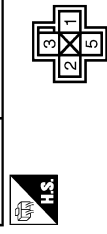

Terminal No.	Color of Wire	Signal Name [Specification]
1	R	-
2	Y	-
3	W	-
5	R	-

74	G
77	R

A
EC
C
D
E
F
G
H
I
J
K
L
M
N
O
P

JCBWA1346GB

ENGINE CONTROL SYSTEM

Connector No.	E17
Connector Name	COOLING FAN RELAY
Connector Type	24347-3F300



Terminal No.	Color of Wire	Signal Name [Specification]
1	Y	-
2	G	-
3	W	-
5	R	-

Connector No.	E21
Connector Name	BATTERY CURRENT SENSOR
Connector Type	RK03FB



Terminal No.	Color of Wire	Signal Name [Specification]
1	P	-
2	W	-
3	G	-

Connector No.	E37
Connector Name	COOLING FAN CONTROL MODULE
Connector Type	SJ201FGY-SNZZ



Terminal No.	Color of Wire	Signal Name [Specification]
1	B	-
2	V	-
3	R	-

Connector No.	E48
Connector Name	BRAKE BOOSTER PRESSURE SENSOR
Connector Type	RK03FB



Terminal No.	Color of Wire	Signal Name [Specification]
1	Y	-
2	O	-
3	B	-

Connector No.	E51
Connector Name	ICC BRAKE HOLD RELAY
Connector Type	MS2FL-MZ



Terminal No.	Color of Wire	Signal Name [Specification]
1	B	-
2	V	-
3	R	-
5	P	-

Connector No.	E67
Connector Name	ICC SENSOR INTEGRATED UNIT
Connector Type	RS06FB-PR



Terminal No.	Color of Wire	Signal Name [Specification]
2	V	BRAKE HOLD RLY DRIVE SIGNAL

Connector No.	E77
Connector Name	REFRIGERANT PRESSURE SENSOR
Connector Type	RK03FB



Terminal No.	Color of Wire	Signal Name [Specification]
1	V	-
2	L	-
3	O	-

Connector No.	E103
Connector Name	FUSE BLOCK (J/B)
Connector Type	NS16FY-CS



Terminal No.	Color of Wire	Signal Name [Specification]
2F	W	-
4F	G	-
8F	L	-

JCBWA1347GB

ENGINE CONTROL SYSTEM

Connector No.	E106
Connector Name	WIRE TO WIRE
Connector Type	THB07W-CS16-TM4

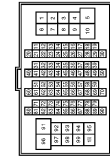

Terminal No.	Color of Wire	Signal Name [Specification]
7	O	-
31	P	-
32	L	-
43	V	-
44	L	-
45	O	-
66	GR	-
80	P	-
81	V	-
82	R	-
83	W	-

Connector No.	E110
Connector Name	STOP LAMP SWITCH
Connector Type	MDHFV-LC



Terminal No.	Color of Wire	Signal Name [Specification]
1	L	- [With ICC]
1	G	- [Without ICC]
2	SB	- [With ICC]
2	Y	- [Without ICC]
3	L	-
4	W	-

84	L	-
85	GR	-
87	SB	-

Connector No.	E108
Connector Name	ASCD CLUTCH SWITCH
Connector Type	SD2FL



Terminal No.	Color of Wire	Signal Name [Specification]
1	G	-
2	R	-

Connector No.	E112
Connector Name	ACCELERATOR PEDAL POSITION SENSOR
Connector Type	RH08FB



Terminal No.	Color of Wire	Signal Name [Specification]
1	P	-
2	V	-
3	R	-
4	W	-
5	L	-
6	GR	-

Connector No.	E109
Connector Name	ASCD BRAKE SWITCH
Connector Type	SD2FL



Terminal No.	Color of Wire	Signal Name [Specification]
1	G	- [With A/T]
1	R	- [With M/T]
2	SB	-

Connector No.	E114
Connector Name	ICC BRAKE SWITCH
Connector Type	SD2FL



Terminal No.	Color of Wire	Signal Name [Specification]
1	G	- [With A/T]
1	R	- [With M/T]
2	SB	-

A
EC
C
D
E
F
G
H
I
J
K
L
M
N
O
P

ENGINE CONTROL SYSTEM

Connector No.	E117
Connector Name	WIRE TO WIRE
Connector Type	MOBIMV-LC



Terminal No.	Color of Wire	Signal Name [Specification]
2	Y	-

Connector No.	E301
Connector Name	COOLING FAN CONTROL MODULE (COOLING FAN MOTOR-1)
Connector Type	6188-0259



Terminal No.	Color of Wire	Signal Name [Specification]
4	-	-
5	-	-

Connector No.	E302
Connector Name	COOLING FAN CONTROL MODULE (COOLING FAN MOTOR-2)
Connector Type	6188-0259



Terminal No.	Color of Wire	Signal Name [Specification]
6	-	-
7	-	-

Connector No.	F1
Connector Name	WIRE TO WIRE
Connector Type	SAA3PFB-RSS-SH2B

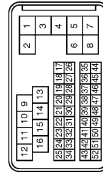

Terminal No.	Color of Wire	Signal Name [Specification]
1	L/Y	-
2	SHIELD	-
3	L/B	-
4	SHIELD	-
5	BR	-
7	G	-
9	W	-
10	G	-
11	B	-
12	P	-
14	LG	-

Terminal No.	Color of Wire	Signal Name [Specification]
49	O/L	-
50	L/Y	-
51	W	-
52	L/G	-

Connector No.	F2
Connector Name	CRANKSHAFT POSITION SENSOR (POS)
Connector Type	FR103FB



Terminal No.	Color of Wire	Signal Name [Specification]
1	R	-
2	Y	-
3	W	-

JCBWA1349GB

ENGINE CONTROL SYSTEM

Connector No.	F3
Connector Name	AIR FUEL RATIO (A/F) SENSOR 1 (BANK 1)
Connector Type	AEZMFDGY



Terminal No.	Color of Wire	Signal Name [Specification]
1	L	-
2	R	-
3	W	-
4	Y	-

Connector No.	F5
Connector Name	CRANKSHAF POSITION SENSOR PHASE (BANK 1)
Connector Type	RH03FB



Terminal No.	Color of Wire	Signal Name [Specification]
1	G	-
2	P	-
3	O	-

Connector No.	F6
Connector Name	ELECTRIC THROTTLE CONTROL ACTUATOR (BANK 1)
Connector Type	RH06FB



Terminal No.	Color of Wire	Signal Name [Specification]
1	G	MOTOR1-1
2	BR	MOTOR1-2
3	R	GND-A (TPS)
4	Y	TPS1-1
5	B	TPS2-1
6	L	AV/CC-TPS

Connector No.	F7
Connector Name	EVAP CANISTER PURGE VOLUME CONTROL SOLENOID VALVE
Connector Type	ED2FL-RS-LGY



Terminal No.	Color of Wire	Signal Name [Specification]
1	R	-
2	GR	-

Connector No.	F8
Connector Name	CONDENSER
Connector Type	MO2FW-LC



Terminal No.	Color of Wire	Signal Name [Specification]
1	W	-
2	B	-

Connector No.	F9
Connector Name	WIRE TO WIRE
Connector Type	RS04FL-B



Terminal No.	Color of Wire	Signal Name [Specification]
1	W	-
2	SHIELD	-
3	W	-
4	SHIELD	-

Connector No.	F10
Connector Name	WIRE TO WIRE
Connector Type	RH08FB



Terminal No.	Color of Wire	Signal Name [Specification]
1	G	-
2	GR	-
3	BR	-
4	R	-
5	O	-
6	W	-
7	V	-

Connector No.	F11
Connector Name	IGNITION COIL No. 1 (WITH POWER TRANSISTOR)
Connector Type	ED3FGY-RS



Terminal No.	Color of Wire	Signal Name [Specification]
1	Y	-
2	B	-
3	W	-

A
EC
C
D
E
F
G
H
I
J
K
L
M
N
O
P

ENGINE CONTROL SYSTEM

Connector No.	F12
Connector Name	IGNITION COIL No. 2 (WITH POWER TRANSISTOR)
Connector Type	EO3FGY-RS



Terminal No.	Color of Wire	Signal Name [Specification]
1	G	-
2	B	-
3	W	-

Connector No.	F13
Connector Name	IGNITION COIL No. 3 (WITH POWER TRANSISTOR)
Connector Type	EO3FGY-RS



Terminal No.	Color of Wire	Signal Name [Specification]
1	L	-
2	B	-
3	W	-

Connector No.	F14
Connector Name	IGNITION COIL No. 4 (WITH POWER TRANSISTOR)
Connector Type	EO3FGY-RS



Terminal No.	Color of Wire	Signal Name [Specification]
1	GR	-
2	B	-
3	W	-

Connector No.	F15
Connector Name	IGNITION COIL No. 5 (WITH POWER TRANSISTOR)
Connector Type	EO3FGY-RS



Terminal No.	Color of Wire	Signal Name [Specification]
1	V	-
2	B	-
3	W	-

Connector No.	F16
Connector Name	IGNITION COIL No. 6 (WITH POWER TRANSISTOR)
Connector Type	EO3FGY-RS



Terminal No.	Color of Wire	Signal Name [Specification]
1	SB	-
2	B	-
3	W	-

Connector No.	F17
Connector Name	ENGINE COOLANT TEMPERATURE SENSOR
Connector Type	EO2FGY-RS



Terminal No.	Color of Wire	Signal Name [Specification]
1	Y	-
2	B	-

Connector No.	F18
Connector Name	CRANKSHAF POSITION SENSOR (PHASE) (BANK 2)
Connector Type	RM03FB



Terminal No.	Color of Wire	Signal Name [Specification]
1	SB	-
2	G	-
3	L	-

Connector No.	F20
Connector Name	AIR FUEL RATIO (A/F) SENSOR 1 (BANK 2)
Connector Type	AFZ04FDGY



Terminal No.	Color of Wire	Signal Name [Specification]
1	LG	-
2	V	-
3	W	-
4	Y	-

JCBWA1351GB

ENGINE CONTROL SYSTEM

Connector No.	F27
Connector Name	ELECTRIC THROTTLE CONTROL ACTUATOR (BANK 2)
Connector Type	RH06FB



Terminal No.	Color of Wire	Signal Name [Specification]
1	G	-
2	R	-
3	W	-
4	B	-
5	GR	-
6	V	-

Connector No.	F28
Connector Name	INTAKE VALVE TIMING CONTROL SOLENOID VALVE (BANK 1)
Connector Type	ED2FG-RS-L0Y



Terminal No.	Color of Wire	Signal Name [Specification]
1	W	-
2	R	-

Connector No.	F29
Connector Name	INTAKE VALVE TIMING CONTROL SOLENOID VALVE (BANK 2)
Connector Type	ED2FG-RS-L0Y

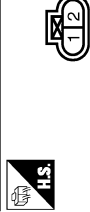

Terminal No.	Color of Wire	Signal Name [Specification]
1	G	-
2	R	-

Connector No.	F31
Connector Name	MASS AIR FLOW SENSOR (BANK 1)
Connector Type	RH06FB



Terminal No.	Color of Wire	Signal Name [Specification]
1	B	-
2	P	-
3	SB	-
4	LG	-
5	Y	-

Connector No.	F35
Connector Name	POWER STEERING PRESSURE SENSOR
Connector Type	RK03FB

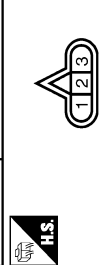

Terminal No.	Color of Wire	Signal Name [Specification]
1	LG	-
2	Y	-
3	R	-

Connector No.	F38
Connector Name	ENGINE OIL TEMPERATURE SENSOR
Connector Type	ED2FGY-RS

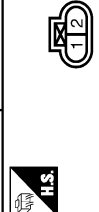

Terminal No.	Color of Wire	Signal Name [Specification]
1	G	-
2	B	-

Connector No.	F42
Connector Name	MASS AIR FLOW SENSOR (BANK 2)
Connector Type	RH06FB

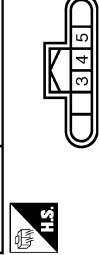

Terminal No.	Color of Wire	Signal Name [Specification]
3	BR	-
4	Y	-
5	GR	-

Connector No.	F48
Connector Name	LEVEL CONTROL SHIF POSITION SENSOR (BANK 1)
Connector Type	RH06FB

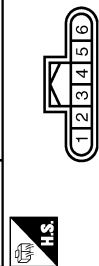

Terminal No.	Color of Wire	Signal Name [Specification]
1	R	-
2	B	-
3	GR	-
4	G	-
5	W	-
6	Y	-

JCBWA1352GB

A
EC
C
D
E
F
G
H
I
J
K
L
M
N
O
P

ENGINE CONTROL SYSTEM

Connector No.	F47
Connector Name	VEEL CONTROL SHAFT POSITION SENSOR (BANK 2)
Connector Type	RH08FB



Terminal No.	Color of Wire	Signal Name [Specification]
1	L/G	-
2	L/Y	-
3	W	-
4	O/L	-
5	W/L	-
6	LG	-

Connector No.	F48
Connector Name	VEEL ACTUATOR MOTOR (BANK 1)
Connector Type	X02FB



Terminal No.	Color of Wire	Signal Name [Specification]
1	G	-
2	BR	-

Connector No.	F49
Connector Name	VEEL ACTUATOR MOTOR (BANK 2)
Connector Type	X02FB



Terminal No.	Color of Wire	Signal Name [Specification]
1	L/B	-
2	L/Y	-

Connector No.	F50
Connector Name	MANIFOLD ABSOLUTE PRESSURE (MAP) SENSOR
Connector Type	RH08FB



Terminal No.	Color of Wire	Signal Name [Specification]
1	L	-
2	O	-
3	W	-

Connector No.	F51
Connector Name	A-T ASSEMBLY
Connector Type	RK10FG-D5Y

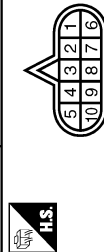

Terminal No.	Color of Wire	Signal Name [Specification]
3	L	-
8	P	-
9	GR	-

Connector No.	F53
Connector Name	HEATED OXYGEN SENSOR 2 (BANK 2)
Connector Type	AF204FB

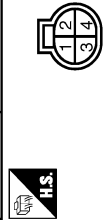

Terminal No.	Color of Wire	Signal Name [Specification]
1	B	-
2	LG	-
3	SB	-
4	O	-

Connector No.	F54
Connector Name	HEATED OXYGEN SENSOR 2 (BANK 1)
Connector Type	AF204FB



Terminal No.	Color of Wire	Signal Name [Specification]
1	B	-
2	R	-
3	P	-
4	W	-

Connector No.	F55
Connector Name	PARK / NEUTRAL POSITION SWITCH
Connector Type	RK02FB

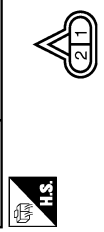

Terminal No.	Color of Wire	Signal Name [Specification]
1	BR	-
2	W	-

JCBWA1353GB

ENGINE CONTROL SYSTEM

Connector No.	F101
ECM	
Connector Name	ECM
Connector Type	RH40FB-R28-L-LH-Z

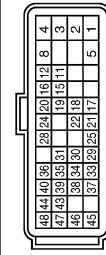

Terminal No.	Color of Wire	Signal Name [Specification]
1	W	AFH1/O2HF1
2	G	MOTOR1-B1
3	R	VMOT1-B1
4	BR	MOTOR2-B1
5	W	AFH2/O2HF2
8	B	GND
11	GR	IGN#4
12	L	IGN#3
15	V	IGN#5
16	G	IGN#2
17	P	O2HR1

Connector No.	F102
ECM	
Connector Name	ECM
Connector Type	RH40FB-R28-L-LH-Z

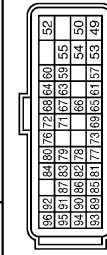

Terminal No.	Color of Wire	Signal Name [Specification]
49	GR	MOTOR2-B2
50	V	MOTOR1-B2
52	R	VMOT-B2
53	W	IGNSW
54	Y	ENG CAN-L1
55	LG	ENG CAN-H1
57	L	AF+1/O2SFI
58	O	PHASE#1
60	G	AVCC-PHS1-E-PHS1/PS
61	R	AF-J
63	L	PHASE#2

18	W	CVTCH1
19	SB	IGN#6
20	Y	IGN#1
21	GR	EVAP
22	R	EFR
24	P	SSOPF
25	O	MOTRLT-B1
28	BR	ABORT
29	G	CVTCH2
30	Y	TPST1-B1
31	R	TPST1-B2
33	SB	O2HR2
34	B	TPSZ-B1
35	W	TPSZ-B2
36	O	GND/INTPRES/MVPRES
37	W	POS
38	O	INTPRES1
39	P	MVPRES
40	R	GND/TPS-B1
43	G	AVCC-TPS-B2
44	L	AVCC-TPS-B1
45	LG	AVCCZ/INTPRES/MVPRES
46	R	AVCCZ-POS
47	Y	GND-POS
48	B	GND/TPS-B2

84	Y	GND/CA2/TA2
85	G	GND/CURSEN
96	P	GND/PHASE1/PS

Connector No.	F103
Connector Name	WIRE TO WIRE
Connector Type	TP38FW-NS10

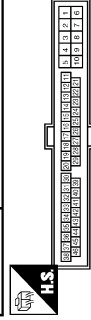

Terminal No.	Color of Wire	Signal Name [Specification]
3	W	-
4	R	-
5	B	-
9	Y	-
10	GR	-
42	BR	-
43	P	-
44	L	-

JCBWA1354GB

A
EC
C
D
E
F
G
H
I
J
K
L
M
N
O
P

ENGINE CONTROL SYSTEM

Connector No.	F120
Connector Name	WIRE TO WIRE
Connector Type	RH8BMB



Terminal No.	Color of Wire	Signal Name [Specification]
1	G	-
2	GR	-
3	BR	-
4	R	-
5	O	-
6	W	-
7	V	-

Connector No.	F121
Connector Name	FUEL INJECTOR No. 1
Connector Type	HS02FGY



Terminal No.	Color of Wire	Signal Name [Specification]
1	G	-
2	GR	-

Connector No.	F122
Connector Name	FUEL INJECTOR No. 2
Connector Type	HS02FGY



Terminal No.	Color of Wire	Signal Name [Specification]
1	G	-
2	BR	-

Connector No.	F123
Connector Name	FUEL INJECTOR No. 3
Connector Type	HS02FGY



Terminal No.	Color of Wire	Signal Name [Specification]
1	G	-
2	R	-

Connector No.	F124
Connector Name	FUEL INJECTOR No. 4
Connector Type	HS02FGY



Terminal No.	Color of Wire	Signal Name [Specification]
1	G	-
2	O	-

Connector No.	F125
Connector Name	FUEL INJECTOR No. 5
Connector Type	HS02FGY

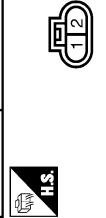

Terminal No.	Color of Wire	Signal Name [Specification]
1	G	-
2	W	-

Connector No.	F126
Connector Name	FUEL INJECTOR No. 6
Connector Type	HS02FGY

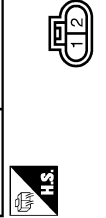

Terminal No.	Color of Wire	Signal Name [Specification]
1	G	-
2	V	-

Connector No.	F157
Connector Name	TGM (TRANSMISSION CONTROL MODULE)
Connector Type	SP10FG

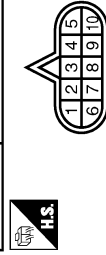

Terminal No.	Color of Wire	Signal Name [Specification]
3	R	CAN-H
8	BR	CAN-L
9	Y	STARTER RLY

ENGINE CONTROL SYSTEM

Connector No.	F201
Connector Name	WIRE TO WIRE
Connector Type	FSCMIL-B



Terminal No.	Color of Wire	Signal Name [Specification]
1	W	-
2	SHIELD	-
3	W	-
4	SHIELD	-

Connector No.	F202
Connector Name	KNOCK SENSOR (BANK 2)
Connector Type	ED2FG-RS-LGY



Terminal No.	Color of Wire	Signal Name [Specification]
1	W	-
2	SHIELD	-

Connector No.	F203
Connector Name	KNOCK SENSOR (BANK 1)
Connector Type	ED2FG-RS-LGY



Terminal No.	Color of Wire	Signal Name [Specification]
1	W	-
2	SHIELD	-

Connector No.	M1
Connector Name	FUSE BLOCK (J/B)
Connector Type	NS08FW-M2



Terminal No.	Color of Wire	Signal Name [Specification]
1A	V	-
2A	G	-

Connector No.	M2
Connector Name	FUSE BLOCK (J/B)
Connector Type	MS0FW-CS



Terminal No.	Color of Wire	Signal Name [Specification]
3B	P	-
6B	Y	-

Connector No.	M6
Connector Name	WIRE TO WIRE
Connector Type	TH80MW-CS (F-TM4)

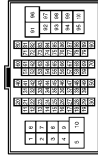

Terminal No.	Color of Wire	Signal Name [Specification]
7	R	-
31	P	-
32	L	-
43	W	-
44	L	-
45	O	-
66	GR	- [With A/T]
68	P	- [With M/T]
80	P	-
81	GR	-
82	R	-

Connector No.	M7
Connector Name	WIRE TO WIRE
Connector Type	TH80MW-CS (G-TM4)

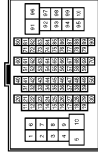



Terminal No.	Color of Wire	Signal Name [Specification]
1	O	-
2	LG	-
20	BR	-
21	G	-
22	R	-
60	W	-
66	Y	-
67	P	-
68	L	-
69	P	-
70	L	-

A
EC
C
D
E
F
G
H
I
J
K
L
M
N
O
P

ENGINE CONTROL SYSTEM

Connector No.	M35
Connector Name	COMBINATION SWITCH (SPIRAL CABLE)
Connector Type	TK08FGY-TV

Terminal No.	Color of Wire	Signal Name [Specification]
25	SB	-
32	Y	-

Connector No.	M24
Connector Name	DATA LINK CONNECTOR
Connector Type	BD16FW

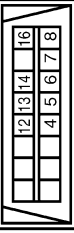

Terminal No.	Color of Wire	Signal Name [Specification]
4	B	-
5	BR	-
6	L	-
7	V	-
8	G	-
14	P	-
16	R	-

Connector No.	M67
Connector Name	UNIFIED METER AND A/C AMP.
Connector Type	TH42FW-NH

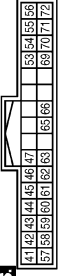
Terminal No.	Color of Wire	Signal Name [Specification]
53	W	IGNITION POWER SUPPLY
54	Y	BATTERY POWER SUPPLY
55	B	GROUND
56	L	CAN-H
58	Y	FUEL LEVEL SENSOR SIGNAL GROUND
71	GR	GROUND
72	P	CAN-L

Connector No.	M18
Connector Name	WIRE TO WIRE
Connector Type	TK02MW



Terminal No.	Color of Wire	Signal Name [Specification]
1	L	-
2	P	-

Connector No.	M66
Connector Name	UNIFIED METER AND A/C AMP.
Connector Type	TH40FW-NH





Terminal No.	Color of Wire	Signal Name [Specification]
7	GR	COMMUNICATION SIGNAL (METER->METER)
14	BR	COMMUNICATION SIGNAL (LGD->AMP)
27	LG	COMMUNICATION SIGNAL (METER->AMP)
34	Y	COMMUNICATION SIGNAL (AMP->LGD)

Connector No.	M17
Connector Name	WIRE TO WIRE
Connector Type	TK02FW

Terminal No.	Color of Wire	Signal Name [Specification]
1	L	-
2	P	-

Connector No.	M65
Connector Name	COMBINATION METER
Connector Type	SAB4FW

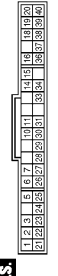
Terminal No.	Color of Wire	Signal Name [Specification]
2	LG	COMMUNICATION SIGNAL (METER->AMP)
3	GR	COMMUNICATION SIGNAL (AMP->METER)
24	BR	COMMUNICATION SIGNAL (LGD->AMP)
25	Y	COMMUNICATION SIGNAL (AMP->LGD)

JCBWA1357GB

A
EC
C
D
E
F
G
H
I
J
K
L
M
N
O
P

ENGINE CONTROL SYSTEM

Connector No.	M107
Connector Name	ECM
Connector Type	RHE4FGY-R26-R-LH-Z

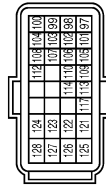

Terminal No.	Color of Wire	Signal Name [Specification]
97	R	APSI
98	P	APSZ
99	L	AVCC1-APSI
100	W	GND-APSI
101	SB	ASCDSW
102	G	FTRPS
103	G	AVCC2-APSZ
104	GR	GND-APSZ
105	L	PDPRESS
106	W	TF
107	BR	AVCC-PDPRES

Connector No.	M303
Connector Name	COMBINATION SWITCH (SPIRAL CABLE)
Connector Type	TK8BFGY



Terminal No.	Color of Wire	Signal Name [Specification]
13	-	-
16	-	-

108	Y	GND ASCDSW
109	G	NEUT-H
110	P	TACHO
112	P	GND-PDPRES
113	P	VEHCAN-LI
114	L	VEHCAN-HI
117	V	KLONE
121	LG	GDCV
122	P	BRAKE
123	B	GND
124	B	GND
125	R	VBR
126	BR	BNCSW
127	B	GND
128	B	GND

Connector No.	M108
Connector Name	POWER STEERING CONTROL UNIT
Connector Type	TH12FW-NH

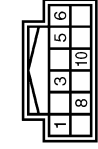

Terminal No.	Color of Wire	Signal Name [Specification]
10	R	TACHO

Connector No.	M116
Connector Name	WIRE TO WIRE
Connector Type	TK38MY-NS10



Terminal No.	Color of Wire	Signal Name [Specification]
3	O	-
4	R	-
5	B	-
9	R	-
10	R	-
42	G	-
43	P	-
44	L	-

Fail safe

NON DTC RELATED ITEM

JCBWA1358GB

INFOID:000000005152106

ECM

< ECU DIAGNOSIS INFORMATION >

[VQ37VHR]

Engine operating condition in fail-safe mode	Detected items	Remarks	Reference page
Engine speed will not rise more than 2,500 rpm due to the fuel cut	Malfunction indicator lamp circuit	When there is an open circuit on MIL circuit, the ECM cannot warn the driver by illuminating MIL when there is malfunction on engine control system. Therefore, when electrical controlled throttle and part of ECM related diagnoses are continuously detected as NG for 5 trips, ECM warns the driver that engine control system malfunctions and MIL circuit is open by means of operating the fail-safe function. The fail-safe function also operates when above diagnoses except MIL circuit are detected and demands the driver to repair the malfunction.	EC-508

DTC RELATED ITEM

DTC No.	Detected items	Engine operating condition in fail-safe mode	
U0113 U1003 U1024	Can communication circuit	VVEL actuator motor relay is turned off, and VVEL value is become at a minimum angle. Engine speed will not rise more than 3,500 rpm due to the fuel cut.	
P0011 P0021	Intake valve timing control	The signal is not energized to the intake valve timing control solenoid valve and the valve control does not function.	
P0102 P0103 P010C P010D	Mass air flow sensor circuit	Engine speed will not rise more than 2,400 rpm due to the fuel cut.	
P0117 P0118	Engine coolant temperature sensor circuit	Engine coolant temperature will be determined by ECM based on the following condition. CONSULT-III displays the engine coolant temperature decided by ECM.	
		Condition	Engine coolant temperature decided (CONSULT-III display)
		Just as ignition switch is turned ON or START	40°C (104°F)
		Approx 4 minutes or more after engine starting	80°C (176°F)
		Except as shown above	40 - 80°C (104 - 176°F) (Depends on the time)
		When the fail-safe system for engine coolant temperature sensor is activated, the cooling fan operates while engine is running.	
P0122 P0123 P0222 P0223 P0227 P0228 P1239 P2132 P2133 P2135	Throttle position sensor	The ECM controls the electric throttle control actuator in regulating the throttle opening in order for the idle position to be within +10 degrees. The ECM regulates the opening speed of the throttle valve to be slower than the normal condition. Therefore, the acceleration will be poor.	
P0500	Vehicle speed sensor	The cooling fan operates (Highest) while engine is running.	
P0524	Engine oil pressure	The signal is not energized to the intake valve timing control solenoid valve and the valve control does not function. Engine speed will not rise more than 2,400 rpm due to the fuel cut.	
P0605	ECM	(When ECM calculation function is malfunctioning:) ECM stops the electric throttle control actuator control, throttle valve is maintained at a fixed opening (approx. 5 degrees) by the return spring. ECM deactivates ASCD operation.	
P0607	ECM	VVEL actuator motor relay is turned off, and VVEL value is become at a minimum angle. Engine speed will not rise more than 2,500 rpm due to the fuel cut.	
P0643	Sensor power supply	ECM stops the electric throttle control actuator control, throttle valve is maintained at a fixed opening (approx. 5 degrees) by the return spring.	

ECM

< ECU DIAGNOSIS INFORMATION >

[VQ37VHR]

DTC No.	Detected items	Engine operating condition in fail-safe mode	
P1087 P1088	VVEL control function	VVEL of normal bank is controlled at VVEL angle of abnormal bank. Engine speed will not rise more than 3,500 rpm due to the fuel cut.	
P1089 P1092	VVEL control shaft position sensor	VVEL value is maintained at a fixed angle. Engine speed will not rise more than 3,500 rpm due to the fuel cut	
P1608	VVEL control shaft position sensor	VVEL actuator motor relay is turned off, and VVEL value is become at a minimam angle. Engine speed will not rise more than 3,500 rpm due to the fuel cut	
P1090 P1093	VVEL actuator motor	VVEL of normal bank is controlled at VVEL angle of abnormal bank. Engine speed will not rise more than 3,500 rpm due to the fuel cut.	
		VVEL actuator motor relay is turned off, and VVEL value is become at a minimam angle. Engine speed will not rise more than 3,500 rpm due to the fuel cut.	
P1091	VVEL actuator motor relay	VVEL actuator motor relay is turned off, and VVEL value is become at a minimam angle. Engine speed will not rise more than 3,500 rpm due to the fuel cut.	
P1233 P2101	Electric throttle control function	ECM stops the electric throttle control actuator control, throttle valve is maintained at a fixed opening (approx. 5 degrees) by the return spring.	
P1236 P2118	Throttle control motor	ECM stops the electric throttle control actuator control, throttle valve is maintained at a fixed opening (approx. 5 degrees) by the return spring.	
P1238 P2119	Electric throttle control actuator	(When electric throttle control actuator does not function properly due to the return spring malfunction:) ECM controls the electric throttle actuator by regulating the throttle opening around the idle position. The engine speed will not rise more than 2,000 rpm.	
		(When throttle valve opening angle in fail-safe mode is not in specified range:) ECM controls the electric throttle control actuator by regulating the throttle opening to 20 degrees or less.	
		(When ECM detects the throttle valve is stuck open:) While the vehicle is being driven, it slows down gradually because of fuel cut. After the vehicle stops, the engine stalls. The engine can restart in N or P position, and engine speed will not exceed 1,000 rpm or more.	
P1290 P2100 P2103	Throttle control motor relay	ECM stops the electric throttle control actuator control, throttle valve is maintained at a fixed opening (approx. 5 degrees) by the return spring.	
P1606	VVEL control module	VVEL actuator motor relay is turned off, and VVEL value is become at a minimam angle. Engine speed will not rise more than 3,500 rpm due to the fuel cut.	
P1805	Brake switch	ECM controls the electric throttle control actuator by regulating the throttle opening to a small range. Therefore, acceleration will be poor.	
		Vehicle condition	Driving condition
		When engine is idling	Normal
		When accelerating	Poor acceleration
P2122 P2123 P2127 P2128 P2138	Accelerator pedal position sensor	The ECM controls the electric throttle control actuator in regulating the throttle opening in order for the idle position to be within +10 degrees. The ECM regulates the opening speed of the throttle valve to be slower than the normal condition. Therefore, the acceleration will be poor.	

DTC Inspection Priority Chart

INFOID:000000005152107

If some DTCs are displayed at the same time, perform inspections one by one based on the following priority chart.

Priority	Detected items (DTC)
1	<ul style="list-style-type: none"> • U0101 U0113 U0164 U1001 U1003 CAN communication line • U1024 VVEL CAN communication line • P0101 P0102 P0103 P010B P010C P010D Mass air flow sensor • P010A Manifold absolute pressure (MAP) sensor • P0112 P0113 P0127 Intake air temperature sensor • P0117 P0118 P0125 Engine coolant temperature sensor • P0122 P0123 P0222 P0223 P0227 P0228 P1225 P1226 P1234 P1235 P1239 P2132 P2133 P2135 Throttle position sensor • P0128 Thermostat function • P0181 P0182 P0183 Fuel tank temperature sensor • P0196 P0197 P0198 Engine oil temperature sensor • P0327 P0328 P0332 P0333 Knock sensor • P0335 Crankshaft position sensor (POS) • P0340 P0345 Camshaft position sensor (PHASE) • P0460 P0461 P0462 P0463 Fuel level sensor • P0500 Vehicle speed sensor • P0555 Brake booster pressure sensor • P0605 P0607 ECM • P0643 Sensor power supply • P0705 P0850 Park/neutral position (PNP) switch (M/T) / Transumission range switch (A/T) • P1089 P1092 P1608 VVEL control shaft position sensor • P1550 P1551 P1552 P1553 P1554 Battery current sensor • P1606 P1607 VVEL control module • P1610 - P1615 NATS • P2122 P2123 P2127 P2128 P2138 Accelerator pedal position sensor
2	<ul style="list-style-type: none"> • P0031 P0032 P0051 P0052 Air fuel ratio (A/F) sensor 1 heater • P0037 P0038 P0057 P0058 Heated oxygen sensor 2 heater • P0075 P0081 Intake valve timing control solenoid valve • P0130 P0131 P0132 P0133 P0150 P0151 P0152 P0153 P2A00 P2A03 Air fuel ratio (A/F) sensor 1 • P0137 P0138 P0139 P0157 P0158 P0159 Heated oxygen sensor 2 • P0441 EVAP control system purge flow monitoring • P0443 P0444 P0445 EVAP canister purge volume control solenoid valve • P0447 P0448 EVAP canister vent control valve • P0451 P0452 P0453 EVAP control system pressure sensor • P0550 Power steering pressure sensor • P0603 ECM power supply • P0710 P0717 P0720 P0729 P0730 P0731 P0732 P0733 P0734 P0735 P0740 P0744 P0745 P0750 P0775 P0780 P0795 P1730 P1734 P2713 P2722 P2731 P2807 A/T related sensors, solenoid valves and switches • P1087 P1088 VVEL system • P1090 P1093 VVEL actuator motor • P1091 VVEL actuator motor relay • P1217 Engine over temperature (OVERHEAT) • P1233 P2101 Electric throttle control function • P1236 P2118 Throttle control motor • P1290 P2100 P2103 Throttle control motor relay • P1805 Brake switch
3	<ul style="list-style-type: none"> • P0011 P0021 Intake valve timing control • P0171 P0172 P0174 P0175 Fuel injection system function • P0300 - P0306 Misfire • P0420 P0430 Three way catalyst function • P0442 P0456 EVAP control system (SMALL LEAK, VERY SMALL LEAK) • P0455 EVAP control system (GROSS LEAK) • P0506 P0507 Idle speed control system • P0524 Engine oil pressure • P100A P100B VVEL system • P1148 P1168 Closed loop control • P1211 TCS control unit • P1212 TCS communication line • P1238 P2119 Electric throttle control actuator • P1421 Cold start control • P1564 ICC steering switch / ASCD steering switch • P1568 ICC command value • P1572 ICC brake switch / ASCD brake switch • P1574 ICC vehicle speed sensor / ASCD vehicle speed sensor

DTC Index

x:Applicable —: Not applicable

DTC*1		Items (CONSULT-III screen terms)	SRT code	Trip	MIL	Reference page
CONSULT-III GST*2	ECM*3					
U0101	0101*4	LOST COMM (TCM)	—	1	×	EC-145
U0113	0113	CAN COMM CIRCUIT	—	1 (A/T models) 2 (M/T models)	× (A/T models) — (M/T models)	EC-146
U0164	0164*4	LOST COMM (HVAC)	—	1	×	EC-148
U1001	1001*4	CAN COMM CIRCUIT	—	1 (with ASCD) 1 or 2 (with ICC)	—	EC-149
U1003	1003	CAN COMM CIRCUIT	—	2	—	EC-146
U1024	1024	VVEL CAN COMM CIRCUIT	—	1	×	EC-150
P0000	0000	NO DTC IS DETECTED. FURTHER TESTING MAY BE REQUIRED.	—	—	Flashing*7	—
P0011	0011	INT/V TIM CONT-B1	—	2	×	EC-152
P0021	0021	INT/V TIM CONT-B2	—	2	×	EC-152
P0031	0031	A/F SEN1 HTR (B1)	—	2	×	EC-156
P0032	0032	A/F SEN1 HTR (B1)	—	2	×	EC-156
P0037	0037	HO2S2 HTR (B1)	—	2	×	EC-159
P0038	0038	HO2S2 HTR (B1)	—	2	×	EC-159
P0051	0051	A/F SEN1 HTR (B2)	—	2	×	EC-156
P0052	0052	A/F SEN1 HTR (B2)	—	2	×	EC-156
P0057	0057	HO2S2 HTR (B2)	—	2	×	EC-159
P0058	0058	HO2S2 HTR (B2)	—	2	×	EC-159
P0075	0075	INT/V TIM V/CIR-B1	—	2	×	EC-162
P0081	0081	INT/V TIM V/CIR-B2	—	2	×	EC-162
P0101	0101	MAF SEN/CIRCUIT-B1	—	2	×	EC-165
P0102	0102	MAF SEN/CIRCUIT-B1	—	1	×	EC-172
P0103	0103	MAF SEN/CIRCUIT-B1	—	1	×	EC-172
P010A	010A	ABSL PRES SEN/CIRC	—	2	×	EC-178
P010B	010B	MAF SEN/CIRCUIT-B2	—	2	×	EC-165
P010C	010C	MAF SEN/CIRCUIT-B2	—	1	×	EC-172
P010D	010D	MAF SEN/CIRCUIT-B2	—	1	×	EC-172
P0112	0112	IAT SEN/CIRCUIT-B1	—	2	×	EC-182
P0113	0113	IAT SEN/CIRCUIT-B1	—	2	×	EC-182
P0117	0117	ECT SEN/CIRC	—	1	×	EC-187
P0118	0118	ECT SEN/CIRC	—	1	×	EC-187
P0122	0122	TP SEN 2/CIRC-B1	—	1	×	EC-190
P0123	0123	TP SEN 2/CIRC-B1	—	1	×	EC-190
P0125	0125	ECT SENSOR	—	2	×	EC-194
P0127	0127	IAT SENSOR-B1	—	2	×	EC-197
P0128	0128	THERMSTAT FNCTN	—	2	×	EC-199
P0130	0130	A/F SENSOR1 (B1)	—	2	×	EC-201
P0131	0131	A/F SENSOR1 (B1)	—	2	×	EC-205

ECM

< ECU DIAGNOSIS INFORMATION >

[VQ37VHR]

DTC*1		Items (CONSULT-III screen terms)	SRT code	Trip	MIL	Reference page
CONSULT-III GST*2	ECM*3					
P0132	0132	A/F SENSOR1 (B1)	—	2	×	EC-208
P0133	0133	A/F SENSOR1 (B1)	×	2	×	EC-211
P0137	0137	HO2S2 (B1)	×	2	×	EC-216
P0138	0138	HO2S2 (B1)	×	2	×	EC-222
P0139	0139	HO2S2 (B1)	×	2	×	EC-230
P0150	0150	A/F SENSOR1 (B2)	—	2	×	EC-201
P0151	0151	A/F SENSOR1 (B2)	—	2	×	EC-205
P0152	0152	A/F SENSOR1 (B2)	—	2	×	EC-208
P0153	0153	A/F SENSOR1 (B2)	×	2	×	EC-211
P0157	0157	HO2S2 (B2)	×	2	×	EC-216
P0158	0158	HO2S2 (B2)	×	2	×	EC-222
P0159	0159	HO2S2 (B2)	×	2	×	EC-230
P0171	0171	FUEL SYS-LEAN-B1	—	2	×	EC-236
P0172	0172	FUEL SYS-RICH-B1	—	2	×	EC-240
P0174	0174	FUEL SYS-LEAN-B2	—	2	×	EC-236
P0175	0175	FUEL SYS-RICH-B2	—	2	×	EC-240
P0181	0181	FTT SENSOR	—	2	×	EC-244
P0182	0182	FTT SEN/CIRCUIT	—	2	×	EC-247
P0183	0183	FTT SEN/CIRCUIT	—	2	×	EC-247
P0196	0196	EOT SENSOR	—	2	×	EC-250
P0197	0197	EOT SEN/CIRC	—	2	×	EC-253
P0198	0198	EOT SEN/CIRC	—	2	×	EC-253
P0222	0222	TP SEN 1/CIRC-B1	—	1	×	EC-256
P0223	0223	TP SEN 1/CIRC-B1	—	1	×	EC-256
P0227	0227	TP SEN 2/CIRC-B2	—	1	×	EC-190
P0228	0228	TP SEN 2/CIRC-B2	—	1	×	EC-190
P0300	0300	MULTI CYL MISFIRE	—	2	×	EC-260
P0301	0301	CYL 1 MISFIRE	—	2	×	EC-260
P0302	0302	CYL 2 MISFIRE	—	2	×	EC-260
P0303	0303	CYL 3 MISFIRE	—	2	×	EC-260
P0304	0304	CYL 4 MISFIRE	—	2	×	EC-260
P0305	0305	CYL 5 MISFIRE	—	2	×	EC-260
P0306	0306	CYL 6 MISFIRE	—	2	×	EC-260
P0327	0327	KNOCK SEN/CIRC-B1	—	2	—	EC-266
P0328	0328	KNOCK SEN/CIRC-B1	—	2	—	EC-266
P0332	0332	KNOCK SEN/CIRC-B2	—	2	—	EC-266
P0333	0333	KNOCK SEN/CIRC-B2	—	2	—	EC-266
P0335	0335	CKP SEN/CIRCUIT	—	2	×	EC-269
P0340	0340	CMP SEN/CIRC-B1	—	2	×	EC-273
P0345	0345	CMP SEN/CIRC-B2	—	2	×	EC-273
P0420	0420	TW CATALYST SYS-B1	×	2	×	EC-277
P0430	0430	TW CATALYST SYS-B2	×	2	×	EC-277

ECM

< ECU DIAGNOSIS INFORMATION >

[VQ37VHR]

DTC*1		Items (CONSULT-III screen terms)	SRT code	Trip	MIL	Reference page
CONSULT-III GST*2	ECM*3					
P0441	0441	EVAP PURG FLOW/MON	×	2	×	EC-282
P0442	0442	EVAP SMALL LEAK	×	2	×	EC-287
P0443	0443	PURG VOLUME CONT/V	—	2	×	EC-293
P0444	0444	PURG VOLUME CONT/V	—	2	×	EC-298
P0445	0445	PURG VOLUME CONT/V	—	2	×	EC-298
P0447	0447	VENT CONTROL VALVE	—	2	×	EC-301
P0448	0448	VENT CONTROL VALVE	—	2	×	EC-305
P0451	0451	EVAP SYS PRES SEN	—	2	×	EC-309
P0452	0452	EVAP SYS PRES SEN	—	2	×	EC-312
P0453	0453	EVAP SYS PRES SEN	—	2	×	EC-317
P0455	0455	EVAP GROSS LEAK	—	2	×	EC-323
P0456	0456	EVAP VERY SML LEAK	×*6	2	×	EC-329
P0460	0460	FUEL LEV SEN SLOSH	—	2	×	EC-336
P0461	0461	FUEL LEVEL SENSOR	—	2	×	EC-338
P0462	0462	FUEL LEVL SEN/CIRC	—	2	×	EC-340
P0463	0463	FUEL LEVL SEN/CIRC	—	2	×	EC-340
P0500	0500	VEH SPEED SEN/CIRC*5	—	2	×	EC-342
P0506	0506	ISC SYSTEM	—	2	×	EC-344
P0507	0507	ISC SYSTEM	—	2	×	EC-346
P0524	0524	ENGINE OIL PRESSURE	—	2	×	EC-348
P0550	0550	PW ST P SEN/CIRC	—	2	—	EC-351
P0555	0555	BRAKE BSTR PRES SEN/CIRC	—	2	×	EC-354
P0603	0603	ECM BACK UP/CIRCUIT	—	2	×	EC-359
P0605	0605	ECM	—	1 or 2	× or —	EC-361
P0607	0607	ECM	—	1 (A/T models) 2 (M/T models)	× (A/T models) — (M/T models)	EC-363
P0643	0643	SENSOR POWER/CIRC	—	1	×	EC-364
P0705	0705	T/M RANGE SENSOR A	—	2	×	TM-161
P0710	0710	FLUID TEMP SENSOR A	—	2	×	TM-162
P0717	0717	INPUT SPEED SENSOR A	—	2	×	TM-164
P0720	0720	OUTPUT SPEED SENSOR*5	—	2	×	TM-166
P0729	0729	6GR INCORRECT RATIO	—	2	×	TM-170
P0730	0730	INCORRECT GR RATIO	—	2	×	TM-172
P0731	0731	1GR INCORRECT RATIO	—	2	×	TM-173
P0732	0732	2GR INCORRECT RATIO	—	2	×	TM-175
P0733	0733	3GR INCORRECT RATIO	—	2	×	TM-177
P0734	0734	4GR INCORRECT RATIO	—	2	×	TM-179
P0735	0735	5GR INCORRECT RATIO	—	2	×	TM-181
P0740	0740	TORQUE COMVERTER	—	2	×	TM-183
P0744	0744	TORQUE COMVERTER	—	2	×	TM-185
P0745	0745	PC SOLENOID A	—	2	×	TM-186
P0750	0750	SHIFT SOLENOID A	—	2	×	TM-187

A

EC

C

D

E

F

G

H

I

J

K

L

M

N

O

P

ECM

< ECU DIAGNOSIS INFORMATION >

[VQ37VHR]

DTC*1		Items (CONSULT-III screen terms)	SRT code	Trip	MIL	Reference page
CONSULT-III GST*2	ECM*3					
P0775	0775	PC SOLENOID B	—	2	×	TM-188
P0780	0780	SHIFT	—	1	×	TM-189
P0795	0795	PC SOLENOID C	—	2	×	TM-190
P0850	0850	P-N POS SW/CIRCUIT	—	2	×	EC-367
P100A	100A	VVEL SYSTEM-B1	—	2	×	EC-371
P100B	100B	VVEL SYSTEM-B2	—	2	×	EC-371
P1087	1087	VVEL SYSTEM-B1	—	1	×	EC-375
P1088	1088	VVEL SYSTEM-B2	—	1	×	EC-375
P1089	1089	VVEL POS SEN/CIRC-B1	—	1	×	EC-376
P1090	1090	VVEL ACTR MOT-B1	—	1	×	EC-380
P1091	1091	VVEL ACTR MOT PWR	—	1 or 2	×	EC-384
P1092	1092	VVEL POS SEN/CIRC-B2	—	1	×	EC-376
P1093	1093	VVEL ACTR MOT-B2	—	1	×	EC-380
P1148	1148	CLOSED LOOP-B1	—	1	×	EC-387
P1168	1168	CLOSED LOOP-B2	—	1	×	EC-387
P1211	1211	TCS C/U FUNCTN	—	2	—	EC-388
P1212	1212	TCS/CIRC	—	2	—	EC-389
P1217	1217	ENG OVER TEMP	—	1	×	EC-390
P1225	1225	CTP LEARNING-B1	—	2	—	EC-394
P1226	1226	CTP LEARNING-B1	—	2	—	EC-396
P1233	1233	ETC FNCTN/CIRC-B2	—	1	×	EC-398
P1234	1234	CTP LEARNING-B2	—	2	—	EC-394
P1235	1235	CTP LEARNING-B2	—	2	—	EC-396
P1236	1236	ETC MOT-B2	—	1	×	EC-402
P1238	1238	ETC ACTR-B2	—	1	×	EC-405
P1239	1239	TP SENSOR-B2	—	1	×	EC-407
P1290	1290	ETC MOT PWR-B2	—	1	×	EC-410
P1421	1421	COLD START CONTROL	—	2	×	EC-412
P1550	1550	BAT CURRENT SENSOR	—	2	—	EC-414
P1551	1551	BAT CURRENT SENSOR	—	2	—	EC-417
P1552	1552	BAT CURRENT SENSOR	—	2	—	EC-417
P1553	1553	BAT CURRENT SENSOR	—	2	—	EC-420
P1554	1554	BAT CURRENT SENSOR	—	2	—	EC-423
P1564	1564	ASCD SW	—	1	—	EC-427 (with ASCD) EC-430 (with ICC)
P1568	1568	ICC COMMAND VALUE	—	1	—	EC-433
P1572	1572	ASCD BRAKE SW	—	1	—	EC-434 (with ASCD) EC-441 (with ICC)

ECM

< ECU DIAGNOSIS INFORMATION >

[VQ37VHR]

DTC*1		Items (CONSULT-III screen terms)	SRT code	Trip	MIL	Reference page
CONSULT-III GST*2	ECM*3					
P1574	1574	ASCD VHL SPD SEN	—	1	—	EC-449 (with ASCD) EC-451 (with ICC)
P1606	1606	VVEL CONTROL MODULE	—	1 or 2	× or —	EC-453
P1607	1607	VVEL CONTROL MODULE	—	1	×	EC-455
P1608	1608	VVEL SENSOR POWER/CIRC	—	1	×	EC-457
P1610	1610	LOCK MODE	—	2	—	SEC-30
P1611	1611	ID DISCARD IMM-ECM	—	2	—	SEC-31
P1612	1612	CHAIN OF ECM-IMMU	—	2	—	SEC-33
P1614	1614	CHAIN OF IMMU-KEY	—	2	—	SEC-34
P1615	1615	DIFFERENCE OF KEY	—	2	—	SEC-37
P1730	1730	INTERLOCK	—	2	×	TM-195
P1734	1734	7GR INCORRECT RATIO	—	2	×	TM-197
P1805	1805	BRAKE SW/CIRCUIT	—	2	—	EC-460
P2100	2100	ETC MOT PWR-B1	—	1	×	EC-410
P2101	2101	ETC FNCTN/CIRC-B1	—	1	×	EC-398
P2103	2103	ETC MOT PWR	—	1	×	EC-410
P2118	2118	ETC MOT-B1	—	1	×	EC-402
P2119	2119	ETC ACTR-B1	—	1	×	EC-405
P2122	2122	APP SEN 1/CIRC	—	1	×	EC-463
P2123	2123	APP SEN 1/CIRC	—	1	×	EC-463
P2127	2127	APP SEN 2/CIRC	—	1	×	EC-467
P2128	2128	APP SEN 2/CIRC	—	1	×	EC-467
P2132	2132	TP SEN 1/CIRC-B2	—	1	×	EC-256
P2133	2133	TP SEN 1/CIRC-B2	—	1	×	EC-256
P2135	2135	TP SENSOR-B1	—	1	×	EC-407
P2138	2138	APP SENSOR	—	1	×	EC-471
P2713	2713	PC SOLENOID D	—	2	×	TM-205
P2722	2722	PC SOLENOID E	—	2	×	TM-206
P2731	2731	PC SOLENOID F	—	2	×	TM-207
P2807	2807	PC SOLENOID G	—	2	×	TM-208
P2A00	2A00	A/F SENSOR1 (B1)	—	2	×	EC-476
P2A03	2A03	A/F SENSOR1 (B2)	—	2	×	EC-476

*1: 1st trip DTC No. is the same as DTC No.

*2: This number is prescribed by SAE J2012.

*3: In Diagnostic Test Mode II (Self-diagnostic results), this number is controlled by NISSAN.

*4: The troubleshooting for this DTC needs CONSULT-III.

*5: When the fail-safe operations for both self-diagnoses occur, the MIL illuminates.

*6: SRT code will not be set if the self-diagnostic result is NG.

*7: When the ECM is in the mode that displays SRT status, MIL may flash. For the details, refer to "How to Display SRT Status".

How to Set SRT Code

INFOID:000000005152109

To set all SRT codes, self-diagnosis for the items indicated above must be performed one or more times. Each diagnosis may require a long period of actual driving under various conditions.

WITH CONSULT-III

Perform corresponding DTC Confirmation Procedure one by one based on Performance Priority in the table on "SRT Item".

WITHOUT CONSULT-III

The most efficient driving pattern in which SRT codes can be properly set is explained below. The driving pattern should be performed one or more times to set all SRT codes.

DRIVING PATTERN

Note: Always drive vehicle in safe manner according to traffic conditions and obey all traffic laws. Refer to next page for more information and explanation of chart.

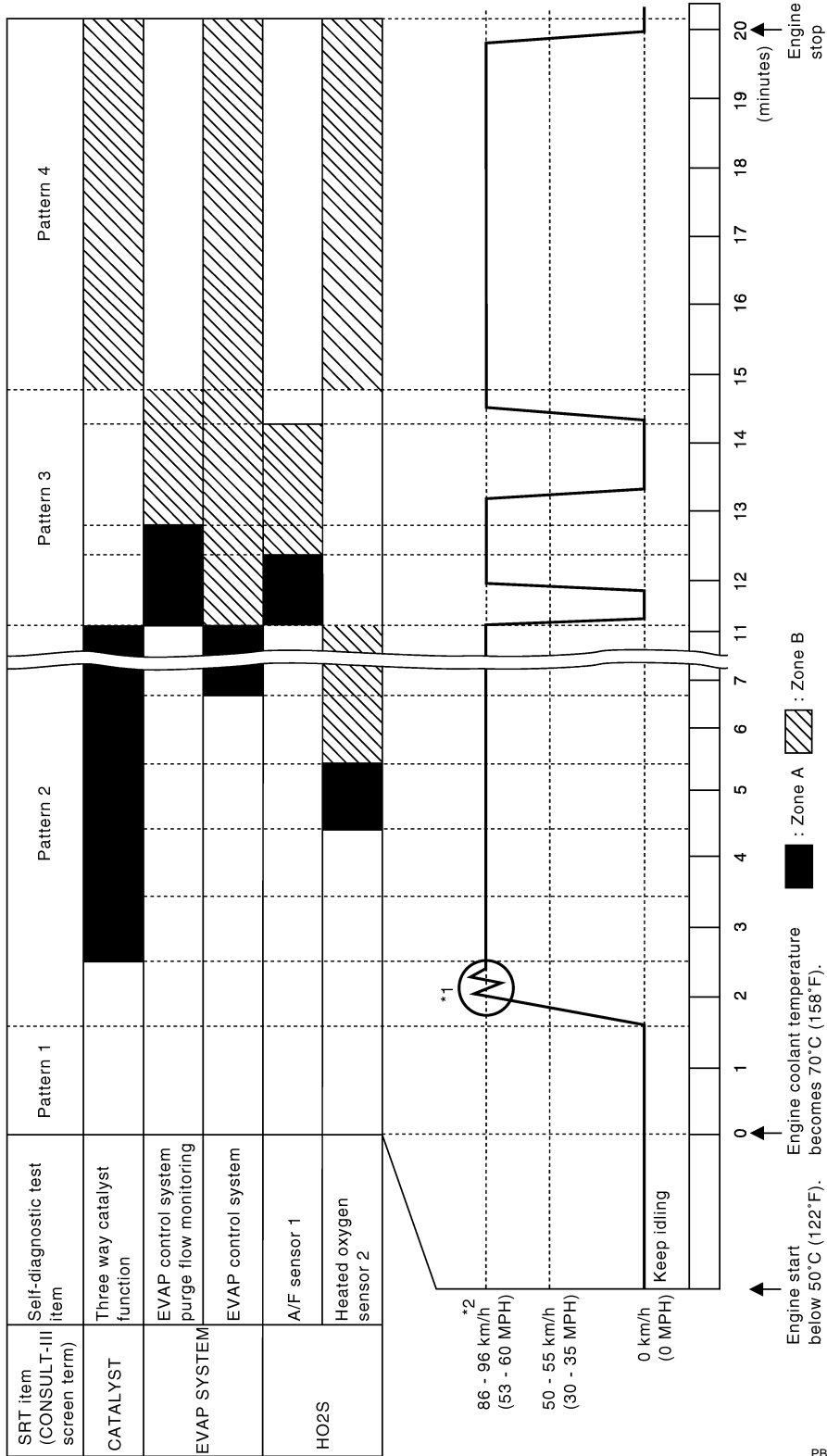

PBIB3455E

< ECU DIAGNOSIS INFORMATION >

- The time required for each diagnosis varies with road surface conditions, weather, altitude, individual driving habits, etc.
Zone A refers to the range where the time, required for the diagnosis under normal conditions*, is the shortest.
Zone B refers to the range where the diagnosis can still be performed if the diagnosis is not completed within zone A.

*: Normal conditions refer to the following:

- Sea level
- Flat road
- Ambient air temperature: 20 - 30°C (68 - 86°F)
- Diagnosis is performed as quickly as possible under normal conditions.
Under different conditions [For example: ambient air temperature other than 20 - 30°C (68 - 86°F)], diagnosis may also be performed.

Pattern 1:

- The engine is started at the engine coolant temperature of -10 to 35°C (14 to 95°F) [where the voltage between the ECM terminals 71 (engine coolant temperature signal) and 84 (sensor ground) is 3.0 - 4.3 V].**
- The engine must be operated at idle speed until the engine coolant temperature is greater than 70°C (158°F) [where the voltage between the ECM terminals 71 (engine coolant temperature signal) and 84 (sensor ground) is lower than 1.4 V].**
- The engine is started at the fuel tank temperature of warmer than 0°C (32°F) [where the voltage between the ECM terminals 106 (fuel temperature sensor signal) is less than 4.1 V].**

Pattern 2:

- When steady-state driving is performed again even after it is interrupted, each diagnosis can be conducted. In this case, the time required for diagnosis may be extended.

Pattern 3:

- Operate vehicle following the driving pattern shown in the figure.
- Release the accelerator pedal during deceleration vehicle speed from 90 km/h (56 MPH) to 0 km/h (0 MPH).

Pattern 4:

- The accelerator pedal must be held very steady during steady-state driving.
- If the accelerator pedal is moved, the test must be conducted again.

*1: Depress the accelerator pedal until vehicle speed is 90 km/h (56 MPH), then release the accelerator pedal and keep it released for more than 10 seconds. Depress the accelerator pedal until vehicle speed is 90 km/h (56 MPH) again.

*2: Checking the vehicle speed with GST is advised.

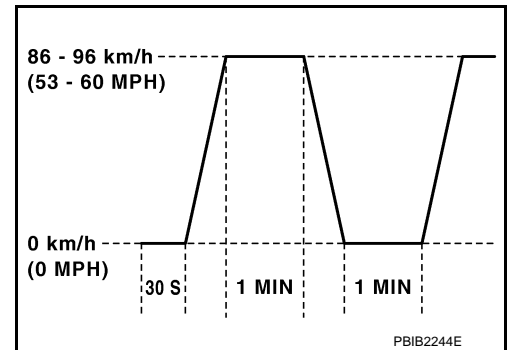

Suggested Transmission Gear Position for A/T Models

Set the selector lever in the D position with the overdrive switch turned ON.

Suggested Upshift Speeds for M/T Models

Shown below are suggested vehicle speeds for shifting into a higher gear. These suggestions relate to fuel economy and vehicle performance. Actual upshift speeds will vary according to road conditions, the weather and individual driving habits.

Unit: km/h (MPH)

Gear change	For normal acceleration in low altitude areas [less than 1,219 m (4,000 ft)]	For quick acceleration in low altitude areas or in high altitude areas [over 1,219 m (4,000 ft)]
1st to 2nd	13 (8)	24 (15)
2nd to 3rd	26 (16)	40 (25)
3rd to 4th	40 (25)	64 (40)
4th to 5th	50 (30)	72 (45)
5th to 6th	53 (33)	80 (50)

Suggested Maximum Speed in Each Gear

Downshift to a lower gear if the engine is not running smoothly, or if you need to accelerate.

Do not exceed the maximum suggested speed (shown below) in any gear. For level road driving, use the highest gear suggested for that speed. Always observe posted speed limits and drive according to the road condi-

ECM

< ECU DIAGNOSIS INFORMATION >

[VQ37VHR]

tions to ensure safe operation. Do not over-rev the engine when shifting to a lower gear as it may cause engine damage or loss of vehicle control.

Gear	km/h (MPH)
1st	63 (39)
2nd	103 (64)
3rd	148 (92)
4th	—
5th	—
6th	—

Test Value and Test Limit

INFOID:000000005152110

The following is the information specified in Service \$06 of SAE J1979.

The test value is a parameter used to determine whether a system/circuit diagnostic test is OK or NG while being monitored by the ECM during self-diagnosis. The test limit is a reference value which is specified as the maximum or minimum value and is compared with the test value being monitored.

These data (test value and test limit) are specified by On Board Monitor ID(OBDMID), Test ID (TID), Unit and Scaling ID and can be displayed on the GST screen.

The items of the test value and test limit will be displayed with GST screen which items are provided by the ECM. (eg., if bank 2 is not applied on this vehicle, only the items of bank 1 are displayed)

ECM

< ECU DIAGNOSIS INFORMATION >

[VQ37VHR]

Item	OBD-MID	Self-diagnostic test item	DTC	Test value and Test limit (GST display)		Description
				TID	Unit and Scaling ID	
HO2S	01H	Air fuel ratio (A/F) sensor 1 (Bank 1)	P0131	83H	0BH	Minimum sensor output voltage for test cycle
			P0131	84H	0BH	Maximum sensor output voltage for test cycle
			P0130	85H	0BH	Minimum sensor output voltage for test cycle
			P0130	86H	0BH	Maximum sensor output voltage for test cycle
			P0133	87H	04H	Response rate: Response ratio (Lean to Rich)
			P0133	88H	04H	Response rate: Response ratio (Rich to Lean)
			P2A00	89H	84H	The amount of shift in air fuel ratio
			P2A00	8AH	84H	The amount of shift in air fuel ratio
			P0130	8BH	0BH	Difference in sensor output voltage
			P0133	8CH	83H	Response gain at the limited frequency
	02H	Heated oxygen sensor 2 (Bank 1)	P0138	07H	0CH	Minimum sensor output voltage for test cycle
			P0137	08H	0CH	Maximum sensor output voltage for test cycle
			P0138	80H	0CH	Sensor output voltage
			P0139	81H	0CH	Difference in sensor output voltage
	03H	Heated oxygen sensor 3 (Bank 1)	P0143	07H	0CH	Minimum sensor output voltage for test cycle
P0144			08H	0CH	Maximum sensor output voltage for test cycle	
P0146			80H	0CH	Sensor output voltage	
P0145			81H	0CH	Difference in sensor output voltage	

A
EC
C
D
E
F
G
H
I
J
K
L
M
N
O
P

ECM

< ECU DIAGNOSIS INFORMATION >

[VQ37VHR]

Item	OBD-MID	Self-diagnostic test item	DTC	Test value and Test limit (GST display)		Description
				TID	Unit and Scaling ID	
HO2S	05H	Air fuel ratio (A/F) sensor 1 (Bank 2)	P0151	83H	0BH	Minimum sensor output voltage for test cycle
			P0151	84H	0BH	Maximum sensor output voltage for test cycle
			P0150	85H	0BH	Minimum sensor output voltage for test cycle
			P0150	86H	0BH	Maximum sensor output voltage for test cycle
			P0153	87H	04H	Response rate: Response ratio (Lean to Rich)
			P0153	88H	04H	Response rate: Response ratio (Rich to Lean)
			P2A03	89H	84H	The amount of shift in air fuel ratio
			P2A03	8AH	84H	The amount of shift in air fuel ratio
			P0150	8BH	0BH	Difference in sensor output voltage
			P0153	8CH	83H	Response gain at the limited frequency
	06H	Heated oxygen sensor 2 (Bank 2)	P0158	07H	0CH	Minimum sensor output voltage for test cycle
			P0157	08H	0CH	Maximum sensor output voltage for test cycle
			P0158	80H	0CH	Sensor output voltage
			P0159	81H	0CH	Difference in sensor output voltage
	07H	Heated oxygen sensor 3 (Bank2)	P0163	07H	0CH	Minimum sensor output voltage for test cycle
			P0164	08H	0CH	Maximum sensor output voltage for test cycle
			P0166	80H	0CH	Sensor output voltage
			P0165	81H	0CH	Difference in sensor output voltage
	CATA- LYST	21H	Three way catalyst function (Bank1)	P0420	80H	01H
P0420				82H	01H	Switching time lag engine exhaust index value
P2423				83H	0CH	Difference in 3rd O2 sensor output voltage
P2423				84H	84H	O2 storage index in HC trap catalyst
22H		Three way catalyst function (Bank2)	P0430	80H	01H	O2 storage index
			P0430	82H	01H	Switching time lag engine exhaust index value
			P2424	83H	0CH	Difference in 3rd O2 sensor output voltage
			P2424	84H	84H	O2 storage index in HC trap catalyst

ECM

< ECU DIAGNOSIS INFORMATION >

[VQ37VHR]

Item	OBD-MID	Self-diagnostic test item	DTC	Test value and Test limit (GST display)		Description
				TID	Unit and Scaling ID	
EGR SYSTEM	31H	EGR function	P0400	80H	96H	Low Flow Faults: EGR temp change rate (short term)
			P0400	81H	96H	Low Flow Faults: EGR temp change rate (long term)
			P0400	82H	96H	Low Flow Faults: Difference between max EGR temp and EGR temp under idling condition
			P0400	83H	96H	Low Flow Faults: Max EGR temp
			P1402	84H	96H	High Flow Faults: EGR temp increase rate
VVT SYSTEM	35H	VVT Monitor (Bank1)	P0011	80H	9DH	VTC intake function diagnosis (VTC alignment check diagnosis)
			P0014	81H	9DH	VTC exhaust function diagnosis (VTC alignment check diagnosis)
			P0011	82H	9DH	VTC intake function diagnosis (VTC drive failure diagnosis)
			P0014	83H	9DH	VTC exhaust function diagnosis (VTC drive failure diagnosis)
	36H	VVT Monitor (Bank2)	P0021	80H	9DH	VTC intake function diagnosis (VTC alignment check diagnosis)
			P0024	81H	9DH	VTC exhaust function diagnosis (VTC alignment check diagnosis)
			P0021	82H	9DH	VTC intake function diagnosis (VTC drive failure diagnosis)
			P0024	83H	9DH	VTC exhaust function diagnosis (VTC drive failure diagnosis)
EVAP SYSTEM	39H	EVAP control system leak (Cap Off)	P0455	80H	0CH	Difference in pressure sensor output voltage before and after pull down
	3BH	EVAP control system leak (Small leak)	P0442	80H	05H	Leak area index (for more than 0.04 inch)
	3CH	EVAP control system leak (Very small leak)	P0456	80H	05H	Leak area index (for more than 0.02 inch)
			P0456	81H	FDH	Maximum internal pressure of EVAP system during monitoring
	3DH	Purge flow system	P0441	83H	0CH	Difference in pressure sensor output voltage before and after vent control valve close
O2 SENSOR HEATER	41H	A/F sensor 1 heater (Bank 1)	Low Input:P0031 High Input:P0032	81H	0BH	Converted value of Heater electric current to voltage
	42H	Heated oxygen sensor 2 heater (Bank 1)	Low Input:P0037 High Input:P0038	80H	0CH	Converted value of Heater electric current to voltage
	43H	Heated oxygen sensor 3 heater (Bank 1)	P0043	80H	0CH	Converted value of Heater electric current to voltage
	45H	A/F sensor 1 heater (Bank 2)	Low Input:P0051 High Input:P0052	81H	0BH	Converted value of Heater electric current to voltage
	46H	Heated oxygen sensor 2 heater (Bank 2)	Low Input:P0057 High Input:P0058	80H	0CH	Converted value of Heater electric current to voltage
	47H	Heated oxygen sensor 3 heater (Bank 2)	P0063	80H	0CH	Converted value of Heater electric current to voltage

A

EC

C

D

E

F

G

H

I

J

K

L

M

N

O

P

ECM

< ECU DIAGNOSIS INFORMATION >

[VQ37VHR]

Item	OBD-MID	Self-diagnostic test item	DTC	Test value and Test limit (GST display)		Description
				TID	Unit and Scaling ID	
SEC- OND- ARY AIR	71H	Secondary Air system	P0411	80H	01H	Secondary Air Injection System Incorrect Flow Detected
			Bank1: P0491 Bank2: P0492	81H	01H	Secondary Air Injection System Insufficient Flow
			P2445	82H	01H	Secondary Air Injection System Pump Stuck Off
			P2448	83H	01H	Secondary Air Injection System High Airflow
			Bank1: P2440 Bank2: P2442	84H	01H	Secondary Air Injection System Switching Valve Stuck Open
			P2440	85H	01H	Secondary Air Injection System Switching Valve Stuck Open
			P2444	86H	01H	Secondary Air Injection System Pump Stuck On
FUEL SYSTEM	81H	Fuel injection system function (Bank 1)	P0171 or P0172	80H	2FH	Long term fuel trim
			P0171 or P0172	81H	24H	The number of lambda control clamped
	82H	Fuel injection system function (Bank 2)	P0174 or P0175	80H	2FH	Long term fuel trim
			P0174 or P0175	81H	24H	The number of lambda control clamped

ECM

< ECU DIAGNOSIS INFORMATION >

[VQ37VHR]

Item	OBD-MID	Self-diagnostic test item	DTC	Test value and Test limit (GST display)		Description
				TID	Unit and Scaling ID	
MISFIRE	A1H	Multiple Cylinder Misfires	P0301	80H	24H	Misfiring counter at 1000 revolution of the first cylinder
			P0302	81H	24H	Misfiring counter at 1000 revolution of the second cylinder
			P0303	82H	24H	Misfiring counter at 1000 revolution of the third cylinder
			P0304	83H	24H	Misfiring counter at 1000 revolution of the fourth cylinder
			P0305	84H	24H	Misfiring counter at 1000 revolution of the fifth cylinder
			P0306	85H	24H	Misfiring counter at 1000 revolution of the sixth cylinder
			P0307	86H	24H	Misfiring counter at 1000 revolution of the seventh cylinder
			P0308	87H	24H	Misfiring counter at 1000 revolution of the eighth cylinder
			P0300	88H	24H	Misfiring counter at 1000 revolution of the multiple cylinders
			P0301	89H	24H	Misfiring counter at 200 revolution of the first cylinder
			P0302	8AH	24H	Misfiring counter at 200 revolution of the second cylinder
			P0303	8BH	24H	Misfiring counter at 200 revolution of the third cylinder
			P0304	8CH	24H	Misfiring counter at 200 revolution of the fourth cylinder
			P0305	8DH	24H	Misfiring counter at 200 revolution of the fifth cylinder
			P0306	8EH	24H	Misfiring counter at 200 revolution of the sixth cylinder
			P0307	8FH	24H	Misfiring counter at 200 revolution of the seventh cylinder
			P0308	90H	24H	Misfiring counter at 200 revolution of the eighth cylinder
			P0300	91H	24H	Misfiring counter at 1000 revolution of the single cylinder
			P0300	92H	24H	Misfiring counter at 200 revolution of the single cylinder
			P0300	93H	24H	Misfiring counter at 200 revolution of the multiple cylinders

A
EC
C
D
E
F
G
H
I
J
K
L
M
N
O
P

ECM

< ECU DIAGNOSIS INFORMATION >

[VQ37VHR]

Item	OBD-MID	Self-diagnostic test item	DTC	Test value and Test limit (GST display)		Description
				TID	Unit and Scaling ID	
MISFIRE	A2H	No. 1 Cylinder Misfire	P0301	0BH	24H	EWMA (Exponential Weighted Moving Average) misfire counts for last 10 driving cycles
			P0301	0CH	24H	Misfire counts for last/current driving cycles
	A3H	No. 2 Cylinder Misfire	P0302	0BH	24H	EWMA (Exponential Weighted Moving Average) misfire counts for last 10 driving cycles
			P0302	0CH	24H	Misfire counts for last/current driving cycles
	A4H	No. 3 Cylinder Misfire	P0303	0BH	24H	EWMA (Exponential Weighted Moving Average) misfire counts for last 10 driving cycles
			P0303	0CH	24H	Misfire counts for last/current driving cycles
	A5H	No. 4 Cylinder Misfire	P0304	0BH	24H	EWMA (Exponential Weighted Moving Average) misfire counts for last 10 driving cycles
			P0304	0CH	24H	Misfire counts for last/current driving cycles
	A6H	No. 5 Cylinder Misfire	P0305	0BH	24H	EWMA (Exponential Weighted Moving Average) misfire counts for last 10 driving cycles
			P0305	0CH	24H	Misfire counts for last/current driving cycles
	A7H	No. 6 Cylinder Misfire	P0306	0BH	24H	EWMA (Exponential Weighted Moving Average) misfire counts for last 10 driving cycles
			P0306	0CH	24H	Misfire counts for last/current driving cycles
	A8H	No. 7 Cylinder Misfire	P0307	0BH	24H	EWMA (Exponential Weighted Moving Average) misfire counts for last 10 driving cycles
			P0307	0CH	24H	Misfire counts for last/current driving cycles
	A9H	No. 8 Cylinder Misfire	P0308	0BH	24H	EWMA (Exponential Weighted Moving Average) misfire counts for last 10 driving cycles
			P0308	0CH	24H	Misfire counts for last/current driving cycles

VVEL CONTROL MODULE

< ECU DIAGNOSIS INFORMATION >

[VQ37VHR]

VVEL CONTROL MODULE

Reference Value

INFOID:000000005152111

TERMINAL LAYOUT

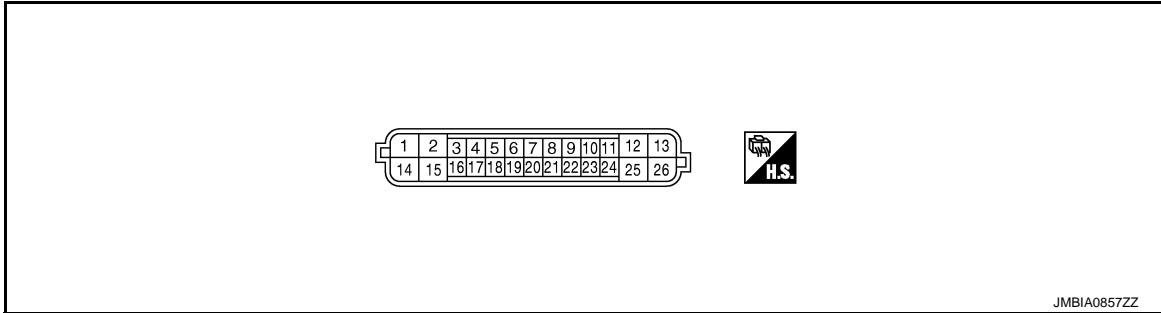

PHYSICAL VALUES

NOTE:

- VVEL control module is located behind the IPDM E/R. For this inspection, remove hoodledge cover (RH).
- Specification data are reference values and are measured between each terminal and ground.
- Pulse signal is measured by CONSULT-III.

Terminal No.		Description		Condition	Value (Approx.)
+	-	Signal name	Input/Output		
1 (W)	14 (B)	VVEL actuator motor power supply (bank 2)	Input	[Ignition switch: ON]	BATTERY VOLTAGE (11 - 14 V)
2 (L/B)	14 (B)	VVEL actuator motor (High lift) (bank 2)	Output	[Engine is running] <ul style="list-style-type: none"> • Warm-up condition • Idle speed 	0 - 14 V★ 5V/div JMBIA0854ZZ
				[Engine is running] <ul style="list-style-type: none"> • Warm-up condition • When revving engine up to 2,000 rpm quickly 	0 - 14 V★ 5V/div JMBIA0855ZZ
3 (G)	4 (W)	VVEL control shaft position sensor 2 (bank 1)	Input	[Engine is running] <ul style="list-style-type: none"> • Warm-up condition • Idle speed 	Approx.0.25 - 1.40 V
				[Engine is running] <ul style="list-style-type: none"> • Warm-up condition • When revving engine up to 2,000 rpm quickly 	Approx.0.25 - 4.75 V
4 (W)	-	Sensor ground [VVEL control shaft position sensor 2 (bank 1)]	-	-	-

VVEL CONTROL MODULE

< ECU DIAGNOSIS INFORMATION >

[VQ37VHR]

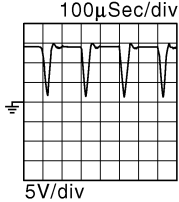
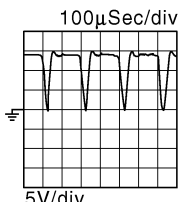
Terminal No.		Description		Condition	Value (Approx.)
+	-	Signal name	Input/Output		
5 (R)	6 (B)	VVEL control shaft position sensor 1 (bank 2)	Input	[Engine is running] • Warm-up condition • Idle speed	Approx.0.25 - 1.40 V
				[Engine is running] • Warm-up condition • When revving engine up to 2,000 rpm quickly	Approx.0.25 - 4.75 V
6 (B)	—	Sensor ground [VVEL control shaft position sensor 1 (bank 2)]	—	—	—
7 (SB)	6 (B)	Sensor power supply [VVEL control shaft position sensor 1 (bank 2)]	—	[Ignition switch: ON]	5 V
8 (O)	14 (B)	Power supply for VVEL control module	—	[Ignition switch: ON]	BATTERY VOLTAGE (11 - 14 V)
9 (LG)	4 (W)	Sensor power supply [VVEL control shaft position sensor 1 (bank 1)]	—	[Ignition switch: ON]	5 V
11 (G)	—	CAN communication line [ECM]	Input/Output	—	—
12 (G)	14 (B)	VVEL actuator motor (High lift) (bank 1)	Output	[Engine is running] • Warm-up condition • Idle speed	0 - 14 V★ 
				[Engine is running] • Warm-up condition • When revving engine up to 2,000 rpm quickly	0 - 14 V★ 
13 (W)	14 (B)	VVEL actuator motor power supply (bank 1)	Input	[Ignition switch: ON]	BATTERY VOLTAGE (11 - 14 V)
14 (B)	—	—	—	[Engine is running] • Idle speed	—

VVEL CONTROL MODULE

< ECU DIAGNOSIS INFORMATION >

[VQ37VHR]

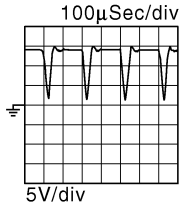
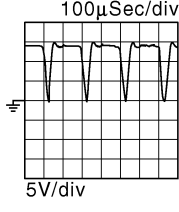
Terminal No.		Description		Condition	Value (Approx.)
+	-	Signal name	Input/Output		
15 (L/Y)	14 (B)	VVEL actuator motor (Low lift) (bank 2)	Output	[Engine is running] • Warm-up condition • Idle speed	0 - 14 V★ 
				[Engine is running] • Warm-up condition • When revving engine up to 2,000 rpm quickly	0 - 14 V★ 
16 (R)	17 (L)	VVEL control shaft position sensor 2 (bank 1)	Input	[Engine is running] • Warm-up condition • Idle speed	3.50 - 4.75 V
				[Engine is running] • Warm-up condition • When revving engine up to 2,000 rpm quickly	0.25 - 4.75 V
17 (L)	—	Sensor ground [VVEL control shaft position sensor 2 (bank 1)]	—	—	—
18 (G)	19 (W)	VVEL control shaft position sensor 2 (bank 2)	Input	[Engine is running] • Warm-up condition • Idle speed	3.50 - 4.75 V
				[Engine is running] • Warm-up condition • When revving engine up to 2,000 rpm quickly	0.25 - 4.75 V
19 (W)	—	Sensor ground [VVEL control shaft position sensor 2 (bank 2)]	—	—	—
20 (BR)	19 (W)	Sensor power supply [VVEL control shaft position sensor 2 (bank 2)]	—	[Ignition switch: ON]	5 V
21 (V)	14 (B)	VVEL actuator motor relay abort signal	Input	[Engine is running] • Warm-up condition • Idle speed	0 V
22 (P)	17 (L)	Sensor power supply [VVEL position sensor 2 (bank 1)]	—	[Ignition switch: ON]	5 V
23 (Y)	14 (B)	VVEL control motor relay	Output	[Ignition switch: OFF]	BATTERY VOLTAGE (11 - 14 V)
				[Ignition switch: ON]	0 - 1.0 V
24 (L)	—	CAN communication line	Input/Output	—	—

A
EC
C
D
E
F
G
H
I
J
K
L
M
N
O
P

VVEL CONTROL MODULE

< ECU DIAGNOSIS INFORMATION >

[VQ37VHR]

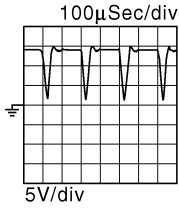
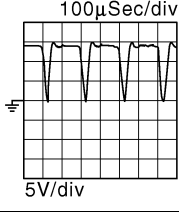
Terminal No.		Description		Condition	Value (Approx.)
+	-	Signal name	Input/Output		
25 (BR)	14 (B)	VVEL control motor (Low lift) (bank 1)	Output	[Engine is running] <ul style="list-style-type: none"> • Warm-up condition • Idle speed 	0 - 14 V★ 
				[Engine is running] <ul style="list-style-type: none"> • Warm-up condition • When revving engine up to 2,000 rpm quickly 	0 - 14 V★ 

★: Average voltage for pulse signal (Actual pulse signal can be confirmed by oscilloscope.)

VVEL CONTROL MODULE

< ECU DIAGNOSIS INFORMATION >

[VQ37VHR]

Wiring Diagram - ENGINE CONTROL SYSTEM -

INFOID:000000005152112

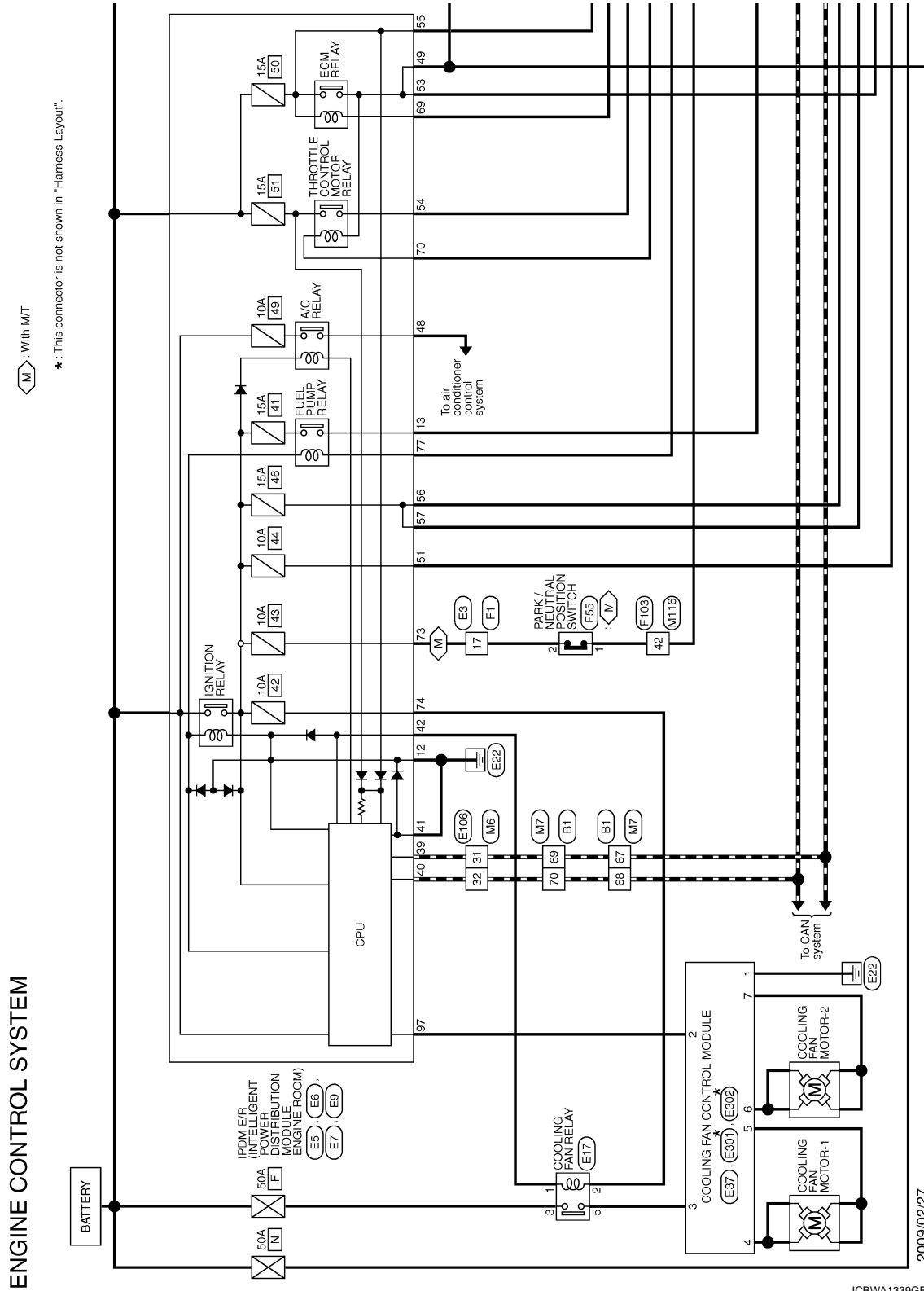

Ⓜ: With M/T

*: This connector is not shown in "Harness Layout".

A
EC
C
D
E
F
G
H
I
J
K
L
M
N
O
P

VVEL CONTROL MODULE

< ECU DIAGNOSIS INFORMATION >

[VQ37VHR]

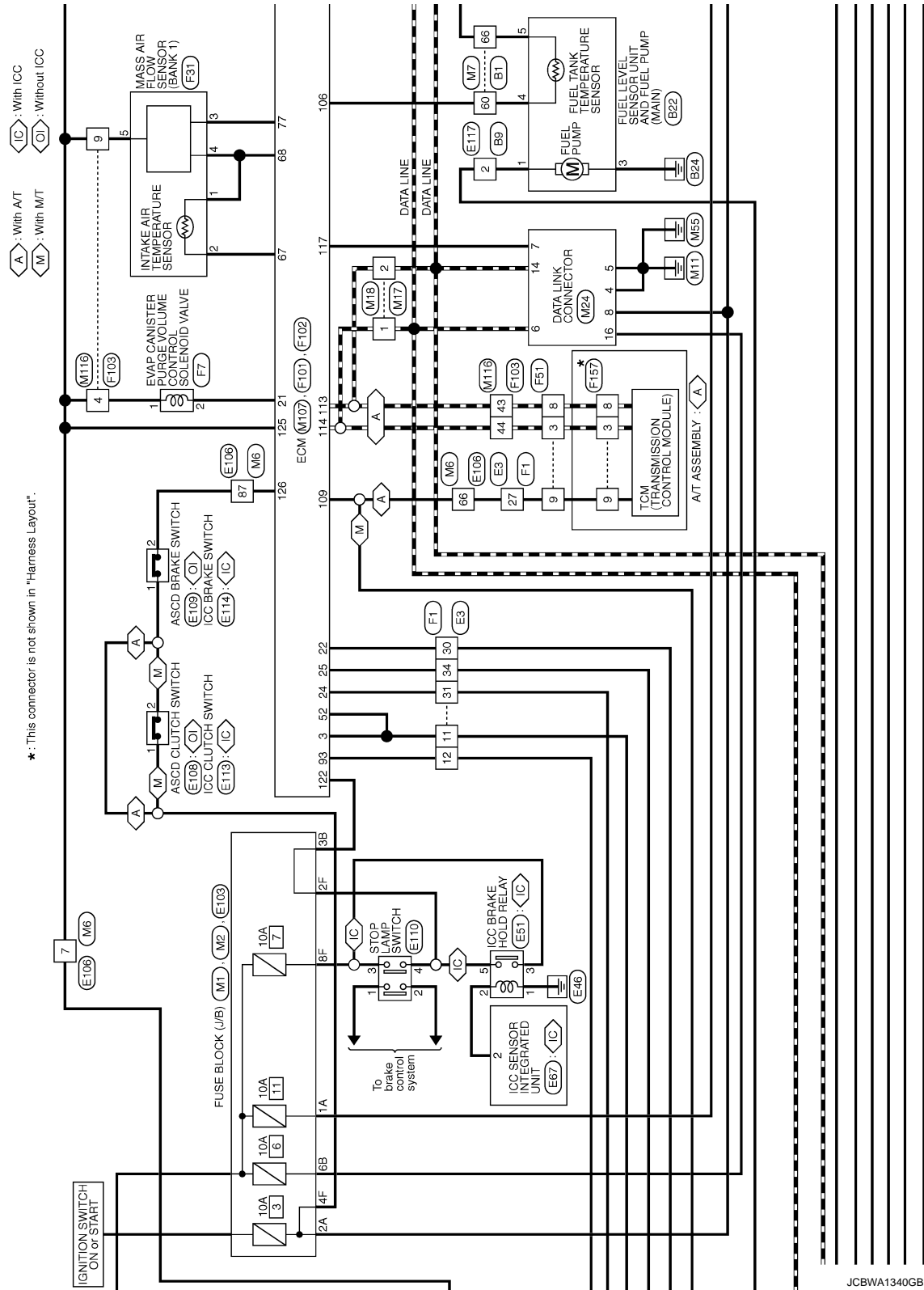

JCBWA1340GB

VVEL CONTROL MODULE

< ECU DIAGNOSIS INFORMATION >

[VQ37VHR]

*: This connector is not shown in "Harness Layout".

IC : With iCC
OI : Without iCC

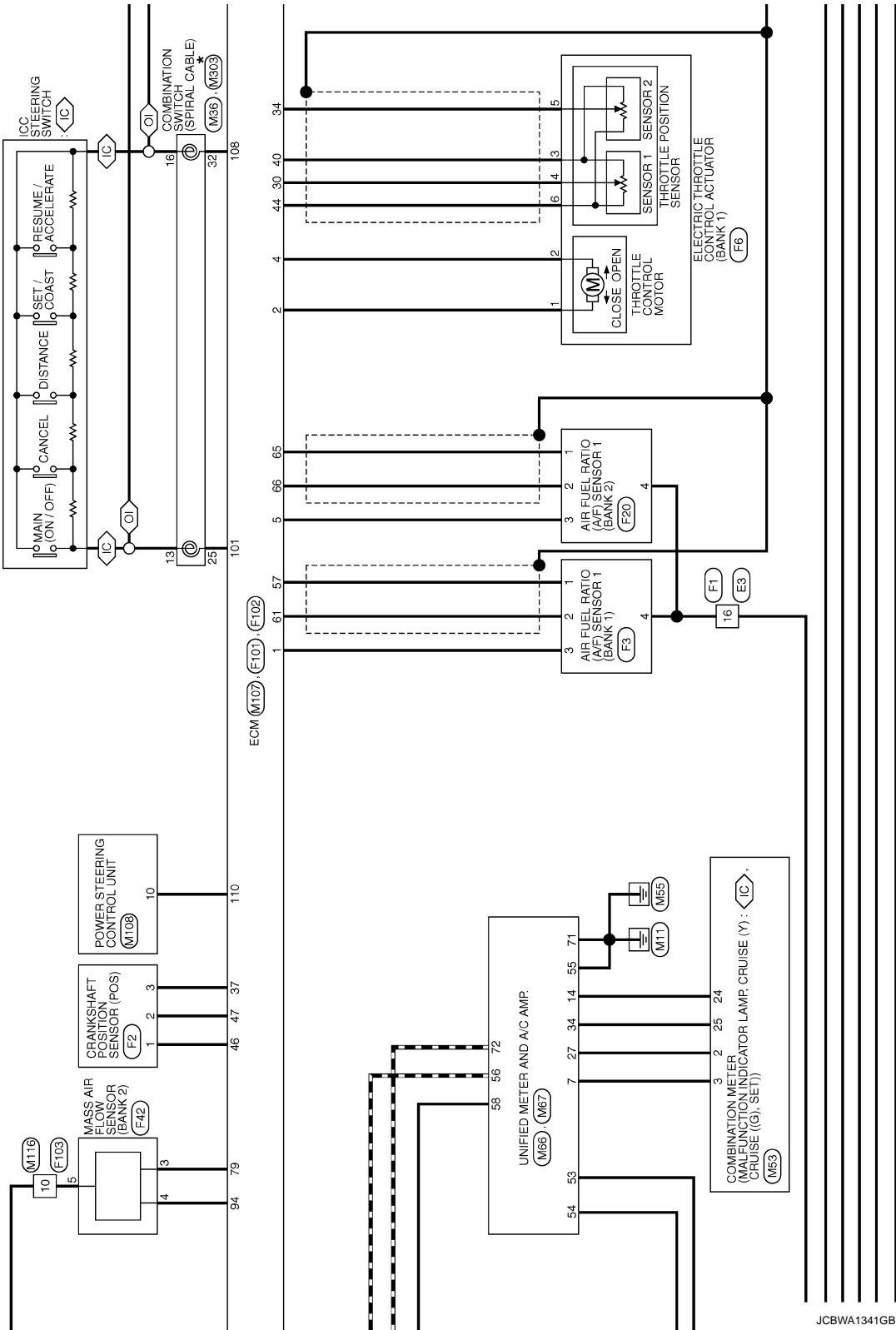

JCBWA1341GB

A
EC
C
D
E
F
G
H
I
J
K
L
M
N
O
P

VVEL CONTROL MODULE

< ECU DIAGNOSIS INFORMATION >

[VQ37VHR]

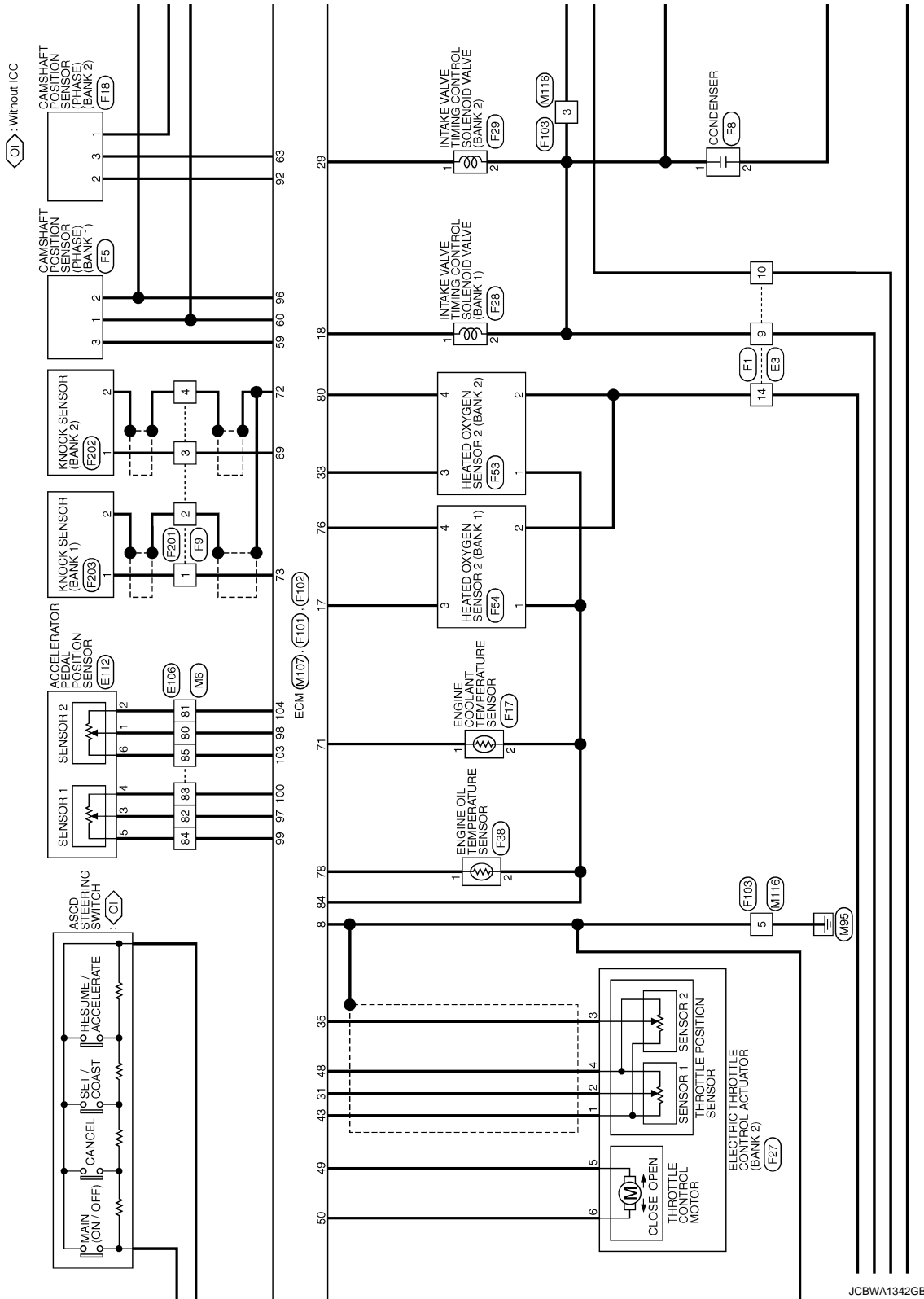

JCBWA1342GB

VVEL CONTROL MODULE

< ECU DIAGNOSIS INFORMATION >

[VQ37VHR]

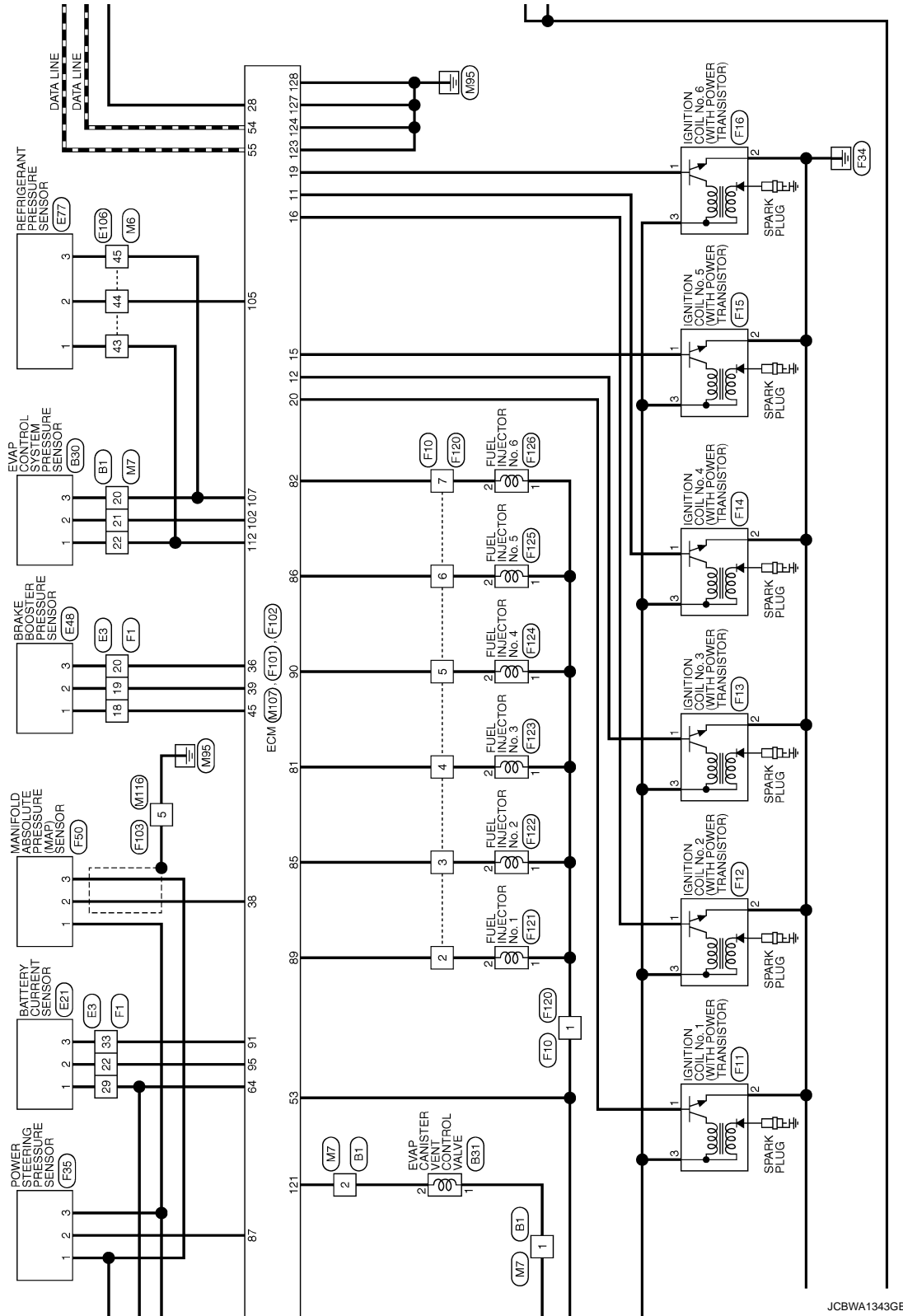

JCBWA1343GB

A
EC
C
D
E
F
G
H
I
J
K
L
M
N
O
P

VVEL CONTROL MODULE

< ECU DIAGNOSIS INFORMATION >

[VQ37VHR]

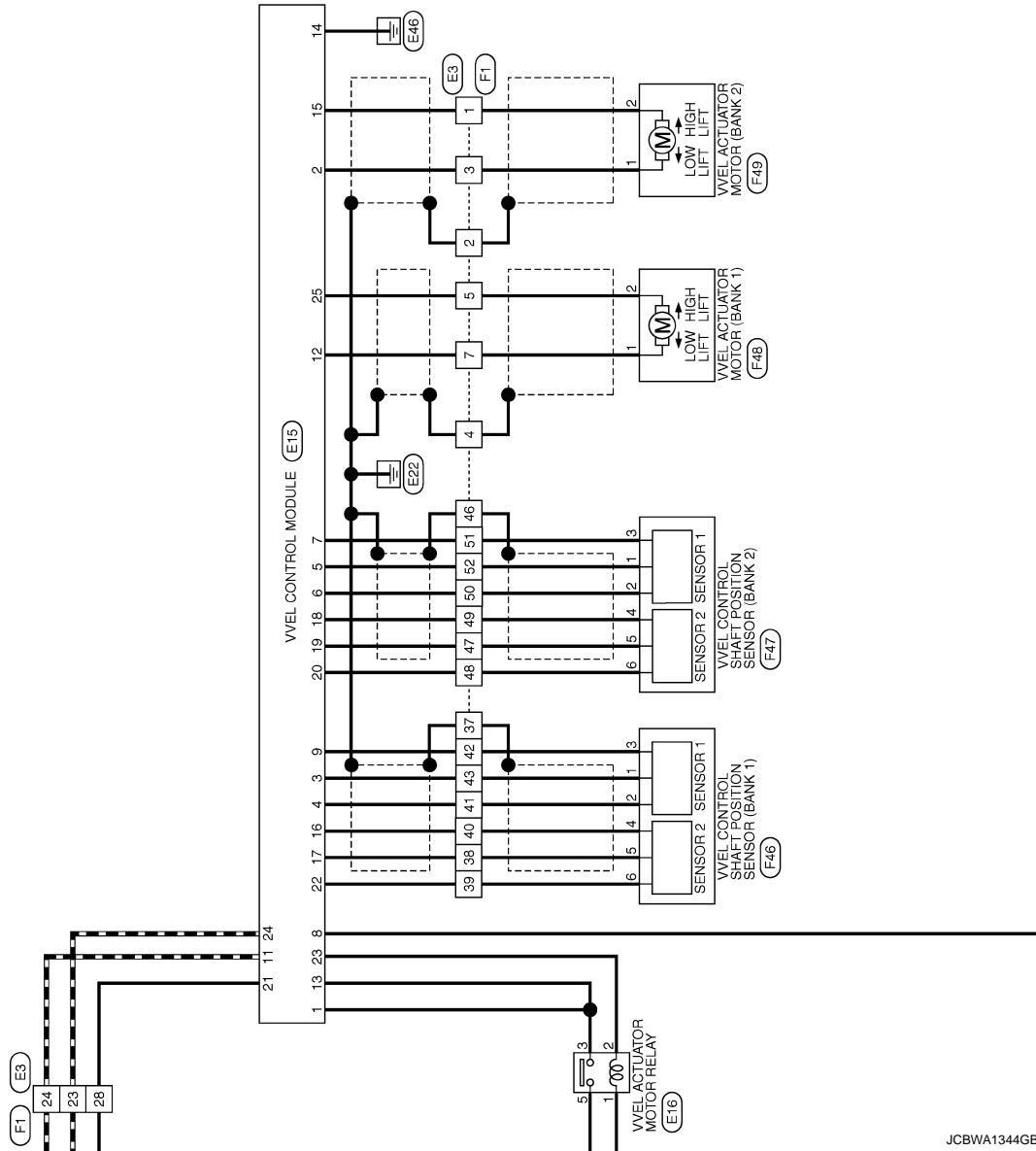

JCBWA1344GB

VVEL CONTROL MODULE

< ECU DIAGNOSIS INFORMATION >

[VQ37VHR]

ENGINE CONTROL SYSTEM

Connector No.	B1
Connector Name	WIRE TO WIRE
Connector Type	TH00FW-GS16-TM4

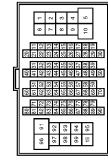

Terminal No.	Color of Wire	Signal Name [Specification]
1	W	-
2	L	-
20	G	-
21	SB	-
22	GR	-
60	R	-
66	SB	-
67	P	-
68	L	-
69	P	-
70	L	-

Connector No.	B31
Connector Name	EVAP CANISTER VENT CONTROL VALVE
Connector Type	EQ0FB-RS



Terminal No.	Color of Wire	Signal Name [Specification]
1	W	-
2	L	-

Connector No.	B0
Connector Name	WIRE TO WIRE
Connector Type	IM08FW-LC



Terminal No.	Color of Wire	Signal Name [Specification]
2	L	-

Connector No.	E3
Connector Name	WIRE TO WIRE
Connector Type	SA438MB-RSF-SH28



Terminal No.	Color of Wire	Signal Name [Specification]
1	L/Y	-
2	SHIELD	-
3	L/B	-
4	SHIELD	-
5	BR	-
7	G	-
8	W	-
10	Y	-
11	P	-
12	SB	-
14	G	-

Connector No.	B22
Connector Name	FUEL LEVEL SENSOR/LIMIT AND FUEL PUMP (MANI)
Connector Type	EQ0FBY-RS

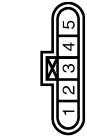

Terminal No.	Color of Wire	Signal Name [Specification]
1	L	-
3	B	-
4	R	-
5	SB	-

Terminal No.	Color of Wire	Signal Name [Specification]
16	LG	-
17	P	-
18	Y	-
19	O	-
20	B	-
22	W	-
23	L	-
24	G	-
27	GR	-
28	V	-
29	P	-
30	R	-
31	BR	-
33	G	-
34	O	-
37	SHIELD	-
38	L	-
39	P	-
40	R	-
41	W	-
42	LG	-
43	G	-
46	SHIELD	-
47	W	-
48	BR	-

Connector No.	B30
Connector Name	EVAP CONTROL SYSTEM PRESSURE SENSOR
Connector Type	EQ0FBY-RS



Terminal No.	Color of Wire	Signal Name [Specification]
1	GR	-
2	SB	-
3	G	-

Terminal No.	Color of Wire	Signal Name [Specification]
49	G	-
50	B	-
51	SB	-
52	R	-

A
EC
C
D
E
F
G
H
I
J
K
L
M
N
O
P

VVEL CONTROL MODULE

< ECU DIAGNOSIS INFORMATION >

[VQ37VHR]

ENGINE CONTROL SYSTEM

Connector No.	E5
Connector Name	ENGINE INTELLIGENT POWER DISTRIBUTION MODULE (ENGINE ROOM)
Connector Type	TH0DFW-GS12-MA-IV

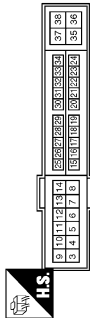

Terminal No.	Color of Wire	Signal Name [Specification]
12	B/W	-
13	Y	-

Connector No.	E6
Connector Name	ENGINE INTELLIGENT POWER DISTRIBUTION MODULE (ENGINE ROOM)
Connector Type	TH08FW-NH



Terminal No.	Color of Wire	Signal Name [Specification]
39	P	-
40	L	-
41	B/W	-
42	Y	-

Connector No.	E7
Connector Name	ENGINE INTELLIGENT POWER DISTRIBUTION MODULE (ENGINE ROOM)
Connector Type	TH20FW-CS12-M4

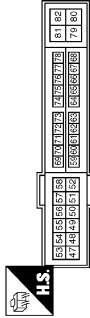

Terminal No.	Color of Wire	Signal Name [Specification]
48	BR	-
49	O	-
51	Y	-
53	W	-
54	P	-
55	SB	-
56	LG	-
57	G	-
69	BR	-
70	O	-
73	P	-

Connector No.	E8
Connector Name	ENGINE INTELLIGENT POWER DISTRIBUTION MODULE (ENGINE ROOM)
Connector Type	TH16FW-NH



Terminal No.	Color of Wire	Signal Name [Specification]
97	V	-

Connector No.	E15
Connector Name	VVEL CONTROL MODULE
Connector Type	RH18FB-AJ28-RH

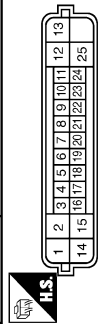

Terminal No.	Color of Wire	Signal Name [Specification]
1	W	VMOT L
2	L/B	MOTOR L 1
3	G	VEL/S-FI
4	W	AGND1
5	R	VEL/S-L1
6	B	AGND3
7	SB	AVCC3
8	O	VB
9	LG	AVCC1
11	G	CAN H
12	G	MOTOR R 1

Terminal No.	Color of Wire	Signal Name [Specification]
12	W	V-MOT (R)
14	B	RGND
15	L/Y	MOTOR L 2
16	R	VEL-S-F2
17	L	AGND2
18	G	VEL-S-L2
19	W	AGND4
20	BR	AVCC4
21	V	ABORT
22	P	AVCC2
23	Y	M-RLY
24	L	CAN L
25	BR	MOTOR R 2

Connector No.	E16
Connector Name	VVEL ACTUATOR MOTOR RELAY
Connector Type	Z4347 3F500



Terminal No.	Color of Wire	Signal Name [Specification]
1	R	-
2	Y	-
3	W	-
5	R	-

JCBWA1346GB

VVEL CONTROL MODULE

< ECU DIAGNOSIS INFORMATION >

[VQ37VHR]

ENGINE CONTROL SYSTEM

Connector No.	E17
Connector Name	COOLING FAN RELAY
Connector Type	24347-3F500



Terminal No.	Color of Wire	Signal Name [Specification]
1	Y	-
2	G	-
3	W	-
5	R	-

Connector No.	E21
Connector Name	BATTERY CURRENT SENSOR
Connector Type	RK03FB



Terminal No.	Color of Wire	Signal Name [Specification]
1	P	-
2	W	-
3	G	-

Connector No.	E27
Connector Name	COOLING FAN CONTROL MODULE
Connector Type	SJ201FGY-SNZZ



Terminal No.	Color of Wire	Signal Name [Specification]
1	B	-
2	V	-
3	R	-

Connector No.	E48
Connector Name	BRAKE BOOSTER PRESSURE SENSOR
Connector Type	RK03FB



Terminal No.	Color of Wire	Signal Name [Specification]
1	Y	-
2	O	-
3	B	-

Connector No.	E51
Connector Name	ICC BRAKE HOLD RELAY
Connector Type	MS2FL-WZ

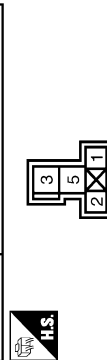

Terminal No.	Color of Wire	Signal Name [Specification]
1	B	-
2	V	-
3	R	-
5	P	-

Connector No.	E67
Connector Name	ICC SENSOR INTEGRATED UNIT
Connector Type	RS06FB-PR

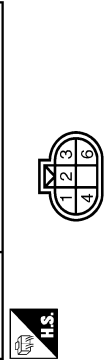

Terminal No.	Color of Wire	Signal Name [Specification]
2	V	BRAKE HOLD RELY DRIVE SIGNAL

Connector No.	E77
Connector Name	REFRIGERANT PRESSURE SENSOR
Connector Type	RK03FB

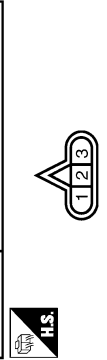

Terminal No.	Color of Wire	Signal Name [Specification]
1	V	-
2	L	-
3	O	-

Connector No.	E103
Connector Name	FUSE BLOCK (J/B)
Connector Type	NS16FY-CS

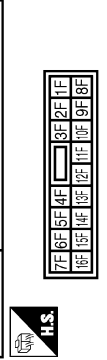

Terminal No.	Color of Wire	Signal Name [Specification]
2F	W	-
4F	G	-
8F	L	-

JCBWA1347GB

A
EC
C
D
E
F
G
H
I
J
K
L
M
N
O
P

VVEL CONTROL MODULE

< ECU DIAGNOSIS INFORMATION >

[VQ37VHR]

ENGINE CONTROL SYSTEM

Connector No.	E106
Connector Name	WIRE TO WIRE
Connector Type	THBDFW-GS16-TM4

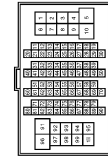

Terminal No.	Color of Wire	Signal Name [Specification]
7	O	-
31	P	-
32	L	-
43	V	-
44	L	-
45	O	-
66	GR	-
80	P	-
81	V	-
82	R	-
83	W	-

Connector No.	E110
Connector Name	STOP LAMP SWITCH
Connector Type	MD8FV-LC



Terminal No.	Color of Wire	Signal Name [Specification]
1	L	- [With ICC]
1	G	- [Without ICC]
2	SB	- [With ICC]
3	Y	- [Without ICC]
4	W	-

84	L	-
85	GR	-
87	SE	-

Connector No.	E108
Connector Name	ASCD CLUTCH SWITCH
Connector Type	SD2FL



Terminal No.	Color of Wire	Signal Name [Specification]
1	G	-
2	R	-

Connector No.	E109
Connector Name	ASCD BRAKE SWITCH
Connector Type	SD2FL



Terminal No.	Color of Wire	Signal Name [Specification]
1	G	- [With A/T]
1	R	- [With M/T]
2	SB	-

Connector No.	E112
Connector Name	ACCELERATOR PEDAL POSITION SENSOR
Connector Type	RN08FB



Terminal No.	Color of Wire	Signal Name [Specification]
1	P	-
2	V	-
3	R	-
4	W	-
5	L	-
6	GR	-

Connector No.	E113
Connector Name	ICC CLUTCH SWITCH
Connector Type	SD2FL



Terminal No.	Color of Wire	Signal Name [Specification]
1	G	-
2	R	-

Connector No.	E114
Connector Name	ICC BRAKE SWITCH
Connector Type	SD2FL



Terminal No.	Color of Wire	Signal Name [Specification]
1	G	- [With A/T]
2	R	- [With M/T]
2	SB	-

VVEL CONTROL MODULE

< ECU DIAGNOSIS INFORMATION >

[VQ37VHR]

ENGINE CONTROL SYSTEM

Connector No.	E117
Connector Name	WIRE TO WIRE
Connector Type	MOBAM-LC



Terminal No.	Color of Wire	Signal Name [Specification]
2	Y	-

Connector No.	E001
Connector Name	COOLING FAN CONTROL MODULE (COOLING FAN MOTOR-1)
Connector Type	6188-0259



Terminal No.	Color of Wire	Signal Name [Specification]
4	-	-
5	-	-

Connector No.	E002
Connector Name	COOLING FAN CONTROL MODULE (COOLING FAN MOTOR-2)
Connector Type	6188-0259



Terminal No.	Color of Wire	Signal Name [Specification]
6	-	-
7	-	-

Connector No.	F1
Connector Name	WIRE TO WIRE
Connector Type	SAA38FB-RSS-SH28

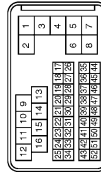

Terminal No.	Color of Wire	Signal Name [Specification]
1	L/Y	-
2	SHIELD	-
3	L/B	-
4	SHIELD	-
5	BR	-
7	G	-
9	W	-
10	G	-
11	R	-
12	P	-
14	LG	-

16	Y	-
17	W	-
18	LG	-
19	P	-
20	O	-
22	G	-
23	Y	-
24	LG	-
27	GR	-
28	BR	-
29	L	-
30	R	-
31	P	-
33	SB	-
34	O	-
37	B	-
38	W	-
39	Y	-
40	G	-
41	B	-
42	GR	-
43	R	-
46	SHIELD	-
47	W/L	-
48	LG	-

49	O/L	-
50	L/Y	-
51	W	-
52	L/G	-

Connector No.	F2
Connector Name	CRANKSHAFT POSITION SENSOR (POS)
Connector Type	FRU03FB



Terminal No.	Color of Wire	Signal Name [Specification]
1	R	-
2	Y	-
3	W	-

JCBWA1349GB

A
EC
C
D
E
F
G
H
I
J
K
L
M
N
O
P

VVEL CONTROL MODULE

< ECU DIAGNOSIS INFORMATION >

[VQ37VHR]

ENGINE CONTROL SYSTEM

Connector No.	F3
Connector Name	AIR FUEL RATIO (A/F) SENSOR 1 (BANK 1)
Connector Type	AEZ04FDGY



Terminal No.	Color of Wire	Signal Name [Specification]
1	L	-
2	R	-
3	W	-
4	Y	-

Connector No.	F5
Connector Name	CAVESHAF POSITION SENSOR (PHASE) (BANK 1)
Connector Type	RH03FB



Terminal No.	Color of Wire	Signal Name [Specification]
1	G	-
2	P	-
3	O	-

Connector No.	F6
Connector Name	ELECTRIC THROTTLE CONTROL ACTUATOR (BANK 1)
Connector Type	RH06FB



Terminal No.	Color of Wire	Signal Name [Specification]
1	G	MOTOR1-1
2	BR	MOTOR1-2
3	R	GND-A (TPS)
4	Y	TPS1-1
5	B	TPS2-1
6	L	AV/CC-TPS

Connector No.	F7
Connector Name	EVAP CANISTER PURGE VOLUME CONTROL SOLENOID VALVE
Connector Type	ED2FL-RS-LGY



Terminal No.	Color of Wire	Signal Name [Specification]
1	R	-
2	GR	-

Connector No.	F8
Connector Name	CONDENSER
Connector Type	MO2PW-LC



Terminal No.	Color of Wire	Signal Name [Specification]
1	W	-
2	B	-

Connector No.	F9
Connector Name	WIRE TO WIRE
Connector Type	RS04FL-B



Terminal No.	Color of Wire	Signal Name [Specification]
1	W	-
2	SHIELD	-
3	W	-
4	SHIELD	-

Connector No.	F10
Connector Name	WIRE TO WIRE
Connector Type	RH08FB



Terminal No.	Color of Wire	Signal Name [Specification]
1	G	-
2	GR	-
3	BR	-
4	R	-
5	O	-
6	W	-
7	V	-

Connector No.	F11
Connector Name	IGNITION COIL No. 1 (WITH POWER TRANSISTOR)
Connector Type	ED3FGY-RS



Terminal No.	Color of Wire	Signal Name [Specification]
1	Y	-
2	B	-
3	W	-

JCBWA1350GB

VVEL CONTROL MODULE

< ECU DIAGNOSIS INFORMATION >

[VQ37VHR]

ENGINE CONTROL SYSTEM

Connector No.	F12
Connector Name	IGNITION COIL No. 2 (WITH-POWER TRANSISTOR)
Connector Type	EOBFGY-RS



Terminal No.	Color of Wire	Signal Name [Specification]
1	G	-
2	B	-
3	W	-

Connector No.	F13
Connector Name	IGNITION COIL No. 3 (WITH-POWER TRANSISTOR)
Connector Type	EOBFGY-RS



Terminal No.	Color of Wire	Signal Name [Specification]
1	L	-
2	B	-
3	W	-

Connector No.	F14
Connector Name	IGNITION COIL No. 4 (WITH-POWER TRANSISTOR)
Connector Type	EOBFGY-RS



Terminal No.	Color of Wire	Signal Name [Specification]
1	GR	-
2	B	-
3	W	-

Connector No.	F15
Connector Name	IGNITION COIL No. 5 (WITH-POWER TRANSISTOR)
Connector Type	EOBFGY-RS



Terminal No.	Color of Wire	Signal Name [Specification]
1	V	-
2	B	-
3	W	-

Connector No.	F16
Connector Name	IGNITION COIL No. 6 (WITH-POWER TRANSISTOR)
Connector Type	EOBFGY-RS



Terminal No.	Color of Wire	Signal Name [Specification]
1	SB	-
2	B	-
3	W	-

Connector No.	F17
Connector Name	ENGINE COOLANT TEMPERATURE SENSOR
Connector Type	EOBFGY-RS



Terminal No.	Color of Wire	Signal Name [Specification]
1	Y	-
2	B	-

Connector No.	F18
Connector Name	CRANKSHAF POSITION SENSOR (PHASE) (BANK 2)
Connector Type	FR03FB



Terminal No.	Color of Wire	Signal Name [Specification]
1	SB	-
2	G	-
3	L	-

Connector No.	F20
Connector Name	AIR FUEL RATIO (A/F) SENSOR 1 (BANK 2)
Connector Type	AFZ04FDGY



Terminal No.	Color of Wire	Signal Name [Specification]
1	LG	-
2	V	-
3	W	-
4	Y	-

JCBWA1351GB

A
EC
C
D
E
F
G
H
I
J
K
L
M
N
O
P

VVEL CONTROL MODULE

< ECU DIAGNOSIS INFORMATION >

[VQ37VHR]

ENGINE CONTROL SYSTEM

Connector No.	F27
Connector Name	ELECTRIC THROTTLE CONTROL ACTUATOR (BANK 2)
Connector Type	RH08FB



Terminal No.	Color of Wire	Signal Name [Specification]
1	G	-
2	R	-
3	W	-
4	B	-
5	GR	-
6	V	-

Connector No.	F28
Connector Name	INFAKE VALVE TIMING CONTROL SOLENOID VALVE (BANK 1)
Connector Type	ED2FG-RS-LGY



Terminal No.	Color of Wire	Signal Name [Specification]
1	W	-
2	R	-

Connector No.	F29
Connector Name	INFAKE VALVE TIMING CONTROL SOLENOID VALVE (BANK 2)
Connector Type	ED2FG-RS-LGY



Terminal No.	Color of Wire	Signal Name [Specification]
1	G	-
2	R	-

Connector No.	F31
Connector Name	MASS AIR FLOW SENSOR (BANK 1)
Connector Type	RH08FB



Terminal No.	Color of Wire	Signal Name [Specification]
1	B	-
2	P	-
3	SB	-
4	LG	-
5	Y	-

Connector No.	F35
Connector Name	POWER STEERING PRESSURE SENSOR
Connector Type	RK03FB



Terminal No.	Color of Wire	Signal Name [Specification]
1	LG	-
2	Y	-
3	R	-

Connector No.	F38
Connector Name	ENGINE OIL TEMPERATURE SENSOR
Connector Type	ED2FGY-RS



Terminal No.	Color of Wire	Signal Name [Specification]
1	G	-
2	B	-

Connector No.	F42
Connector Name	MASS AIR FLOW SENSOR (BANK 2)
Connector Type	RH08FB



Terminal No.	Color of Wire	Signal Name [Specification]
3	BR	-
4	Y	-
5	GR	-

Connector No.	F46
Connector Name	VVEL CONTROL SHFT POSITION SENSOR (BANK 1)
Connector Type	RH08FB



Terminal No.	Color of Wire	Signal Name [Specification]
1	R	-
2	B	-
3	GR	-
4	G	-
5	W	-
6	Y	-

JCBWA1352GB

VVEL CONTROL MODULE

< ECU DIAGNOSIS INFORMATION >

[VQ37VHR]

ENGINE CONTROL SYSTEM

Connector No.	F47
Connector Name	VVEL CONTROL SHAFT POSITION SENSOR (BANK 2)
Connector Type	RK02FB



Terminal No.	Color of Wire	Signal Name [Specification]
1	L/G	-
2	L/Y	-
3	W	-
4	O/L	-
5	W/L	-
6	LG	-

Connector No.	F48
Connector Name	VVEL ACTUATOR MOTOR (BANK 1)
Connector Type	XQ2FB



Terminal No.	Color of Wire	Signal Name [Specification]
1	G	-
2	BR	-

Connector No.	F49
Connector Name	VVEL ACTUATOR MOTOR (BANK 2)
Connector Type	XQ2FB



Terminal No.	Color of Wire	Signal Name [Specification]
1	L/B	-
2	L/Y	-

Connector No.	F50
Connector Name	MANIFOLD ABSOLUTE PRESSURE (MAP) SENSOR
Connector Type	RK02FB



Terminal No.	Color of Wire	Signal Name [Specification]
1	L	-
2	O	-
3	W	-

Connector No.	F51
Connector Name	A/T ASSEMBLY
Connector Type	RK1UFG-D5Y

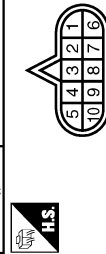

Terminal No.	Color of Wire	Signal Name [Specification]
3	L	-
8	P	-
9	GR	-

Connector No.	F53
Connector Name	HEATED OXYGEN SENSOR 2 (BANK 2)
Connector Type	AF204FB

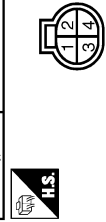

Terminal No.	Color of Wire	Signal Name [Specification]
1	B	-
2	LG	-
3	SB	-
4	O	-

Connector No.	F54
Connector Name	HEATED OXYGEN SENSOR 2 (BANK 1)
Connector Type	AF204FB

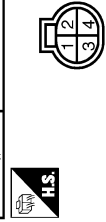

Terminal No.	Color of Wire	Signal Name [Specification]
1	B	-
2	R	-
3	P	-
4	W	-

Connector No.	F55
Connector Name	PARK / NEUTRAL POSITION SWITCH
Connector Type	RK02FB

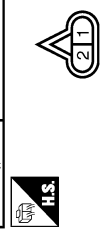

Terminal No.	Color of Wire	Signal Name [Specification]
1	BR	-
2	W	-

JCBWA1353GB

A
EC
C
D
E
F
G
H
I
J
K
L
M
N
O
P

VVEL CONTROL MODULE

< ECU DIAGNOSIS INFORMATION >

[VQ37VHR]

ENGINE CONTROL SYSTEM

Connector No.	F101
Connector Name	ECM
Connector Type	RH40FB-R28-L-LH-Z

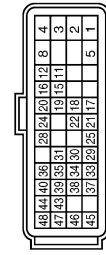

Terminal No.	Color of Wire	Signal Name [Specification]
1	W	AFH1/O2HF1
2	G	MOTOR1-B1
3	R	VMOT1-B1
4	BR	MOTOR2-B1
5	W	AFH2/O2HF2
8	B	GND
11	GR	IGN#4
12	L	IGN#3
15	V	IGN#5
16	G	IGN#2
17	P	O2HRI

Connector No.	F102
Connector Name	ECM
Connector Type	RH40FB-R28-L-LH-Z

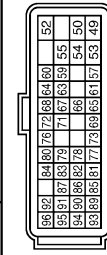

Terminal No.	Color of Wire	Signal Name [Specification]
49	GR	MOTOR2-B2
50	V	MOTOR1-B2
52	R	VMOT-B2
53	W	IGNSW
54	Y	ENG CAN-L1
55	LG	ENG CAN-H1
57	L	AF-1/O2SFI
59	O	PHASE#1
60	G	AVCC-PHS1-E-PHS1/PS
61	R	AF-
63	L	PHASE#2

18	W	CVTCH
19	SB	IGN#6
20	Y	IGN#1
21	GR	EVAP
22	P	FFP
24	P	SSOFF
25	O	MOTRLY-B1
26	BR	ABORT
28	G	CVTCH2
29	G	TPST-B1
30	Y	TPST-B1
31	R	TPST-B2
33	SB	O2HR2
34	B	TPSZ-B1
35	W	TPSZ-B2
36	O	GND-INTPRES/MVPRES
37	W	POS
38	O	INTPRES1
39	P	MVPRES
40	R	GND-TPS-B1
43	G	AVCC-TPS-B2
44	L	AVCC-TPS-B1
45	LG	AVCCZ/INTPRES/MVPRES
46	R	AVCCZ-POS
47	Y	GND-POS
48	B	GND-TPS-B2

84	Y	GND-OA2/TAT2
85	G	GND-CURSEN
86	P	GND-PHASE#1/PS

Connector No.	F103
Connector Name	WIRE TO WIRE
Connector Type	TK36PW-NS10

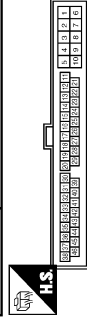

Terminal No.	Color of Wire	Signal Name [Specification]
3	W	
4	R	
5	B	
9	Y	
10	GR	
42	BR	
43	P	
44	L	

JCBWA1354GB

VVEL CONTROL MODULE

< ECU DIAGNOSIS INFORMATION >

[VQ37VHR]

ENGINE CONTROL SYSTEM

Connector No.	F120
Connector Name	WIRE TO WIRE
Connector Type	RH3BMB



Terminal No.	Color of Wire	Signal Name [Specification]
1	G	-
2	GR	-
3	BR	-
4	R	-
5	O	-
6	W	-
7	V	-

Connector No.	F121
Connector Name	FUEL INJECTOR No. 1
Connector Type	HS02FGY



Terminal No.	Color of Wire	Signal Name [Specification]
1	G	-
2	GR	-

Connector No.	F122
Connector Name	FUEL INJECTOR No. 2
Connector Type	HS02FGY



Terminal No.	Color of Wire	Signal Name [Specification]
1	G	-
2	BR	-

Connector No.	F123
Connector Name	FUEL INJECTOR No. 3
Connector Type	HS02FGY



Terminal No.	Color of Wire	Signal Name [Specification]
1	G	-
2	R	-

Connector No.	F124
Connector Name	FUEL INJECTOR No. 4
Connector Type	HS02FGY



Terminal No.	Color of Wire	Signal Name [Specification]
1	G	-
2	O	-

Connector No.	F125
Connector Name	FUEL INJECTOR No. 5
Connector Type	HS02FGY

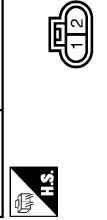

Terminal No.	Color of Wire	Signal Name [Specification]
1	G	-
2	W	-

Connector No.	F126
Connector Name	FUEL INJECTOR No. 6
Connector Type	HS02FGY

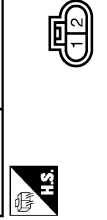

Terminal No.	Color of Wire	Signal Name [Specification]
1	G	-
2	V	-

Connector No.	F127
Connector Name	TGM (TRANSMISSION CONTROL MODULE)
Connector Type	SP10FG

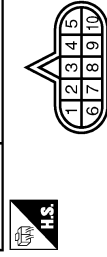

Terminal No.	Color of Wire	Signal Name [Specification]
3	R	CAN-H
8	BR	CAN-L
9	Y	STARTER RELY

A
EC
C
D
E
F
G
H
I
J
K
L
M
N
O
P

VVEL CONTROL MODULE

< ECU DIAGNOSIS INFORMATION >

[VQ37VHR]

ENGINE CONTROL SYSTEM

Connector No.	F201
Connector Name	WIRE TO WIRE
Connector Type	R32MIL-B



Terminal No.	Color of Wire	Signal Name [Specification]
1	W	-
2	SHIELD	-
3	W	-
4	SHIELD	-

Connector No.	F202
Connector Name	KNOCK SENSOR (BANK 2)
Connector Type	ED2EG-RS-LGY



Terminal No.	Color of Wire	Signal Name [Specification]
1	W	-
2	SHIELD	-

Connector No.	F203
Connector Name	KNOCK SENSOR (BANK 1)
Connector Type	ED2EG-RS-LGY



Terminal No.	Color of Wire	Signal Name [Specification]
1	W	-
2	SHIELD	-

Connector No.	M1
Connector Name	FUSE BLOCK (J/B)
Connector Type	NSURFW-M2



Terminal No.	Color of Wire	Signal Name [Specification]
1A	V	-
2A	G	-

Connector No.	M2
Connector Name	FUSE BLOCK (J/B)
Connector Type	NSURFW-CS



Terminal No.	Color of Wire	Signal Name [Specification]
3B	P	-
6B	Y	-

Connector No.	M6
Connector Name	WIRE TO WIRE
Connector Type	TH80MW-CS (F-TM4)

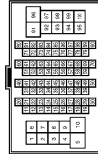

Terminal No.	Color of Wire	Signal Name [Specification]
7	R	-
31	P	-
32	L	-
43	W	-
44	L	-
45	O	-
66	GR	- [With A/T]
80	P	- [With M/T]
81	GR	-
82	R	-

Connector No.	M7
Connector Name	WIRE TO WIRE
Connector Type	TH80MW-CS (F-TM4)

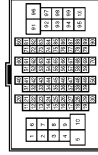

Terminal No.	Color of Wire	Signal Name [Specification]
1	O	-
2	LG	-
20	BR	-
21	G	-
22	R	-
60	W	-
66	Y	-
87	P	-
88	L	-
89	P	-
90	L	-

JCBWA1356GB

VVEL CONTROL MODULE

< ECU DIAGNOSIS INFORMATION >

[VQ37VHR]

ENGINE CONTROL SYSTEM

Connector No.	M17
Connector Name	WIRE TO WIRE
Connector Type	TKG2FW



Terminal No.	Color of Wire	Signal Name [Specification]
1	L	-
2	P	-

Connector No.	M18
Connector Name	WIRE TO WIRE
Connector Type	TKG2MW



Terminal No.	Color of Wire	Signal Name [Specification]
1	L	-
2	P	-

Connector No.	M24
Connector Name	DATA LINK CONNECTOR
Connector Type	BD16FW

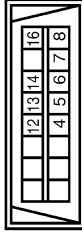

Terminal No.	Color of Wire	Signal Name [Specification]
4	B	-
5	BR	-
6	L	-
7	V	-
8	G	-
14	P	-
16	R	-

Connector No.	M38
Connector Name	COMBINATION SWITCH (SPIRAL CABLE)
Connector Type	TKG8FGY-TV

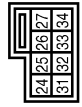

Terminal No.	Color of Wire	Signal Name [Specification]
25	SB	-
32	Y	-

Connector No.	M53
Connector Name	COMBINATION METER
Connector Type	SAG4FW

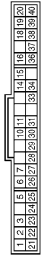

Terminal No.	Color of Wire	Signal Name [Specification]
2	LG	COMMUNICATION SIGNAL (METER->AMP)
3	GR	COMMUNICATION SIGNAL (AMP->METER)
24	BR	COMMUNICATION SIGNAL (LCD->AMP)
25	Y	COMMUNICATION SIGNAL (AMP->LCD)

Connector No.	M56
Connector Name	UNIFIED METER AND A/C AMP.
Connector Type	TH40FW-NH



Terminal No.	Color of Wire	Signal Name [Specification]
7	GR	COMMUNICATION SIGNAL (AMP->METER)
14	BR	COMMUNICATION SIGNAL (LCD->AMP)
27	LG	COMMUNICATION SIGNAL (METER->AMP)
34	Y	COMMUNICATION SIGNAL (AMP->LCD)

Connector No.	M57
Connector Name	UNIFIED METER AND A/C AMP.
Connector Type	TH42FW-NH



Terminal No.	Color of Wire	Signal Name [Specification]
53	W	IGNITION POWER SUPPLY
54	Y	BATTERY POWER SUPPLY
55	B	GROUND
56	L	CAN-H
58	Y	FUEL LEVEL SENSOR SIGNAL GROUND
71	GR	GROUND
72	P	CAN-L

A
EC
C
D
E
F
G
H
I
J
K
L
M
N
O
P

VVEL CONTROL MODULE

< ECU DIAGNOSIS INFORMATION >

[VQ37VHR]

ENGINE CONTROL SYSTEM

Connector No.	M107
Connector Name	ECM
Connector Type	RH24FGY-R26-R-LH-Z



Terminal No.	Color of Wire	Signal Name [Specification]
97	R	APSI
98	P	APSZ
99	L	AVCC1-APSI
100	W	GND-APSI
101	SB	ASCDSW
102	G	FTPRS
103	G	AVCC2-APSZ
104	GR	GND-APSZ
105	L	PDPRESS
106	W	TF
107	BR	AVCC-PDPRES

Connector No.	M303
Connector Name	COMBINATION SWITCH (SPIRAL CABLE)
Connector Type	TK08FGY



Terminal No.	Color of Wire	Signal Name [Specification]
13	-	-
16	-	-

Terminal No.	Color of Wire	Signal Name [Specification]
108	Y	GND-ASCDSW
109	G	NEUT-H
110	R	TACHO
112	R	GND-PDPRES
113	P	VELCAN-LI
114	L	VELCAN-HI
117	V	KLINE
121	LG	GDCV
122	P	BRAKE
123	B	GND
124	B	GND
125	R	VBR
126	BR	BRCSW
127	B	GND
128	B	GND

Connector No.	M108
Connector Name	POWER STEERING CONTROL UNIT
Connector Type	TH12FW-NH

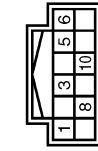

Terminal No.	Color of Wire	Signal Name [Specification]
10	R	TACHO

Connector No.	M116
Connector Name	WIRE TO WIRE
Connector Type	TK38MW-N10



Terminal No.	Color of Wire	Signal Name [Specification]
3	O	-
4	R	-
5	B	-
9	R	-
10	R	-
42	G	-
43	P	-
44	L	-

ENGINE CONTROL SYSTEM SYMPTOMS

< SYMPTOM DIAGNOSIS >

[VQ37VHR]

SYMPTOM DIAGNOSIS

ENGINE CONTROL SYSTEM SYMPTOMS

Symptom Table

INFOID:000000005152113

SYSTEM — BASIC ENGINE CONTROL SYSTEM

		SYMPTOM												Reference page	
		HARD/NO START/RESTART (EXCP. HA)	ENGINE STALL	HESITATION/SURGING/FLAT SPOT	SPARK KNOCK/DETONATION	LACK OF POWER/POOR ACCELERATION	HIGH IDLE/LOW IDLE	ROUGH IDLE/HUNTING	IDLING VIBRATION	SLOW/NO RETURN TO IDLE	OVERHEATS/WATER TEMPERATURE HIGH	EXCESSIVE FUEL CONSUMPTION	EXCESSIVE OIL CONSUMPTION		BATTERY DEAD (UNDER CHARGE)
Warranty symptom code		AA	AB	AC	AD	AE	AF	AG	AH	AJ	AK	AL	AM	HA	
Fuel	Fuel pump circuit	1	1	2	3	2		2	2			3		2	EC-495
	Fuel pressure regulator system	3	3	4	4	4	4	4	4	4		4			EC-607
	Fuel injector circuit	1	1	2	3	2		2	2			2			EC-492
	Evaporative emission system	3	3	4	4	4	4	4	4	4	4	4			EC-80
Air	Positive crankcase ventilation system	3	3	4	4	4	4	4	4	4	4	4	1		EC-514
	Incorrect idle speed adjustment						1	1	1	1		1			EC-13
	Electric throttle control actuator	1	1	2	3	3	2	2	2	2		2		2	EC-398 , EC-405
Ignition	Incorrect ignition timing adjustment	3	3	1	1	1		1	1			1			EC-13
	Ignition circuit	1	1	2	2	2		2	2			2			EC-503
Main power supply and ground circuit		2	2	3	3	3		3	3		2	3			EC-140
Mass air flow sensor circuit		1			2										EC-165 , EC-172
Engine coolant temperature sensor circuit					3										
Air fuel ratio (A/F) sensor 1 circuit			1	2	3	2		2	2			2			EC-201 , EC-205 , EC-208 , EC-211 , EC-476
Throttle position sensor circuit							2			2					EC-190 , EC-256 , EC-394 , EC-396 , EC-407
Accelerator pedal position sensor circuit				3	2	1									EC-463 , EC-467 , EC-471
Knock sensor circuit				2								3			EC-266

A
EC
C
D
E
F
G
H
I
J
K
L
M
N
O
P

ENGINE CONTROL SYSTEM SYMPTOMS

< SYMPTOM DIAGNOSIS >

[VQ37VHR]

	SYMPTOM													Reference page
	HARD/NO START/RESTART (EXCP. HA)	ENGINE STALL	HESITATION/SURGING/FLAT SPOT	SPARK KNOCK/DETONATION	LACK OF POWER/POOR ACCELERATION	HIGH IDLE/LOW IDLE	ROUGH IDLE/HUNTING	IDLING VIBRATION	SLOW/NO RETURN TO IDLE	OVERHEATS/WATER TEMPERATURE HIGH	EXCESSIVE FUEL CONSUMPTION	EXCESSIVE OIL CONSUMPTION	BATTERY DEAD (UNDER CHARGE)	
Warranty symptom code	AA	AB	AC	AD	AE	AF	AG	AH	AJ	AK	AL	AM	HA	
Engine oil temperature sensor			4		1						3			EC-250 , EC-253
Crankshaft position sensor (POS) circuit	2	2												EC-269
Camshaft position sensor (PHASE) circuit	3	2												EC-273
Vehicle speed signal circuit		2	3		3						3			EC-342
Power steering pressure sensor circuit		2					3	3						EC-351
ECM	2	2	3	3	3	3	3	3	3	3	3			EC-359 , EC-361
Intake valve timing control solenoid valve circuit		3	2		1	3	2	2	3		3			EC-162
Manifold absolute pressure (MAP) sensor											3			EC-178
Brake booster pressure sensor											3			EC-354
VVEL control module	3		4	4	3									EC-453 , EC-455
VVEL actuator motor	3		4	4	3									EC-380
VVEL actuator motor relay	3		4	4	3									EC-384
VVEL actuator shaft position sensor	3		4	4	3									EC-376
PNP signal circuit			3		3		3	3			3			EC-367
Refrigerant pressure sensor circuit		2				3			3		4			EC-516
Electrical load signal circuit							3							EC-490
Air conditioner circuit	2	2	3	3	3	3	3	3	3		3		2	HAC-4
ABS actuator and electric unit (control unit)			4											BRC-5

1 - 6: The numbers refer to the order of inspection.

(continued on next page)

SYSTEM — ENGINE MECHANICAL & OTHER

ENGINE CONTROL SYSTEM SYMPTOMS

< SYMPTOM DIAGNOSIS >

[VQ37VHR]

		SYMPTOM												Reference page			
		HARD/NO START/RESTART (EXCP. HA)	ENGINE STALL	HESITATION/SURGING/FLAT SPOT	SPARK KNOCK/DETONATION	LACK OF POWER/POOR ACCELERATION	HIGH IDLE/LOW IDLE	ROUGH IDLE/HUNTING	IDLING VIBRATION	SLOW/NO RETURN TO IDLE	OVERHEATS/WATER TEMPERATURE HIGH	EXCESSIVE FUEL CONSUMPTION	EXCESSIVE OIL CONSUMPTION		BATTERY DEAD (UNDER CHARGE)		
Warranty symptom code		AA	AB	AC	AD	AE	AF	AG	AH	AJ	AK	AL	AM	HA			
Fuel	Fuel tank	5	5											FL-12			
	Fuel piping			5	5	5		5	5		5			FL-4			
	Vapor lock														—		
	Valve deposit														—		
	Poor fuel (Heavy weight gasoline, Low octane)	5			5	5	5		5	5			5		—		
Air	Air duct		5											EM-28			
	Air cleaner													EM-28			
	Air leakage from air duct (Mass air flow sensor — electric throttle control actuator)	5		5	5	5		5	5				5		EM-28		
	Electric throttle control actuator				5		5			5					EM-29		
	Air leakage from intake manifold/Collector/Gasket														EM-33		
Cranking	Battery	1	1	1		1		1	1					1	PG-100		
	Generator circuit														CHG-23 , CHG-24		
	Starter circuit	3										1		STR-5 , STR-6			
	Signal plate	6												EM-121			
	PNP signal circuit	4												TM-9 , TM-161			
Engine	Cylinder head	5	5	5	5	5		5	5			5	3	4	EM-107		
	Cylinder head gasket																4
	Cylinder block																
	Piston												4				
	Piston ring	6	6	6	6	6		6	6			6		6	EM-121		
	Connecting rod																
	Bearing																
	Crankshaft																

A
EC
C
D
E
F
G
H
I
J
K
L
M
N
O
P

ENGINE CONTROL SYSTEM SYMPTOMS

< SYMPTOM DIAGNOSIS >

[VQ37VHR]

		SYMPTOM												Reference page	
		HARD/NO START/RESTART (EXCP. HA)	ENGINE STALL	HESITATION/SURGING/FLAT SPOT	SPARK KNOCK/DETONATION	LACK OF POWER/POOR ACCELERATION	HIGH IDLE/LOW IDLE	ROUGH IDLE/HUNTING	IDLING VIBRATION	SLOW/NO RETURN TO IDLE	OVERHEATS/WATER TEMPERATURE HIGH	EXCESSIVE FUEL CONSUMPTION	EXCESSIVE OIL CONSUMPTION		BATTERY DEAD (UNDER CHARGE)
Warranty symptom code		AA	AB	AC	AD	AE	AF	AG	AH	AJ	AK	AL	AM	HA	
Valve mechanism	Timing chain														EM-64
	Camshaft														EM-94
	Intake valve timing control	5	5	5	5	5		5	5			5			EM-64
	Intake valve												3		EM-107
	Exhaust valve														
Exhaust	Exhaust manifold/Tube/Muffler/Gasket	5	5	5	5	5		5	5			5			EX-4, EX-6
	Three way catalyst														
Lubrication	Oil pan/Oil strainer/Oil pump/Oil filter/Oil gallery/Oil cooler	5	5	5	5	5		5	5			5			LU-9, LU-10, LU-11
	Oil level (Low)/Filthy oil														LU-6
Cooling	Radiator/Hose/Radiator filler cap														CO-10, CO-10
	Thermostat									5					CO-20
	Water pump	5	5	5	5	5		5	5		4	5			CO-19
	Water gallery														CO-23
	Cooling fan														CO-16
	Coolant level (Low)/Contaminated coolant									5					CO-7
IVIS (INFINITI Vehicle Immobilizer System — NATS)		1	1												SEC-5

1 - 6: The numbers refer to the order of inspection.

NORMAL OPERATING CONDITION

< SYMPTOM DIAGNOSIS >

[VQ37VHR]

NORMAL OPERATING CONDITION

Description

INFOID:000000005152114

FUEL CUT CONTROL (AT NO LOAD AND HIGH ENGINE SPEED)

If the engine speed is above 1,400 rpm under no load (for example, the selector lever position is neutral and engine speed is over 1,400 rpm) fuel will be cut off after some time. The exact time when the fuel is cut off varies based on engine speed. However, if the engine speed is above 4,000 rpm, fuel will be cut off in a few seconds. Fuel cut will be operated until the engine speed reaches 1,000 rpm, then fuel cut will be cancelled.

NOTE:

This function is different from deceleration control listed under Multiport Fuel Injection (MFI) System, [EC-34. "System Description"](#).

TORQUE CUT CONTROL (AT HIGH ENGINE OIL TEMPERATURE)

ECM receives engine oil temperature signal from engine oil temperature sensor.

To avoid VVEL performance, ECM performs the engine torque cut control at high engine oil temperature.

If engine oil temperature is too high, engine oil viscosity will change. As a result, engine oil pressure is decreased. This control is to control the VVEL operating angle by operating the VVEL actuator sub assembly. If this control is operated, engine performance will decrease, then maximum engine speed is reduced a little, for example.

NOTE:

If the engine oil temperature sensor is deteriorated, its characteristic will change.

In this case, the operating temperature for engine torque cut control might be decrease.

Perform Component Inspection of the engine oil temperature sensor to check for the deterioration.

Refer to [EC-252. "Component Inspection"](#).

A
EC
C
D
E
F
G
H
I
J
K
L
M
N
O
P

PRECAUTIONS

< PRECAUTION >

[VQ37VHR]

PRECAUTION

PRECAUTIONS

Precaution for Supplemental Restraint System (SRS) "AIR BAG" and "SEAT BELT PRE-TENSIONER"

INFOID:000000005152115

The Supplemental Restraint System such as "AIR BAG" and "SEAT BELT PRE-TENSIONER", used along with a front seat belt, helps to reduce the risk or severity of injury to the driver and front passenger for certain types of collision. This system includes seat belt switch inputs and dual stage front air bag modules. The SRS system uses the seat belt switches to determine the front air bag deployment, and may only deploy one front air bag, depending on the severity of a collision and whether the front occupants are belted or unbelted. Information necessary to service the system safely is included in the "SRS AIR BAG" and "SEAT BELT" of this Service Manual.

WARNING:

- To avoid rendering the SRS inoperative, which could increase the risk of personal injury or death in the event of a collision that would result in air bag inflation, all maintenance must be performed by an authorized NISSAN/INFINITI dealer.
- Improper maintenance, including incorrect removal and installation of the SRS, can lead to personal injury caused by unintentional activation of the system. For removal of Spiral Cable and Air Bag Module, see the "SRS AIR BAG".
- Do not use electrical test equipment on any circuit related to the SRS unless instructed to in this Service Manual. SRS wiring harnesses can be identified by yellow and/or orange harnesses or harness connectors.

PRECAUTIONS WHEN USING POWER TOOLS (AIR OR ELECTRIC) AND HAMMERS

WARNING:

- When working near the Air Bag Diagnosis Sensor Unit or other Air Bag System sensors with the ignition ON or engine running, DO NOT use air or electric power tools or strike near the sensor(s) with a hammer. Heavy vibration could activate the sensor(s) and deploy the air bag(s), possibly causing serious injury.
- When using air or electric power tools or hammers, always switch the ignition OFF, disconnect the battery, and wait at least 3 minutes before performing any service.

Precaution for Procedure without Cowl Top Cover

INFOID:000000005184458

When performing the procedure after removing cowl top cover, cover the lower end of windshield with urethane, etc.

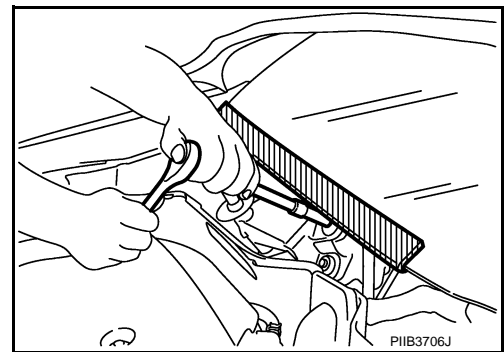

Precautions For Xenon Headlamp Service

INFOID:000000005184459

WARNING:

Comply with the following warnings to prevent any serious accident.

- Disconnect the battery cable (negative terminal) or the power supply fuse before installing, removing, or touching the xenon headlamp (bulb included). The xenon headlamp contains high-voltage generated parts.
- Never work with wet hands.
- Check the xenon headlamp ON-OFF status after assembling it to the vehicle. Never turn the xenon headlamp ON in other conditions. Connect the power supply to the vehicle-side connector. (Turning it ON outside the lamp case may cause fire or visual impairments.)
- Never touch the bulb glass immediately after turning it OFF. It is extremely hot.

PRECAUTIONS

< PRECAUTION >

[VQ37VHR]

CAUTION:

Comply with the following cautions to prevent any error and malfunction.

- Install the xenon bulb securely. (Insufficient bulb socket installation may melt the bulb, the connector, the housing, etc. by high-voltage leakage or corona discharge.)
- Never perform HID circuit inspection with a tester.
- Never touch the xenon bulb glass with hands. Never put oil and grease on it.
- Dispose of the used xenon bulb after packing it in thick vinyl without breaking it.
- Never wipe out dirt and contamination with organic solvent (thinner, gasoline, etc.).

On Board Diagnostic (OBD) System of Engine and A/T

INFOID:000000005152118

The ECM has an on board diagnostic system. It will illuminate the malfunction indicator lamp (MIL) to warn the driver of a malfunction causing emission deterioration.

CAUTION:

- Always turn the ignition switch OFF and disconnect the negative battery cable before any repair or inspection work. The open/short circuit of related switches, sensors, solenoid valves, etc. will cause the MIL to illuminate.
- Always connect and lock the connectors securely after work. A loose (unlocked) connector will cause the MIL to illuminate due to the open circuit. (Be sure the connector is free from water, grease, dirt, bent terminals, etc.)
- Certain systems and components, especially those related to OBD, may use a new style slide-locking type harness connector. For description and how to disconnect, refer to [PG-89, "Description"](#).
- Always route and secure the harnesses properly after work. The interference of the harness with a bracket, etc. may cause the MIL to illuminate due to the short circuit.
- Always connect rubber tubes properly after work. A misconnected or disconnected rubber tube may cause the MIL to illuminate due to the malfunction of the EVAP system or fuel injection system, etc.
- Always erase the unnecessary malfunction information (repairs completed) from the ECM and TCM (Transmission control module) before returning the vehicle to the customer.

General Precautions

INFOID:000000005152119

- Always use a 12 volt battery as power source.
- Never attempt to disconnect battery cables while engine is running.
- Before connecting or disconnecting the ECM harness connector, turn ignition switch OFF and disconnect negative battery cable. Failure to do so may damage the ECM because battery voltage is applied to ECM even if ignition switch is turned OFF.
- Before removing parts, turn ignition switch OFF and then disconnect negative battery cable.

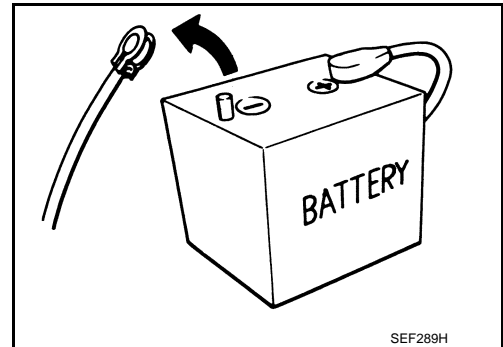

- Never disassemble ECM.
- If a battery cable is disconnected, the memory will return to the ECM value.
The ECM will now start to self-control at its initial value. Thus, engine operation can vary slightly in this case. However, this is not an indication of a malfunction. Never replace parts because of a slight variation.
- If the battery is disconnected, the following emission-related diagnostic information will be cleared within 24 hours.
 - Diagnostic trouble codes
 - 1st trip diagnostic trouble codes
 - Freeze frame data
 - 1st trip freeze frame data
 - System readiness test (SRT) codes
 - Test values

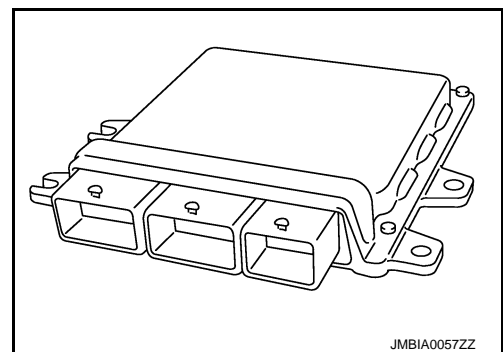

PRECAUTIONS

[VQ37VHR]

< PRECAUTION >

- When connecting ECM harness connector (A), fasten (B) it securely with a lever as far as it will go as shown in the figure.
- 1 : ECM
- C : Loosen

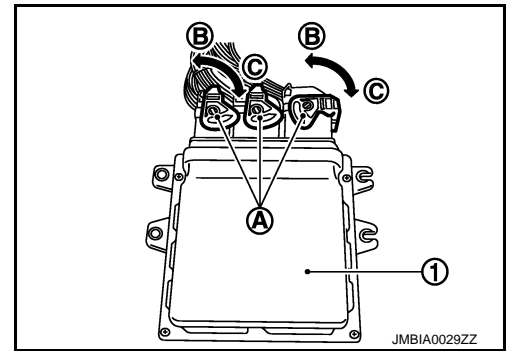

- When connecting or disconnecting pin connectors into or from ECM, never damage pin terminals (bends or break). Make sure that there are not any bends or breaks on ECM pin terminal, when connecting pin connectors.
- Securely connect ECM harness connectors. A poor connection can cause an extremely high (surge) voltage to develop in coil and condenser, thus resulting in damage to ICs.
- Keep engine control system harness at least 10 cm (4 in) away from adjacent harness, to prevent engine control system malfunctions due to receiving external noise, degraded operation of ICs, etc.
- Keep engine control system parts and harness dry.
- Before replacing ECM, perform ECM Terminals and Reference Value inspection and make sure ECM functions properly. Refer to [EC-518, "Reference Value"](#).
- Handle mass air flow sensor carefully to avoid damage.
- Never clean mass air flow sensor with any type of detergent.
- Never disassemble electric throttle control actuator.
- Even a slight leak in the air intake system can cause serious incidents.
- Never shock or jar the camshaft position sensor (PHASE), crankshaft position sensor (POS).

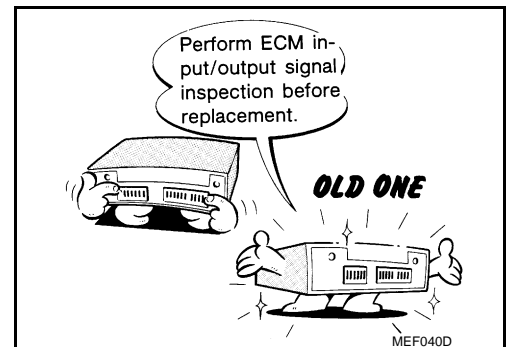
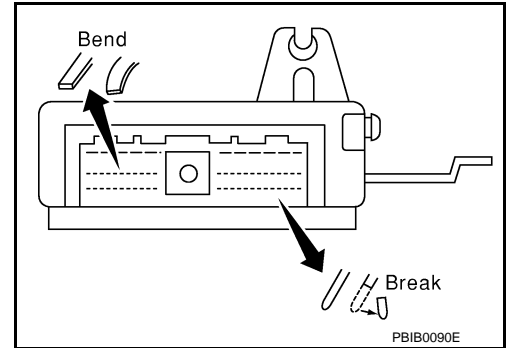

- After performing each TROUBLE DIAGNOSIS, perform DTC Confirmation Procedure or Component Function Check. The DTC should not be displayed in the DTC Confirmation Procedure if the repair is completed. The Component Function Check should be a good result if the repair is completed.

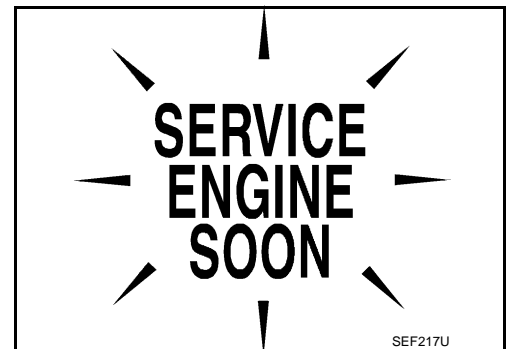

PRECAUTIONS

[VQ37VHR]

< PRECAUTION >

- When measuring ECM signals with a circuit tester, never allow the two tester probes to contact. Accidental contact of probes will cause a short circuit and damage the ECM power transistor.

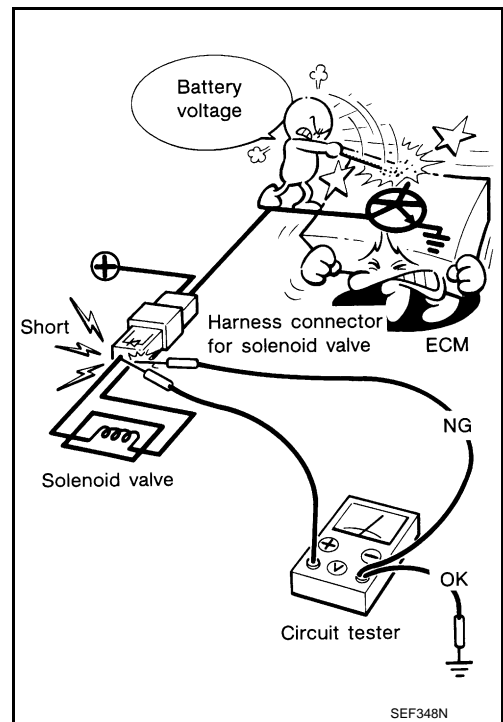

- B1 indicates bank 1, B2 indicates bank 2 as shown in the figure.
- Never operate fuel pump when there is no fuel in lines.
- Tighten fuel hose clamps to the specified torque.

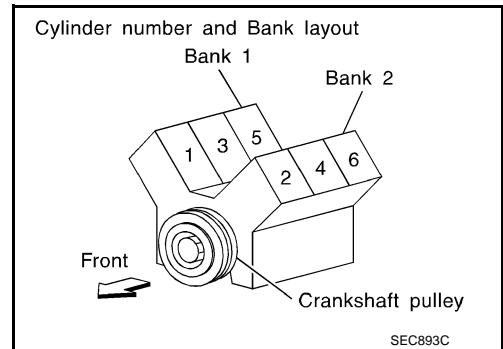

- Never depress accelerator pedal when starting.
- Immediately after starting, never rev up engine unnecessarily.
- Never rev up engine just prior to shutdown.

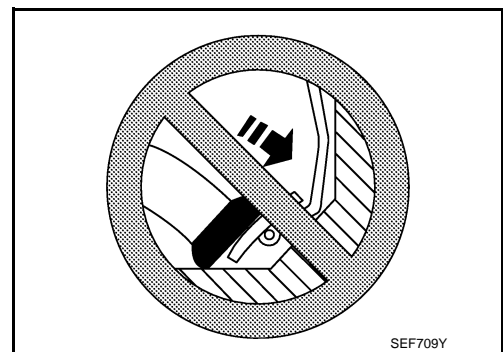

A
EC
C
D
E
F
G
H
I
J
K
L
M
N
O
P

PRECAUTIONS

[VQ37VHR]

< PRECAUTION >

- When installing C.B. ham radio or a mobile phone, be sure to observe the following as it may adversely affect electronic control systems depending on installation location.
- Keep the antenna as far as possible from the electronic control units.
- Keep the antenna feeder line more than 20 cm (8 in) away from the harness of electronic controls. Never let them run parallel for a long distance.
- Adjust the antenna and feeder line so that the standing-wave ratio can be kept smaller.
- Be sure to ground the radio to vehicle body.

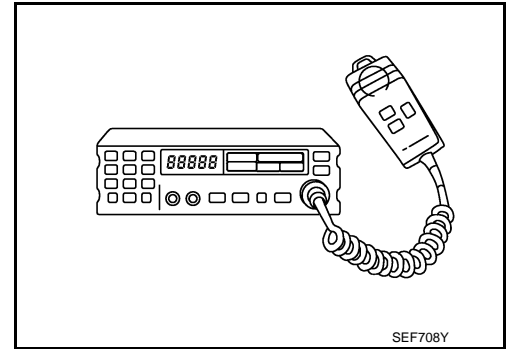

PREPARATION

< PREPARATION >

[VQ37VHR]

PREPARATION

PREPARATION

Special Service Tools

INFOID:000000005152120

A

EC

NOTE:

The actual shapes of Kent-Moore tools may differ from those of special service tools illustrated here.

C

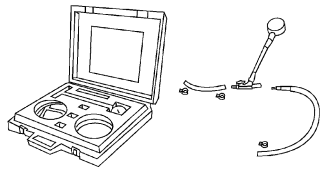
Tool number (Kent-Moore No.) Tool name	Description
(J-44321) Fuel pressure gauge kit  <p style="text-align: center;">LEC642</p>	Checks fuel pressure

D

E

F

Commercial Service Tools

INFOID:000000005152121

G

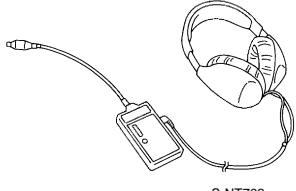
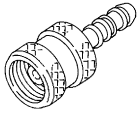
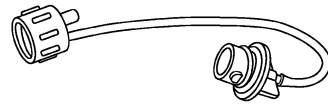
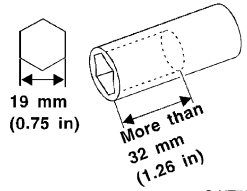
Tool name (Kent-Moore No.)	Description
Leak detector i.e.: (J-41416)  <p style="text-align: center;">S-NT703</p>	Locates the EVAP leak
EVAP service port adapter i.e.: (J-41413-OBD)  <p style="text-align: center;">S-NT704</p>	Applies positive pressure through EVAP service port
Fuel filler cap adapter i.e.: (MLR-8382)  <p style="text-align: center;">S-NT815</p>	Checks fuel tank vacuum relief valve opening pressure
Socket wrench  <p style="text-align: center;">S-NT705</p>	Removes and installs engine coolant temperature sensor

H

I

J

K

L

M

N



O

P

PREPARATION

< PREPARATION >

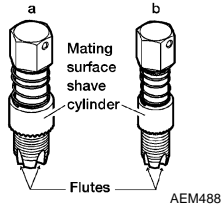
[VQ37VHR]

Tool name (Kent-Moore No.)	Description
<p>Oxygen sensor thread cleaner i.e.: (J-43897-18) (J-43897-12)</p> 	<p>Reconditions the exhaust system threads before installing a new oxygen sensor. Use with anti-seize lubricant shown below. a: 18 mm diameter with pitch 1.5 mm for Zirconia Oxygen Sensor b: 12 mm diameter with pitch 1.25 mm for Titanium Oxygen Sensor</p>
<p>Anti-seize lubricant i.e.: (Permatex™ 133AR or equivalent meeting MIL specification MIL-A-907)</p> 	<p>Lubricates oxygen sensor thread cleaning tool when reconditioning exhaust system threads.</p>

PERIODIC MAINTENANCE

FUEL PRESSURE

Inspection

INFOID:000000005152122

FUEL PRESSURE RELEASE

④ With CONSULT-III

1. Turn ignition switch ON.
2. Perform "FUEL PRESSURE RELEASE" in "WORK SUPPORT" mode with CONSULT-III.
3. Start engine.
4. After engine stalls, crank it two or three times to release all fuel pressure.
5. Turn ignition switch OFF.

⊗ Without CONSULT-III

1. Remove fuel pump fuse (1) located in IPDM E/R (2).
2. Start engine.
3. After engine stalls, crank it two or three times to release all fuel pressure.
4. Turn ignition switch OFF.
5. Reinstall fuel pump fuse after servicing fuel system.

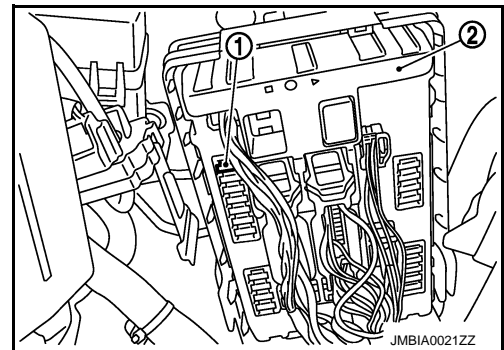

FUEL PRESSURE CHECK

CAUTION:

Before disconnecting fuel line, release fuel pressure from fuel line to eliminate danger.

NOTE:

- Prepare pans or saucers under the disconnected fuel line because the fuel may spill out. The fuel pressure cannot be completely released because HV36 models do not have fuel return system.
- Use Fuel Pressure Gauge Kit (J-44321) to check fuel pressure.

1. Release fuel pressure to zero.
2. Install the inline fuel quick disconnected fitting (A) between fuel damper (1) and injector tube.
3. Connect the fuel pressure test gauge (quick connector adapter hose) (B) to the inline fuel quick disconnected fitting.
4. Turn ignition switch ON and check for fuel leakage.
5. Start engine and check for fuel leakage.
6. Read the indication of fuel pressure gauge.

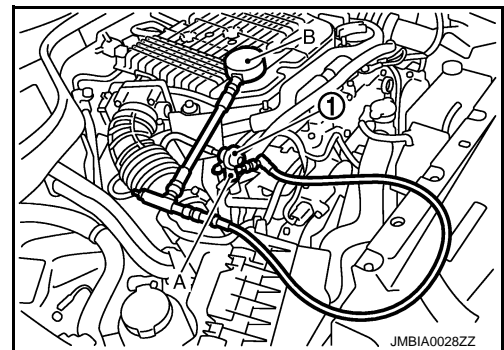

At idling : Approximately 350 kPa (3.57 kg/cm², 51 psi)

7. If result is unsatisfactory, check fuel hoses and fuel tubes for clogging.
If OK, Replace "fuel filter and fuel pump assembly".
If NG, Repair or replace.

EVAP LEAK CHECK

< PERIODIC MAINTENANCE >

[VQ37VHR]

EVAP LEAK CHECK

Inspection

INFOID:000000005152123

CAUTION:

- Do not use compressed air or a high pressure pump.
- Do not exceed 4.12 kPa (0.042 kg/cm², 0.6 psi) of pressure in EVAP system.

NOTE:

- Do not start engine.
- Improper installation of EVAP service port adapter to the EVAP service port may cause a leak.

Ⓟ WITH CONSULT-III

1. To locate the EVAP leak, install EVAP service port adapter and pressure pump to EVAP service port.
2. Turn ignition switch ON.
3. Select the "EVAP SYSTEM CLOSE" of "WORK SUPPORT" mode with CONSULT-III.
4. Touch "START". A bar graph (Pressure indicating display) will appear on the screen.
5. Apply positive pressure to the EVAP system until the pressure indicator reaches the middle of the bar graph.
6. Remove EVAP service port adapter and hose with pressure pump.
7. Locate the leak using a leak detector. Refer to [EC-80, "System Diagram"](#).

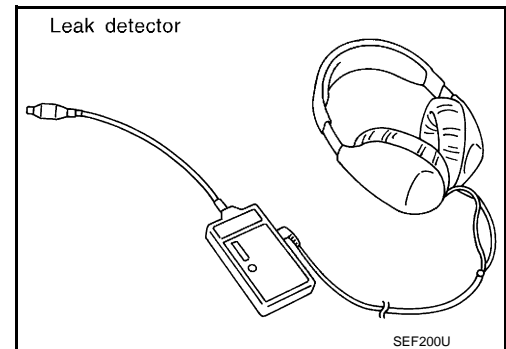
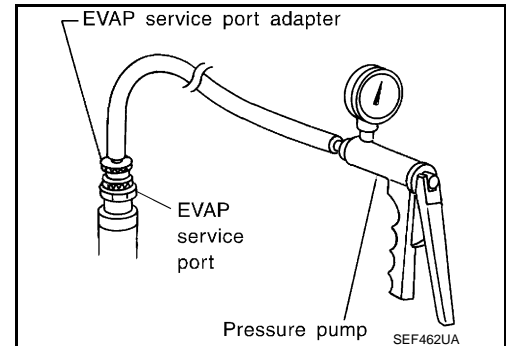

ⓧ WITHOUT CONSULT-III

1. To locate the EVAP leak, install EVAP service port adapter and pressure pump to EVAP service port.
2. Apply battery voltage between the terminals of EVAP canister vent control valve to make a closed EVAP system.
3. To locate the leak, deliver positive pressure to the EVAP system until pressure gauge points reach 1.38 to 2.76 kPa (0.014 to 0.028 kg/cm², 0.2 to 0.4 psi).
4. Remove EVAP service port adapter and hose with pressure pump.

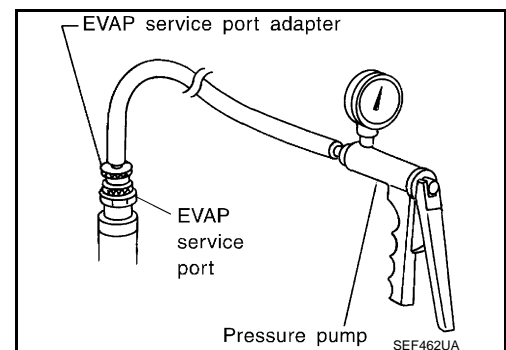

EVAP LEAK CHECK

< PERIODIC MAINTENANCE >

[VQ37VHR]

5. Locate the leak using a leak detector. Refer to [EC-80. "System Diagram"](#).

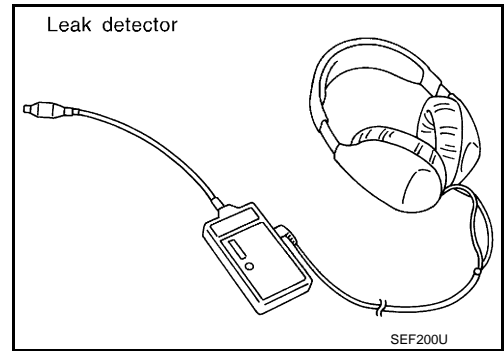

A
EC
C
D
E
F
G
H
I
J
K
L
M
N
O
P

EVAP CANISTER

< REMOVAL AND INSTALLATION >

[VQ37VHR]

REMOVAL AND INSTALLATION

EVAP CANISTER

Exploded View

INFOID:000000005152124

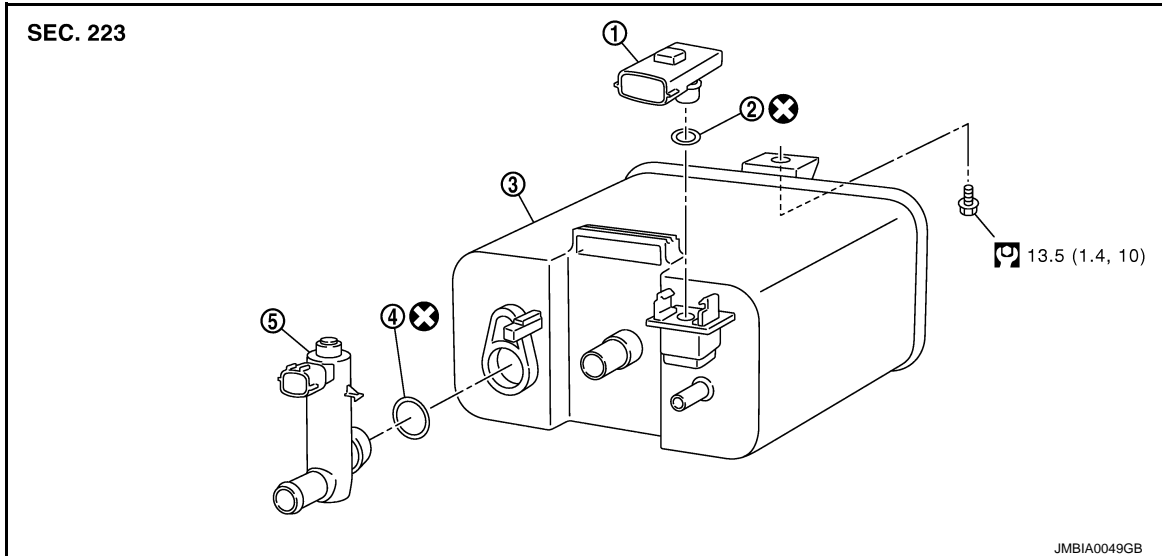

1. EVAP canister system pressure sensor
2. O-ring
3. EVAP canister
4. O-ring
5. EVAP canister vent control valve
- Refer to [GI-3. "Contents"](#) for symbols not described on the above.

Removal and Installation

INFOID:000000005152125

REMOVAL

1. Lift up the vehicle.
2. Remove EVAP canister fixing bolt.
3. Remove EVAP canister.

NOTE:

The EVAP canister vent control valve and EVAP canister system pressure sensor can be removed without removing the EVAP canister.

INSTALLATION

Install in the reverse order of removal.

NOTE:

Tighten EVAP canister fixing bolt to the specified torque.

DISASSEMBLY

1. Turn EVAP canister vent control valve counterclockwise.

A : Lock

B : Unlock

2. Remove the EVAP canister vent control valve.

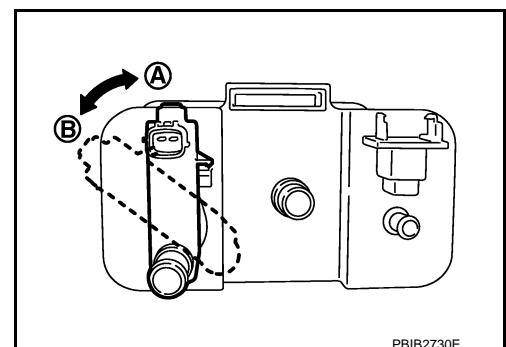

EVAP CANISTER

[VQ37VHR]

< REMOVAL AND INSTALLATION >

ASSEMBLY

Assemble in the reverse order of disassembly.

CAUTION:

Always replace O-ring with a new one.

Inspection

INFOID:000000005152126

Check EVAP canister as follows:

1. Block port (B).
2. Blow air into port (A) and check that it flows freely out of port (C).
3. Release blocked port (B).
4. Apply vacuum pressure to port (B) and check that vacuum pressure exists at the ports (A) and (C).
5. Block port (A) and (B).
6. Apply pressure to port (C) and check that there is no leakage.

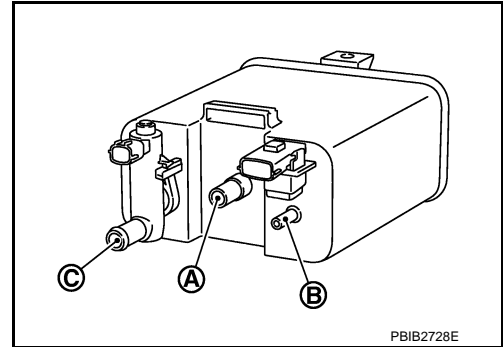

A

EC

C

D

E

F

G

H

I

J

K

L

M

N

O

P

SERVICE DATA AND SPECIFICATIONS (SDS)

< SERVICE DATA AND SPECIFICATIONS (SDS)

[VQ37VHR]

SERVICE DATA AND SPECIFICATIONS (SDS)

SERVICE DATA AND SPECIFICATIONS (SDS)

Idle Speed

INFOID:000000005152127

Transmission	Condition	Specification
A/T	No load* (in P or N position)	650 ± 50 rpm
M/T	No load* (in Neutral position)	650 ± 50 rpm

*: Under the following conditions

- A/C switch: OFF
- Electric load: OFF (Lights, heater fan & rear window defogger)
- Steering wheel: Kept in straight-ahead position

Ignition Timing

INFOID:000000005152128

Transmission	Condition	Specification
A/T	No load* (in P or N position)	10 ± 5° BTDC
M/T	No load* (in Neutral position)	10 ± 5° BTDC

*: Under the following conditions

- A/C switch: OFF
- Electric load: OFF (Lights, heater fan & rear window defogger)
- Steering wheel: Kept in straight-ahead position

Calculated Load Value

INFOID:000000005152129

Condition	Specification (Using CONSULT-III or GST)
At idle	5 – 35 %
At 2,500 rpm	5 – 35 %

Mass Air Flow Sensor

INFOID:000000005152130

Supply voltage	Battery voltage (11 – 14 V)
Output voltage at idle	0.7 – 1.2 V*
Mass air flow (Using CONSULT-III or GST)	2.0 – 6.0 g-m/sec at idle* 7.0 – 20.0 g-m/sec at 2,500 rpm*

*: Engine is warmed up to normal operating temperature and running under no load.